



ZÜMO™ 500/550 INSTALLATION SHEET



WARNING: The terms of the Garmin warranty require that the power cable with bare wire leads be installed by experienced installers having the proper knowledge of automotive electrical systems and skill in the use of special tools or hardware required for installation.

1: Connect Power to the Mount

Select a suitable and secure location to mount the zümo on your motorcycle based on available power sources and safe cable routing.



About connecting audio

Standard jacks for microphone (2.5 mm) and audio out (3.5 mm) are located on the left side of the mount (under a weather cap). When connecting your audio system to the zümo, be sure to consider the pathways needed to route the necessary cables. For information about hands-free audio and phone options, refer to the zümo 500/550 *Quick Reference Guide* and the zümo 500/550 *Owner's Manual* on disk.

2: Install the Handlebar Base

The zümo includes parts for two handlebar installation solutions. Custom mounts can require additional hardware (www.ram-mount.com).

A) To install the U-bolt and handlebar base:

1. Place the U-bolt around the handlebar, and thread the ends through the handlebar base.
2. Tighten the nuts to secure the base. Do not overtighten.



NOTE: The recommended torque is 50in-lb. Do not exceed maximum torque of 80in-lb.

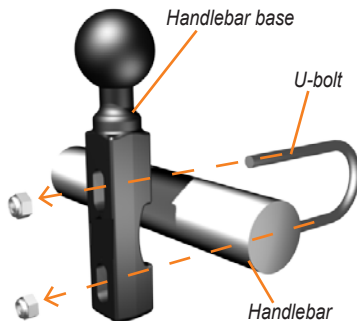

B) To install the handlebar base to the clutch/brake clamp bracket:



NOTE: Both 1/4" standard and M6 bolts are included. Match the size of the factory bolts on your clutch/brake clamp bracket.

1. Remove the two factory bolts on your clutch/brake clamp bracket.
2. Thread the new bolts through the handlebar base, spacers, and clamp bracket.
3. Tighten the bolts to secure the base.

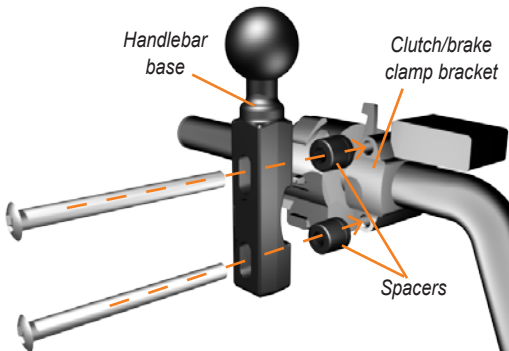

Garmin® is a trademark of Garmin Ltd. or its subsidiaries, registered in the USA and other countries. zümo™ is a trademark of Garmin Ltd. or its subsidiaries. These trademarks may not be used without the express permission of Garmin.

3: Attach the Base Plate to the zūmo Mount

1. Thread the M4 x 40 mm flathead bolts and nuts to attach the base plate to the zūmo mount.
2. Tighten the nuts to secure the base plate.

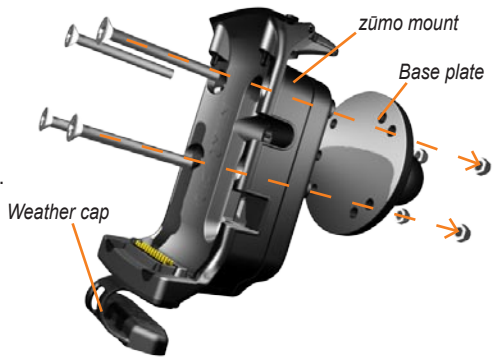

4: Attach the Base Plate to the Handlebar Base

1. Align the ball of the handlebar base and the ball of the base plate with the double-socket arm.
2. Tighten the knob slightly.
3. Adjust for better viewing and operation.
4. Tighten the knob to secure the mount.

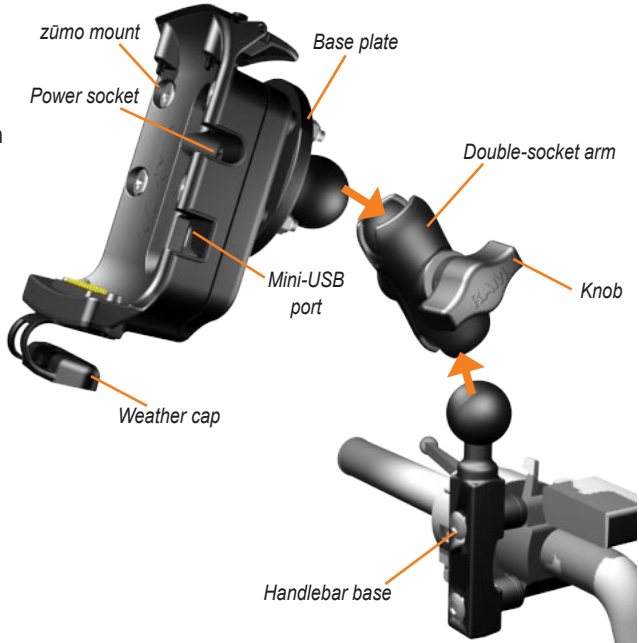

5: Install the zūmo in the Mount

1. Plug the power cable into the zūmo mount. For a better seal, tighten the screws on the power connector.
2. Flip the lever up.
3. Flip the weather cap down and under (magnetic).
4. Place the zūmo into the mount, and flip the lever down.
5. Tighten the security screw.



About the Security Screwdriver

Use the security screw to better secure the zūmo to the mount. You can connect the screwdriver to your key chain for easy access.



Security screwdriver

To remove the zūmo from the mount:

1. Loosen the security screw.
2. Flip up the lever on the mount.
3. Lift out the zūmo.

TIP: When your zūmo is not in the mount, use the weather cap to prevent damage to the connector.



More Information

For more information about the zūmo, refer to the zūmo 500/550 Owner's Manual on disk.

See the *Important Safety and Product Information* guide in the product box for product warnings and legal information.