

G1000® Integrated Avionics System

Cockpit Reference Guide for the Diamond DA62



GARMIN

The Garmin logo consists of the word "GARMIN" in a bold, white, sans-serif font, with a white triangle pointing upwards to the right of the letter "N". The logo is set against a background of a dark, detailed aeronautical chart.

FLIGHT INSTRUMENTS

ENGINE INDICATION SYSTEM

NAV/COM/TRANSPONDER/AUDIO PANEL

AUTOMATIC FLIGHT CONTROL SYSTEM

GPS NAVIGATION

FLIGHT PLANNING

PROCEDURES

HAZARD AVOIDANCE

ADDITIONAL FEATURES

ABNORMAL OPERATION

ANNUNCIATIONS & ALERTS

APPENDIX

INDEX

Copyright © 2015, 2016 Garmin Ltd. or its subsidiaries. All rights reserved.

This manual reflects the operation of System Software version 1373.01 or later for the Diamond DA62. Some differences in operation may be observed when comparing the information in this manual to earlier or later software versions.

Garmin International, Inc., 1200 East 151st Street, Olathe, Kansas 66062, U.S.A.

Tel: 913.397.8200

Fax: 913.397.8282

Aircraft On Ground (AOG) Hotline: 913.397.0836

Aviation Dealer Technical Support: 888.606.5482

Garmin AT, Inc., 2345 Turner Road SE, Salem, OR 97302, U.S.A.

Tel: 503.391.3411

Fax 503.364.2138

Garmin (Europe) Ltd, Liberty House, Hounslow Business Park

Southampton, Hampshire SO40 9LR, U.K.

Tel: 44 (0) 238 052 4000

Fax: 44 (0) 238 052 4004

Aviation Support: +44 (0) 370 850 1243

Garmin Corporation, No. 68, Zhangshu 2nd Road, Xizhi District, New Taipei City Taiwan

Tel: 34-93-357-2608

Fax: 34-93-429-4484

Web Site Address: www.garmin.com

Except as expressly provided herein, no part of this manual may be reproduced, copied, transmitted, disseminated, downloaded or stored in any storage medium, for any purpose without the express written permission of Garmin. Garmin hereby grants permission to download a single copy of this manual and of any revision to this manual onto a hard drive or other electronic storage medium to be viewed for personal use, provided that such electronic or printed copy of this manual or revision must contain the complete text of this copyright notice and provided further that any unauthorized commercial distribution of this manual or any revision hereto is strictly prohibited.

Garmin®, G1000®, WATCH®, FliteCharts®, and SafeTaxi® are registered trademarks of Garmin International, Inc. or its subsidiaries. Garmin ESP™, Garmin SVT™, and Connex™ are trademarks of Garmin International, Inc. or its subsidiaries. These trademarks may not be used without the express permission of Garmin.

Skywatch® and Stormscope® are registered trademarks of L-3 Communications. Ryan®, TCAD® and Avidyne® are registered trademarks of Avidyne Corporation. CO Guardian is a trademark of CO Guardian, Inc. AC-U-KWIK® is a registered trademark of Penton Business Media Inc. Bendix/King® and Honeywell® are registered trademarks of Honeywell International, Inc. Becker® is a registered trademark of Becker Flugfunkwerk GmbH. NavData® is a registered trademark of Jeppesen, Inc.; Wi-Fi® is a registered trademark of the Wi-Fi Alliance. SiriusXM Weather and SiriusXM Satellite Radio are provided by SiriusXM Satellite Radio, Inc.

AOPA Membership Publications, Inc. and its related organizations (hereinafter collectively "AOPA") expressly disclaim all warranties, with respect to the AOPA information included in this data, express or implied, including, but not limited to, the implied warranties of merchantability and fitness for a particular purpose. The information is provided "as is" and AOPA does not warrant or make any representations regarding its accuracy, reliability, or otherwise. Under no circumstances including negligence, shall AOPA be liable for any incidental, special or consequential damages that result from the use or inability to use the software or related documentation, even if AOPA or an AOPA authorized representative has been advised of the possibility of such damages. User agrees not to sue AOPA and, to the maximum extent allowed by law, to release and hold harmless AOPA from any causes of action, claims or losses related to any actual or alleged inaccuracies in the information. Some jurisdictions do not allow the limitation or exclusion of implied warranties or liability for incidental or consequential damages so the above limitations or exclusions may not apply to you.

AC-U-KWIK and its related organizations (hereafter collectively "AC-U-KWIK Organizations") expressly disclaim all warranties with respect to the AC-U-KWIK information included in this data, express or implied, including, but not limited to, the implied warranties of merchantability and fitness for a particular purpose. The information is provided "as is" and AC-U-KWIK Organizations do not warrant or make any representations regarding its accuracy, reliability, or otherwise. Licensee agrees not to sue AC-U-KWIK Organizations and, to the maximum extent allowed by law, to release and hold harmless AC-U-KWIK Organizations from any cause of action, claims or losses related to any actual or alleged inaccuracies in the information arising out of Garmin's use of the information in the datasets. Some jurisdictions do not allow the limitation or exclusion of implied warranties or liability for incidental or consequential damages so the above limitations or exclusions may not apply to licensee.

Printed in the U.S.A



WARNING: Do not use terrain avoidance displays as the sole source of information for maintaining separation from terrain and obstacles. Garmin obtains terrain and obstacle data from third party sources and cannot independently verify the accuracy of the information.



WARNING: Always refer to current aeronautical charts and NOTAMs for verification of displayed aeronautical information. Displayed aeronautical data may not incorporate the latest NOTAM information.



WARNING: Do not use geometric altitude for compliance with air traffic control altitude requirements. The primary barometric altimeter must be used for compliance with all air traffic control altitude regulations, requirements, instructions, and clearances.



WARNING: Do not use basemap information (land and water data) as the sole means of navigation. Basemap data is intended only to supplement other approved navigation data sources and should be considered only an aid to enhance situational awareness.



WARNING: Do not rely solely upon the display of traffic information to accurately depict all of the traffic within range of the aircraft. Due to lack of equipment, poor signal reception, and/or inaccurate information from aircraft or ground stations, traffic may be present that is not represented on the display.



WARNING: Do not use data link weather information for maneuvering in, near, or around areas of hazardous weather. Information contained within data link weather products may not accurately depict current weather conditions.



WARNING: Do not use the indicated data link weather product age to determine the age of the weather information shown by the data link weather product. Due to time delays inherent in gathering and processing weather data for data link transmission, the weather information shown by the data link weather product may be older than the indicated weather product age.



WARNING: The displayed minimum safe altitude (MSAs) are only advisory in nature and should not be relied upon as the sole source of obstacle and terrain avoidance information. Always refer to current aeronautical charts for appropriate minimum clearance altitudes.



WARNING: Always obtain qualified instruction prior to operational use of this equipment.



WARNING: Do not use a QFE altimeter setting with this system. System functions will not operate properly with a QFE altimeter setting. Use only a QNH altimeter setting for height above mean sea level, or the standard pressure setting, as applicable.



WARNING: Do not use GPS to navigate to any active waypoint identified as a 'NON WGS84 WPT' by a system message. 'NON WGS84 WPT' waypoints are derived from an unknown map reference datum that may be incompatible with the map reference datum used by GPS (known as WGS84) and may be positioned in error as displayed.



WARNING: Because of variation in the earth's magnetic field, do not rely on the accuracy of attitude and heading indications (GRS 77 installations only) in the following geographic areas: North of 72° North latitude at all longitudes; South of 70° South latitude at all longitudes; North of 65° North latitude between longitude 75° W and 120° W. (Northern Canada); North of 70° North latitude between longitude 70° W and 128° W. (Northern Canada); North of 70° North latitude between longitude 85° E and 114° E. (Northern Russia); South of 55° South latitude between longitude 120° E and 165° E. (Region south of Australia and New Zealand).



WARNING: When using the autopilot to fly an approach with vertical guidance, the autopilot will not level the aircraft at the MDA/DH even if the MDA/DH is set in the altitude preselect.



WARNING: Do not rely solely upon the display of traffic information for collision avoidance maneuvering. The traffic display does not provide collision avoidance resolution advisories and does not under any circumstances or conditions relieve the pilot's responsibility to see and avoid other aircraft.



WARNING: Do not rely on information from a lightning detection system display as the sole basis for hazardous weather avoidance. Range limitations and interference may cause the system to display inaccurate or incomplete information. Refer to documentation from the lightning detection system manufacturer for detailed information about the system.



WARNING: Use appropriate primary systems for navigation, and for terrain, obstacle, and traffic avoidance. Garmin SVT is intended as an aid to situational awareness only and may not provide either the accuracy or reliability upon which to solely base decisions and/or plan maneuvers to avoid terrain, obstacles, or traffic.



WARNING: Intruder aircraft at or below 500 ft. AGL may not appear on the Garmin SVT display or may appear as a partial symbol.



WARNING: Do not use the Garmin SVT runway depiction as the sole means for determining the proximity of the aircraft to the runway or for maintaining the proper approach path angle during landing.



WARNING: Do not operate the weather radar in a transmitting mode when personnel or objects are within the MPEL boundary.



WARNING: Always position the weather radar gain setting to Calibrated for viewing the actual intensity of precipitation. Changing the gain in weather mode causes precipitation intensity to be displayed as a color not representative of the true intensity.



CAUTION: Do not clean display surfaces with abrasive cloths or cleaners containing ammonia. They will harm the anti-reflective coating.



CAUTION: Repairs should only be made by an authorized Garmin service center. Unauthorized repairs or modifications could void both the warranty and affect the airworthiness of the aircraft.



NOTE: Lamp(s) inside this product contain mercury (HG) and must be recycled or disposed of according to local, state, or federal laws. For more information, refer to our website at www.garmin.com/aboutGarmin/environment/disposal.jsp



NOTE: Do not rely solely upon data link services to provide Temporary Flight Restriction (TFR) information. Always confirm TFR information through official sources such as Flight Service Stations or Air Traffic Control.



NOTE: All visual depictions contained within this document, including screen images of the system panel and displays, are subject to change and may not reflect the most current system and aviation databases. Depictions of equipment may differ slightly from the actual equipment.



NOTE: The United States government operates the Global Positioning System and is solely responsible for its accuracy and maintenance. The GPS system is subject to changes which could affect the accuracy and performance of all GPS equipment. Portions of the system utilize GPS as a precision electronic NAVigation AID (NAVAID). Therefore, as with all NAVAIDs, information presented by the system can be misused or misinterpreted and, therefore, become unsafe.



NOTE: This device complies with part 15 of the FCC Rules. Operation is subject to the following two conditions: (1) this device may not cause harmful interference, and (2) this device must accept any interference received, including interference that may cause undesired operation.



NOTE: Interference from GPS repeaters operating inside nearby hangars can cause an intermittent loss of attitude and heading displays while the aircraft is on the ground. Moving the aircraft more than 100 yards away from the source of the interference should alleviate the condition.



NOTE: Use of polarized eyewear may cause the flight displays to appear dim or blank.



NOTE: This product, its packaging, and its components contain chemicals known to the State of California to cause cancer, birth defects, or reproductive harm. This notice is being provided in accordance with California's Proposition 65. If you have any questions or would like additional information, please refer to our web site at www.garmin.com/prop65.



NOTE: Operating the system in the vicinity of metal buildings, metal structures, or electromagnetic fields can cause sensor differences that may result in nuisance miscompare annunciations during start up, shut down, or while taxiing. If one or more of the sensed values are unavailable, the annunciation indicates no comparison is possible.



NOTE: The system responds to a terminal procedure based on data coded within that procedure in the Navigation Database. Differences in system operation may be observed among similar types of procedures due to differences in the Navigation Database coding specific to each procedure.



NOTE: The FAA has asked Garmin to remind pilots who fly with Garmin database-dependent avionics of the following:

- It is the pilot's responsibility to remain familiar with all FAA regulatory and advisory guidance and information related to the use of databases in the National Airspace System.
 - Garmin equipment will only recognize and use databases that are obtained from Garmin or Jeppesen. Databases obtained from Garmin or Jeppesen are assured compliance with all data quality requirements (DQRs) by virtue of a Type 2 Letter of Authorization (LOA) from the FAA. A copy of the Type 2 LOA is available for each database and can be viewed at <http://fly.garmin.com> by selecting 'Type 2 LOA Status.'
 - Use of a current Garmin or Jeppesen database in your Garmin equipment is required for compliance with established FAA regulatory guidance, but does not constitute authorization to fly any and all terminal procedures that may be presented by the system. It is the pilot's responsibility to operate in accordance with established AFM(S) and regulatory guidance or limitations as applicable to the pilot, the aircraft, and installed equipment.
-



NOTE: The pilot/operator must review and be familiar with Garmin's database exclusion list as discussed in SAIB CE-14-04 to determine what data may be incomplete. The database exclusion list can be viewed at www.flygarmin.com by selecting 'Database Exclusions List.'



NOTE: The pilot/operator must have access to Garmin and Jeppesen database alerts and consider their impact on the intended aircraft operation. The database alerts can be viewed at www.flygarmin.com by selecting 'Aviation Database Alerts.'



NOTE: If the pilot/operator wants or needs to adjust the database, contact Garmin Product Support.



NOTE: Garmin requests the flight crew report any observed discrepancies related to database information. These discrepancies could come in the form of an incorrect procedure; incorrectly identified terrain, obstacles and fixes; or any other displayed item used for navigation or communication in the air or on the ground. Go to FlyGarmin.com and select 'Aviation Data Error Report'.



NOTE: When using Stormscope, there are several atmospheric phenomena in addition to nearby thunderstorms that can cause isolated discharge points in the strike display mode. However, clusters of two or more discharge points in the strike display mode do indicate thunderstorm activity if these points reappear after the screen has been cleared.



NOTE: The system supports approval of AC 120-76C Hardware Class 3, Software Type B Electronic Flight Bag (EFB) electronic aeronautical chart applications. Possible additional requirements may make a secondary source (traditional paper or additional electronic display) necessary onboard the aircraft. If the secondary source is a Portable Electronic Device (PED), its use must be consistent with guidance in AC 120-76C.



NOTE: Operate G1000 system power through at least one cycle in a period of four days of continuous operation to avoid an autonomous system reboot.



NOTE: *The purpose of this Cockpit Reference Guide is to provide the pilot a resource with which to find operating instructions on the major features of the system more easily. It is not intended to be a comprehensive operating guide. Complete operating procedures for the system are found in the Pilot's Guide for this aircraft.*

Blank Page

Part Number	Change Summary
190-01896-00	Initial release at GDU 14.04
190-01896-01	Production release at GDU 15.12 Added ADS-B Traffic and Weather Updated Weather Radar Information Updated Sirius XM information Updated Connex information Added Bluetooth Management for Flight Stream 210 Updated CAS Messages Updated Weather and Traffic Messages Updated System Messages Updated Softkey Maps

Revision	Date of Revision	Affected Pages	Description
A	September, 2016	All	Production release

Blank Page

- Flight Instruments** 1
 - Selecting the Altimeter Barometric Pressure Setting 1
 - Selecting Standard Barometric Pressure (29.92 in Hg) 1
 - Change Altimeter Barometric Pressure Setting Units 1
 - Change Navigation Sources 1
 - Enable/Disable OBS Mode While Navigating with GPS 2
 - Generic Timer 2
 - Configure Vspeed Bugs 2
 - Set Barometric/Radar Altimeter Minimum Descent Altitude 3
 - Displaying Wind Data 3
 - Changing HSI Format 3
 - Displaying the DME Information Window 3
 - Selecting bearing display and changing sources 4

- Engine Indication System** 5
 - Engine Display 5
 - System Display 6
 - Fuel Display 6

- Nav/Com/Transponder/Audio Panel** 9
 - Enter or Change Flight ID 9
 - ADF Tuning (Optional) 9
 - DME Tuning (Optional) 9
 - Enter a Transponder Code 10
 - Selecting a COM Radio 10
 - Selecting a NAV Radio 10
 - NAV/COM Tuning 10
 - Digital Clearance Recorder and Player 11
 - Intercom System (ICS) Isolation 11

- Garmin Automatic Flight Control System** 13
 - Flight Director Activation 13
 - Vertical Modes 14
 - Lateral Modes 15
 - Underspeed Protection 15

- GPS Navigation** 17
 - Direct-to Navigation 17
 - Activate a Stored Flight Plan 18
 - Activate a Flight Plan Leg 18
 - Stop Navigating a Flight Plan 19

Vertical Navigation (VNV)	19
Flight Planning	21
Trip Planning	21
Create a User Waypoint Defined by Latitude & Longitude	23
Create a User Waypoint Defined by Radials from Other Waypoints	23
Create a User Waypoint Defined by a Radial & Distance from Another Waypoint	25
Delete a User Waypoint	27
Create a Flight Plan	27
Import a Flight Plan from an SD Card	28
Insert a Waypoint in the Active Flight Plan	29
Enter an Airway in a Flight Plan	30
User-Defined Holding Patterns	30
Invert an Active Flight Plan	32
Remove a Departure, Arrival, Approach, or Airway from a Flight Plan	33
Store a Flight Plan	33
Edit a Stored Flight Plan	33
Delete a Waypoint from the Flight Plan	34
Invert and Activate a Stored Flight Plan	34
Copy a Flight Plan	34
Delete a Flight Plan	35
Graphical Flight Plan Creation	35
Export a Flight Plan to an SD Card	36
Procedures	37
Load and Activate a Departure Procedure	37
Activate a Departure Leg	37
Load an Arrival Procedure	37
Activate an Arrival Leg	38
Load and/or Activate an Approach Procedure	38
Activate an Approach in the Active Flight Plan	40
Activate a Vector to Final Approach Fix	40
Activate a Missed Approach in the Active Flight Plan	40
Temperature Compensated Altitude	40
Hazard Avoidance	43
Customizing the Hazard Displays on the Navigation Map	43
Onboard Lightning Detection System (Optional)	43
SiriusXM Weather (Optional)	45
Garmin Connex Weather (Optional)	47
FIS-B Weather	59
Airborne Color Weather Radar	66

Traffic Systems	70
GDL 88 ADS-B Traffic (Optional)	72
Terrain and Obstacle Proximity	76
Terrain-SVS	76
Additional Features	79
Synthetic Vision (Optional)	79
Terminal Procedure Charts	80
Airport Directory	82
SiriusXM Satellite Radio Entertainment (Optional)	82
Satellite Telephone & SMS Messaging Service (Optional)	84
Electronic Stability and Protection (Garmin ESP™) (Optional)	96
Auxiliary Video (Optional)	97
Electronic Checklists (Optional)	99
Bluetooth® Management	101
Abnormal Operation	103
Reversionary Mode	103
Abnormal COM Operation	103
Hazard Displays with Loss of GPS Position	103
Unusual Attitudes	104
Dead Reckoning	104
Annunciations & Alerts	107
Warning Alerts	107
Caution Alerts	108
Annunciation Advisory	109
Message Advisory Alerts	109
AFCS Alerts	109
Terrain-SVS Alerts	110
SVS Terrain Status Annunciations	111
Voice Alerts	112
TIS Alerts and Annunciations	112
TAS Alerts and Annunciations	114
ADS-B Alerts and Annunciations	115
Weather Radar Alerts and Annunciations	117
GDL 69A SXM Data Link Receiver Messages	118
ADS-B Status Page messages	119
G1000 System Message Advisories	120
Flight Plan Import/Export Messages	138

Appendix..... 141

PFD Softkey Map 141

MFD Softkey Map 146

Loading Updated Databases 148

Index..... Index-1

FLIGHT INSTRUMENTS

SELECTING THE ALTIMETER BAROMETRIC PRESSURE SETTING

Turn the **BARO** Knob to select the desired setting.

SELECTING STANDARD BAROMETRIC PRESSURE (29.92 IN HG)

- 1) Press the **PFD** Softkey.
- 2) Press the **STD BARO** Softkey to set standard barometric pressure.

CHANGE ALTIMETER BAROMETRIC PRESSURE SETTING UNITS

- 1) Press the **PFD** Softkey to display the second-level softkeys.
- 2) Press the **ALT UNIT** Softkey.
- 3) Press the **IN** Softkey to display the barometric pressure setting in inches of mercury (in Hg).

Or:

Press the **HPA** Softkey to display the barometric pressure setting in hectopascals.

- 4) Press the **BACK** Softkey to return to the top-level softkeys.

CHANGE NAVIGATION SOURCES

- 1) Press the **CDI** Softkey to change from GPS to VOR1 or LOC1. This places the light blue tuning box over the NAV1 standby frequency in the upper left corner of the PFD.
- 2) Press the **CDI** Softkey again to change from VOR1 or LOC1 to VOR2 or LOC2. This places the light blue tuning box over the NAV2 standby frequency.
- 3) Press the **CDI** Softkey a third time to return to GPS.

ENABLE/DISABLE OBS MODE WHILE NAVIGATING WITH GPS

- 1) Press the **OBS** Softkey to select OBS Mode.
- 2) Turn a **CRS** Knob to select the desired course to/from the waypoint. Press a **CRS** Knob to synchronize the Selected Course with the bearing to the next waypoint.
- 3) Press the **OBS** Softkey again to return to automatic waypoint sequencing.

GENERIC TIMER

- 1) Press the **TMR/REF** Softkey, then turn the large **FMS** Knob to select the time field (hh/mm/ss). Turn the **FMS** Knobs to set the desired time, then press the **ENT** Key. The UP/DOWN field is now highlighted.
- 2) Turn the small **FMS** Knob to display the UP/DOWN window. Turn the **FMS** Knob to select 'UP' or 'DOWN', then press the **ENT** Key. 'START?' is now highlighted.
- 3) Press the **ENT** Key to START, STOP, or RESET the timer (if the timer is counting DOWN, it starts counting UP after reaching zero). Press the **CLR** Key or the **TMR/REF** Softkey to remove the window.

CONFIGURE VSPEED BUGS

- 1) Press the **TMR/REF** Softkey.
- 2) Turn the large **FMS** Knob to highlight the desired Vspeed.
- 3) Use the **FMS** Knob to enter the desired value. When a speed has been changed from a default value, an asterisk appears next to the speed.
- 4) Press the **ENT** Key or turn the large **FMS** Knob to highlight the ON/OFF field.
- 5) Turn the small **FMS** Knob clockwise to ON or counterclockwise to OFF.
- 6) To remove the window, press the **CLR** Key or the **TMR/REF** Softkey.

SET BAROMETRIC/RADAR ALTIMETER MINIMUM DESCENT ALTITUDE

- 1) Press the **TMR/REF** Softkey.
- 2) Turn the large **FMS** Knob to highlight the OFF/BARO/TEMP COMP/RAD ALT field to the right of 'MINIMUMS'.
- 3) Turn the small **FMS** Knob clockwise to select BARO or RAD ALT.
- 4) Press the **ENT** Key.
- 5) Use the small **FMS** Knob to enter the desired altitude.
- 6) Press the **ENT** Key.
- 7) To remove the window, press the **CLR** Key or the **TMR/REF** Softkey.

DISPLAYING WIND DATA

- 1) Press the **PFD** Softkey.
- 2) Press the **WIND** Softkey to display wind data to the left of the HSI.
- 3) Press one of the **OPTN** softkeys to change how wind data is displayed.
- 4) To remove the Wind Data Window, press the **OFF** Softkey.

CHANGING HSI FORMAT

- 1) Press the **PFD** Softkey.
- 2) Press the **HSI FRMT** Softkey.
- 3) Press the **360 HSI** or **ARC HSI** Softkey.

DISPLAYING THE DME INFORMATION WINDOW

- 1) Press the **PFD** Softkey.
- 2) Press the **DME** Softkey to display the DME Information Window.
- 3) To remove the DME Information Window, press the **DME** Softkey again.

SELECTING BEARING DISPLAY AND CHANGING SOURCES

- 1) Press the **PFD** Softkey.
- 2) Press either the **BRG1** Softkey or **BRG2** Softkey to display the desired bearing pointer and information window with a NAV source.
- 3) Press the **BRG1** Softkey or **BRG2** Softkey again to change the bearing source to GPS.
- 4) Press the **BRG1** Softkey or **BRG2** Softkey again to change the bearing source to ADF.
- 5) To remove the bearing pointer and information window, press the **BRG** Softkey again.

ENGINE INDICATION SYSTEM



NOTE: Refer to the Airplane Flight Manual (AFM) for applicable RPM indications.

ENGINE DISPLAY

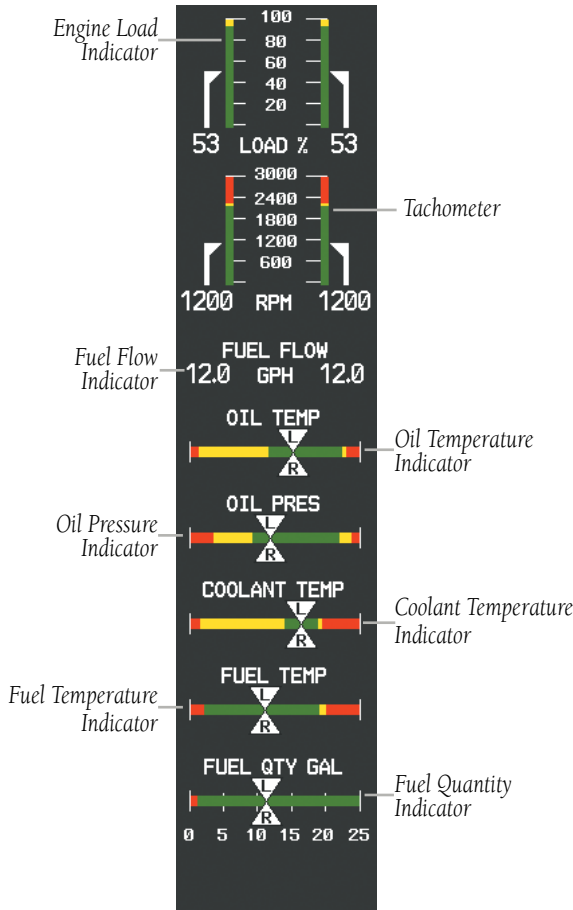

Engine Display

SYSTEM DISPLAY

Pressing the **ENGINE** Softkey displays the **SYSTEM** and **FUEL** softkeys. Press the **SYSTEM** Softkey to show the System Display.

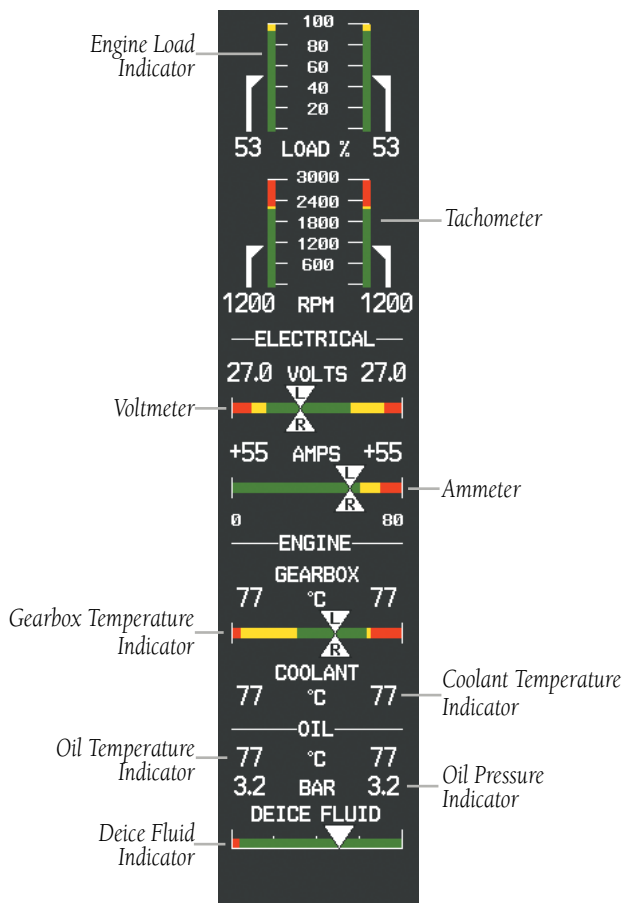

System Display

FUEL DISPLAY

Pressing the **ENGINE** Softkey displays the **SYSTEM** and **FUEL** softkeys. Press the **FUEL** Softkey to show the Fuel Display.

Fuel used (GAL USED), endurance (ENDUR), and fuel range (RANGE NM) are all calculated based on the last manual adjustment of the fuel remaining (GAL REM).

Measured fuel quantity has no effect on fuel calculations. Fuel calculations are based on sensed fuel flow and the last manual adjustment of the fuel remaining.

- **DEC FUEL** – Allows the pilot to decrease the gallons of fuel remaining (GAL REM) in 1-gallon increments
- **INC FUEL** – Allows the pilot to increase the gallons of fuel remaining in 1-gallon increments
- **RST FUEL** – Resets the fuel remaining to 50.0 gallons with standard fuel tanks or 86 gallons with auxiliary fuel tanks. Reset gallons used to zero.

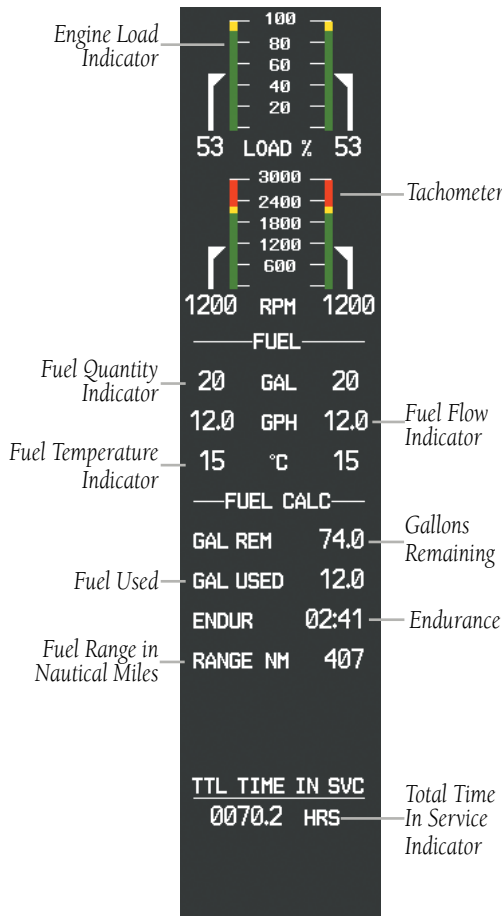

Fuel Display

Adjusting the fuel totalizer quantity:

From the Fuel Display, press the **DEC FUEL** or **INC FUEL** Softkey to obtain the desired number of gallons remaining (GAL REM).

Resetting the fuel totalizer:

From the Fuel Display, press the **RST FUEL** Softkey. This resets the displayed fuel remaining (GAL REM) to 50 gallons (or 86 gallons if optional aux fuel tanks are installed). The fuel used (GAL USED) is reset to zero.

- Flight Instruments
- EIS
- Nav/Com/XPDR/Audio
- AFC
- GPS Nav
- Flight Planning
- Procedures
- Hazard Avoidance
- Additional Features
- Abnormal Operation
- Annun/Alerts
- Appendix
- Index

NAV/COM/TRANSPONDER/AUDIO PANEL

ENTER OR CHANGE FLIGHT ID

- 1) Press the **TMR/REF** Softkey, then turn the large **FMS** Knob to highlight the Flight ID field.
- 2) Turn the small **FMS** Knob to enter the first character.
- 3) Turn the large **FMS** Knob to select the next field.
- 4) Turn the small **FMS** Knob to enter the next desired character.
- 5) Repeat steps 3 and 4 until the desired Flight ID is entered.
- 6) Press the **ENT** Key to update the Flight ID.

ADF TUNING (OPTIONAL)

- 1) Press the **ADF/DME** Softkey.
- 2) Turn the small **FMS** Knob to enter the first digit of the desired ADF frequency.
- 3) Turn the large **FMS** Knob to select the next desired field.
- 4) Turn the small **FMS** Knob to enter the desired number.
- 5) Repeat steps 3 and 4 until the desired ADF frequency is entered.
- 6) Press the **ENT** Key to accept the new frequency.
- 7) Press the **ENT** Key again to transfer the frequency to the active field.
- 8) Turn the large **FMS** Knob to select the MODE field.
- 9) Turn the small **FMS** Knob to select ANT, ADF, ADF/BFO, or ANT/BFO.
- 10) Press the **ENT** Key to complete the selection.

DME TUNING (OPTIONAL)

- 1) Press the **ADF/DME** or **DME** Softkey.
- 2) Turn the large **FMS** to select the DME source field.
- 3) Turn the small **FMS** Knob to select the desired Nav radio.
- 4) Press the **ENT** Key to complete the selection.

ENTER A TRANSPONDER CODE

- 1) Press the **XPDR** Softkey to display the transponder mode selection softkeys.
- 2) Press the **CODE** Softkey to display the transponder code selection softkeys, for digit entry.
- 3) Press the digit softkeys to enter the code in the code field. When entering the code, the next key in sequence must be pressed within 10 seconds, or the entry is cancelled and restored to the previous code. Five seconds after the fourth digit has been entered, the transponder code becomes active.

SELECTING A COM RADIO

Transmit/Receive

Press the **COM1 MIC**, **COM2 MIC**, or **COM3 MIC** Key (optional COM, if installed) on the audio panel.

Receive Only

Press the **COM1**, **COM2**, or **COM3** Key (optional COM, if installed) on the audio panel.

SELECTING A NAV RADIO

- 1) To begin navigating using a navigation radio, press the **CDI** Softkey on the PFD to select VOR1/LOC1 (NAV1) or VOR2/LOC2 (NAV2).
- 2) Press the **NAV1**, **NAV2**, **DME**, or **ADF** Key on the audio panel to select or deselect the navigation radio audio source. All radio keys can be selected individually or together.

NAV/COM TUNING

- 1) Press the small tuning knob to select the desired radio for tuning. A light blue box highlights the radio frequency to be tuned.
- 2) Turn the respective tuning knobs to enter the desired frequency into the standby frequency field. The large knob enters MHz and the small knob enters kHz.
- 3) Press the **Frequency Transfer** Key to place the frequency into the active frequency field.

DIGITAL CLEARANCE RECORDER AND PLAYER



NOTE: Only the audio for the selected **COM MIC** Key is recorded. Audio is not recorded for COM3 MIC.

- Pressing the **PLAY** Key once plays the latest recorded memory block, then returns to normal operation.
- Pressing the **MKR/MUTE** Key while playing a memory block stops play.
- Pressing the **PLAY** Key during play begins playing the previously recorded memory block. Each subsequent press of the **PLAY** Key begins playing the next previously recorded block.

INTERCOM SYSTEM (ICS) ISOLATION

Press the **PILOT** and/or **COPLT** Key to select those isolated from hearing the Nav/Com radios and music.

Mode	PILOT KEY ANNUNCIATOR	COPLT KEY ANNUNCIATOR	Pilot Hears	Copilot Hears	Passenger Hears
ALL	OFF	OFF	Selected radios; pilot; copilot; passengers; music	Selected radios; pilot; copilot; passengers; music	Selected radios; pilot; copilot; passengers; music
PILOT	ON	OFF	Selected radios; pilot	Copilot; passengers; music	Copilot; passengers; music
COPILOT	OFF	ON	Selected radios; pilot; passengers; music	Copilot	Selected radios; pilot; passengers; music
CREW	ON	ON	Selected radios; pilot; copilot	Selected radios; pilot; copilot	Passengers; music

- Flight Instruments
- EIS
- Nav/Com/XPDR/Audio**
- AFCs
- GPS Nav
- Flight Planning
- Procedures
- Hazard Avoidance
- Additional Features
- Abnormal Operation
- Annun/Alerts
- Appendix
- Index

Blank Page

GARMIN AUTOMATIC FLIGHT CONTROL SYSTEM



NOTE: If sensor information (other than attitude) required for a flight director mode becomes invalid or unavailable, the flight director automatically reverts to the default mode for that axis.



NOTE: If the attitude information required for the default flight director modes becomes invalid or unavailable, the autopilot automatically disengages.

FLIGHT DIRECTOR ACTIVATION

An initial press of a key listed in the following table (when the flight director is not active) activates the pilot-side flight director in the listed modes.

Control Pressed	Modes Selected			
	Lateral		Vertical	
FD Key	Roll Hold (default)	ROL	Pitch Hold (default)	PIT
AP Key	Roll Hold (default)	ROL	Pitch Hold (default)	PIT
CWS Button	Roll Hold (default)	ROL	Pitch Hold (default)	PIT
GO-AROUND Button	Takeoff (on ground)	TO	Takeoff (on ground)	TO
	Go Around (in air)	GA	Go Around (in air)	GA
ALT Key	Roll Hold (default)	ROL	Altitude Hold	ALT
VS Key	Roll Hold (default)	ROL	Vertical Speed	VS
VNV Key	Roll Hold (default)	ROL	Vertical Path Tracking*	VPTH
NAV Key	Navigation**	GPS	Pitch Hold (default)	PIT
		VOR		
		LOC		
		BC		
APR Key	Approach**	GPS	PIT	
		VOR	GP	
		LOC	GS	
HDG Key	Heading Select	HDG	Pitch Hold (default)	PIT

*Valid VNV flight plan must be entered before **VNV** Key press activates flight director.

The selected navigation receiver must have a valid VOR or LOC signal or active GPS course before **NAV or **APR** Key press activates flight director.

VERTICAL MODES

Vertical Mode	Description	Control	Annunciation	
Pitch Hold	Holds aircraft pitch attitude; may be used to climb/descend to the Selected Altitude	(default)	PIT	
Selected Altitude Capture	Captures the Selected Altitude	*	ALTS	
Altitude Hold	Holds current Altitude Reference	ALT Key	ALT	nnnnnFT
Vertical Speed	Holds aircraft vertical speed; may be used to climb/descend to the Selected Altitude	VS Key	VS	nnnnnFPM
Flight Level Change	Maintains the current aircraft airspeed while the aircraft is climbing/descending to the Selected Altitude	FLC Key	FLC	nnnKT
Vertical Path Tracking	Captures and tracks descent legs of an active vertical profile	VNV Key	VPTH	
VNV Target Altitude Capture	Captures the Vertical Navigation (VNV) Target Altitude	**	ALTV	
Glidepath***	Captures and tracks the SBAS glidepath on approach	APR Key	GP	
Glideslope	Captures and tracks the ILS glideslope on approach		GS	
Takeoff	Commands a constant pitch angle and wings level on the ground in preparation for takeoff	GO-AROUND Button	TO	
Go Around	Commands a constant pitch angle and wings level		GA	

* ALTS is armed automatically when PIT, VS, FLC, or GA is active, and under VPTH when the Selected Altitude is to be captured instead of the VNV Target Altitude.

** ALTV is armed automatically under VPTH when the VNV Target Altitude is to be captured instead of the Selected Altitude.

***GP is available in installations with GIA 63W IAUs when SBAS is available.

LATERAL MODES

Lateral Mode	Description	Control	Annunciation
Roll Hold	Holds the current aircraft roll attitude or rolls the wings level, depending on the commanded bank angle	(default)	ROL
Heading Select	Captures and tracks the Selected Heading	HDG Key	HDG
Navigation, GPS	Captures and tracks the selected navigation source (GPS, VOR, LOC)	NAV Key	GPS
Navigation, VOR Enroute Capture/Track			VOR
Navigation, LOC Capture/Track (No Glideslope)			LOC
Navigation, Backcourse Capture/Track	Captures and tracks a localizer signal for backcourse approaches		BC
Approach, GPS	Captures and tracks the selected navigation source (GPS, VOR, LOC)	APR Key	GPS
Approach, VOR Capture/Track			VAPP
Approach, LOC (Glideslope Mode automatically armed)			LOC
Go Around	Commands a constant pitch angle and wings level	GO-AROUND Button	GA
<i>The Garmin AFCS limits turn rate to 3 degrees per second (standard rate turn).</i>			

UNDERSPEED PROTECTION

Underspeed Protection is available when the optional Electronic Stability and Protection (Garmin ESP) system is installed and the autopilot is on.

When the aircraft airspeed reaches between 90-95 kts, a flashing yellow ‘MINSPD’ annunciation will appear above the airspeed indicator. When the airspeed trend vector reaches a predetermined airspeed (specific to each flap setting), a single aural “AIRSPEED” will sound, alerting the pilot to the impending underspeed condition.

- Flaps UP 85 kts
- Flaps T/O 82 kts
- Flaps LDG 78 kts

If the aircraft continues to decelerate, Underspeed Protection becomes active. Vertical flight director modes can be divided into two categories: Those in which it is important to maintain altitude for as long as possible (altitude-critical modes), and those in which maintaining altitude is less crucial (non-altitude critical modes).

Altitude-Critical Modes (ALT, GS, GP, TO, GA, FLC)

When the aircraft decelerates to stall warning, the lateral and vertical flight director modes will change from active to armed, and the autopilot will provide input causing the aircraft to pitch down and the wings to level.

An aural “AIRSPEED” alert will sound every five seconds and a red “USP ACTIVE” annunciation will appear to the right of the Vertical Speed Indicator (see Annunciations & Alerts). The pitch down force will continue until the aircraft reaches a pitch attitude at which IAS equals the IAS at which stall warning turns off, plus two knots.

When airspeed increases (as a result of adding power/thrust) to above the IAS at which stall warning turns off, plus two knots, the autopilot will cause the aircraft to pitch up until recapturing the vertical reference and the vertical and lateral flight director modes will change from armed to active.

Non-Altitude Critical Modes (PIT, VS, VNAV, IAS)

When the aircraft decelerates to an IAS below the minimum commandable autopilot airspeed, a red “USP ACTIVE” annunciation will appear to the right of the Vertical Speed Indicator. The vertical flight director mode will change from active to armed, and the autopilot will cause the aircraft to pitch down until reaching a pitch attitude at which IAS equals the minimum commandable autopilot airspeed.

When airspeed increases (as a result of adding power/thrust) to an IAS above the minimum commandable autopilot airspeed, the autopilot will cause the aircraft to pitch up until recapturing the vertical reference and the vertical flight director mode will change from armed to active.

GPS NAVIGATION

DIRECT-TO NAVIGATION

Direct-to Navigation from the MFD

- 1) Press the **Direct-to** () Key.
- 2) Enter the waypoint identifier.
- 3) Press the **ENT** Key to confirm the identifier. The 'Activate?' field is highlighted.
- 4) If no altitude constraint or course is desired, press the **ENT** Key to activate. To enter an altitude constraint, proceed to step 5.
- 5) Turn the large **FMS** Knob to place the cursor over the 'VNV' altitude field.
- 6) Enter the desired altitude.
- 7) Press the **ENT** Key. If the waypoint entered is an airport, the option to select MSL or AGL is now displayed. If the waypoint is not an airport, proceed to step 9.
- 8) Turn the small **FMS** Knob to select 'MSL' or 'AGL'.
- 9) Press the **ENT** Key. The cursor is now flashing in the VNV offset distance field.
- 10) Enter the desired offset distance before (-) the waypoint.
- 11) Press the **ENT** Key. The 'Activate?' field is highlighted.
- 12) Press the **ENT** Key to activate.

Direct-to Navigation from the PFD

- 1) Press the **Direct-to** Key () .
- 2) Turn the large **FMS** Knob to place the cursor in the desired selection field.
- 3) Turn the small **FMS** Knob to begin selecting the desired identifier, location, etc.
- 4) Press the **ENT** Key.
- 5) The cursor is now flashing on 'ACTIVATE?'. If no altitude constraint or course is desired, press the **ENT** Key to activate. To enter an altitude constraint, proceed to step 6.
- 6) Turn the large **FMS** Knob to place the cursor over the 'ALT' altitude field.

- 7) Turn the small **FMS** Knob to enter the desired altitude.
- 8) Press the **ENT** Key. If the waypoint entered is an airport, the option to select MSL or AGL is now displayed. If the waypoint is not an airport, proceed to step 10.
- 9) Turn the small **FMS** Knob to select 'MSL' or 'AGL'.
- 10) Press the **ENT** Key. The cursor is placed in the 'OFFSET' field.
- 11) Turn the small **FMS** Knob to enter the desired target altitude offset from the selected Direct-to.
- 12) Press the **ENT** Key to highlight 'Activate?' or turn the large **FMS** Knob to highlight the 'CRS' field.
- 13) Turn the small **FMS** Knob to enter the desired course to the waypoint.
- 14) Press the **ENT** Key to highlight 'ACTIVATE?'.
- 15) Press the **ENT** again to activate the Direct-to.

ACTIVATE A STORED FLIGHT PLAN

- 1) Press the **FPL** Key on the MFD and turn the small **FMS** Knob to display the Flight Plan Catalog Page.
- 2) Press the **FMS** Knob to activate the cursor.
- 3) Turn the large **FMS** Knob to highlight the desired flight plan
- 4) Press the **ACTIVE** Softkey. The confirmation window is now displayed.
- 5) With 'OK' highlighted, press the **ENT** Key to activate the flight plan. To cancel the flight plan activation, turn the large **FMS** Knob to highlight 'CANCEL' and press the **ENT** Key.

ACTIVATE A FLIGHT PLAN LEG

- 1) From the Active Flight Plan Page, press the **FMS** Knob to activate the cursor and turn the large **FMS** Knob to highlight the desired waypoint.
- 2) On the MFD, press the **ACT LEG** Softkey.

OR

Press the **MENU** Key, select the 'Activate Leg' option from the page menu and press the **ENT** Key. This step must be used when activating a leg from the PFD.

- 3) With 'Activate' highlighted, press the **ENT** Key.

STOP NAVIGATING A FLIGHT PLAN

- 1) Press the **FPL** Key to display the Active Flight Plan Page.
- 2) Press the **MENU** Key to display the Page Menu Window.
- 3) Turn the large **FMS** Knob to highlight 'Delete Flight Plan' and press the **ENT** Key. With 'OK' highlighted, press the **ENT** Key to deactivate the flight plan. This does not delete the stored flight plan, only the active flight plan.

VERTICAL NAVIGATION (VNV)

The navigation database only contains altitudes for procedures that call for "Cross at" altitudes. If the procedure states "Expect to cross at," the altitude is not in the database. In this case the altitude may be entered manually.

ACTIVE FLIGHT PLAN			
KIXD / KDFW			
	DTK	DIS	ALT
KARLA	221°	11.7NM	13000FT
COVIE	221°	9.0NM	12400FT
LEMYN	220°	8.0NM	9900FT
Approach - KDFW-RNAV 17L GPs LPV			
RIVET iaf	259°	18.8NM	4000FT
DRAAK	176°	3.3NM	2000FT
INWOD	176°	3.2NM	3000FT
MENOL faf	176°	3.9NM	2300FT
RW17L map	176°	5.3NM	
990FT	174°	0.8NM	990FT
POLKE			

5000FT

Cross AT or ABOVE 5,000 ft

2300FT

Cross AT 2,300 ft

3000FT

Cross AT or BELOW 3,000 ft

Altitudes associated with approach procedures are “auto-designated”. This means the system automatically uses the altitudes loaded with the approach for giving vertical flight path guidance outside the FAF. Note these altitudes are displayed as small light blue text.

Altitudes associated with arrival procedures are “manually-designated”. This means the system does not use the altitudes loaded with the arrival for giving vertical flight path guidance until designated to do so by the pilot. Note that these altitudes are initially displayed as white text. These altitudes may be “designated” by placing the cursor over the desired altitude and pressing the **ENT** Key. After designation, the text changes to light blue.

Altitudes that have been designated for use in vertical navigation may also be made “non-designated” by placing the cursor over the desired altitude and pressing the **CLR** Key. The altitude is now displayed only as a reference. It will not be used to give vertical flight path guidance. Other displayed altitudes may change due to re-calculations or rendered invalid as a result of manually changing an altitude to a non-designated altitude.

	White Text	Light Blue Text	Light Blue Subdued Text
Large Text	Altitude calculated by the system estimating the altitude of the aircraft as it passes over the navigation point. This altitude is provided as a reference and is not designated to be used in determining vertical flight path guidance.	Altitude has been entered by the pilot. Altitude is designated for use in giving vertical flight path guidance. Altitude does not match the published altitude in navigation database or no published altitude exists.	The system cannot use this altitude in determining vertical flight path guidance.
Small Text	Altitude is not designated to be used in determining vertical flight path guidance. Altitude has been retrieved from the navigation database and is provided as a reference.	Altitude is designated for use in giving vertical flight path guidance. Altitude has been retrieved from the navigation database or has been entered by the pilot and matches a published altitude in the navigation database.	The system cannot use this altitude in determining vertical flight path guidance.

FLIGHT PLANNING

TRIP PLANNING

- 1) Turn the large **FMS** Knob to select the 'AUX' page group.
- 2) Turn the small **FMS** Knob to select the first rectangular page icon.
- 3) The current 'PAGE MODE' is displayed at the top of the page: 'AUTOMATIC' or 'MANUAL'. To change the page mode, press the **AUTO** or **MANUAL** Softkey.
- 4) For Direct-to planning:
 - a) Press the **WPTS** Softkey and verify that the starting waypoint field indicates 'P.POS' (present position).
 - b) If necessary, press the **MENU** Key and select 'Set WPT to Present Position' to display 'P.POS'.
 - c) Press the **ENT** Key and the flashing cursor moves to the ending waypoint field.
 - d) Enter the identifier of the ending waypoint and press the **ENT** Key to accept the waypoint.

Or:

For point-to-point planning:

- a) Enter the identifier of the starting waypoint.
- b) Once the waypoint's identifier is entered, press the **ENT** Key to accept the waypoint. The flashing cursor moves to the ending waypoint.
- c) Again, enter the identifier of the ending waypoint.
- d) Press the **ENT** Key to accept the waypoint.

Or:

For flight plan leg planning:

- a) Press the **FPL** Softkey (at the bottom of the display).
- b) Turn the small **FMS** Knob to select the desired flight plan (already stored in memory), by number.
- c) Turn the large **FMS** Knob to highlight the 'LEG' field.

- d) Turn the small **FMS** Knob to select the desired leg of the flight plan, or select 'CUM' to apply trip planning calculations to the entire flight plan. Selecting 'FPL 00' displays the active flight plan. If an active flight plan is selected, 'REM' is an available option to display planning data for the remainder of the flight plan.



NOTE: The page mode must be set to 'MANUAL' to perform the following steps.

- 5) Turn the large **FMS** Knob to highlight the departure time (DEP TIME) field.



NOTE: The departure time on the Trip Planning Page is used for preflight planning. Refer to the Utility Page for the actual flight departure time.

- 6) Enter the departure time. Press the **ENT** Key when finished. Departure time may be entered in local or UTC time, depending upon system settings.
- 7) The flashing cursor moves to the ground speed (GS) field. Enter the ground speed. Press the **ENT** Key when finished. Note that in 'automatic' page mode, ground speed is provided by the system.
- 8) The flashing cursor moves to the fuel flow field. Enter the fuel flow. Press the **ENT** Key when finished. Note that in 'AUTOMATIC' page mode, fuel flow is provided by the system.
- 9) The flashing cursor moves to the fuel onboard field. Enter the fuel onboard. Press the **ENT** Key when finished. Note that in 'AUTOMATIC' page mode, fuel onboard is provided by the fuel totalizer.
- 10) The flashing cursor moves to the calibrated airspeed (CALIBRATED AS) field. Enter the calibrated airspeed. Press the **ENT** Key when finished. Note that in 'AUTOMATIC' page mode, calibrated airspeed is provided by the system.
- 11) The flashing cursor moves to the altitude (IND ALTITUDE) field. Enter the altitude. Press the **ENT** Key when finished. Note that in 'AUTOMATIC' page mode, altitude is provided by the system.
- 12) The flashing cursor moves to the barometric setting (PRESSURE) field. Enter the desired baro setting. Press the **ENT** Key when finished. Note that in 'AUTOMATIC' page mode, the baro setting is provided by the setting entered on the PFD.

- 13) The flashing cursor moves to the air temperature (TOTAL AIR TEMP) field. Enter the desired air temperature. Press the **ENT** Key when finished. Note that in 'AUTOMATIC' page mode, air temperature is provided by the system outside air temperature.

CREATE A USER WAYPOINT DEFINED BY LATITUDE & LONGITUDE

- 1) Turn the large **FMS** Knob on the Control Unit to select the 'WPT' page group.
- 2) Turn the small **FMS** Knob to select the User WPT Information Page.
- 3) Press the **NEW** Softkey. A waypoint is created at the current aircraft position.
- 4) Enter the desired waypoint name.
- 5) Press the **ENT** Key.
- 6) The cursor is now in the 'WAYPOINT TYPE' field. If desired, the waypoint can be made temporary (deleted automatically when the system is turned off). If the waypoint is to remain in the system, proceed to step 7.
 - a) Turn the large **FMS** Knob one click to the left to highlight 'TEMPORARY'.
 - b) Press the **ENT** Key to place a check-mark in the box. Turn the large **FMS** Knob to place the cursor back in the 'WAYPOINT TYPE' field.
- 7) With the cursor in the 'WAYPOINT TYPE' field, turn the small **FMS** Knob to display a list of waypoint types.
- 8) Turn the small **FMS** Knob to select LAT/LON (latitude and longitude).
- 9) Press the **ENT** Key.

CREATE A USER WAYPOINT DEFINED BY RADIALS FROM OTHER WAYPOINTS

- 1) Turn the large **FMS** Knob on the Control Unit to select the 'WPT' page group.
- 2) Turn the small **FMS** Knob to select the User WPT Information Page.
- 3) Press the **NEW** Softkey. A waypoint is created at the current aircraft position.
- 4) Enter the desired waypoint name.
- 5) Press the **ENT** Key.

- 6) The cursor is now in the 'WAYPOINT TYPE' field. If desired, the waypoint can be made temporary (deleted automatically when the system is turned off). If the waypoint is to remain in the system, proceed to step 7.
 - a) Turn the large **FMS** Knob one click to the left to highlight 'TEMPORARY'.
 - b) Press the **ENT** Key to place a check-mark in the box. Turn the large **FMS** Knob to place the cursor back in the 'WAYPOINT TYPE' field.
- 7) With the cursor in the 'WAYPOINT TYPE' field, turn the small **FMS** Knob to display a list of waypoint types.
- 8) Turn the small **FMS** Knob to select RAD/RAD (radial/radial).
- 9) Press the **ENT** Key.
- 10) The cursor moves to the 'REFERENCE WAYPOINTS' field. With the first waypoint name highlighted, use the **FMS** Knobs to enter the desired waypoint name. Waypoints may also be selected as follows:
 - a) When a flight plan is active, turning the small **FMS** Knob to the left will display a list of the flight plan waypoints.
 - b) Turn the large **FMS** Knob to select the desired waypoint.
 - c) Press the **ENT** Key.

Or:

 - a) Turn the small **FMS** Knob to the left. Initially, a flight plan waypoint list is displayed.
 - b) Turn the small **FMS** Knob to the right to display the 'NRST' airports to the aircraft's current position.
 - c) Turn the large **FMS** Knob to select the desired waypoint.
 - d) Press the **ENT** Key.

Or:

 - a) Turn the small **FMS** Knob to the left. Initially, a flight plan waypoint list is displayed.
 - b) Turn the small **FMS** Knob to the right to display the 'RECENT' waypoints.
 - c) Turn the large **FMS** Knob to select the desired waypoint.
 - d) Press the **ENT** Key.

Or:

- a) Turn the small **FMS** Knob to the left. Initially, a flight plan waypoint list is displayed.
 - b) Turn the small **FMS** Knob to the right to display the 'USER' waypoints.
 - c) Turn the large **FMS** Knob to select the desired waypoint.
 - d) Press the **ENT** Key.
- 11) Press the **ENT** Key. The cursor is displayed in the 'RAD' (radial) field. Enter the desired radial from the reference waypoint.
 - 12) Press the **ENT** Key.
 - 13) Repeat step 10 to enter the next waypoint name.
 - 14) Press the **ENT** Key. The cursor is displayed in the 'RAD' (radial) field for the second waypoint. Enter the desired radial from the reference waypoint.
 - 15) Press the **ENT** Key.
 - 16) Press the **FMS** Knob to remove the flashing cursor.

CREATE A USER WAYPOINT DEFINED BY A RADIAL & DISTANCE FROM ANOTHER WAYPOINT

- 1) Turn the large **FMS** Knob on the MFD Control Unit to select the 'WPT' page group.
- 2) Turn the small **FMS** Knob to select the User WPT Information Page.
- 3) Press the **NEW** Softkey. A waypoint is created at the current aircraft position.
- 4) Enter the desired waypoint name.
- 5) Press the **ENT** Key.
- 6) The cursor is now in the 'WAYPOINT TYPE' field. If desired, the waypoint can be made temporary (deleted automatically when the system is turned off). If the waypoint is to remain in the system, proceed to step 7.
 - a) Turn the large **FMS** Knob one click to the left to highlight 'TEMPORARY'.
 - b) Press the **ENT** Key to place a check-mark in the box. Turn the large **FMS** Knob to place the cursor back in the 'WAYPOINT TYPE' field.
- 7) With the cursor in the 'WAYPOINT TYPE' field, turn the small **FMS** Knob to display a list of waypoint types.
- 8) Turn the small **FMS** Knob to select RAD/DIS (radial/distance).
- 9) Press the **ENT** Key.

- 10)** The cursor moves to the 'REFERENCE WAYPOINTS' field. With the first waypoint name highlighted, use the **FMS** Knobs to enter the desired waypoint name. Waypoints may also be selected as follows:
- a)** When a flight plan is active, turning the small **FMS** Knob to the left will display a list of the flight plan waypoints.
 - b)** Turn the large **FMS** Knob to select the desired waypoint.
 - c)** Press the **ENT** Key.
- Or:**
- a)** Turn the small **FMS** Knob to the left. Initially, a flight plan waypoint list is displayed.
 - b)** Turn the small **FMS** Knob to the right to display the 'NRST' airports to the aircraft's current position.
 - c)** Turn the large **FMS** Knob to select the desired waypoint.
 - d)** Press the **ENT** Key.
- Or:**
- a)** Turn the small **FMS** Knob to the left. Initially, a flight plan waypoint list is displayed.
 - b)** Turn the small **FMS** Knob to the right to display the 'RECENT' waypoints.
 - c)** Turn the large **FMS** Knob to select the desired waypoint.
 - d)** Press the **ENT** Key.
- Or:**
- a)** Turn the small **FMS** Knob to the left. Initially, a flight plan waypoint list is displayed.
 - b)** Turn the small **FMS** Knob to the right to display the 'USER' waypoints.
 - c)** Turn the large **FMS** Knob to select the desired waypoint.
 - d)** Press the **ENT** Key.
- 11)** Press the **ENT** Key. The cursor is displayed in the 'RAD' (radial) field. Enter the desired radial from the reference waypoint.
- 12)** Press the **ENT** Key.
- 13)** The cursor is now displayed in the 'DIS' (distance) field. Enter the desired distance from the reference waypoint.

- 14) Press the **ENT** Key.
- 15) Press the **FMS** Knob to remove the flashing cursor.

DELETE A USER WAYPOINT

- 1) Turn the large **FMS** Knob to select the 'WPT' page group.
- 2) Turn the small **FMS** Knob to select the User WPT Information Page.
- 3) Press the **FMS** Knob to activate the cursor.
- 4) Turn the large **FMS** Knob to the place the cursor in the 'USER WAYPOINT LIST' field.
- 5) Turn the small **FMS** Knob to highlight the desired waypoint.
- 6) Press the **DELETE** Softkey.
- 7) The message 'Would you like to delete the user waypoint?' is displayed. With 'YES' highlighted, press the **ENT** Key.

CREATE A FLIGHT PLAN



NOTE: When creating a flight plan in the Active Flight Plan Window, the first leg is activated automatically after it is created.

Creating an active flight plan:

- 1) Press the **FPL** Key.
- 2) Press the **FMS** Knob to activate the cursor (only on MFD).
- 3) Turn the small **FMS** Knob to display the Waypoint Information Window. (Turning it clockwise displays a blank Waypoint Information Window, turning it counter-clockwise displays the Waypoint Information Window with a waypoint selection submenu allowing selection of active flight plan, nearest, recent, user, or airway waypoints).
- 4) Enter the identifier, facility, or city name of the departure waypoint or select a waypoint from the submenu of waypoints and press the **ENT** Key. The active flight plan is modified as each waypoint is entered.
- 5) Repeat step numbers 3 and 4 to enter each additional flight plan waypoint.
- 6) When all waypoints have been entered, press the **FMS** Knob to remove the cursor.

Creating a stored flight plan:

- 1) Press the **FPL** Key.
- 2) Turn the small **FMS** Knob clockwise to display the Flight Plan Catalog Page.
- 3) Press the **NEW** Softkey; or press the **MENU** Key, highlight 'Create New Flight Plan', and press the **ENT** Key to display a blank flight plan for the first empty storage location.
- 4) Turn the small **FMS** Knob to display the Waypoint Information Window. (Turning it clockwise displays a blank Waypoint Information Window, turning it counter-clockwise displays the Waypoint Information Window with a waypoint selection submenu allowing selection of active flight plan, nearest, recent, user, or airway waypoints).
- 5) Enter the identifier, facility, or city name of the departure waypoint or select a waypoint from the submenu of waypoints and press the **ENT** Key.
- 6) Repeat step numbers 4 and 5 to enter each additional flight plan waypoint.
- 7) When all waypoints have been entered, press the **FMS** Knob to return to the Flight Plan Catalog Page. The new flight plan is now in the list.

IMPORT A FLIGHT PLAN FROM AN SD CARD

- 1) Insert the SD card containing the flight plan in the top card slot on the MFD.
- 2) Press the **FPL** Key on the Control Unit to display the Active Flight Plan Page on the MFD.
- 3) Turn the small **FMS** Knob to select the Flight Plan Catalog Page.
- 4) Press the **FMS** Knob to activate the cursor.
- 5) Turn either **FMS** Knob to highlight an empty or existing flight plan.
- 6) Press the **IMPORT** Softkey.

If an empty flight plan is selected, a list of the available flight plans on the SD card will be displayed.

Or:

If an existing flight plan is selected, an 'Overwrite existing flight plan? OK or CANCEL' prompt is displayed. Press the **ENT** Key to choose to overwrite the selected flight plan and see a list of the available flight plans on the SD card. If overwriting the existing flight plan is not desired, select 'CANCEL' using the **FMS** Knob, press the **ENT** Key, select another existing or empty flight plan, and again press the **IMPORT** Softkey.

- 7) Turn the small **FMS** Knob to highlight the desired flight plan for importing.
- 8) Press the **ENT** Key.

INSERT A WAYPOINT IN THE ACTIVE FLIGHT PLAN

- 1) Press the **FPL** Key to display the active flight plan.
- 2) If required, press the **FMS** Knob to activate the cursor.
- 3) Turn the large **FMS** Knob to highlight the desired flight plan waypoint. The new waypoint is inserted before the highlighted waypoint.
- 4) Turn the small **FMS** Knob. The Waypoint Information Window is now displayed.
- 5) Enter the new flight plan waypoint by one of the following:
 - a) Enter the user waypoint identifier, facility, or city.
 - b) Press the **ENT** Key.

Or:

 - a) Turn the small **FMS** Knob to the left. Initially, a flight plan waypoint list is displayed.
 - b) Turn the small **FMS** Knob to the right to display the 'NRST' airport waypoints to the aircraft's current position.
 - c) Turn the large **FMS** Knob to select the desired waypoint.
 - d) Press the **ENT** Key.

Or:

 - a) Turn the small **FMS** Knob to the left. Initially, a flight plan waypoint list is displayed.
 - b) Turn the small **FMS** Knob to the right to display the 'RECENT' waypoints.
 - c) Turn the large **FMS** Knob to select the desired waypoint.
 - d) Press the **ENT** Key.
 - e) Press the **ENT** Key again to accept the waypoint.

ENTER AN AIRWAY IN A FLIGHT PLAN

- 1) Press the **FPL** Key.
- 2) Press the **FMS** Knob to activate the cursor (not required on the PFD).
- 3) Turn the large **FMS** Knob to highlight the waypoint after the desired airway entry point. If this waypoint is not a valid airway entry point, a valid entry point should be entered at this time.
- 4) Turn the small **FMS** Knob one click clockwise and press the **LD AIRWY** Softkey, or press the **MENU** Key and select "Load Airway". The Select Airway Page is displayed. The **LD AIRWY** Softkey or the "Load Airway" menu item is available only when an acceptable airway entry waypoint has been chosen (the waypoint ahead of the cursor position).
- 5) Turn the **FMS** Knob to select the desired airway from the list, and press the **ENT** Key. Low altitude airways are shown first in the list, followed by "all" altitude airways, and then high altitude airways.
- 6) Turn the **FMS** Knob to select the desired airway exit point from the list, and press the **ENT** Key. 'LOAD?' is highlighted.
- 7) Press the **ENT** Key. The system returns to editing the flight plan with the new airway inserted.

USER-DEFINED HOLDING PATTERNS

A holding pattern can be defined at any active flight plan waypoint, or at the aircraft present position.

Creating a user-defined hold at an active flight plan waypoint:

- 1) Press the **FPL** Key to display the Active Flight Plan Page (MFD) or the Active Flight Plan Window (PFD).
- 2) Press the **FMS** Knob to activate the cursor (not required on the PFD) and turn the large **FMS** Knob to highlight the waypoint for the hold.
- 3) Press the **MENU** Key, highlight 'Hold At Wpt', and press the **ENT** Key. The HOLD AT window appears with the course field highlighted.
- 4) Use the **FMS** Knobs to edit the entry course, and press the **ENT** Key.
- 5) Use the small **FMS** Knob to select 'INBOUND' or 'OUTBOUND' course direction, and press the **ENT** Key.
- 6) Use the small **FMS** Knob to select 'TIME' or 'DIST' length mode, and press the **ENT** Key.

- 7) Use the **FMS** Knobs to edit the length, and press the **ENT** Key.
- 8) Use the small **FMS** Knob to select 'RIGHT' or 'LEFT' turn direction, and press the **ENT** Key.
- 9) Use the **FMS** Knobs to edit the Expect Further Clearance Time (EFC TIME), and press the **ENT** Key.
- 10) Press the **ENT** Key while 'LOAD?' is highlighted to add the hold into the flight plan.

Creating a user-defined hold at the aircraft present position:

- 1) Press the **FPL** Key to display the Active Flight Plan Page (MFD) or the Active Flight Plan Window (PFD).
- 2) Press the **MENU** Key, highlight 'Hold At Present Position', and press the **ENT** Key. The HOLD AT window appears with the Length mode highlighted.
- 3) Use the small **FMS** Knob to select 'TIME' or 'DIST' length mode, and press the **ENT** Key.
- 4) Use the **FMS** Knobs to edit the length, and press the **ENT** Key.
- 5) Use the small **FMS** Knob to select 'RIGHT' or 'LEFT' turn direction, and press the **ENT** Key.
- 6) Use the **FMS** Knobs to edit the Expect Further Clearance Time (EFC TIME), and press the **ENT** Key.
- 7) Press the **ENT** Key while 'ACTIVATE?' is highlighted to immediately activate the hold.

Creating a user-defined hold at a Direct-To waypoint:

- 1) Press a **Direct-to** Key and set up the Direct To waypoint as desired, but select 'HOLD?' instead of 'ACTIVATE?' when finished.
- 2) Use the **FMS** Knobs to edit the entry course, and press the **ENT** Key.
- 5) Use the small **FMS** Knob to select 'INBOUND' or 'OUTBOUND' course direction, and press the **ENT** Key.
- 6) Use the small **FMS** Knob to select 'TIME' or 'DIST' length mode, and press the **ENT** Key.

- 7) Use the **FMS** Knobs to edit the length, and press the **ENT** Key.
- 8) Use the small **FMS** Knob to select 'RIGHT' or 'LEFT' turn direction, and press the **ENT** Key.
- 9) Use the **FMS** Knobs to edit the Expect Further Clearance Time (EFC TIME), and press the **ENT** Key.
- 10) Press the **ENT** Key while 'ACTIVATE?' is highlighted to activate the Direct To with the user-defined hold defined at the Direct To waypoint.

Removing a user-defined hold (created at the aircraft present position or at a Direct-To waypoint):

- 1) Press the **Direct To** Key to display the DIRECT TO Window (PFD or MFD).
- 2) Press the **MENU** Key to display the PAGE MENU with the cursor on the 'Cancel Direct To NAV' selection.
- 3) Press the **ENT** Key. The holding pattern is removed.

Removing a user-defined hold (created at an active flight plan waypoint):

- 1) Press the **FPL** Key to display the Active Flight Plan Page (MFD) or the Active Flight Plan Window (PFD).
- 2) Press the **FMS** Knob to activate the cursor (not required on the PFD) and turn the large **FMS** Knob to highlight the HOLD waypoint.
- 3) Press the **CLR** Key. A 'Remove Holding Pattern?' confirmation window is displayed.
- 4) Select 'OK' and press the **ENT** Key. The holding pattern is removed from the active flight plan. Select 'CANCEL' and press the **ENT** Key to cancel the removal of the holding pattern.

INVERT AN ACTIVE FLIGHT PLAN

- 1) Press the **FPL** Key to display the active flight plan.
- 2) Press the **MENU** Key to display the Page Menu.
- 3) Turn the large **FMS** Knob to highlight 'Invert Flight Plan'.
- 4) Press the **ENT** Key. The original flight plan remains intact in its flight plan catalog storage location.
- 5) With 'OK' highlighted, press the **ENT** Key to invert the flight plan.

REMOVE A DEPARTURE, ARRIVAL, APPROACH, OR AIRWAY FROM A FLIGHT PLAN

- 1) Press the **FPL** Key to display the active flight plan. Press the **FMS** Knob to activate the cursor.
Or, for a stored flight plan:
 - a) Press the **FPL** Key on the MFD.
 - b) Turn the small **FMS** Knob to select the Flight Plan Catalog Page.
 - c) Press the **FMS** Knob to activate the cursor.
 - d) Turn the large **FMS** Knob to highlight the desired flight plan.
 - e) Press the **EDIT** Softkey.
- 2) Turn the large **FMS** Knob to highlight the title for the approach, departure, arrival, or airway to be deleted. Titles appear in white directly above the procedure's waypoints.
- 3) Press the **CLR** Key to display a confirmation window.
- 4) With 'OK' highlighted, press the **ENT** Key to remove the selected procedure or airway.

STORE A FLIGHT PLAN

- 1) After creating a flight plan on either the PFD or MFD, it may be saved by pressing the **MENU** Key.
- 2) Turn the large **FMS** Knob to highlight 'Store Flight Plan' and press the **ENT** Key.
- 3) With 'OK' highlighted, press the **ENT** Key to store the flight plan.

EDIT A STORED FLIGHT PLAN

- 1) Press the **FPL** Key on the MFD and turn the small **FMS** Knob to display the Flight Plan Catalog Page.
- 2) Press the **FMS** Knob to activate the cursor.
- 3) Turn the large **FMS** Knob to highlight the desired flight plan.
- 4) Press the **EDIT** Softkey.
- 5) Turn the large **FMS** Knob to place the cursor in the desired location.
- 6) Enter the changes, then press the **ENT** Key.
- 7) Press the **FMS** Knob to return to the Flight Plan Catalog Page.

DELETE A WAYPOINT FROM THE FLIGHT PLAN

- 1) Press the **FPL** Key to display the active flight plan. Press the **FMS** Knob to activate the cursor.

Or, for a stored flight plan:

- a) Press the **FPL** Key on the MFD.
 - b) Turn the small **FMS** Knob to select the Flight Plan Catalog Page.
 - c) Press the **FMS** Knob to activate the cursor.
 - d) Turn the large **FMS** Knob to highlight the desired flight plan.
 - e) Press the **EDIT** Softkey.
- 2) Turn the large **FMS** Knob to highlight the waypoint to be deleted.
 - 3) Press the **CLR** Key to display a 'REMOVE (Wpt Name)?' confirmation window.
 - 4) With 'OK' highlighted, press the **ENT** Key to remove the waypoint. To cancel the delete request, turn the large **FMS** Knob to highlight 'CANCEL' and press the **ENT** Key.
 - 5) Once all changes have been made, press the **FMS** Knob to remove the cursor.

INVERT AND ACTIVATE A STORED FLIGHT PLAN

- 1) Press the **FPL** Key on the MFD.
- 2) Turn the small **FMS** Knob to select the Flight Plan Catalog Page.
- 3) Press the **FMS** Knob to activate the cursor.
- 4) Turn the large **FMS** Knob to highlight the desired flight plan.
- 5) Press the **INVERT** Softkey. 'Invert and activate stored flight plan?' is displayed.
- 6) With 'OK' highlighted, press the **ENT** Key. The selected flight plan is now inverted and activated. The original flight plan remains intact in its flight plan catalog storage location.

COPY A FLIGHT PLAN

- 1) Press the **FPL** Key on the MFD.
- 2) Turn the small **FMS** Knob to select the Flight Plan Catalog Page.
- 3) Press the **FMS** Knob to activate the cursor.
- 4) Turn the large **FMS** Knob to highlight the flight plan to be copied.

- 5) Press the **COPY** Softkey. A 'Copy to flight plan #?' confirmation window is displayed.
- 6) With 'OK' highlighted, press the **ENT** Key to copy the flight plan. To cancel, turn the large **FMS** Knob to highlight 'CANCEL' and press the **ENT** Key.

DELETE A FLIGHT PLAN

- 1) Press the **FPL** Key on the MFD.
- 2) Turn the small **FMS** Knob to select the Flight Plan Catalog Page.
- 3) Press the **FMS** Knob to activate the cursor.
- 4) Turn the large **FMS** Knob to highlight the flight plan to be deleted.
- 5) Press the **DELETE** Softkey. A 'Delete flight plan #?' confirmation window is displayed.
- 6) With 'OK' highlighted, press the **ENT** Key to delete the flight plan. To cancel, turn the large **FMS** Knob to highlight 'CANCEL' and press the **ENT** Key.

GRAPHICAL FLIGHT PLAN CREATION

- 1) Press the **FPL** Key to display the Active Flight Plan Page on the MFD.
- 2) Press the **Joystick** to activate the map pointer. Use the **Joystick** to move the pointer to the desired point on the map to be inserted as a waypoint in the flight plan.
- 3) The default insertion point is at the end of the flight plan. If the selected waypoint is to be placed anywhere other than the end of the flight plan, press the **FMS** Knob to activate the cursor. Waypoints are inserted *ABOVE* the cursor. Turn the large **FMS** Knob to select the desired insertion point.
- 4) Press the **LD WPT** Softkey. The selected waypoint is inserted at the selected point. The default user waypoint naming is USR000, USR001, USR002, and so on.
- 5) To change the user waypoint name, follow the procedure for modifying a user waypoint.

EXPORT A FLIGHT PLAN TO AN SD CARD

- 1) Insert the SD card into the top card slot on the MFD.
- 2) Press the **FPL** Key on the Control Unit to display the Active Flight Plan Page on the MFD.
- 3) Turn the small **FMS** Knob to select the Flight Plan Catalog Page.
- 4) Press the **FMS** Knob to activate the cursor.
- 5) Turn the large **FMS** Knob to highlight the flight plan to be exported.
- 6) Press the **EXPORT** Softkey.
- 7) Press the **ENT** Key to confirm the export.

PROCEDURES

LOAD AND ACTIVATE A DEPARTURE PROCEDURE

- 1) Press the **PROC** Key.
- 2) Turn the large **FMS** Knob to highlight 'SELECT DEPARTURE'.
- 3) Press the **ENT** Key. The cursor is displayed in the 'DEPARTURE' field with a list of available departures.
- 4) Turn the large **FMS** Knob to highlight the desired departure.
- 5) Press the **ENT** Key. A list of runways may be displayed for the departure. If so, turn either **FMS** Knob to select the desired runway.
- 6) Press the **ENT** Key. The cursor is displayed in the 'TRANSITION' field with a list of available transitions.
- 7) Turn the large **FMS** Knob to highlight the desired transition.
- 8) Press the **ENT** Key.
- 9) With 'LOAD?' highlighted, press the **ENT** Key. The departure is active when the flight plan is active.

ACTIVATE A DEPARTURE LEG

- 1) Press the **FPL** Key on the MFD to display the active flight plan.
- 2) Press the **FMS** Knob to activate the cursor.
- 3) Turn the large **FMS** Knob to highlight the desired waypoint within the departure.
- 4) Press the **ACT LEG** Softkey. A confirmation window showing the selected leg is displayed.
- 5) With 'ACTIVATE' highlighted, press the **ENT** Key.

LOAD AN ARRIVAL PROCEDURE

- 1) Press the **PROC** Key.
- 2) Turn the large **FMS** Knob to highlight 'SELECT ARRIVAL'.
- 3) Press the **ENT** Key. The cursor is displayed in the 'ARRIVAL' field with a list of available arrivals.

- 4) Turn the large **FMS** Knob to highlight the desired arrival.
- 5) Press the **ENT** Key. A list of transitions is displayed for the selected arrival.
- 6) Turn either **FMS** Knob to select the desired transition.
- 7) Press the **ENT** Key. A list of runways may be displayed for the selected arrival.
- 8) Turn the large **FMS** Knob to highlight the desired runway.
- 9) Press the **ENT** Key.
- 10) With 'LOAD?' highlighted, press the **ENT** Key.
- 11) The arrival becomes part of the active flight plan.
- 12) If an altitude associated with a waypoint in an arrival procedure is to be used to calculate vertical guidance perform the following steps:
 - a) Press the **FMS** Knob to activate the cursor.
 - b) Turn the large **FMS** Knob to highlight the desired waypoint altitude.
 - c) Press the **ENT** Key to designate the altitude for use in giving vertical guidance.

ACTIVATE AN ARRIVAL LEG

- 1) Press the **FPL** Key to display the active flight plan.
- 2) Press the **FMS** Knob to activate the cursor.
- 3) Turn the large **FMS** Knob to highlight the desired waypoint within the arrival.
- 4) Press the **ACT LEG** Softkey. A confirmation window showing the selected leg is displayed.
- 5) With 'ACTIVATE' highlighted, press the **ENT** Key.

LOAD AND/OR ACTIVATE AN APPROACH PROCEDURE



NOTE: *If certain GPS parameters (SBAS, RAIM, etc.) are not available, some published approach procedures for the desired airport may not be displayed in the list of available approaches.*

- 1) Press the **PROC** Key.
- 2) Turn the large **FMS** Knob to highlight 'SELECT APPROACH'.

- 3) Press the **ENT** Key. A list of available approaches for the destination airport is displayed.
- 4) Turn either **FMS** Knob to highlight the desired approach.
- 5) Press the **ENT** Key. A list of available transitions for the selected approach procedure is now displayed.
- 6) Turn either **FMS** Knob to select the desired transition. The “Vectors” option assumes vectors will be received to the final course segment of the approach and will provide navigation guidance relative to the final approach course.
- 7) Press the **ENT** Key. The cursor moves to the MINIMUMS field.
- 8) If desired, the DA/MDA for the selected approach procedure may be entered and displayed on the PFD. Turn the small **FMS** Knob in the direction of the green arrow to change the display from OFF to BARO, TEMP COMP or optional RAD ALT.
- 9) Press the **ENT** Key. The cursor moves to the altitude field. Turn the small **FMS** Knob to enter the published DA/MDA for the selected approach procedure.
- 10) Press the **ENT** Key. If BARO, or OFF was selected step 8, proceed to step 11. If TEMP COMP was selected in step 8, the cursor moves to the ‘TEMP AT...’ field. Turn the small **FMS** Knob to enter the temperature at the destination airport. The temperature compensated altitude minimum is displayed below the previously enter minimum altitude value.
- 11) Press the **ENT** Key. ‘LOAD? or ACTIVATE?’ is now displayed with ‘LOAD?’ highlighted.
- 12) Turn the large **FMS** Knob to select either ‘LOAD?’ or ‘ACTIVATE?’.
 Selecting ‘LOAD?’ enters the selected approach procedure into the active flight plan, but is not currently active. Selecting ‘ACTIVATE?’ enters the selected approach procedure into the active flight plan and activates the first leg of the approach.
- 13) Press the **ENT** Key.

ACTIVATE AN APPROACH IN THE ACTIVE FLIGHT PLAN

- 1) Press the **PROC** Key.
- 2) Turn the large **FMS** Knob to highlight 'ACTIVATE APPROACH'.
- 3) Press the **ENT** Key.

ACTIVATE A VECTOR TO FINAL APPROACH FIX

- 1) Press the **PROC** Key.
- 2) Turn the large **FMS** Knob to highlight 'ACTIVATE VECTOR-TO-FINAL'.
- 3) Press the **ENT** Key.
- 4) The final approach course becomes the active leg.

ACTIVATE A MISSED APPROACH IN THE ACTIVE FLIGHT PLAN

- 1) Press the **PROC** Key.
- 2) Turn the large **FMS** Knob to highlight 'ACTIVATE MISSED APPROACH'.
- 3) Press the **ENT** Key. A confirmation window is displayed.
- 4) With 'ACTIVATE' highlighted, press the **ENT** Key.

Or:

Press the Go-around Switch:

TEMPERATURE COMPENSATED ALTITUDE

When temperature compensated altitude is enabled for the loaded approach, the altitudes associated with the approach waypoints are displayed in slanted text.

Approach - KCOS-RNAVGPS 35R LPV			
HABUK iaf	021°	5.7NM	9000FT
FALUR	261°	4.7NM	8600FT
CEGIX faf	351°	5.9NM	7800FT
RW35R map	351°	5.1NM	
6368FT	348°	0.5NM	6368FT
MOGAL mahp			10000FT
HOLD	168°	6.0NM	

Altitudes Displayed Without Temperature Compensation

Approach - KCOS-RNAVGPS 35R LPV			
HABUK iaf	021°	5.7NM	<i>8788FT</i>
FALUR	261°	4.7NM	<i>8418FT</i>
CEGIX faf	351°	5.9NM	<i>7679FT</i>
RW35R map	351°	5.1NM	
6368FT	348°	0.5NM	<i>6355FT</i>
MOGAL mahp			<i>9712FT</i>
HOLD	168°	6.0NM	

Altitudes Displayed With Temperature Compensation

Enabling temperature compensated altitude:

- 1) From the Active Flight Plan Page, press the **MENU** Key. The Page Menu is displayed.
- 2) Turn the **FMS** Knob to highlight 'Temperature Compensation'.
- 3) Press the **ENT** Key. The TEMPERATURE COMPENSATION Window is displayed.
- 4) Use the small **FMS** Knob to select the temperature at the <airport>. The compensated altitude is computed as the temperature is selected.
- 5) Press the **ENT** Key. 'ACTIVATE COMPENSATION?' is highlighted.
- 6) Press the **ENT** Key. The compensated altitudes for the approach are shown in the flight plan.

Disabling temperature compensated altitude:

- 1) From the Active Flight Plan Page, press the **MENU** Key. The Page Menu is displayed.
- 2) Turn the **FMS** Knob to highlight 'Temperature Compensation'.
- 3) Press the **ENT** Key. The TEMPERATURE COMPENSATION Window is displayed.
- 4) Press the **ENT** Key. 'CANCEL COMPENSATION?' is highlighted.
- 5) Press the **ENT** Key. The temperature compensated altitude at the FAF is cancelled.

- Flight Instruments
- EIS
- Nav/Com/XPDR/Audio
- AFCs
- GPS Nav
- Flight Planning
- Procedures**
- Hazard Avoidance
- Additional Features
- Abnormal Operation
- Annun/Alerts
- Appendix
- Index

Blank Page

HAZARD AVOIDANCE

CUSTOMIZING THE HAZARD DISPLAYS ON THE NAVIGATION MAP

- 1) With the Navigation Map Page displayed, press the **MENU** Key to display the Navigation Map Page Menu. The cursor flashes on the 'Map Setup' option.
- 2) Press the **ENT** Key. The Map Setup Menu is displayed. Turn the small **FMS** Knob to select 'Weather' to customize the display of weather features. Select 'Traffic' to customize the display of traffic.
- 3) Press the small **FMS** Knob to return to the Navigation Map Page.





ONBOARD LIGHTNING DETECTION SYSTEM (OPTIONAL)



WARNING: *The lightning detection system system is not intended to be used for hazardous thunderstorm penetration. Weather information on the G1000 MFD is approved for weather avoidance only. Refer to the lightning detection system pilot's guide for detailed operation.*

Displaying Lightning Data on the Navigation Map Page

- 1) Press the **MAP** Softkey.
- 2) Press the **STRMSCP** Softkey. Press the **STRMSCP** Softkey again to remove lightning data from the Navigation Map Page.

Lightning Age	Symbol
Strike is less than 6 seconds old	
Strike is between 6 and 60 seconds old	
Strike is between 1 and 2 minutes old	
Strike is between 2 and 3 minutes old	

Select 'Cell' or 'Strike' as the Lightning Mode

- 1) Press the **MENU** Key (with the Navigation Map Page displayed).
- 2) Turn either **FMS** Knob to highlight 'Map Setup'.
- 3) Press the **ENT** Key.
- 4) Turn the small **FMS** Knob to highlight 'Weather'.

- 5) Press the **ENT** Key.
- 6) Turn the large **FMS** Knob to place the cursor in the 'STRMSCP MODE' field.
- 7) Turn the small **FMS** Knob to display the 'Cell/Strike' window.
- 8) Turn either **FMS** Knob to select 'Cell' or 'Strike'. Press the **ENT** Key.
- 9) Push the **FMS** Knob to return to the Navigation Map Page.

Clear Lightning Data from the Navigation Map Page

- 1) Press the **MENU** Key (with the Navigation Map Page displayed).
- 2) Turn either **FMS** Knob to highlight the 'Clear Stormscope® Lightning' field and press the **ENT** Key.



NOTE: If heading input is lost, strikes and/or cells must be cleared manually after the execution of each turn. This is to ensure that the strike and/or cell positions are depicted accurately in relation to the nose of the aircraft.

Stormscope Page

- 1) Turn the large **FMS** Knob until the Map Page group is selected.
- 2) Turn the small **FMS** Knob until the Stormscope Page is selected.

Change the Lightning Mode Between 'Cell' and 'Strike'

- 1) Select the Stormscope Page.
- 2) Press the **MODE** Softkey. The **CELL** and **STRIKE** Softkeys are displayed. Press the **CELL** Softkey to display 'CELL' data or press the **STRIKE** Softkey to display 'STRIKE' data. 'CELL' or 'STRIKE' is displayed in the mode box located in the upper left corner of the Stormscope Page.



NOTE: "Cell mode" uses a clustering program to identify clusters of electrical activity that indicate cells.

Change the Viewing Mode Between 360° and 120°

- 1) Select the Stormscope Page.
- 2) Press the **VIEW** Softkey. The **360** and **ARC** Softkeys are displayed. Press the **360** Softkey to display a 360° viewing area or press the **ARC** Softkey to display a 120° viewing area.

Press the **CLEAR** Softkey to remove all lightning data from the display.

SIRIUSXM WEATHER (OPTIONAL)



WARNING: Do not use data link weather information for maneuvering in, near, or around areas of hazardous weather. Information contained within data link weather products may not accurately depict current weather conditions.

Displaying SiriusXM Weather on the Navigation Map Page

- 1) Press the **MAP** Softkey.
- 2) Press the **NEXRAD** or **XM LTNG** Softkey to display the desired weather. Press the applicable softkey again to remove weather data from the Navigation Map Page.

Display METAR and TAF information on the Airport Information Page

- 1) Turn the large **FMS** Knob to select the WPT Page Group.
- 2) Turn the small **FMS** Knob to select the Airport Information Page.
- 3) Press the **WX** Softkey to display METAR and TAF text (METAR and TAF information is updated every 12 minutes).

Displaying Weather on the Weather Data Link Page

- 1) Turn the large **FMS** Knob to select the Map Page Group.
- 2) Turn the small **FMS** Knob to select the Weather Data Link Page.
- 3) Press the available softkeys to select the desired SiriusXM Weather product.
- 4) Press the **LEGEND** Softkey to view the legends for the selected products. If necessary, turn either **FMS** Knob to scroll through the list. Press the small **FMS** Knob or the **ENT** Key to return to the map.

Map Panning Information – Weather Data Link Page

- 1) Push in the **Joystick** to display the panning arrow.
- 2) Move the **Joystick** to place the panning arrow on AIRMETs, TFRs, METARs, or SIGMETs.
- 3) Press the **ENT** Key to display pertinent information for the selected product.

Note that pressing the **ENT** Key when panning over an AIRMET or a SIGMET displays an information box that shows the text of the report. Panning over an airport with METAR information does not display more information but allows the user to press the **ENT** Key and select that Airport's Information Page to display the text of the report. Pressing the **ENT** Key when panning over a TFR displays TFR specific information.

SiriusXM Weather Products and Symbols

SiriusXM Weather Product	Symbol	Expiration Time (Minutes)	Broadcast Rate (Minutes)
Next-generation Radar (NEXRAD)		30	5 (U.S.) 10 (Canada)
Cloud Top (CLD TOP)		60	15 (69/69A) 30 (69/69A SXM)
Echo Top (ECHO TOP)		30	7.5
SiriusXM Lightning (XM LTNG)		30	5
Cell Movement (CELL MOV)		30	12
SIGMETs/AIRMETs (SIG/AIR)		60	12
Meteorological Aerodrome Report (METARs)		90	12
City Forecast (CITY)		90	12
Surface Analysis (SFC)		60	12
Freezing Levels (FRZ LVL)		120	12
Winds Aloft (WIND)		90	12
County Warnings (COUNTY)		60	5
Cyclone Warnings (CYCLONE)		60	12

SiriusXM Weather Product	Symbol	Expiration Time (Minutes)	Broadcast Rate (Minutes)
Icing Potential (CIP and SLD) (ICNG)		90	22
Pilot Weather Report (PIREPs)		90	12
Air Report (AIREPs)		90	12
Turbulence (TURB)		180	12
No Radar Coverage	no product image	30	5
Temporary Flight Restrictions (TFRs)	no product image	60	12
Terminal Aerodrome Reports (TAFs)	no product image	60	12

SiriusXM Weather Product Symbols and Data Timing

GARMIN CONNEXT WEATHER (OPTIONAL)



WARNING: Do not use data link weather information for maneuvering in, near, or around areas of hazardous weather. Information contained within data link weather products may not accurately depict current weather conditions.

Weather data is provided when the pilot initiates either a manual or automatic Connex Weather data request on the Connex Weather Data Link Page on the MFD. No weather data is displayed until the first Connex Weather Data Request is made.

Registering with Garmin Connex

A subscriber account must be established prior to receiving Worldwide Weather products. Contact Garmin Flight Data Services at <https://fly.garmin.com/fly-garmin/support/applications/satelliteservices/> or by calling 1-866-739-5687 in the United States or (011) 913-440-1135.

After a subscriber account has been established, the system must be registered for data link features such as reporting services or Connex Worldwide Weather.

- Flight Instruments
- EIS
- Nav/Com/XPDR/Audio
- AFCS
- GPS Nav
- Flight Planning
- Procedures
- Hazard Avoidance
- Additional Features
- Abnormal Operation
- Annun/Alerts
- Appendix
- Index

Registration is accomplished by entering the required access code. This process is only performed when initially setting up the system for Garmin Connex services.

Registering the System for Data Link Services

- 1) With the aircraft outside and having a clear view of the sky, turn the large **FMS** Knob on the MFD to select the AUX page group.
- 2) Turn the small **FMS** Knob to select the AUX-SYSTEM STATUS. Note the System ID number in the AIRFRAME field.
- 3) Turn the large **FMS** Knob to select the MAP Page group.
- 4) Turn the small **FMS** Knob to select the MAP-WEATHER DATA LINK Page.
- 5) Press the **MENU** Key. If necessary, select 'Display Connex Weather'.
- 6) Press **ENT** Key. The 'GARMIN FLIGHT DATA SERVICE REGISTRATION' Window is now displayed.
- 7) Press the **MENU** Key. The Page Menu window is now displayed.
- 8) Using the **FMS** Knob enter the access code obtained from Garmin Flight Data Services in the ACCESS CODE field.
- 9) Press the **ENT** Key. REGISTER will now be highlighted.
- 10) Press the **ENT** Key. System registration is complete when 'REGISTERED' is displayed in the STATUS field.

Accessing Connex Weather Products







- 1) Turn the large **FMS** Knob to select the Map Page Group.
- 2) Turn the small **FMS** Knob to select the Connex Weather Data Link Page.

When a weather product is selected for display on the Connex Weather Data Link Page, a box containing a symbol for the product and its age (in minutes) are shown in the upper right. If weather data has not been requested, 'N/A' is shown next to the product symbol instead of age. The age of the weather product is based on the time difference between when the data was assembled on the ground and the current GPS time. Weather products are updated continuously or refreshed at specific intervals (defined in the **Refresh Rate** column in the following table).

If for any reason, a weather product is not refreshed within the defined **Expiration Time** intervals, the data is considered expired and is removed from the display. The age of the expired product is replaced by dashes. If more than half of the expiration time has elapsed, the color of the product age readout changes to yellow.

The refresh rate represents the interval at which the Garmin Connex servers make

available the most current known weather data. It does not necessarily represent the rate at which new content is received from weather sources.

Garmin Connex Weather Product	Symbol	Expiration Time (Minutes)	Refresh Rate (Minutes)
Radar Precipitation (PRECIP)		30	U.S.: 3* Canada: 3*† Europe: 15 Australia: 15^
Infrared Satellite (IR SAT)		60	30
Data Link Lightning (DL LTNG)		30	Continuous
SIGMETs/AIRMETs (SIG/AIR)		60	Continuous
Meteorological Aerodrome Report (METARs)		90	Continuous
Winds Aloft (WIND)		90	Continuous
Pilot Weather Report (PIREPs)		90	Continuous
Temporary Flight Restrictions (TFRs)	no product image	60	Continuous
Terminal Aerodrome Forecasts (TAFs)	no product image	60	Continuous

* The composite precipitation image is updated every 3 minutes, but individual radar sites may take between 3 and 10 minutes to provide new data.

† Canadian radar precipitation data provided by Environment Canada.

^ Australian radar precipitation data provided by the Australian Bureau of Meteorology.

Garmin Connex Weather Product Symbols and Data Timing

- Flight Instruments
- EIS
- Nav/Com/XPDR/Audio
- AFCS
- GPS Nav
- Flight Planning
- Procedures
- Hazard Avoidance
- Additional Features
- Abnormal Operation
- Annual Alerts
- Appendix
- Index

Setting Up and Customizing the Connex Weather Data Link Page

- 1) Select the Connex Weather Data Link Page.
- 2) Press the **MENU** Key.
- 3) With 'Weather Setup' highlighted, press the **ENT** Key.
- 4) Turn the small **FMS** Knob to select 'Product Group 1' or 'Product Group 2', and press the **ENT** Key.
- 5) Turn the large **FMS** Knob or press the **ENT** Key to scroll through product selections.
- 6) Turn the small **FMS** Knob to scroll through options for each product (ON/OFF, range settings, etc.).
- 7) Press the **ENT** Key to select an option.
- 8) Press the **FMS** Knob or **CLR** Key to return to the Connex Weather Data Link Page with the changed settings.

Restoring Default Connex Weather Data Link Page Settings

- 1) Select the Connex Weather Data Link Page.
- 2) Press the **MENU** Key.
- 3) With 'Weather Setup' highlighted, press the **ENT** Key.
- 4) Press the **MENU** Key.
- 5) Highlight the desired default(s) to restore (all or for selection) and press **ENT** Key.

Switching Between Connex and SiriusXM Weather Sources

- 1) Turn the large **FMS** Knob on the MFD to select the MAP page group.
- 2) Turn the small **FMS** Knob to select the desired Weather Data Link Page.
- 3) Press the **MENU** Key.
- 4) Turn the large **FMS** Knob to select 'Display Connex Weather', or 'Display XM Weather' (choice dependent on current weather source) and press the **ENT** Key.

Viewing Legends for Displayed Connex Weather Products

- 1) Select the Connex Weather Data Link Page.
- 2) Press the **LEGEND** Softkey to display the legends for the displayed weather products.
Or:
 - a) Press the **MENU** Key.
 - b) Select 'Weather Legend' and press the **ENT** Key.
- 3) Turn the **FMS** Knob to scroll through the legends if more are available than fit in the window.
- 4) To remove the Legend Window, press the **LEGEND** Softkey, the **ENT** or the **CLR** Key, or press the **FMS** Knob.

Setting Up and Customizing Weather Data for the Navigation Map Page

- 1) Select the Navigation Map Page.
- 2) Press the **MENU** Key.
- 3) With 'Map Setup' highlighted, press the **ENT** Key.
- 4) Turn the small **FMS** Knob to select the 'Weather' Group and press the **ENT** Key.
- 5) Turn the large **FMS** Knob or press the **ENT** Key to scroll through product selections.
- 6) Turn the small **FMS** Knob to scroll through options for each product (ON/OFF, range settings).
- 7) Press the **ENT** Key to select an option.
- 8) Press the **FMS** Knob or **CLR** Key to return to the Navigation Map Page with the changed settings.

Connex Weather Data Requests

The Connex Data Request window provides the flight crew with the options to define the requested weather coverage area(s), choose automatic weather update intervals (if desired), and the ability to send or cancel weather data requests. The window also displays the status of the Connex data request process.

Requesting Connex Weather Data Manually

- 1) Select the Connex Weather Data Link Page.
- 2) Press the **MENU** Key.
- 3) With 'Connex Weather Request' highlighted, press the **ENT** Key.
- 4) Turn the large **FMS** Knob to highlight the desired coverage option(s) and press the **ENT** Key to check or uncheck one or more of the following coverage selections:
 - **PRESENT POSITION** – Requests data based on current location.
 - **DESTINATION** – Requests data based on active flight plan destination (if the flight plan contains no destination, dashes '-----' are displayed.)
 - **FPL** – Requests data based on active flight plan. Turn the small **FMS** Knob to select the desired flight plan look-ahead distance option (or choose 'REMAINING FPL' to request the remainder of the flight plan).
 - **WAYPOINT** – Requests data based on any valid waypoint.
- 5) Turn the large **FMS** Knob highlight to the 'DIAMETER / RTE WIDTH' distance field and turn the small **FMS** Knob to select the desired diameter and route width of the request, then press the **ENT** Key.
- 6) Turn the large **FMS** Knob until the 'SEND REQ' button is highlighted. Press the **ENT** Key to initiate the request immediately or press the **FMS** Knob to return to the Connex Data Link Page without requesting data.

During a Connex Data Request, the Request Status box initially displays "Contacting Connex...". Once a connection is established, the Request Status Box displays "Receiving Wx Data... Time Remaining:" with an estimated data transfer time (either minutes or seconds). If desired, the Connex Data Request window may be closed while the data request is processing by pressing the **FMS** Knob; the data request will continue to process in the background. Connex Data Requests typically take between 1 to 4 minutes to complete depending on the size of the selected weather coverage area and Iridium signal strength.

The system retrieves all available Worldwide Weather products within the selected coverage area during an initial Connex Data Request, regardless of which products (if any) are currently enabled for display. On subsequent requests, previously retrieved textual data (such as METARs and TAFs) is retained if it has not expired, while new textual weather data matching the current coverage area and all graphical weather data

is downloaded during every data request.

If the system cannot complete a Connex weather data request, one or more messages will appear in the request status window as shown in the following table.

Weather Request Status Message	Description
Auto requests inhibited Send manual request to reset.	The system has disabled automatic weather data requests due to excessive errors. Automatic weather data requests have stopped. Send a manual weather data request to resume automatic updates.
Auto update retry: ## Seconds	The system will attempt another automatic weather data request after an error occurred during the previous request. Timer counts down until the next automatic request occurs.
Connex Comm Error [2]	A communications error has occurred with the GIA. The system should be serviced.
Connex Comm Error [4]	This occurs if multiple automatic weather data requests have recently failed, or the GDL 59 or a GIA is off-line.
Connex Comm Error [5]	The Iridium or Connex networks are not accessible. Check Iridium signal strength. If this error persists, the system should be serviced.
Connex Comm Error [6]	A communications error has occurred. If this error persists, the system should be serviced.
Connex Comm Error [7]	A weather data transfer has timed out. Check Iridium signal strength and re-send the data request.
Connex Comm Error [8]	A server error has occurred or invalid data received.
Connex Login Invalid	There is a problem with the Connex registration. Contact Garmin Flight Data Services at 1-866-739-5687 in the United States or (011) 913-440-1135 for assistance.
Connex Server Temporarily Inop	The Connex weather data server is temporarily out of service, but is expected to return to service in less than 30 minutes.
Connex Server Inop	The Connex weather data server will be out of service for at least 30 minutes.

Weather Request Status Message	Description
Invalid Coverage Area	The weather data request coverage area does not contain at least one of the following: a waypoint, a flight plan, or a flight plan destination. Verify at least one of the coverage options is enabled (checked) and contains required criteria, then re-send the data request.
No Connex Subscription	The system is not be currently subscribed to Connex, or the access code is incorrect. Verify the access code. Contact Garmin Flight Data Services at 1-866-739-5687 in the United States or (011) 913-440-1135 for assistance.
Reduce Request Area	The Connex weather data request area exceeds size limits. Reduce weather coverage area and re-send data request.
Request Cancelled	The user has cancelled a Connex weather data request.
Requested area too large. Reduce coverage area.	The size of the Connex weather data request has exceeded limits. Reduce the size of the coverage area and try the weather data request again.
Request Failed - Try Again	The weather data request timed-out. Re-send data request.
Transfer Preempted	The data link is busy. Retry request later.

Canceling a Connex Weather Data Request in Progress

- 1) Select the Connex Weather Data Link Page.
- 2) Press the **MENU** Key.
- 3) With 'Connex Data Request' highlighted, press the **ENT** Key.
- 4) Turn the large **FMS** Knob to select 'CANCEL REQ' and press the **ENT** Key. The request status box indicates 'Request Cancelled'.
- 5) Press the **FMS** Knob to return to the Connex Weather Data Link Page.

Enabling Automatic Connex Data Requests

- 1) Select the Connex Weather Data Link Page.
- 2) Press the **MENU** Key.
- 3) With 'Connex Weather Request' highlighted, press the **ENT** Key.

- 4) Choose the desired weather coverage options.
- 5) Turn the large **FMS** Knob to select the 'UPDATE RATE' setting. Then turn the small **FMS** Knob to highlight the desired automatic update frequency (OFF, 5 Min, 10 Min, 15 Min, 20 Min, 25 Min, 30 Min, 45 Min, or 60 Min), then press the **ENT** Key.
- 6) The 'SEND REQ' button is highlighted and a countdown timer is displayed in the 'REQUEST STATUS' based on the currently selected update rate. Press the **ENT** Key to immediately send an immediate Connex Data Request.

Or:

Press the **FMS** Knob to return to the Connex Weather Data Link Page.

Worldwide Weather Products

Precipitation

Precipitation data is not real-time. The lapsed time between collection, processing, and dissemination of radar images can be significant and may not reflect the current radar synopsis. Due to the inherent delays and the relative age of the data, it should be used for long-range planning purposes only.



NOTE: Precipitation data cannot be displayed on the Navigation Map Page at the same time as terrain.

Displaying Precipitation Weather Information

- 1) Press the **MAP** Softkey (for the PFD Inset Map, press the **INSET** Softkey). This step is not necessary on the Connex Weather Data Link Page.
- 2) Press the **PRECIP** Softkey.

Radar data shown represents lowest level, base reflectivity, of radar returns. The display of the information is color-coded to indicate the weather severity level. All weather product legends can be viewed on the Connex Weather Data Link Page. For the Precipitation legend, press the **LEGEND** Softkey when Precipitation is selected for display.

Precipitation Limitations

Radar images may have certain limitations:

- Radar base reflectivity does not provide sufficient information to determine cloud layers or precipitation characteristics (wet hail vs. rain). For example, it is not possible to distinguish between wet snow, wet hail, and rain.
- Radar base reflectivity is sampled at the minimum antenna elevation angle. An individual radar site cannot depict high altitude storms at close ranges. It has no information about storms directly over the site.
- When zoomed in to a range of 30 nm, each square block on the display represents an area of four square kilometers.

The following may cause abnormalities in displayed radar images:

- Ground clutter
- Strokes and spurious radar data
- Sun strokes (when the radar antenna points directly at the sun)
- Interference from buildings or mountains, which may cause shadows
- Metallic dust from military aircraft, which can cause alterations in radar scans

Infrared Satellite

Infrared Satellite (IR SAT) data depicts cloud top temperatures from satellite imagery. Brighter cloud top colors indicate cooler temperatures occurring at higher altitudes.

Displaying Cloud Tops information

- 1) Select the Connex Weather Data Link Page.
- 2) Press the **IR SAT** Softkey.

To display the Infrared Satellite legend, press the **LEGEND** Softkey when Infrared Satellite data is selected for display.

Data Link Lightning

Lightning data shows the approximate location of cloud-to-ground lightning strikes. A strike icon represents a strike that has occurred within a two-kilometer region. Neither cloud-to-cloud nor the exact location of the lightning strike is displayed.

If the aircraft is also equipped with an on-board lightning detection system, only one lightning product may be enabled for display at a time.

Displaying Data Link Lightning information

- 1) Press the **MAP** Softkey (for the PFD Inset Map, press the **INSET** Softkey). This step is not necessary on the Connex Weather Data Link Page.
- 2) Press the **DL LTNG** Softkey.

To display the Data Link Lightning legend on the Weather Data Link Page, press the **LEGEND** Softkey when Data Link Lightning is selected for display.

SIGMETs and AIRMETs

The entire SIGMET or AIRMET is displayed as long as any portion of it is occurring within the coverage area of the Connex data request.

Displaying SIGMETs and AIRMETs

- 1) Select the Connex Weather Data Link Page.
- 2) Press the **SIG/AIR** Softkey.
- 3) To view the text of the SIGMET or AIRMET, press the **RANGE** Knob and move the Map Pointer over the icon.
- 4) Press the **ENT** key.

To display the SIGMET and AIRMET legend, press the **LEGEND** Softkey when SIGMETs and AIRMETs are selected for display.

METARs and TAFs



NOTE: *METAR information is only displayed within the installed navigation database service area.*

METAR and TAF text are displayed on the WPT-Weather Information Page. TAF information is displayed in its raw form when it is available.

Displaying METAR and TAF text

- 1) On the Connex Weather Data Link Page, press the **METAR** Softkey.
- 2) Press the **RANGE** Knob and pan to the desired airport.
- 3) Press the **ENT** Key. The Weather Information Page is shown with METAR and TAF text.
- 4) Use the **FMS** Knob or the **ENT** Key to scroll through the METAR and TAF text. METAR text must be completely scrolled through before scrolling through the TAF text.

- 5) Press the **FMS** Knob or the **CLR** Key to return to the Connex Weather Data Link Page.

Or:

- 1) Select the Weather Information Page.
 - a) Turn the large **FMS** Knob to select the Waypoint Page Group.
 - b) Press the **WX** Softkey to select the Weather Information Page.
- 2) Press the **FMS** Knob to display the cursor.
- 3) Use the **FMS** Knob to enter the desired airport and press the **ENT** Key.
- 4) Use the **FMS** Knob or the **ENT** Key to scroll through the METAR and TAF text. Note that the METAR text must be completely scrolled through before scrolling through the TAF text.

To display the METAR legend on the Connex Weather Data Link Page, press the **LEGEND** Softkey when METARs are selected for display.

Winds Aloft

Winds Aloft data shows the forecasted wind speed and direction at the surface and at selected altitudes. Altitude can be displayed in 3,000-foot increments up to 42,000 feet MSL.

Displaying Winds Aloft data

- 1) Select the Connex Weather Data Link Page.
- 2) Press the **MORE WX** Softkey.
- 3) Press the **WIND** Softkey.
- 4) Press the desired altitude level: **SFC** (surface) up to 42,000 feet. Press the **NEXT** or **PREV** Softkey to cycle through the altitude softkeys. The **WIND** Softkey label changes to reflect the altitude selected.

To display the Winds Aloft legend, press the **LEGEND** Softkey when Winds Aloft is selected for display.

PIREPs

Pilot Weather Reports (PIREPs) describe in-flight weather encountered by pilots. A PIREP may contain unforecast adverse weather conditions, such as low in-flight visibility, icing conditions, wind shear, turbulence, and type of aircraft flown. PIREPs are issued as either Routine (UA) or Urgent (UUA).

Displaying PIREP text

- 1) Select the Connex Weather Data Link Page.
- 2) Press the **MORE WX** Softkey.
- 3) Press the **PIREPS** Softkey.
- 4) Press the **RANGE** Knob and pan to the desired weather report. A gray circle will appear around the weather report when it is selected.
- 5) Press the **ENT** Key. The PIREP text is first displayed in a decoded fashion, then as raw text.
- 6) Use the **FMS** Knob or the **ENT** Key to scroll through the PIREP text.
- 7) Press the **FMS** Knob or the **CLR** Key to close the PIREP text window and return to the Connex Weather Data Link Page.

To display the PIREP or AIREP legend, press the **LEGEND** Softkey when PIREPs or AIREPs are selected for display.

The PIREP color is determined by the type (routine or urgent).

FIS-B WEATHER



WARNING: Do not use data link weather information for maneuvering in, near, or around areas of hazardous weather. Information contained within data link weather products may not accurately depict current weather conditions.



WARNING: Do not use the indicated data link weather product age to determine the age of the weather information shown by the data link weather product. Due to time delays inherent in gathering and processing weather data for data link transmission, the weather information shown by the data link weather product may be significantly older than the indicated weather product age.

The optional GDL 88 receives Flight Information Services - Broadcast (FIS-B) weather data from a network of UAT ground-based transceivers (GBTs).

FIS-B weather data reception requires the aircraft being within range and line-of-sight of an operating GBT broadcasting FIS-B weather data. Reception may be affected by factors including altitude or terrain.

Reception of FIS-B weather data occurs automatically without any pilot action. FIS-B broadcasts provide weather data in a repeating cycle which may take approximately ten minutes to transmit all available weather data. Therefore, not all available weather data may be available immediately upon initial FIS-B signal acquisition.



Viewing the Weather Data Link (FIS-B) Page

- 1) Turn the large **FMS** Knob to select the Map Page Group.
- 2) Turn the small **FMS** Knob to select the Weather Data Link (FIS-B, XM, or CNXT) Page.
- 3) If the page title displays a weather data link weather source other than 'FIS-B', such as 'XM' or 'CNXT', proceed to the following steps to change the data link weather source.
- 4) Press the **MENU** Key.
- 5) Turn the small **FMS** Knob to select 'Display FIS-B Weather'.
- 6) Press the **ENT** Key. The page title will display 'MAP - WEATHER DATA LINK (FIS-B)' to indicate FIS-B is now the selected data link weather source.

Enabling/Disabling FIS-B Weather

- 1) Select the Weather Data Link (FIS-B) Page.
- 2) Press the **MENU** Key.
- 3) Turn the small **FMS** Knob to highlight 'Enable FIS-B Weather' or 'Disable FIS-B Weather', and press the **ENT** Key.

FIS-B Weather Product	Symbol	Expiration Time (Minutes)	Broadcast Rate (Minutes)
NEXRAD Composite (US)		30	15
NEXRAD Composite (Regional)		30	2.5
Meteorological Aerodrome Report (METARs)		90	5
Pilot Weather Report (PIREPs)		90	10

FIS-B Weather Product	Symbol	Expiration Time (Minutes)	Broadcast Rate (Minutes)
Winds Aloft (WIND)		90	10
SIGMETs/AIRMETs (SIG/AIR)		60	5
No Radar Coverage	no product image	30	2.5
Terminal Aerodrome Forecast	no product image	60	10
Temporary Flight Restriction (TFR)	no product image		10

Weather Product Symbols and Data Timing

Setting Up and Customizing the Weather Data Link (FIS-B) Page

- 1) Select the Weather Data Link (FIS-B) Page.
- 2) Press the **MENU** Key.
- 3) With 'Weather Setup' highlighted, press the **ENT** Key.
- 4) Turn the small **FMS** Knob to select 'Product Group 1', and press the **ENT** Key.
- 5) Turn the large **FMS** Knob or press the **ENT** Key to scroll through product selections.
- 6) Turn the small **FMS** Knob to scroll through options for each product (ON/OFF, range settings, etc.).
- 7) Press the **ENT** Key to select an option.
- 8) Press the **FMS** Knob or **CLR** Key to return to the Weather Data Link (FIS-B) Page with the changed settings.

Setting Up and Customizing FIS-B Weather on the Navigation Map Page

- 1) Select the Navigation Map Page.
- 2) Press the **MENU** Key.
- 3) With 'Map Setup' highlighted, press the **ENT** Key.

- 4) Turn the small **FMS** Knob to select the 'Weather' Group and press the **ENT** Key.
- 5) Turn the large **FMS** Knob or press the **ENT** Key to scroll through product selections.
- 6) Turn the small **FMS** Knob to scroll through options for each product (ON/OFF, range settings).
- 7) Press the **ENT** Key to select an option.
- 8) Press the **FMS** Knob or **CLR** Key to return to the Navigation Map Page with the changed settings.

Displaying/Removing the Weather Product Information Box on the PFD Inset Map

- 1) On the PFD, press the **INSET** Softkey.
- 2) Press the **WX LGND** Softkey.
- 3) To remove the weather product information box, press the **WX LGND** Softkey again.

Viewing Legends for Displayed Weather Products on the Weather Data Link (FIS-B) Page

- 1) Select the Weather Data Link (FIS-B) Page.
- 2) Press the **LEGEND** Softkey to display the legends for the displayed weather products.
Or:
 - a) Press the **MENU** Key.
 - b) Select 'Weather Legend' and press the **ENT** Key.
- 3) To remove the Legend Window, press the **LEGEND** Softkey, the **ENT** or the **CLR** Key, or press the **FMS** Knob.

Viewing Legends for Displayed Weather Products on the Navigation Map Page

- 1) Select the Navigation Map Page.
- 2) Press the **MAP** Softkey.
- 3) Press the **LEGEND** Softkey (available if one or more FIS-B weather products are enabled for display).

- 4) To remove the Legend Window, press the **LEGEND** Softkey, the **ENT** or the **CLR** Key, or press the **FMS** Knob.

Displaying NEXRAD Data

- 1) Press the **MAP** Softkey (for the PFD Inset Map, press the **INSET** Softkey). This step is not necessary on the Weather Data Link (FIS-B) Page.
- 2) Press the **NEXRAD-C** Softkey. This softkey becomes the **US** Softkey. A mosaic of NEXRAD data for the continental United States (CONUS) is displayed.
- 3) To display the regional version of the NEXRAD weather product, press the **US** Softkey. Softkey becomes the **RGNL** Softkey.
- 4) To remove the NEXRAD weather product, press the **RGNL** Softkey. Softkey becomes the **NEXRAD-C** Softkey.

Displaying SIGMETs and AIRMETS

- 1) Select the Weather Data Link (FIS-B) Page.
- 2) Press the **SIG/AIR** Softkey.
- 3) To view the text of the SIGMET or AIRMET, press the **Joystick** and move the Map Pointer over the icon.
- 4) Press the **ENT** key.

Displaying METAR and TAF Text

- 1) On the Weather Data Link (FIS-B) Page, press the **METAR** Softkey.
 - 2) Press the **Joystick** and pan to the desired airport.
 - 3) Press the **ENT** Key. The Weather Information Page is shown with METAR and TAF text.
 - 4) Use the **FMS** Knob or the **ENT** Key to scroll through the METAR and TAF text. METAR text must be completely scrolled through before scrolling through the TAF text.
 - 5) Press the **FMS** Knob or the **CLR** Key to return to the Weather Data Link (FIS-B) Page.
- Or:**

- 1) Select the Weather Information Page.
 - a) Turn the large **FMS** Knob to select the Waypoint Page Group.
 - b) Press the **WX** Softkey to select the Weather Information Page.
- 2) Press the **FMS** Knob to display the cursor.
- 3) Use the **FMS** Knob to enter the desired airport and press the **ENT** Key.
- 4) Use the **FMS** Knob or the **ENT** Key to scroll through the METAR and TAF text. Note that the METAR text must be completely scrolled through before scrolling through the TAF text.

Displaying Raw METAR Text on the Active Flight Plan Page

- 1) Select the Active Flight Plan Page on the MFD.
- 2) Press the **FMS** Knob to activate the cursor.
- 3) Turn the large **FMS** Knob to highlight the desired waypoint. The METAR text will appear in the 'SELECTED WAYPOINT WEATHER' window below.
- 4) When finished, press the **FMS** Knob to remove the cursor or press the **FPL** Key to exit the Active Flight Plan Page.

Displaying Winds Aloft Information

- 1) Select the Weather Data Link (FIS-B) Page.
- 2) Press the **MORE WX** Softkey.
- 3) Press the **WIND OFF** Softkey.
- 4) Press the softkey for the desired altitude. Press the **NEXT** or **PREV** Softkey to cycle through the altitude softkeys. The **WIND** Softkey label changes to reflect the altitude selected.

Enabling/Disabling Predicted Temperatures with Winds Aloft Data

- 1) Select the Weather Data Link (FIS-B) Page.
- 2) Press the **MENU** Key.
- 3) Turn the small **FMS** Knob to highlight 'Weather Setup' and press the **ENT** Key.
- 4) Turn the small **FMS** Knob to highlight 'PRODUCT GROUP 1' and press the **ENT** Key.
- 5) Turn the small **FMS** Knob to highlight the Temp (•) 'ON' or 'OFF' field, then press the **ENT** Key.
- 6) When finished, push the **FMS** Knob or the **CLR** Key.

Displaying PIREP Text

- 1) Select the Weather Data Link (FIS-B) Page.
- 2) Press the **MORE WX** Softkey.
- 3) Press the **PIREPS** Softkey.
- 4) Press the **Joystick** and pan to the desired weather report. A gray circle will appear around the weather report when it is selected.
- 5) Press the **ENT** Key. The PIREP text is first displayed in a decoded fashion, followed by the original text. Note the original text may contain additional information not shown in the decoded version.
- 6) Use the **FMS** Knob or the **ENT** Key to scroll through the PIREP text.
- 7) Press the **FMS** Knob or the **CLR** Key to close the PIREP text window and return to the Weather Data Link (FIS-B) Page.

Displaying TFR Data

- 1) Select the Weather Data Link (XM) Page or Navigation Map Page.
- 2) Press the **Joystick** and pan the map pointer over a TFR to highlight it. The system displays TFR summary information above the map.
- 3) Press the **ENT** Key. The system displays a pop-up menu.
- 4) If necessary, turn the **FMS** Knob to select 'Review Airspaces' and press the **ENT** Key. The system displays the INFORMATION window.
- 5) Press the **FMS** Knob or the **CLR** Key to remove the INFORMATION window.

Viewing FIS-B Weather Status

- 1) Turn the large **FMS** Knob to select the AUX Page Group.
- 2) Turn the small **FMS** Knob to select the AUX - ADS-B Status Page.

ADS-B Status Page Item	Status Message	Description
FIS-B Weather Status: FIS-B Processing	ENABLED	The FIS-B weather feature is enabled to process and display FIS-B weather products.
	DISABLED	The FIS-B weather feature is disabled.
	-----	No data received from the GDL 88 UAT.
Weather Products: AIRMET CONUS NEXRAD METAR METAR GRAPHICAL	AVAILABLE	FIS-B weather data is available for display for the weather product.
	NOT AVAILABLE	FIS-B weather data is not available for the weather product, and/or the system is not receiving the FIS-B weather service.
NOTAM/TFR PIREP REGIONAL NEXRAD SIGMET TAF WINDS/TEMPS ALOFT	AWAITING DATA	The system is receiving the FIS-B weather service, and is waiting to receive the weather product from the FIS-B data broadcast.

AUX-ADS-B Status Page Messages for FIS-B Weather

AIRBORNE COLOR WEATHER RADAR



WARNING: Begin transmitting only when it is safe to do so. If it is desired to transmit while the aircraft is on the ground, no personnel or objects should be within 11 feet of the antenna.



CAUTION: In Standby Mode, the antenna is parked at the center line. It is always a good idea to put the radar in Standby Mode before taxiing the aircraft to prevent the antenna from bouncing on the bottom stop and possibly causing damage to the radar assembly.

Displaying Weather on the Weather Radar Page

- 1) Turn the large **FMS** Knob to select the Map Page Group.
- 2) Turn the small **FMS** Knob to select the Weather Radar Page.
- 3) Press the **MODE** Softkey.
- 4) If the aircraft is on the ground, press the **STANDBY** Softkey. When a GWX 68 is installed, a one minute warm-up period is initiated. After the warm-up is complete, the radar will enter the Standby Mode. When a GWX 70 is installed, the radar will enter Standby Mode immediately. After the aircraft is airborne, press the **WEATHER** Softkey.

Or:

If the aircraft is already airborne, press the **WEATHER** or **GROUND** Softkey. When a GWX 68 is installed, a one-minute warm-up period will be initiated, after which the radar will begin transmitting. When a GWX 70 is installed, there is no warm-up period and radar begins transmitting immediately. The horizontal scan is initially displayed.

- 5) Turn the **Joystick** to select the desired range.
- 6) If desired, press the **VERTICAL** Softkey for vertical scanning.

Weather Mode Color	Intensity	Approximate Precipitation Rate (in/hr.)
Black	< 23 dBZ	< .01.
Green (GWX 68)	23 dBZ to < 32 dBZ	.01 - 0.1.
Green (GWX 70)	23 dBZ to < 33 dBZ	.01 - 0.1.
Yellow (GWX 68)	32 dBZ to < 41 dBZ	0.1 - 0.5
Yellow (GWX 70)	33 dBZ to < 41 dBZ	0.1 - 0.5
Red (GWX 68)	41 dBZ to < 50 dBZ	0.5 - 2
Red (GWX 70)	41 dBZ and greater	0.5 and greater
Magenta* (GWX 68 only)	50 dBZ and greater	> 2

*Magenta color not applicable to GWX 70 installations

- Flight Instruments
- EIS
- Nav/Com/XPDR/Audio
- AFCS
- GPS Nav
- Flight Planning
- Procedures
- Hazard Avoidance
- Additional Features
- Abnormal Operation
- Annun/Alerts
- Appendix
- Index

Adjusting Antenna Tilt

Move the **Joystick** up or down to adjust the tilt of the antenna up or down. Monitor the displayed tilt value in the TILT field.

When scanning vertically, a Tilt Line may be displayed to aid in positioning the tilt of the antenna. If the Tilt Line is not displayed, perform the following steps:

- 1) Press the **MENU** Key
- 2) Turn the large **FMS** Knob to select 'Show Tilt Line'.
- 3) Press the **ENT** Key.

Adjusting Antenna Bearing

Move the **Joystick** right or left to adjust the azimuth position of the antenna right or left. Monitor the displayed bearing value in the BEARING field.

When scanning horizontally, a Bearing Line may be displayed to aid in positioning the antenna for the vertical scan. If the Bearing Line is not displayed, perform the following steps:

- 1) Press the **MENU** Key
- 2) Turn the large **FMS** Knob to select 'Show Bearing Line'.
- 3) Press the **ENT** Key.

Vertically Scan a Storm Cell

- 1) While in the Horizontal Scan view, move the **Joystick** to place the Bearing Line on the desired storm cell, or other area, to be vertically scanned.
- 2) Press the **VERTICAL** Softkey. A vertical 'slice' of the selected area will now be displayed.
- 3) Move the **Joystick** right or left to move the scanned "slice" a few degrees right or left.
- 4) Turn the **Joystick** to adjust the range.
- 5) To select a new area to be vertically scanned, press the **HORIZON** Softkey to return to the Horizontal Scan view and repeat the previous steps.

Adjusting Gain



WARNING: Changing the gain in Weather Mode will cause precipitation intensity to be displayed as a color not representative of the true intensity. Remember to return the gain setting to 'Calibrated' for viewing the actual intensity of precipitation.

- 1) Press the **GAIN** Softkey to activate the cursor in the 'GAIN' field.
- 2) Turn the small **FMS** Knob to adjust the gain for the desirable level. The gain setting is visible in the gain field as a movable horizontal bar in a flashing box. The line pointer is a reference depicting the calibrated position.
- 3) Press the **FMS** Knob to remove the cursor.
- 4) Press the **GAIN** Softkey again to recalibrate the gain. 'CALIBRATED' will be displayed in the 'GAIN' field.

Ground Mapping

- 1) Press the **MODE** Softkey.
- 2) Press the **GROUND** Softkey to place the radar in Ground Map Mode.
- 3) Press the **BACK** Softkey.
- 4) Press the **FMS** Knob to activate the cursor
- 5) Press the **FMS** Knob to place the cursor in the 'TITL' field
- 6) Adjust the antenna tilt angle by turning the small **FMS** Knob to position the ground returns as desired.
- 7) Press the **FMS** Knob to remove

Ground Map Mode Color	Intensity
Black (GWX 68)	0 dB
Black (GWX 70)	0 dB to 3 dB
Cyan (GWX 68)	> 0 dB to < 9 dB
Cyan (GWX 70)	>3 dB to < 13 dB
Yellow (GWX 68)	9 dB to < 18 dB
Yellow (GWX 70)	13 dB to < 21 dB
Magenta (GWX 68)	18 dB to < 27 dB
Magenta (GWX 70)	21 dB < 29 dB
Blue (GWX 68)	27 dB and greater
Blue (GWX 70)	29 dB and greater

Sector Scan

- 1) While in the Horizontal Scan Mode, move the **Joystick** right or left to place the Bearing Line in the desired position. The location of the Bearing Line will become the center point of the Sector Scan.
- 2) Press the **FMS** Knob to display the cursor.
- 3) Turn the large **FMS** Knob to place the cursor in the SECTOR SCAN field.
- 4) Turn the small **FMS** Knob to select FULL, 60°, 40°, or 20° scan.
- 5) If desired, readjust the Bearing Line with the **Joystick** to change the center of the Sector Scan.
- 6) Press the **FMS** Knob to remove the cursor.

Antenna Stabilization

- 1) To activate or deactivate the antenna stabilization, press the **MODE** Softkey.
- 2) Press the **STAB ON** Softkey to activate antenna stabilization or press the **STAB OFF** Softkey to deactivate. The current stabilization condition is shown in the upper right of the weather radar display.

Weather Attenuated Color Highlight (WATCH[®])

To activate or deactivate the WATCH[®] feature, press the **WATCH** Softkey. This feature is only available in the Horizontal Scan Mode.

Weather Alert





To activate or deactivate Weather Alert, press the **WX ALERT** Softkey. Activating and deactivating will also enable or inhibit the alert on the PFD.

Automatic Standby

When the weather radar system is in the Weather or Ground Map Mode, upon landing the system will automatically switch to Standby Mode.

TRAFFIC SYSTEMS

- If Traffic information Service (TIS) is configured, **STANDBY**, **OPERATE**, and **TNA MUTE** softkeys are displayed.
- If a Traffic Advisory System (TAS) is configured, **MUTE** and **ALT MODE** softkeys are displayed.

Traffic Symbol	Description
	Non-Threat Traffic (intruder is beyond 5 nm and greater than 1200' vertical separation)
	Proximity Advisory (PA) (Not available with TIS system) (intruder is within 5 nm and less than 1200' vertical separation)
	Traffic Advisory (TA) (closing rate, distance, and vertical separation meet TA criteria)
	Traffic Advisory Off Scale

Traffic Symbol Description

Traffic Information Service (TIS)



NOTE: If the G1000 is configured to use an optional Traffic Advisory System (TAS), TIS is not available for use.



NOTE: Traffic Information Service (TIS) is only available when the aircraft is within the service volume of a TIS capable terminal radar site.

Displaying Traffic on the Traffic Map Page

- 1) Turn the large **FMS** Knob to select the Map Page Group.
- 2) Turn the small **FMS** Knob to select the Traffic Map Page.
- 3) Press the **OPERATE** Softkey to begin displaying traffic. 'OPERATING' is displayed in the Traffic Mode field.
- 4) Press the **STANDBY** Softkey to place the system in the Standby Mode. 'STANDBY' is displayed in the Traffic Mode field.
- 5) Rotate the **Joystick** clockwise to display a larger area or rotate counter-clockwise to display a smaller area.
- 6) Press the **TNA MUTE** Softkey to mute the "Traffic Not Available" aural alert.

Displaying Traffic on the Navigation Map

- 1) Ensure TIS is operating. With the Navigation Map displayed, press the **MAP** Softkey.
- 2) Press the **TRAFFIC** Softkey. Traffic is now displayed on the map.

Traffic Advisory System (TAS) (Optional)

Displaying Traffic on the Traffic Map Page

- 1) Turn the large **FMS** Knob to select the Map Page Group.
- 2) Turn the small **FMS** Knob to select the Traffic Map Page. 'OPERATING' is displayed in the Traffic Mode field.
- 3) Press the **ALT MODE** Softkey to change the altitude volume. Select the desired altitude volume by pressing the **BELOW**, **NORMAL**, **ABOVE**, or **UNREST** (unrestricted) Softkey. The selection is displayed in the Altitude Mode field.
- 4) Rotate the **Joystick** clockwise to display a larger area or rotate counter-clockwise to display a smaller area.
- 5) Press the **MUTE** Softkey to mute TAS voice alerts.

Displaying Traffic on the Navigation Map

- 1) Ensure TAS is operating.
- 2) With the Navigation Map displayed, press the **MAP** Softkey.
- 3) Press the **TRAFFIC** Softkey. Traffic is now displayed on the map.

GDL 88 ADS-B TRAFFIC (OPTIONAL)

The optional Garmin GDL 88 is a dual-link Universal Access Transceiver (UAT). It sends and receives Automatic Dependent Surveillance-Broadcast (ADS-B) traffic information on the 978 MHz UAT frequency. The system provides visual annunciations and voice traffic alerts to help the pilot visually acquire potentially conflicting traffic.

Enabling/Disabling the Display of ADS-B Traffic

- 1) Select the Traffic Map Page.
- 2) Press the **ADS-B** Softkey.

Testing ADS-B Traffic

- 1) Select the Traffic Map Page.
- 2) If necessary, turn the Joystick to select a map range of 2 and 6 nm to ensure full test pattern display.
- 2) Ensure the **ADS-B** Softkey is disabled.
- 3) If the optional TAS/TCAS I is installed, ensure the **TAS STBY** Softkey is enabled.

- 4) Press the **Test** Softkey.

Enabling/Disabling the Display of Flight IDs

- 1) Select the Traffic Map Page.
- 2) Press the **FLT ID** Softkey to enable/disable the display of Flight IDs.

Changing the Altitude Range

- 1) On the Traffic Map Page, select the **ALT MODE** Softkey.
- 2) Press one of the following Softkeys:
 - **ABOVE:** Displays non-threat and proximity traffic from 9000 feet above the aircraft to 2700 feet below the aircraft. Typically used during climb phase of flight.
 - **NORMAL:** Displays non-threat and proximity traffic from 2700 feet above the aircraft to 2700 feet below the aircraft. Typically used during enroute phase of flight.
 - **BELOW:** Displays non-threat and proximity traffic from 2700 feet above the aircraft to 9000 feet below the aircraft. Typically used during descent phase of flight.
 - **UNREST** (unrestricted): All traffic is displayed from 9900 feet above and 9900 feet below the aircraft.
- 3) To return to the Traffic Map Page, press the **BACK** Softkey.

Enabling/Disabling the Motion Vector Display

- 1) Select the Traffic Map Page.
- 2) Press the **MOTION** Softkey.
- 3) Press one of the following softkeys:
 - **ABS:** Displays the motion vector pointing in the absolute direction.
 - **REL:** Displays the motion vector relative to own aircraft
 - **OFF:** Disables the display of the motion vector.

Adjusting the Duration for the Motion Vector Projected Time

- 1) Select the Traffic Map Page.
- 2) Press the **MOTION** Softkey.
- 3) Press the **DURATION** Softkey.
- 4) Press a softkey for the desired duration (**30 SEC, 1 MIN, 2 MIN, 5 MIN**).

- When finished, press the **BACK** Softkey to return to the Traffic Map Page.

Showing Additional Traffic Information

- Select the Traffic Map Page.
- Press the **FMS** Knob. A cyan bracket highlights the first selected traffic symbol. Additional information appears in a window in the upper-right corner of the Traffic Map Page.
- To select a different aircraft symbol, turn the **FMS** Knob to move the cyan bracket until the selected aircraft traffic symbol is highlighted.
- When finished, press the **FMS** Knob again to remove the cyan selection bracket.

Viewing ADS-B Traffic Status

- Turn the large **FMS** Knob to select the AUX Page Group.
- Turn the small **FMS** Knob to select the AUX - ADS-B Status Page.

ADS-B Status Page Item	Status Message	Description
Traffic Application Status: AIRBORNE (AIRB), SURFACE (SURF), AIRBORNE ALERTS (CSA)	ON	Traffic application is currently on. Required input data is available, and it meets performance requirements.
	AVAILABLE TO RUN	Traffic application is not currently active, but application is ready to run when condition(s) determine the application should be active. Required input data is available, and it meets performance requirements.
	NOT AVAILABLE	Traffic application is not available. Required input data is available, but it does not meet performance requirements.
	FAULT	Traffic application is not available. Required input data is not available or the application has failed.
	NOT CONFIGURED	Traffic application is not available, because it has not been configured. If this annunciation persists, the system should be serviced.
	-----	Traffic application status is invalid or unknown.

ADS-B Status Page Item	Status Message	Description
TIS-B/ADS-R Coverage	AVAILABLE	The system is receiving the ADS-R coverage from an FAA ground station.
	NOT AVAILABLE	The system is not receiving the ADS-R coverage from an FAA ground station.
	-----	ADS-R coverage is invalid or unknown.
GPS Status: GPS Source	External #1	The GDL 88 is using the #1 GPS receiver for the GPS position source.
	External #2	The GDL 88 is using the #2 GPS receiver for the GPS position source.
	-----	The GPS source is invalid or unknown.
Ground Uplink Status: Last uplink	Number of minutes, or '-----'	Displays the number of minutes since the last uplink from a ground station occurred. If no uplink has been received, or the status is invalid, dashes appear instead of a number of minutes.

AUX-ADS-B Status Page Messages for ADS-B Traffic

TERRAIN AND OBSTACLE PROXIMITY



NOTE: Terrain data is not displayed when the aircraft latitude is greater than 75 degrees north or 60 degrees south.

Displaying Terrain and Obstacles on the Terrain Proximity Page

- 1) Turn the large **FMS** Knob to select the Map Page Group.
- 2) Turn the small **FMS** Knob to select the last rectangular page icon.
- 3) If desired, press the **VIEW** Softkey to access the **ARC** and **360** Softkeys. When the **ARC** Softkey is pressed, a radar-like 120° view is displayed. Press the **360** Softkey to return to the 360° default display.
- 4) Rotate the **Joystick** clockwise to display a larger area or rotate counter-clockwise to display a smaller area.

Color	Terrain/Obstacle Location
Red	Terrain/Obstacle above or within 100' below current aircraft altitude.
Yellow	Terrain/Obstacle between 100' and 1000' below current aircraft altitude.
Gray	Terrain/Obstacle is more than 1000' below aircraft altitude.

Displaying Terrain and Obstacles on the Navigation Map

- 1) With the Navigation Map displayed, press the **MAP** Softkey.
- 2) Press the **TERRAIN** Softkey. Terrain and obstacle proximity will now be displayed on the map.

TERRAIN-SVS



NOTE: Terrain-SVS is only available when Synthetic Vision Technology (SVT) option is installed.



NOTE: Terrain data is not displayed when the aircraft latitude is greater than 75 degrees north or 60 degrees south.

Display Terrain on the Terrain-SVS Page

- 1) Turn the large **FMS** Knob to select the Map Page Group.
- 2) Turn the small **FMS** Knob to select the Terrain-SVS Page.
- 3) If desired, press the **VIEW** Softkey to access the **ARC** and **360** softkeys. When the **ARC** Softkey is selected, a radar-like 120° view is displayed. Press the **360** Softkey to return to the 360° default display.
- 4) Rotate the **Joystick** clockwise to display a larger area or rotate counter-clockwise to display a smaller area.

Color	Terrain/Obstacle Location
Red	Terrain/Obstacle above or within 100' below current aircraft altitude.
Yellow	Terrain/Obstacle between 100' and 1000' below current aircraft altitude.
Gray	Terrain/Obstacle is more than 1000' below aircraft altitude.

Enable/Disable Aviation Data

- 1) While the Terrain-SVS Page is displayed, press the **MENU** Key.
- 2) Turn the small **FMS** Knob to select "Show (or Hide) Aviation Data".
- 3) Press the **ENT** Key.

Terrain-SVS Inhibit

Inhibit Terrain

While the Terrain-SVS Page is displayed, press the **INHIBIT** Softkey.

Or:

- 1) Press the **MENU** Key.
- 2) Turn the small **FMS** Knob to select 'Inhibit Terrain'.
- 3) Press the **ENT** Key.

Enable Terrain

While the Terrain-SVS Page is displayed, press the **INHIBIT** Softkey.

Or:

- 1) While the Terrain-SVS Page is displayed, press the **MENU** Key.
- 2) Turn the small **FMS** Knob to select 'Enable Terrain'.
- 3) Press the **ENT** Key.

ADDITIONAL FEATURES

SYNTHETIC VISION (OPTIONAL)



WARNING: Use appropriate primary systems for navigation, and for terrain, obstacle, and traffic avoidance. SVT is intended as an aid to situational awareness only and may not provide either the accuracy or reliability upon which to solely base decisions and/or plan maneuvers to avoid terrain, obstacles, or traffic.



WARNING: Do not use SVT runway depiction as the sole means for determining the proximity of the aircraft to the runway or for maintaining the proper approach path angle during landing.

Synthetic Vision Technology (SVT) functionality is offered as an optional enhancement to the G1000 Integrated Flight Deck System.

SVT is primarily comprised of a computer-generated forward-looking, attitude aligned view of the topography immediately in front of the aircraft from the pilot's perspective. SVT information is shown on the primary flight display (PFD).

SVT offers a three-dimensional view of terrain and obstacles. Terrain and obstacles that pose a threat to the aircraft in flight are shaded yellow or red.

In addition to SVT enhancement to the PFD, the following feature enhancements have been added to the PFD:

- Pathways
- Flight Path Marker
- Horizon Heading Marks
- Traffic Display
- Terrain and Obstacle Alerting
- Airport Signs
- Runway Display

Activating and deactivating SVT

- 1) Press the **PFD** Softkey.
- 2) Press the **SYN VIS** Softkey.
- 3) Press the **SYN TERR** Softkey. The SVT display will cycle on or off with the **SYN TERR** Softkey.

Activating and deactivating Pathways

- 1) Press the **PFD** Softkey.
- 2) Press the **SYN VIS** Softkey.
- 3) Press the **PATHWAY** Softkey. The Pathway feature will cycle on or off with the **PATHWAY** Softkey.

Activating and deactivating Horizon Headings

- 1) Press the **PFD** Softkey.
- 2) Press the **SYN VIS** Softkey.
- 3) Press the **HRZN HDG** Softkey. The horizon heading display will cycle on or off with the **HRZN HDG** Softkey.

Activating and deactivating Airport Signs

- 1) Press the **PFD** Softkey.
- 2) Press the **SYN VIS** Softkey.
- 3) Press the **APTSIGNS** Softkey. Display of airport signs will cycle on or off with the **APTSIGNS** Softkey.

TERMINAL PROCEDURE CHARTS



NOTE: Regardless of the availability of SafeTaxi[®], ChartView, or FliteCharts[®], it may be necessary to carry another source of charts on-board the aircraft.

SafeTaxi[®]

SafeTaxi[®] is an optional feature that gives greater map detail as the map range is adjusted in on the airport. The airport display on the map reveals runways with numbers, taxiways identifiers, and airport landmarks including ramps, buildings, control towers, and other prominent features. Resolution is greater at lower map ranges. The aircraft symbol provides situational awareness while taxiing.

Pressing the **DCLTR** Softkey (declutter) once removes the taxiway markings and airport identification labels. Pressing the **DCLTR** Softkey twice removes VOR station ID, the VOR symbol, and intersection names if within the airport plan view. Pressing the **DCLTR** Softkey a third time removes the airport runway layout, unless the airport in view is part of an active route structure. Pressing the **DCLTR** Softkey again cycles back to the original map detail.

The SafeTaxi database contains detailed airport diagrams for selected airports. These diagrams provide the pilot with situational awareness by displaying the aircraft position in relation to taxiways, ramps, runways, terminals, and services. This information should not be used by the pilot as the basis for maneuvering the aircraft on the ground. This database is updated on a 56-day cycle.

ChartView (Optional)

ChartView resembles the paper version of Jeppesen terminal procedures charts. The charts are displayed in full color with high-resolution. The MFD depiction shows the aircraft position on the moving map in the plan view of most approach charts and on airport diagrams.

The ChartView database is updated on a 14-day cycle. If the ChartView database is not updated within 70 days of the expiration date, ChartView will no longer function.

FliteCharts® (Optional)

FliteCharts® resemble the paper version of AeroNav Services terminal procedures charts. The charts are displayed with high-resolution and in color for applicable charts. The selected Display Pane depiction shows the aircraft position on the moving map in the plan view of most approach charts and on airport diagrams.

The FliteCharts database contains procedure charts for the United States only. This database is updated on a 28-day cycle. If not updated within 180 days of the expiration date, FliteCharts will no longer function.

View Charts from the Navigation Map Page

- 1) Press the **SHW CHRT** Softkey when displayed.

Or:

Move the map pointer to point to a desired point on the map and press the **SHW CHRT** Softkey.

- 2) Press the **DP, STAR, APR, WX,** and **NOTAM** softkeys to access charts for departures, arrivals, approaches, weather and NOTAMS. Note that NOTAMS are only available with ChartView.
- 3) Press the **GO BACK** Softkey to return to the previous page.

View Charts from the Active Flight Plan Page

- 1) While viewing the Active Flight Plan Page, press the **FMS** Knob to activate the cursor.

- 2) Turn the large **FMS** Knob to select the departure airport, destination airport, departure, arrival, or approach.
- 3) Press the **SHW CHRT** Softkey. The appropriate chart is displayed, if available for the item selected.
- 4) Press the **GO BACK** Softkey to return to the previous page.

Change Day/Night View

- 1) While viewing a chart press the **MENU** Key to display the Page Menu OPTIONS.
- 2) Turn the large **FMS** Knob to highlight the 'Chart Setup' Menu Option and press the **ENT** Key.
- 3) Turn the large **FMS** Knob to move between the 'FULL SCREEN' and 'COLOR SCHEME' Options.
- 4) Turn the small **FMS** Knob to choose between the 'On' and 'Off' Full Screen Options.
- 5) Turn the small **FMS** Knob to choose between 'Day', 'Auto', and 'Night' Options.
- 6) In Auto Mode, turn the large **FMS** Knob to select the percentage field and change percentage with the small **FMS** Knob. The percentage of change is the day/night crossover point based on backlighting intensity.
- 7) Press the **FMS** Knob when finished to remove the Chart Setup Menu.

AIRPORT DIRECTORY

The AOPA or optional AC-U-KWIK[®] Airport Directory adds enhanced airport information when viewing airports on the WPT-Airport Information Page.

The Airport Directory databases are revised every 56 days and offered on a subscription basis. Check fly.garmin.com for the current database.

View Airport Directory Information

While viewing the WPT-Airport Information Page, if necessary, press the **INFO-1** Softkey to change the softkey label to display **INFO-2**. Airport Directory information is displayed on the right half of the display.

SIRIUSXM SATELLITE RADIO ENTERTAINMENT (OPTIONAL)

The XM[®] Radio Page provides information and control of the audio entertainment features of the SiriusXM Satellite Radio.

Selecting the XM Radio Page

- 1) Turn the large **FMS** Knob to select the Auxiliary Page Group.
- 2) Turn the small **FMS** Knob to select the displayed AUX - XM Information Page.
- 3) Press the **RADIO** Softkey to show the XM Radio Page where audio entertainment is controlled.

Active Channel and Channel List

The Active Channel Box on the XM Radio Page displays the currently selected channel. The Channels List Box of the XM Radio Page shows a list of the available channels for the selected category.

Selecting a Category

The Category Box of the XM Radio Page displays the currently selected category of audio.

- 1) Press the **CATGRY** Softkey on the XM Radio Page.
- 2) Press the **CAT +** and **CAT -** Softkeys to cycle through the categories.

Or:

Turn the small **FMS** Knob to display the 'Categories' list. Highlight the desired category with the small **FMS** Knob.

- 3) Press the **ENT** Key.

Select an Available Channel within the Selected Category

- 1) While on the XM Radio Page, press the **CHNL** Softkey.
- 2) Press the **CH +** Softkey to go up through the list in the Channel Box, or move down the list with the **CH -** Softkey.

Or:

Press the **FMS** Knob to highlight the channel list and turn the large **FMS** Knob to scroll through the channels.

- 3) With the desired channel highlighted, press the **ENT** Key.

Entering a Channel Directly

- 1) While on the XM Radio Page, press the **CHNL** Softkey.

- 2) Press the **DIR CH** Softkey. The channel number in the Active Channel Box is highlighted.
- 3) Press the numbered softkeys located on the bottom of the display to directly select the desired channel number.
- 4) Press the **ENT** Key to activate the selected channel.

Assigning Channel Presets

Up to 15 channels from any category can be assigned a preset number.

- 1) On the XM Radio Page, with the desired channel active, press the **PRESETS** Softkey to access the first five preset channels (**PS1 - PS5**).
- 2) Press the **MORE** Softkey to access the next five channels (**PS6 – PS10**), and again to access the last five channels (**PS11 – PS15**). Pressing the **MORE** Softkey repeatedly cycles through the preset channels.
- 3) Press any one of the (**PS1 - PS15**) softkeys to assign a number to the active channel.
- 4) Press the **SET** Softkey on the desired channel number to save the channel as a preset.

Adjusting Volume

- 1) On the XM Radio Page, press the **RADIO** Softkey.
- 2) Press the **VOL** Softkey to access the volume control softkeys.
- 3) Press **VOL +** or **VOL -** softkeys to adjust the volume level.
- 4) Press the **MUTE** Softkey to mute the radio audio.

SATELLITE TELEPHONE & SMS MESSAGING SERVICE (OPTIONAL)

Operation of these features in the cockpit is accomplished through the AUX-TELEPHONE, and the AUX-TEXT MESSAGING SETUP Pages.



NOTE: *Aural and pop-up visual annunciations for incoming calls and received text messages are inhibited during taxiing, takeoff and landing roll, low altitude operations, low airspeed operations, and excessive pitch and roll attitudes.*

Registering With Garmin Connex

A subscriber account must be established prior to using the Iridium Satellite System. Before setting up an Iridium account, obtain the serial number of the Iridium Transceiver and the System ID by viewing the AUX- SYSTEM STATUS Page. Contact Garmin Connex at 1-866-739-5687 in the United States or 913-397-8200, ext. 1135.

Disable/Enable Iridium Transceiver

Iridium telephone may be turned on or off by performing the following steps.

To enable the Iridium telephone system:

- 1) With the AUX-TELEPHONE Page displayed, select the **MENU** Key on the MFD to display the Page Menu.
- 2) Turn either **FMS** Knob to place the cursor on 'Enable Iridium Transmission'.
- 3) Press the **ENT** Key.

To disable the Iridium telephone system:

- 1) With the AUX-TELEPHONE Page displayed, select the **MENU** Key on the MFD to display the Page Menu.
- 2) Turn either **FMS** Knob to place the cursor on 'Disable Iridium Transmission'.
- 3) Press the **ENT** Key.



Telephone Communication

The pilot or copilot can place and answer calls on the Iridium satellite network. Control and monitoring of telephone functions are accomplished through the AUX-TELEPHONE Page.

To view the Telephone Page:

- 1) Turn the large **FMS** Knob on the MFD to select the AUX page group.
- 2) Turn the small **FMS** Knob to select SATELLITE PHONE.

Internal Phone	External Phone	Description
		Phone is Idle
		Phone is ringing
		Phone has a dial tone (off hook) or connected to another phone
		Phone dialed is busy
		Phone is dialing another phone
		Phone has failed
		Phone status not known
		Phone is disabled
		Phone is reserved for data transmission
		Calling other phone or incoming call from other phone

Internal Phone	External Phone	Description
		Other phone is on hold
		Phones are connected

Incoming Calls

When viewing MFD pages other than the AUX-TELEPHONE Page, a pop-up alert will be displayed. The pop-up alert may be inhibited at times, such as during takeoff. In addition to the pop-up alert, a ringing phone symbol will be displayed to the right of the MFD page title. Also, the voice alert “Incoming Call” will be heard on the selected cockpit audio.



NOTE: The Push-to-Talk switch is not utilized for telephone communication. The microphone is active after selecting the **ANSWER** Softkey, and stays active until the call is terminated.

Answering an incoming call:

- 1) Press the **TEL** Key on the audio panel.
- 2) Select the **ANSWER** Softkey on the MFD.

Or:

While viewing the AUX-TELEPHONE Page:

- 1) Press the **TEL** Key on the audio panel.
- 2) Press the **MENU** Key to display the Page Menu.
- 3) Turn either **FMS** Knob to place the cursor on ‘Answer Incoming Call’.
- 4) Press the **ENT** Key.

Selecting the **IGNORE** Softkey will extinguish the pop-up window and leave the current call unanswered. Selecting the **IGNRE ALL** Softkey will extinguish the pop-up window for the current and all future incoming calls and leave the current call unanswered. Selecting the **TEL** Softkey will display the AUX-TELEPHONE Page allowing additional call information to be viewed before answering.

Disabling incoming call alerts:

- 1) With the AUX-TELEPHONE Page displayed, press the **MENU** Key on the MFD to display the Page Menu.
- 2) Turn either **FMS** Knob to place the cursor on 'Disable Incoming Call Alerts'.
- 3) Press the **ENT** Key. The voice and pop-up alert will not be displayed now when an incoming call is received.

Outgoing Calls

Voice calls can be made from the cockpit through the Iridium Satellite Network.

To make a call:

- 1) Press the **TEL** Key on the appropriate audio panel.
- 2) Select the **DIAL** Softkey on the MFD.
- 3) Turn the small **FMS** Knob to select 'IRIDIUM'.
- 4) Press the **ENT** Key. The cursor has now moved to the phone number entry field.
- 5) Enter the desired telephone number by selecting the number softkeys on the MFD or by pressing the numeric keys on the MFD Control Unit. The International dialing sequence is necessary to place a call from the cockpit to an external phone: Country Code + City/Area Code (if any) + Telephone Number.

The following country codes may be used when calling other satellite telephone systems.

Satellite System	Country Code
Inmarsat	870
ICO	8810 or 8811
Ellipso	8812 or 8813
Iridium	8816 or 8817
Globalstar	8818 or 8819

- 6) Press the **ENT** Key. 'OK' is highlighted.
- 7) Press the **ENT** Key. The system will begin calling the number.

To exit the call, press the **HANGUP** Softkey.







Text Messaging (SMS)

Messages may be sent to an email address or text message capable cellular telephone. Message length is limited to 160 characters, including the email address.

The text messaging user interface is mainly through the AUX-TEXT MESSAGING Page.

Viewing the Text Messaging Page

- 1) Turn the large **FMS** Knob on the MFD to select the AUX page group.
- 2) Turn the small **FMS** Knob to select SATELLITE PHONE.
- 3) If necessary, press the **SMS** Softkey to display the AUX-TEXT MESSAGING Page.

Message Symbol	Description
	Received text message that has not been opened
	Received text message that has been opened
	Saved text message, draft not sent
	System is sending text message
	Text message has been sent
	System failed to send text message
	Predefined text message

Viewing a Text Message When Received

When viewing MFD pages other than the AUX-TEXT MESSAGING Page, a pop-up alert will be displayed when a new text message is received.

Press the **VIEW** Softkey to view the message. Pressing the **IGNORE** Softkey will extinguish the pop-up window and leave the text message unopened. Pressing the **IGNR ALL** Softkey will extinguish the pop-window and ignore all future incoming text messages. Pressing the **SMS** Softkey will display the AUX-TEXT MESSAGING Page.

The pop-up alerts may be enabled or disabled through the Page Menu.

Enable/Disable Incoming Text Message Pop-Up Alerts

- 1) With the AUX-TEXT MESSAGING Page displayed, press the **MENU** Key on the MFD to display the Page Menu.
- 2) Turn either **FMS** Knob to place the cursor on 'Disable New Message Popups' or 'Enable New Message Popups'.
- 3) Press the **ENT** Key. The pop-up alert will not be displayed when an incoming text message is received.

Reply to a Text Message

While viewing the text message, press the **REPLY** Softkey.

Or:

- a) Press the **MENU** Key to display the Page Menu.
- b) Turn either **FMS** Knob to place the cursor on 'Reply To Message'.
- c) Press the **ENT** Key.

Sending a Text Message

- 1) While viewing the AUX-TEXT MESSAGING Page, press the **NEW** Softkey.
Or:
 - a) Press the **MENU** Key to display the Page Menu.
 - b) Turn either **FMS** Knob to place the cursor on 'Draft New Message'.
 - c) Press the **ENT** Key.
- 2) The TEXT MESSAGE DRAFT Window is now displayed with the cursor in the 'TO' field. Enter the desired telephone number or email address. Entry can be accomplished through the alphanumeric keys on the PFD/MFD Control Unit, or combination of the **FMS** Knob on the controller and softkeys on the MFD. The **FMS** Knob is used to enter letters and numbers, or numbers can be entered from the MFD by pressing the **NUMBERS** Softkey. Press the **CAP LOCK** Softkey to create upper and lower case alpha characters. Special characters can be accessed by pressing the **SYMBOLS** Softkey.

- 3) Press the **ENT** Key. The cursor is now displayed in the 'MESSAGE' field.
- 4) Enter the desired message using any combination of entry methods as described in step 2.
- 5) Press the **ENT** Key.
- 6) Press the **SEND** Softkey to send the message immediately, or press the **SAVE** Softkey to save the message in Outbox for sending at a later time. Press the **CANCEL** Softkey to delete the message.

Predefined Text Messages

Time and effort can be saved in typing text messages that are used repeatedly by saving these messages as a predefined message.

Create a Predefined Text Message

- 1) While viewing the AUX-TEXT MESSAGING Page, press the **MENU** Key to display the Page Menu.
- 2) Turn either **FMS** Knob to select 'Edit Predefined Messages'.
- 3) Press the **ENT** Key. The PREDEFINED MESSAGES view is now displayed.
- 4) Press the **NEW** Softkey.

Or:

 - a) Press the **MENU** Key to display the Page Menu.
 - b) Turn either **FMS** Knob to place the cursor on 'Draft New Predefined Message'.
 - c) Press the **ENT** Key. The PREDEFINED SMS TEXT MESSAGE Window is now displayed.
- 5) The cursor is displayed in the 'TITLE' field. Enter the desired message title. Entry can be accomplished through the alphanumeric keys on the PFD/MFD Control Unit, or combination of the **FMS** Knob on the controller and softkeys on the MFD. The **FMS** Knob is used to enter letters and numbers, or numbers can be entered from the MFD by pressing the **NUMBERS** Softkey. Press the **CAP LOCK** Softkey to create upper and lower case alpha characters. Special characters can be accessed by pressing the **SYMBOLS** Softkey.
- 6) Press the **ENT** Key. The cursor is now displayed in the 'MESSAGE' field.
- 7) Enter the desired message using any combination of entry methods as described in step 5.
- 8) Press the **ENT** Key.

- 9) Press the **SAVE** Softkey. The new predefined message is now shown in the displayed list. Pressing the **CANCEL** Softkey will delete the message without saving.
- 10) Press the **MENU** Key to display the Page Menu.
- 11) Turn either **FMS** Knob to place the cursor on 'Stop Editing Predefined Message'.
- 12) Press the **ENT** Key.

Send a Predefined Text Message

- 1) While viewing the AUX-TEXT MESSAGING Page, press the **NEW** Softkey.
- 2) The TEXT MESSAGE DRAFT Window is now displayed with the cursor in the 'TO' field. Enter the desired telephone number or email address. Entry can be accomplished through the alphanumeric keys on the PFD/MFD Control Unit, or combination of the **FMS** Knob on the controller and softkeys on the MFD. The **FMS** Knob is used to enter letters and numbers, or numbers can be entered from the MFD by pressing the **NUMBERS** Softkey. Press the **CAP LOCK** Softkey to create upper and lower case alpha characters. Special characters can be accessed by pressing the **SYMBOLS** Softkey.
- 3) Press the **ENT** Key. The cursor is now displayed in the 'MESSAGE' field.
- 4) Press the **PREDEFD** Softkey. The PREDEFINED MESSAGE MENU Window is displayed.
- 6) Press the **ENT** Key. The predefined message text is inserted into the message field. If desired, the message can be edited by using the FMS Knobs.
- 7) Press the **ENT** Key.
- 8) Press the **SEND** Softkey to transmit the message.

Text Message Boxes

Received text messages reside in the Inbox as 'Read' or 'Unread' messages. The Outbox contains 'Sent' and 'Unsent' text messages. Saved messages that are meant to be sent later are stored as Drafts. Each text message box may be viewed separately, or together in any combination.

Show Inbox Messages

While viewing the AUX-TEXT MESSAGING Page, press the **ARRANGE**

Softkey, then press the **INBOX** Softkey.

Or:

- a) Press the **MENU** Key to display the Page Menu.
- b) Turn either **FMS** Knob to place the cursor on 'Show Inbox Messages'.
- c) Press the **ENT** Key. The message box selected for viewing is indicated at the bottom left of the list window.

Show Outbox Messages

While viewing the AUX-TEXT MESSAGING Page, press the **ARRANGE** Softkey, then press the **OUTBOX** Softkey.

Or:

- a) Press the **MENU** Key to display the Page Menu.
- b) Turn either **FMS** Knob to place the cursor on 'Show Outbox Messages'.
- c) Press the **ENT** Key. The message box selected for viewing is indicated at the bottom left of the list window.

Show Draft Messages

While viewing the AUX-TEXT MESSAGING Page, press the **ARRANGE** Softkey, then press the **DRAFTS** Softkey.

Or:

- a) Press the **MENU** Key to display the Page Menu.
- b) Turn either **FMS** Knob to place the cursor on 'Show Draft Messages'.
- c) Press the **ENT** Key. The message box selected for viewing is indicated at the bottom left of the list window.

Arranging Text Messages

The viewed messages may be listed according to the date/time the message was sent or received, the type of message (read, unread, sent, unsent, etc.), or by message address.

View Messages Sorted by Message Date/Time:

While viewing the AUX-TEXT MESSAGING Page, press the **ARRANGE** Softkey, then press the **TIME** Softkey.

Or:

- a) Press the **MENU** Key to display the Page Menu.
- b) Turn either **FMS** Knob to place the cursor on 'Sort By Date/Time'.
- c) Press the **ENT** Key. The sorting selection is indicated at the bottom center of the list window.

View Messages Sorted by Message Type

While viewing the AUX-TEXT MESSAGING Page, press the **ARRANGE** Softkey, then press the **TYPE** Softkey.

Or:

- a) Press the **MENU** Key to display the Page Menu.
- b) Turn either **FMS** Knob to place the cursor on 'Sort By Type'.
- c) Press the **ENT** Key. The sorting selection is indicated at the bottom center of the list window.

View Messages Sorted by Address:

While viewing the AUX-TEXT MESSAGING Page, press the **ARRANGE** Softkey, then press the **ADDRESS** Softkey.

Or:

- a) Press the **MENU** Key to display the Page Menu.
- b) Turn either **FMS** Knob to place the cursor on 'Sort By Address'.
- c) Press the **ENT** Key. The sorting selection is indicated at the bottom center of the list window.

Viewing The Content of a Text Message

- 1) While viewing the AUX-TEXT MESSAGING Page, select the desired message box.
- 2) Press the **FMS** Knob to activate the cursor.
- 3) Turn either **FMS** Knob to select the desired message.
- 4) Press the **VIEW** Softkey.

Or:

Press the **ENT** Key.

Or:

- a) Press the **MENU** Key to display the Page Menu.
- b) Turn either **FMS** Knob to place the cursor on 'View Selected Message'.
- c) Press the **ENT** Key.

- Flight Instruments
- EIS
- Nav/Com/XPDR/Audio
- AFC
- GPS Nav
- Flight Planning
- Procedures
- Hazard Avoidance
- Additional Features
- Abnormal Operation
- Annun/Alerts
- Appendix
- Index

- 5) To close the text message, press the **CLOSE** Softkey.
- Or:**
- a) Press the **MENU** Key to display the Page Menu.
 - b) Turn either **FMS** Knob to place the cursor on 'Close Message'.
 - c) Press the **ENT** Key.

Mark Selected Message As Read

- 1) While viewing the Inbox on the AUX-TEXT MESSAGING Page, press the **FMS** Knob to activate the cursor.
 - 2) Turn either **FMS** Knob to select the desired message.
 - 3) Press the **MRK READ** Softkey.
- Or:**
- a) Press the **MENU** Key to display the Page Menu.
 - b) Turn either **FMS** Knob to place the cursor on 'Mark Selected Message As Read'.
 - c) Press the **ENT** Key.

The message symbol now indicates the message has been opened.

Mark All Messages As Read

- 1) While viewing the Inbox on the AUX-TEXT MESSAGING Page, press the **MENU** Key to display the Page Menu.
- 2) Turn either **FMS** Knob to place the cursor on 'Mark All New Messages As Read'.
- 3) Press the **ENT** Key. A confirmation window is displayed.
- 4) With cursor highlighting 'YES', press the **ENT** Key. The message symbols now indicate all the message have been opened.

Delete a Message

- 1) While viewing the Inbox on the AUX-TEXT MESSAGING Page, press the **FMS** Knob to activate the cursor.
 - 2) Turn either **FMS** Knob to select the desired message.
 - 3) Press the **DELETE** Softkey.
- Or:**

- a) Press the **MENU** Key to display the Page Menu.
- b) Turn either **FMS** Knob to place the cursor on 'Delete Selected Message'.
- c) Press the **ENT** Key.

ELECTRONIC STABILITY AND PROTECTION (GARMIN ESP™) (OPTIONAL)



NOTE: Refer to the *Airplane Flight Manual* to determine approval of Garmin ESP functionality.

The pilot can interrupt ESP by pressing and holding the Autopilot Disconnect (**AP DISC**) switch. Upon releasing the or **AP DISC** switch, ESP force will again be applied, provided aircraft roll attitude is within engagement limits. ESP can also be overridden by overpowering the servo's mechanical torque limit.

ESP can be enabled or disabled on the AUX-SYSTEM SETUP 2 Page on the MFD.

To enable or disable ESP:

- 1) Turn the large **FMS** Knob to select the AUX Page Group.
- 2) Turn the small **FMS** Knob to select the System Setup Page.
- 3) If necessary, select the **SETUP 2** Softkey to display the AUX-SYSTEM SETUP 2 Page. If the AUX-SYSTEM SETUP 2 is already displayed, proceed to step 4.
- 4) Press the **FMS** Knob to activate the cursor.
- 5) Turn the large **FMS** Knob to place the cursor in the STABILITY & PROTECTION field.
- 6) Turn the small **FMS** Knob to select 'ENABLE' or 'DISABLE'.
- 7) Press the **FMS** Knob to remove the cursor.

ESP is automatically enabled on system power up.

Roll Engagement

Roll Limit Indicators are displayed on the roll scale at 45° right and left, indicating where ESP will engage. As roll attitude exceeds 45°, ESP will engage and the on-side Roll Limit Indicator will move to 30°. The Roll Limit Indicator is now showing where ESP will disengage as roll attitude decreases to within the desirable roll attitude range.

Once engaged, ESP force will be applied between 30° and 75°. The force increases as roll attitude increases and decreases as roll attitude decreases. The applied force is intended to encourage pilot input that returns the airplane to a more normal roll attitude. As roll attitude decreases, ESP will disengage at 30°.

Pitch Engagement

ESP engages at 16° nose-up and 22° nose-down. Once ESP is engaged, it will apply increasing opposing force between 16° and 20° nose-up and between 22° and 25° nose-down. Maximum opposing force is applied between 20° and 50° nose-up and between 25° and 50° nose-down. ESP disengages when 50° is exceeded in a nose-up or nose-down attitude.

With ESP engaged, and the aircraft in a nose-up condition, opposing force steadily decreases from 20° nose-up to 12° nose-up as aircraft pitch moves toward zero degrees. ESP disengages at 12° nose-up. With ESP engaged, and the aircraft in a nose-down condition, opposing force steadily decreases from 25° nose-down to 17° nose-down as aircraft pitch moves toward zero degrees. ESP disengages at 17° nose-down.

The opposing force increases or decreases depending on the pitch angle and the direction of pitch travel. This force is intended to encourage movement in the pitch axis in the direction of the normal pitch attitude range for the aircraft.

There are no indications marking the pitch ESP engage and disengage limits in these nose-up/nose-down conditions.

High Airspeed Protection

Exceeding Vne will result in ESP applying force to raise the nose of the aircraft. When the high airspeed condition is remedied, ESP force is no longer applied.

AUXILIARY VIDEO (OPTIONAL)



NOTE: Images provided on the Aux-Video page are for supplemental use only.

There are four modes of operation of the optional auxiliary video display: Full-Screen, Full-Screen with Digital Zoom, Split-Screen with Map, and Split-Screen with Map and Digital Zoom.

Displaying auxiliary video:

- 1) Turn the large **FMS** Knob to select the AUX page group.
- 2) Turn the small **FMS** Knob to select VIDEO and display the AUX-VIDEO Page.

The video display softkeys shown below appear on the AUX - VIDEO Page. Control of the AUX - VIDEO Page can also be accessed through the Page Menu.

Selecting video menu options:

- 1) While viewing the AUX - VIDEO Page press the **MENU** Key to display the Page Menu OPTIONS.

- 2) Turn the large **FMS** Knob to highlight the desired video adjustment option and press the **ENT** Key.

When the **ENT** key is pressed on any option, the page menu closes and returns to the AUX - VIDEO Page.

Video Setup

Video brightness, contrast, and saturation may be adjusted by selecting the setup function. While viewing the setup function softkeys, after 45 seconds of softkey inactivity, the system reverts to the AUX - VIDEO Page softkeys.

Adjusting the video settings:

- 1) With the AUX-VIDEO Page displayed, press the **SETUP** Softkey.
- 2) Press the **BRIGHT** - or **BRIGHT +**, to adjust display brightness in five percent increments from 0 to 100%.
- 3) Press the **CNTRST-** or **CNTRST +**, to adjust display contrast in five percent increments from 0 to 100%.
- 4) Press the **SAT** - or **SAT +**, to adjust display saturation in five percent increments from 0 to 100%.
- 5) If desired, return the display to the default settings by pressing the **RESET** Softkey.
- 6) Press the **BACK** Softkey to return to the previous softkey level.

Display Selection

Pressing the **HIDE MAP** Softkey removes the map and displays video on the full screen. The softkey label changes to grey with black characters. Pressing the **HIDE MAP** Softkey again restores the map view and the small video image. The softkey label returns to white characters on a black background.

Zoom/Range

Pressing the **VID ZM +** or **VID ZM -** Softkeys increases or decreases video display magnification between 1x and 10x.

The **RANGE** Knob can be used to increase or decrease the range setting on the map display or zoom in and out on the video display. While in the Split-Screen

mode, pressing the **MAP ACTV** or **VID ACTV** Softkey determines which display the **RANGE** Knob adjusts. Pressing the softkey to display **MAP ACTV** allows the **RANGE** Knob to control the range setting of the map display. Pressing the softkey to display **VID ACTV** allows the **RANGE** Knob to control the zoom setting of the video display.

ELECTRONIC CHECKLISTS (OPTIONAL)

The system accesses the checklists from an SD card inserted into the card slot. If the SD card contains an invalid checklist file or no checklist, the Power-up Page messages display 'Checklist File: Invalid' or 'Checklist File: N/A' (not available) and the **CHKLIST** Softkey is not available.

The following colors are used for checklist items:

- Light Blue - Items not selected or checked
- White - Item is selected
- Green - Item has been checked
- Gray - General notes
- Yellow - Caution notes
- Red - Warning notes

Accessing and Navigating Checklists

- 1) From any page on the MFD, select the **CHKLIST** Softkey. The cursor is now flashing in the 'GROUP' field.
- 2) Turn the small **FMS** Knob to select the desired procedure.
- 3) Press the **ENT** Key.
- 4) Turn the small **FMS** Knob to select the desired checklist.
- 5) Press the **ENT** Key. The first checklist item is indicated with white text surrounded by a white box.

- 6) Press the **ENT** Key or select the **CHECK** Softkey to check the selected checklist item. The line item turns green and a checkmark is placed in the associated box. The next line item is automatically selected for checking. Either **FMS** Knob can be used to scroll through the checklist and select the desired checklist item.

Press the **CLR** Key or select the **UNCHECK** Softkey to remove a check mark from an item.

- 7) When all checklist items have been checked, '*Checklist Finished*' is displayed in green text at the bottom left of the checklist window and 'GO TO NEXT CHECKLIST?' is highlighted. If 'GO TO NEXT CHECKLIST?' is selected prior to checking all the checklist items, '*CHECKLIST NOT FINISHED*' will be displayed in yellow text.

- 8) Press the **ENT** Key. If 'GO TO NEXT CHECKLIST?' is displayed when pressing the **ENT** Key, the next checklist in the group will be displayed. If 'EXIT CHECKLISTS?' is displayed when pressing the **ENT** Key, the system will exit the Checklist Page.
- 9) Select the **EXIT** Softkey to exit the Checklist Page and return to the page last viewed. When returning to the Checklist Page after pressing the **EXIT** Softkey, the system will return to the last selected checklist item.

Immediately Accessing Emergency Procedures

- 1) From any page on the MFD, select the **CHKLIST** Softkey or turn the large **FMS** Knob to select the Checklist Page.
- 2) Select the **EMERGENCY** Softkey.
- 3) Turn the **FMS** Knob to select the desired emergency checklist and press the **ENT** Key.
- 4) Press the **ENT** Key or select the **CHECK** Softkey to check the selected emergency checklist item. The line item turns green and a checkmark is placed in the box next to it. The next line item is automatically highlighted for checking.

Either **FMS** Knob can be used to scroll through the checklist and select the desired checklist item.

Press the **CLR** Key or select the **UNCHECK** Softkey to remove a check mark from an item.

- 5) When all checklist items have been checked, '*Checklist Finished*' is displayed in green text at the bottom left of the checklist window and 'GO TO NEXT CHECKLIST?' is highlighted. If 'GO TO NEXT CHECKLIST?' is selected prior to checking all the checklist items, '*CHECKLIST NOT FINISHED*' will be displayed in yellow text.
- 6) Press the **ENT** Key to advance to the next checklist.
- 7) Select the **RETURN** Softkey to return to the previous checklist.
- 8) Select the **EXIT** Softkey to exit the Checklist Page and return to the page last viewed.

BLUETOOTH® MANAGEMENT

The Bluetooth Management Page allows for setting up the installed optional Flight Stream device for a Bluetooth connection between the G1000 and a mobile device running the Garmin Pilot™ application.

The mobile device must be 'paired' with the G1000 in order to use the various functions. Pairing is accomplished by first placing the G1000 in pairing mode by displaying the Bluetooth Management Page. The G1000 is 'discoverable' whenever this page is displayed. The pairing operation is completed from the mobile device and the Garmin Pilot application. See the device Bluetooth pairing instructions and the connection instructions in the Garmin Pilot application.

Viewing the Bluetooth Management Page

- 1) Turn the large **FMS** Knob on the MFD to select the AUX page group.
- 2) Turn the small **FMS** Knob to select the AUX - BLUETOOTH MANAGEMENT page.

Changing the Bluetooth Name

- 1) While viewing the Bluetooth Management Page, press the **FMS** Knob to activate the cursor.
- 2) Turn the large **FMS** Knob to place the cursor in the 'BLUETOOTH NAME' field.
- 3) Enter the desired name by using the large **FMS** Knob to select the character field, and the small **FMS** Knob select the desired alphanumeric character for that field.
- 4) Press the **ENT** Key. The cursor is removed and the new name is displayed.

Enabling/Disabling Flight Plan Importing from Garmin Pilot

- 1) While viewing the Bluetooth Management Page, press the **FMS** Knob to activate the cursor.
- 2) Turn the large **FMS** Knob to place the cursor in the 'FLIGHT PLAN IMPORT' field.
- 3) Turn the small **FMS** Knob to select 'ENABLED' or 'DISABLED'.
- 4) Press the **FMS** Knob to remove the cursor.

Enabling/Disabling Automatic Reconnection of a Specific Paired Device

- 1) While viewing the Bluetooth Management Page, press the **FMS** Knob to activate the cursor.
- 2) Turn the large **FMS** Knob to highlight the desired paired device.
- 3) Turn the small **FMS** Knob to select 'ENABLED' or 'DISABLED'. Selecting 'ENABLED' allows the G1000 to automatically connect to a previously paired device when detected.
- 4) Press the **FMS** Knob to remove the cursor.

Remove a Specific Paired Device from the List of Paired Devices:

- 1) While viewing the Bluetooth Management Page, press the **FMS** Knob to activate the cursor.
- 2) Turn the large **FMS** Knob to highlight the desired paired device.
- 3) Press the **REMOVE** Softkey. A confirmation screen is displayed.
- 4) If necessary, turn the large **FMS** Knob to select 'YES'.
- 5) Press the **ENT** Key to remove the device from the list of paired devices.

ABNORMAL OPERATION

REVERSIONARY MODE

Should a system detected failure occur in either display, the G1000 automatically enters reversionary mode. In reversionary mode, critical flight instrumentation is combined with engine instrumentation on the remaining display.

Reversionary display mode can be manually activated by pressing the **DISPLAY BACKUP** Button on the audio panel.



NOTE: *The Diamond DA62 Pilot's Operating Handbook (POH) always takes precedence over the information found in this section.*

ABNORMAL COM OPERATION

When a COM tuning failure is detected by the system, the emergency frequency (121.500 MHz) is automatically loaded into the active frequency field of the COM radio for which the tuning failure was detected.

HAZARD DISPLAYS WITH LOSS OF GPS POSITION

If GPS position is lost, or becomes invalid, selected hazards being displayed on the Navigation Map Page are removed until GPS position is again established.



Loss of Hazard Functions with Loss of GPS Position

UNUSUAL ATTITUDES

The PFD ‘declutters’ when the aircraft enters an unusual attitude. Only the primary functions are displayed in these situations.

The following information is removed from the PFD (and corresponding softkeys are disabled) when the aircraft experiences unusual attitudes:

- Traffic Annunciations
- AFCS Annunciations
- Flight Director Command Bars
- Inset Map
- Temperatures
- DME Information Window
- Wind Data
- Selected Heading Box
- Selected Course Box
- Transponder Status Box
- System Time
- PFD Setup Menu
- Windows displayed in the lower right corner of the PFD:
 - Timer/References
 - Nearest Airports
 - Flight Plan
 - Messages
 - Procedures
 - ADF/DME Tuning
- Barometric Minimum Descent Altitude Box
- Glideslope, Glide-path, and Vertical Deviation Indicators
- Altimeter Barometric Setting
- Selected Altitude
- VNV Target Altitude

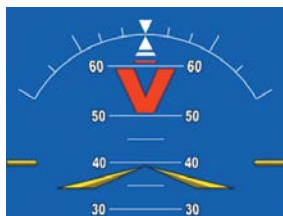

Extreme Pitch Indication

DEAD RECKONING

While in Enroute or Oceanic phase of flight, if the G1000 detects an invalid GPS solution or is unable to calculate a GPS position, the system automatically reverts to Dead Reckoning (DR) Mode. In DR Mode, the G1000 uses its last-known position combined with continuously updated airspeed and heading data (when available) to calculate and display the aircraft’s current estimated position.



NOTE: Dead Reckoning Mode only functions in Enroute (ENR) or Oceanic (OCN) phase of flight. In all other phases, an invalid GPS solution produces a “NO GPS POSITION” annunciation on the map and the G1000 stops navigating in GPS Mode.

DR Mode is indicated on the G1000 by the appearance of the letters ‘DR’ superimposed in yellow over the ‘own aircraft’ symbol as shown in the following figure. In addition, ‘DR’ is prominently displayed, also in yellow, on the HSI slightly above and to the right of the aircraft symbol on the CDI as shown in the following figure. Also, the CDI deviation bar is removed from the display. Lastly, but at the same time, a ‘GPS NAV LOST’ alert message appears on the PFD.

Normal navigation using GPS source data resumes automatically once a valid GPS solution is restored.

It is important to note that estimated navigation data supplied by the G1000 in DR Mode may become increasingly unreliable and must not be used as a sole means of navigation. If, while in DR Mode, airspeed and/or heading data is also lost or not available, the DR function may not be capable of estimating your position and, consequently, the system may display a path that is different than the actual movement of the aircraft. Estimated position information displayed by the G1000 through DR while there is no heading and/or airspeed data available should not be used for navigation.

DR Mode is inherently less accurate than the standard GPS Mode due to the lack of satellite measurements needed to determine a position. Changes in wind speed and/or wind direction compounds the relative inaccuracy of DR Mode. Because of this degraded accuracy, the crew must maintain position awareness using other navigation equipment until GPS-derived position data is restored.



CDI ‘DR’ Indication on PFD



Symbolic Aircraft
(Map pages and Inset Map)

Dead Reckoning Indications

As a result of operating in DR Mode, all GPS-derived data is computed based upon an estimated position and is displayed as yellow text on the display to denote degraded navigation source information. This data includes the following:

- Navigation Status Box fields except Active Leg, TAS, and DTK
- GPS Bearing Pointer
- Wind data and pointers in the Wind Data Box on the PFD
- Track Indicator
- All Bearing Pointer Distances
- Active Flight Plan distances, bearings, and ETE values

Also, while the G1000 is in DR Mode, the autopilot will not couple to GPS, and Terrain Proximity is disabled. Additionally, the accuracy of all nearest information (airports, airspaces, and waypoints) is questionable. Finally, airspace alerts continue to function, but with degraded accuracy.

Flight Instruments

EIS

Nav/Com/XPDR/Audio

AFC

GPS Nav

Flight Planning

Procedures

Hazard Avoidance

Additional Features

Abnormal Operation

Annun/Alerts

Appendix

Index

ANNUNCIATIONS & ALERTS

WARNING ALERTS

Annunciation Window Text	Alerts Window Message	Audio Alert
L ALTN AMPS	Left engine alternator output is >70 amps.	Continuous Aural Tone
R ALTN AMPS	Right engine alternator output is >70 amps.	
L DOOR OPEN	Front, left door is not closed.	
R DOOR OPEN	Front, right door is not closed.	
FWD DOOR OPEN	Left or right baggage door is not closed.	
REAR DOOR OPEN	Rear door is not closed.	
L ENG FIRE	Left engine fire detected.	
R ENG FIRE	Right engine fire detected.	
L ENG TEMP	Left engine coolant temp is >100 deg C.	
R ENG TEMP	Right engine coolant temp is >100 deg C.	
L FUEL PRESS	Left engine fuel pressure is low.	
R FUEL PRESS	Right engine fuel pressure is low.	
L FUEL TEMP	Left fuel temp is greater than 60 deg C.	
R FUEL TEMP	Right fuel temp is greater than 60 deg C.	
L GBOX TEMP	Left engine gearbox temp is >120 deg C.	
R GBOX TEMP	Right engine gearbox temp is >120 deg C.	
L OIL TEMP	Left engine oil temp is greater than 139 deg C.	
R OIL TEMP	Right engine oil temp is greater than 139 deg C.	
L OIL PRES	Left engine oil pressure is less than 0.9 bar.	
R OIL PRES	Right engine oil pressure is less than 0.9 bar.	
L STARTER	Left engine starter is engaged.	
R STARTER	Right engine starter is engaged.	
USP ACTIVE*	USP has engaged autopilot due to slow airspeed.	

* Optional (Garmin ESP™ only)

- Flight Instruments
- EIS
- Nav/Com/XPDR/Audio
- AFCS
- GPS Nav
- Flight Planning
- Procedures
- Hazard Avoidance
- Additional Features
- Abnormal Operation
- Annun/Alerts
- Appendix
- Index

CAUTION ALERTS

Annunciation Window Text	Alerts Window Message	Audio Alert
L ALT AIR OPEN	The alternate air intake door on the left engine is open.	Single Aural Tone
R ALT AIR OPEN	The alternate air intake door on the right engine is open.	
L ALTN FAIL	Left engine alternator has failed.	
R ALTN FAIL	Right engine alternator has failed.	
L AUX FUEL E*	Left auxiliary fuel tank is empty.	
R AUX FUEL E*	Right auxiliary fuel tank is empty.	
CHECK GEAR	Landing gear is not down and locked	
L COOL LVL	Left engine coolant level is low.	
R COOL LVL	Right engine coolant level is low.	
DEICE LVL LO*	De-icing fluid level is low.	
DEIC PRES HI*	De-icing pressure is high.	
DEIC PRES LO*	De-icing pressure is low.	
L ECU A FAIL	Left engine ECU A has failed.	
R ECU A FAIL	Right engine ECU A has failed.	
L ECU B FAIL	Left engine ECU B has failed.	
R ECU B FAIL	Right engine ECU B has failed.	
L FUEL LOW	Left engine main tank fuel quantity is low.	
R FUEL LOW	Right engine main tank fuel quantity is low.	
NO ADC MODES	Autopilot air data modes are not available.	
NO VERT MODES	Autopilot vertical modes are not available.	
PITOT FAIL	Pitot heat has failed.	
PITOT HT OFF	Pitot heat is off.	
STAL HT FAIL	Stall warning heat has failed.	
STAL HT OFF	Stall warning heat is off.	
L VOLTS LOW	Left bus voltage is less than 25 volts.	
R VOLTS LOW	Right bus voltage is less than 25 volts.	

* Optional

ANNUNCIATION ADVISORY

Annunciation Window Text	Alerts Window Message	Audio Alert
L AUXPUMP ON*	Left fuel transfer from aux to main in progress.	No Tone
R AUXPUMP ON*	Right fuel transfer from aux to main in progress.	
L GLOW ON	Left engine glow plug active.	
R GLOW ON	Right engine glow plug active.	

* Optional





MESSAGE ADVISORY ALERTS

Alerts Window Message	Audio Alert
PFD FAN FAIL – The cooling fan for the PFD is inoperative.	None
MFD FAN FAIL – The cooling fan for the MFD is inoperative.	
GIA FAN FAIL – The cooling fan for the GIAs is inoperative.	
ESP DEGRADE* – ESP IAS mode is inoperative.	
ESP FAIL* – ESP is inoperative.	
ESP OFF* – ESP selected off.	
ESP CONFIG* – ESP config error. Config service req'd.	

* Garmin AFCS equipped aircraft with ESP™

* Garmin AFCS equipped aircraft with Garmin ESP™

AFCS ALERTS

Alert Condition	Annunciation	Description
Rudder Mistrim Right		Yaw servo providing sustained force in the indicated direction
Rudder Mistrim Left		
Aileron Mistrim Right		Roll servo providing sustained force in indicated direction
Aileron Mistrim Left		

Alert Condition	Annunciation	Description
Elevator Mistrim Down		Pitch servo providing sustained force in the indicated direction
Elevator Mistrim Up		
Pitch Trim Failure (or Stuck AP TRIM Switch)		If AP engaged, take control of the aircraft and disengage AP If AP disengaged, move AP TRIM switches separately to unstick
Yaw Damper Failure		YD control failure
Roll Failure		Roll axis control failure; AP inoperative
Pitch Failure		Pitch axis control failure; AP inoperative
System Failure		AP and MET are unavailable; FD may still be available
Preflight Test		Performing preflight system test; aural alert sounds at completion Do not press the AP DISC Switch during servo power-up and preflight system tests. Doing so may cause the preflight system test to fail or never to start. Cycle power to the servos if this occurs.
		Preflight system test failed; aural alert sounds at failure

TERRAIN-SVS ALERTS

Alert Type	PFD/MFD Terrain-SVS Page Annunciation	MFD Pop-Up Alert	Aural Message
Reduced Required Terrain Clearance Warning (RTC)			"Warning; Terrain, Terrain"
Imminent Terrain Impact Warning (ITI)			"Warning; Terrain, Terrain"

Alert Type	PFD/MFD Terrain-SVS Page Annunciation	MFD Pop-Up Alert	Aural Message
Reduced Required Obstacle Clearance Warning (ROC)	TERRAIN	WARNING OBSTACLE	"Warning; Obstacle, Obstacle"
Imminent Obstacle Impact Warning (IOI)	TERRAIN	WARNING OBSTACLE	"Warning; Obstacle, Obstacle"
Reduced Required Terrain Clearance Caution (RTC)	TERRAIN	CAUTION TERRAIN	"Caution; Terrain, Terrain"
Imminent Terrain Impact Caution (ITI)	TERRAIN	CAUTION TERRAIN	"Caution; Terrain, Terrain"
Reduced Required Obstacle Clearance Caution (ROC)	TERRAIN	CAUTION OBSTACLE	"Caution; Obstacle, Obstacle"
Imminent Obstacle Impact Caution (IOI)	TERRAIN	CAUTION OBSTACLE	"Caution; Obstacle, Obstacle"

SVS TERRAIN STATUS ANNUNCIATIONS

Alert Type	PFD/MFD TERRAIN-SVS Page Annunciation	Aural Message
System Test Fail	TER FAIL	"Terrain System Failure"
Terrain Alerting is disabled	TER INHB	None
No GPS position or excessively degraded GPS signal	TER N/A	"Terrain System Not Available"
System Test in progress	TER TEST	None
System Test pass	None	"Terrain System Test OK"
GPS signal is re-established	None	"Terrain System Available"

VOICE ALERTS

Voice Alert	Description
"Minimums, minimums"	The aircraft has descended below the preset barometric minimum descent altitude.
"Vertical track"	The aircraft is one minute from Top of Descent. Issued only when vertical navigation is enabled.
"Traffic"	Played when a Traffic Advisory (TA) is issued.
"Traffic Not Available"	The aircraft is outside the Traffic Information Service (TIS) coverage area.
"Traffic, Traffic"	Played when a Traffic Advisory (TA) is issued (TAS system).
"Traffic Advisory System Test Passed"	Played when the TAS system passes a pilot-initiated self test.
"Traffic Advisory System Test Failed"	Played when the TAS system fails a pilot-initiated self test.
"Engaging Autopilot"	The Garmin ESP™ system is engaging the autopilot.
"Airspeed"	Issued when the autopilot is engaged and the airspeed trend vector drops below 65 knots.

TIS ALERTS AND ANNUNCIATIONS

Traffic Map Page Annunciation	Description
NO DATA	Data is not being received from the transponder*
DATA FAILED	Data is being received from the transponder, but a failure is detected in the data stream*
FAILED	The transponder has failed*
UNAVAILABLE	TIS is unavailable or out of range

* Contact a service center or Garmin dealer for corrective action

TIS Failure Annunciations

Mode	Traffic Mode Annunciation (Traffic Map Page)	Traffic Display Enabled Icon (Other Maps)
TIS Operating	OPERATING	
TIS Standby	STANDBY (also shown in white in center of page)	
TIS Failed*	FAIL	

TIS Modes

Traffic Status Banner Annunciation	Description
TA OFF SCALE	A Traffic Advisory is outside the selected display range* Annunciation is removed when traffic comes within the selected display range
TA X.X ± XX ↓	System cannot determine bearing of Traffic Advisory** Annunciation indicates distance in nm, altitude separation in hundreds of feet, and altitude trend arrow (climbing/descending)
AGE MM:SS	Appears if traffic data is not refreshed within 6 seconds If after another 6 seconds data is not received, traffic is removed from the display The quality of displayed traffic information is reduced as the age increases
TRFC COAST	The displayed data is not current (6 to 12 seconds since last message) The quality of displayed traffic information is reduced when this message is displayed
TRFC RMVD	Traffic is removed because it is too old for coasting (12 to 60 seconds since last message) Traffic may exist within the selected display range, but it is not displayed

- Flight Instruments
- EIS
- Nav/Com/XPDR/Audio
- AFCS
- GPS Nav
- Flight Planning
- Procedures
- Hazard Avoidance
- Additional Features
- Abnormal Operation
- Annun/Alerts
- Appendix
- Index

Flight Instruments
EIS
Nav/Com/XPDR/Audio
AFCs
GPS Nav
Flight Planning
Procedures
Hazard Avoidance
Additional Features
Abnormal Operation
Annun/ Alerts
Appendix
Index

Traffic Status Banner Annunciation	Description
TRFC FAIL	Traffic data has failed
NO TRFC DATA	Traffic data has not been detected
TRFC UNAVAIL	The traffic service is unavailable or out of range

*Shown as symbol on Traffic Map Page
 **Shown in center of Traffic Map Page

TIS Traffic Status Banner Annunciations

TAS ALERTS AND ANNUNCIATIONS

Mode	Traffic Mode Annunciation (Traffic Map Page)	Traffic Display Enabled Icon (Other Maps)
TAS Operating	OPERATING	
TAS Failed	FAIL	

TAS Modes

Traffic Map Page Annunciation	Description
NO DATA	Data is not being received from the TAS unit
DATA FAILED	Data is being received from the TAS unit, but the unit is self-reporting a failure
FAILED	Incorrect data format received from the TAS unit

TAS Failure Annunciations







Traffic Status Banner Annunciation	Description
TA OFF SCALE	A Traffic Advisory is outside the selected display range* Annunciation is removed when traffic comes within the selected display range
TA X.X ± XX ↓	System cannot determine bearing of Traffic Advisory** Annunciation indicates distance in nm, altitude separation in hundreds of feet, and altitude trend arrow (climbing/descending)
TRFC FAIL	TAS unit has failed (unit is self-reporting a failure or sending incorrectly formatted data)
NO TRFC DATA	Data is not being received from the TAS unit

*Shown as symbol on Traffic Map Page

**Shown in center of Traffic Map Page

TAS Traffic Status Annunciations

ADS-B ALERTS AND ANNUNCIATIONS

Mode	Traffic Mode Annunciation (Traffic Map Page)	Traffic Map Page Center Banner Annunciation	Traffic Display Status Icon (Other Maps)
ADS-B System Test Initiated	ADS-B: TEST	TEST MODE	
ADS-B Operating in Airborne Mode	ADS-B: AIRB	ADS-B: AIRB	
ADS-B Operating in Surface Mode	ADS-B: SURF	ADS-B: SURF	
ADS-B Traffic Off	ADS-B: OFF	ADS-B TRFC OFF	
ADS-B Traffic Not Available	ADS-B: N/A	ADS-B TRFC N/A	
ADS-B Failed*	ADS-B: FAIL	ADS-B TRFC FAIL	

Traffic Modes

Traffic Map Page Center Annunciation	Description
NO DATA	Data is not being received from the traffic unit
DATA FAILED	Data is being received from the traffic unit, but the unit is self-reporting a failure
ADS-B TRFC FAIL	Incorrect data format received from the traffic unit

Traffic Failure Annunciations

Traffic Status Banner Annunciation	Description
TA OFF SCALE	A Traffic Advisory is outside the selected display range*. Annunciation is removed when traffic comes within the selected display range.
TA X.X ± XX ↓	System cannot determine bearing of Traffic Advisory**. Annunciation indicates distance in nm, altitude separation in hundreds of feet, and altitude trend arrow (climbing/descending).
TRFC FAIL	Traffic unit has failed (unit is self-reporting a failure or sending incorrectly formatted data)
NO TRFC DATA	Data is not being received from the traffic unit

*Shown as symbol on Traffic Map Page

**Shown in center of Traffic Map Page

Traffic Status Annunciations

WEATHER RADAR ALERTS AND ANNUNCIATIONS

Radar Mode	Radar Mode Annunciation Box†	Center Banner Annunciation
Standby	STANDBY	STANDBY
Standby (During Warm-Up), applicable to GWX 68 only	STANDBY	WARM-UP XX (XX indicates number of seconds remaining in warm-up)
Weather	WEATHER	None
Ground Mapping	GROUND MAPPING	None
Off	OFF	OFF
Radar Failed*	FAIL	RADAR FAIL

† Annunciations in this column appear in white text in the Weather Radar Mode box on the Navigation Map Page.

Radar Modes on the Weather Radar Page

Radar Feature Status	Description
ACT ON	Altitude compensated tilt feature is enabled (GWX 70 only)
ACT OFF	Altitude compensated tilt feature is disabled (GWX 70 only)
STAB ON	Antenna stabilization is selected on.
STAB OFF	Antenna stabilization is selected off.
STAB INOP	The radar is not receiving pitch and roll information. The antenna stabilization feature is inoperative.

Radar Feature Annunciations on the Weather Radar Page

Weather Radar Page Center Banner Annunciation	Description
BAD CONFIG	The radar configuration is invalid. The radar should be serviced.
RDR FAULT	The radar unit is reporting a fault. The radar should be serviced.
RADAR FAIL	The system is not receiving valid data from the radar unit. The system should be serviced.

Abnormal Radar Status Annunciations on the Weather Radar Page

GDL 69A SXM DATA LINK RECEIVER MESSAGES

Message	Message Location	Description
CHECK ANTENNA	XM Radio Page - active channel field	Data Link Receiver antenna error; service required
UPDATING	XM Radio Page - active channel field	Data Link Receiver updating encryption code
NO SIGNAL	XM Radio Page - active channel field Weather Datalink Page - center of page	Loss of signal; signal strength too low for receiver
LOADING	XM Radio Page - active channel field	Acquiring channel audio or information
OFF AIR	XM Radio Page - active channel field	Channel not in service
---	XM Radio Page - active channel field	Missing channel information
WEATHER DATA LINK FAILURE	Weather Datalink Page - center of page	No communication from Data Link Receiver within last 5 minutes
ACTIVATION REQUIRED	Weather Datalink Page - center of page	SiriusXM subscription is not activated

GDL 69A SXM Data Link Receiver Messages

ADS-B STATUS PAGE MESSAGES

ADS-B Status Page Item	Status Message	Description
Traffic Application Status: AIRBORNE (AIRB), SURFACE (SURF), AIRBORNE ALERTS (CSA)	ON	Traffic application is currently on. Required input data is available, and it meets performance requirements.
	AVAILABLE TO RUN	Traffic application is not currently active, but application is ready to run when condition(s) determine the application should be active. Required input data is available, and it meets performance requirements.
	NOT AVAILABLE	Traffic application is not available. Required input data is available, but it does not meet performance requirements.
	FAULT	Traffic application is not available. Required input data is not available or the application has failed.
	NOT CONFIGURED	Traffic application is not available, because it has not been configured. If this annunciation persists, the system should be serviced.
	-----	Traffic application status is invalid or unknown.
TIS-B/ADS-R Coverage	AVAILABLE	The system is receiving the ADS-R coverage from an FAA ground station.
	NOT AVAILABLE	The system is not receiving the ADS-R coverage from an FAA ground station.
	-----	ADS-R coverage is invalid or unknown.
GPS Status: GPS Source	External #1	The GDL 88 is using the #1 GPS receiver for the GPS position source.
	External #2	The GDL 88 is using the #2 GPS receiver for the GPS position source.
	-----	The GPS source is invalid or unknown.

- Flight Instruments
- EIS
- Nav/Com/XPDR/Audio
- AFCs
- GPS Nav
- Flight Planning
- Procedures
- Hazard Avoidance
- Additional Features
- Abnormal Operation
- Annun/Alerts
- Appendix
- Index

ADS-B Status Page Item	Status Message	Description
Ground Uplink Status: Last uplink	Number of minutes, or '-----'	Displays the number of minutes since the last uplink from a ground station occurred. If no uplink has been received, or the status is invalid, dashes appear instead of a number of minutes.
FIS-B Weather Status: FIS-B Processing	ENABLED	The FIS-B weather feature is enabled to process and display FIS-B weather products.
	DISABLED	The FIS-B weather feature is disabled.
	-----	No data received from the GDL 88 UAT.
Weather Products: AIRMET CONUS NEXRAD METAR METAR GRAPHICAL NOTAM/TFR PIREP REGIONAL NEXRAD SIGMET TAF WINDS/TEMPS ALOFT	AVAILABLE	FIS-B weather data is available for display for the weather product.
	NOT AVAILABLE	FIS-B weather data is not available for the weather product, and/or the system is not receiving the FIS-B weather service.
	AWAITING DATA	The system is receiving the FIS-B weather service, and is waiting to receive the weather product from the FIS-B data broadcast.

G1000 SYSTEM MESSAGE ADVISORIES

Message Advisory	Comments
ABORT APR – Loss of GPS navigation. Abort approach.	Abort approach due to loss of GPS navigation.
ADC1 ALT EC – ADC1 altitude error correction is unavailable.	GDC1 is reporting that the altitude error correction is unavailable.
ADC1 AS EC – ADC1 airspeed error correction is unavailable.	GDC1 is reporting that the airspeed error correction is unavailable.

Message Advisory	Comments
AHRS1 CAL – AHRS1 calibration version error. Svc req'd.	The #1 AHRS calibration version error. The system should be serviced.
AHRS1 GPS – AHRS1 using backup GPS source.	The #1 AHRS is using the backup GPS path. Primary GPS path has failed. The G1000 system should be serviced when possible.
AHRS1 GPS – AHRS1 not receiving any GPS information.	The #1 AHRS is not receiving any or any useful GPS information. Check AFMS limitations. The G1000 system should be serviced.
AHRS1 GPS – AHRS1 not receiving backup GPS information.	The #1 AHRS is not receiving backup GPS information. The G1000 system should be serviced.
AHRS1 GPS – AHRS1 operating exclusively in no-GPS mode.	The #1 AHRS is operating exclusively in no-GPS mode. The G1000 system should be serviced.
AHRS1 SRVC – AHRS1 Magnetic-field model needs update.	The #1 AHRS earth magnetic field model is out of date. Update magnetic field model when practical.
AHRS1 TAS – AHRS1 not receiving airspeed.	The #1 AHRS is not receiving true airspeed from the air data computer. The AHRS relies on GPS information to augment the lack of airspeed. The G1000 system should be serviced.
APR DWNGRADE – Approach downgraded.	Use LNAV minima when approach is downgraded.
ARSPC AHEAD – Airspace ahead less than 10 minutes.	Special use airspace is ahead of aircraft. The aircraft will penetrate the airspace within 10 minutes.
ARSPC NEAR – Airspace near – less than 2 nm.	Special use airspace is within 2 nm of the aircraft position.
ARSPC NEAR – Airspace near and ahead.	Special use airspace is near and ahead of the aircraft position.
APR INACTV – Approach is not active.	The system notifies the pilot that the loaded approach is not active. Activate approach when required.

Message Advisory	Comments
AUDIO MANIFEST - Audio software mismatch, communication halted.	The GDC 74B has incorrect software installed. The G1000 system should be serviced.
CHECK CRS – Database course for LOC2 / [LOC ID] is [CRS]°.	Selected course for LOC2 differs from published localizer course by more than 10 degrees.
CNFG MODULE – PFD1 configuration module is inoperative.	The PFD1 configuration module backup memory has failed. The G1000 system should be serviced.
COM1 CONFIG – COM1 config error. Config service req'd.	The COM1 configuration settings do not match backup configuration memory. The G1000 system should be serviced
COM1 PTT – COM1 push-to-talk key is stuck.	The COM1 aexternal push-to-talk switch is stuck in the enable (or “pressed”) position. Press the PTT switch again to cycle its operation. If the problem persists, the G1000 system should be serviced.
COM1 RMT XFR – COM1 remote transfer key is stuck.	The COM1 transfer switch is stuck in the enabled (or “pressed”) position. Press the transfer switch again to cycle its operation. If the problem persists, the G1000 system should be serviced.
COM1 SERVICE – COM1 needs service. Return unit for repair.	The system has detected a failure in COM1. COM1 may still be usable. The G1000 system should be serviced when possible.
COM1 TEMP – COM1 over temp. Reducing transmitter power.	The system has detected an over temperature condition in COM1. The transmitter operates at reduced power. If the problem persists, the G1000 system should be serviced.
COM2 CONFIG – COM2 config error. Config service req'd.	The COM2 configuration settings do not match backup configuration memory. The G1000 system should be serviced

Message Advisory	Comments
COM2 PTT – COM2 push-to-talk key is stuck.	The COM2 external push-to-talk switch is stuck in the enable (or “pressed”) position. Press the PTT switch again to cycle its operation. If the problem persists, the G1000 system should be serviced.
COM2 RMT XFR – COM2 remote transfer key is stuck.	The COM2 transfer switch is stuck in the enabled (or “pressed”) position. Press the transfer switch again to cycle its operation. If the problem persists, the G1000 system should be serviced.
COM2 SERVICE – COM2 needs service. Return unit for repair.	The system has detected a failure in COM2. COM2 may still be usable. The G1000 system should be serviced when possible.
COM2 TEMP – COM2 over temp. Reducing transmitter power.	The system has detected an over temperature condition in COM2. The transmitter operates at reduced power. If the problem persists, the G1000 system should be serviced.
DATA LOST – Pilot stored data was lost. Recheck settings.	The pilot profile data was lost. System reverts to default pilot profile and settings. The pilot may reconfigure the MFD & PFD with preferred settings, if desired.
DB CHANGE – Database changed. Verify user modified procedures.	This occurs when a stored flight plan contains procedures that have been manually edited. This alert is issued only after an navigation database update. Verify that the user-modified procedures in stored flight plans are correct and up to date.
DB CHANGE – Database changed. Verify stored airways.	This occurs when a stored flight plan contains an airway that is no longer consistent with the navigation database. This alert is issued only after an navigation database update. Verify use of airways in stored flight plans and reload airways as needed.

- Flight Instruments
- EIS
- Nav/Com/XPDR/Audio
- AFCS
- GPS Nav
- Flight Planning
- Procedures
- Hazard Avoidance
- Additional Features
- Abnormal Operation
- Annun/Alerts
- Appendix
- Index

Message Advisory	Comments
DB MISMATCH – Navigation database mismatch. Xtalk is off.	The PFD and MFD have different navigation database versions or types installed. Crossfill is off. Check the AUX-SYSTEM STATUS Page to determine versions or regions. Also, check the AUX-SYSTEM STATUS Page for a database synchronization function not completed. After synchronization is complete, power must be turned off, then on.
DB MISMATCH – Obstacle database mismatch.	The PFD and MFD have different obstacle database versions or types installed. Check the AUX-SYSTEM STATUS Page to determine versions or regions. Also, check the AUX-SYSTEM STATUS Page for a database synchronization function not completed. After synchronization is complete, power must be turned off, then on.
DB MISMATCH – Standby Navigation database mismatch.	The PFD and MFD have different standby navigation database versions or types installed. Check the AUX-SYSTEM STATUS Page to determine versions or regions. Also, check the AUX-SYSTEM STATUS Page for a database synchronization function not completed. After synchronization is complete, power must be turned off, then on.
DB MISMATCH – Terrain database mismatch.	The PFD and MFD have different terrain database versions or types installed. Check the AUX-SYSTEM STATUS Page to determine versions or regions. Also, check the AUX-SYSTEM STATUS Page for a database synchronization function not completed. After synchronization is complete, power must be turned off, then on.
DME CHECK RANGE – DME range disagreement. Check position sensors.	A failure or disagreement has been detected in a DME receiver. Check position sensors.
FAILED PATH – A data path has failed.	A data path connected to the GDU or the GIA 63W has failed.

Message Advisory	Comments
FPL TRUNC – Flight plan has been truncated.	This occurs when a newly installed navigation database eliminates an obsolete approach or arrival used by a stored flight plan. The obsolete procedure is removed from the flight plan. Update flight plan with current arrival or approach.
FPL WPT LOCK – Flight plan waypoint is locked.	Upon power-up, the G1000 system detects that a stored flight plan waypoint is locked. This occurs when an navigation database update eliminates an obsolete waypoint. The flight plan cannot find the specified waypoint and flags this message. This can also occur with user waypoints in a flight plan that is deleted. Remove the waypoint from the flight plan if it no longer exists in any database, OR update the waypoint name/identifier to reflect the new information.
FPL WPT MOVE – Flight plan waypoint moved.	The system has detected that a waypoint coordinate has changed due to a new navigation database update. Verify that stored flight plans contain correct waypoint locations.

G/S1 FAIL – G/S1 is inoperative.	A failure has been detected in glideslope receiver 1. The G1000 system should be serviced.
G/S1 SERVICE – G/S1 needs service. Return unit for repair.	A failure has been detected in glideslope receiver 1. The receiver may still be available. The G1000 system should be serviced when possible.
G/S2 FAIL – G/S2 is inoperative.	A failure has been detected in glideslope receiver 2. The G1000 system should be serviced.
G/S2 SERVICE – G/S2 needs service. Return unit for repair.	A failure has been detected in glideslope receiver 2. The receiver may still be available. The G1000 system should be serviced when possible.

	Message Advisory	Comments
Flight Instruments	GDC1 MANIFEST – GDC1 software mismatch, communication halted.	The GDC 74A has incorrect software installed. The G1000 system should be serviced.
EIS	GDL59 CONFIG – GDL 59 config error. Config service req'd.	GDL 59 configuration settings do not match those of backup configuration memory. The system should be serviced.
Nav/Com/XPDR/Audio	GDL59 FAIL – GDL 59 has failed.	A fault has been detected in the GDL 59. The receiver is unavailable. The system should be serviced.
AFCs	GDL59 RTR FAIL – The GDL 59 router has failed.	A fault has been detected in the GDL 59 router. The system should be serviced.
GPS Nav	GDL59 SERVICE – GDL 59 needs service. Return unit for repair.	A fault has been detected in the GDL 59. The system should be serviced.
Flight Planning	GDL69 CONFIG – GDL 69 config error. Config service req'd.	GDL 69/69A or GDL 69/69A SXM configuration settings do not match those of backup configuration memory. The G1000 system should be serviced.
Procedures	GDL69 FAIL – GDL 69 has failed.	A failure has been detected in the DL 69/69A or GDL 69/69A SXM. The receiver is unavailable. The G1000 system should be serviced.
Hazard Avoidance	GDL69 MANIFEST – GDL software mismatch, communication halted.	The GDL 69/69A or GDL 69/69A SXM has incorrect software installed. The G1000 system should be serviced.
Additional Features	GDL88 ADS-B 1090 - ADS-B fault. 1090 receiver failure.	A failure has been detected in the 1090 receiver.
Abnormal Operation	GDL88 ADS-B NO POS - GDL88 is not receiving position information.	The GDL 88 is not able to receive position information.
Annun/Alerts	GDL88 ADS-B NO TX - GDL88 Failure	Unable to transmit GDL 88 messages.
Appendix	GDL88 ADS-B TRFC - GDL 88 ADS-B traffic has failed	The GDL 88 is incapable of processing traffic information.
Index		

Message Advisory	Comments
GDL88 ADS-B UAT - ADS-B fault. UAT receiver failure.	A failure has been detected in the UAT receiver.
GDL88 ANTENNA - GDL 88 Antenna fault	The GDL 88 Antenna has failed.
GDL88 CONFIG – GDL88 config error.	The GDL 88 and GDU have incompatible configurations. This alert is also set when the GDL 88 has an invalid mode S address configured or the mode S address does not match both XPDR mode S addresses.
GDL88 CSA FAIL -- ADS-B Airborne alerts failure.	GDL 88 ADS-B Conflict Situational Awareness (CSA) is unavailable.
GDL88 FAIL - Unable to transmit ADS-B messages.	The PFD has lost connection with the GDL 88.
GDL88 PRES ALT - GDL88 is not receiving pressure altitude.	The GDL 88 is not receiving pressure altitude data.
GDL88 SERVICE – GDL88 needs service.	Return unit for repair.
GDL88 XPDR - GDL88 not receiving XPDR code. Check XPDR mode.	The GDL 88 is not receiving transponder code. The transponder should be in ALT mode when airborne.
GEA1 CONFIG – GEA1 config error. Config service req'd.	The GEA1 configuration settings do not match those of backup configuration memory. The G1000 system should be serviced.
GEA1 MANIFEST – GEA1 software mismatch, communication halted.	The #1 GEA 71 has incorrect software installed. The G1000 system should be serviced.
GEO LIMITS – AHRS1 too far North/South, no magnetic compass.	The aircraft is outside geographical limits for approved AHRS operation. Heading is flagged as invalid.
GFC MANIFEST – GFC software mismatch, communication halted.	Incorrect servo software is installed, or gain settings are incorrect.

	Message Advisory	Comments
Flight Instruments	GIA1 CONFIG – GIA1 audio config error. Config service req'd.	The GIA1 have an error in the audio configuration. The G1000 system should be serviced.
EIS	GIA1 CONFIG – GIA1 config error. Config service req'd.	The GIA1 configuration settings do not match backup configuration memory. The G1000 system should be serviced.
Nav/Com/XPDR/Audio	GIA1 COOLING – GIA1 temperature too low.	The GIA1 and/or GIA2 temperature is too low to operate correctly. Allow units to warm up to operating temperature.
AFC	GIA1 COOLING – GIA1 over temperature.	The GIA1 temperature is too high. If problem persists, the G1000 system should be serviced.
GPS Nav	GIA1 MANIFEST – GIA1 software mismatch, communication halted.	The GIA1 1 has incorrect software installed. The G1000 system should be serviced.
Flight Planning	GIA1 SERVICE – GIA1 needs service. Return the unit for repair.	The GIA1 self-test has detected a problem in the unit. The G1000 system should be serviced.
Procedures	GIA2 CONFIG – GIA2 audio config error. Config service req'd.	The GIA2 have an error in the audio configuration. The G1000 system should be serviced.
Hazard Avoidance	GIA2 CONFIG – GIA2 config error. Config service req'd.	The GIA2 configuration settings do not match backup configuration memory. The G1000 system should be serviced.
Additional Features	GIA2 COOLING – GIA2 over temperature.	The GIA2 temperature is too high. If problem persists, the G1000 system should be serviced.
Abnormal Operation	GIA2 COOLING – GIA2 temperature too low.	The GIA2 temperature is too low to operate correctly. Allow units to warm up to operating temperature.
Annun/Alerts	GIA2 MANIFEST – GIA2 software mismatch, communication halted.	The GIA 2 has incorrect software installed. The G1000 system should be serviced.
Appendix		
Index		

Message Advisory	Comments
GIA2 SERVICE – GIA2 needs service. Return the unit for repair.	The GIA2 self-test has detected a problem in the unit. The G1000 system should be serviced.
GMA1 CONFIG – GMA1 config error. Config service req'd.	The audio panel configuration settings do not match backup configuration memory. The G1000 system should be serviced.
GMA1 FAIL – GMA1 is inoperative.	The audio panel self-test has detected a failure. The audio panel is unavailable. The G1000 system should be serviced.
GMA1 MANIFEST – GMA1 software mismatch, communication halted.	The audio panel has incorrect software installed. The G1000 system should be serviced.
GMA1 SERVICE – GMA1 needs service. Return unit for repair.	The audio panel self-test has detected a problem in the unit. Certain audio functions may still be available, and the audio panel may still be usable. The G1000 system should be serviced when possible.
GMU1 MANIFEST – GMU1 software mismatch, communication halted.	The GMU 44 has incorrect software installed. The G1000 system should be serviced.
GRA1 CAL – GRA1 calibration. Service req'd.	GRA1 has improper calibration. The system should be serviced.
GRA1 CONFIG – GRA1 config error. Config service req'd.	The GRA and GDU have incompatible configurations.
GRA1 MANIFEST – GRA1 software mismatch, communication halted.	The GRA has incorrect software installed. The system should be serviced.
GRA1 SERVICE – GRA1 needs service. Return unit for repair	The GRA self-test has detected a problem in the unit. The system should be serviced.
GRA1 TEMP – GRA1 over temperature.	The system has detected an over temperature condition in GRA1.
GPS NAV LOST – Loss of GPS navigation. Insufficient satellites.	Loss of GPS navigation due to insufficient satellites.

	Message Advisory	Comments
Flight Instruments	GPS NAV LOST – Loss of GPS navigation. Position error.	Loss of GPS navigation due to position error.
EIS	GPS NAV LOST – Loss of GPS navigation. GPS fail.	Loss of GPS navigation due to GPS failure.
Nav/Com/XPDR/Audio	GPS1 SERVICE – GPS1 needs service. Return unit for repair.	A failure has been detected in the GPS1 and/or GPS2 receiver. The receiver may still be available. The G1000 system should be serviced.
AFC	GPS2 SERVICE – GPS2 needs service. Return unit for repair.	
GPS Nav	GRS1 MANIFEST – GRS1 software mismatch, communication halted.	The #1 AHRS has incorrect software installed. The G1000 system should be serviced.
Flight Planning	GSR1 FAIL – GSR1 has failed.	A failure has been detected in the GSR 56. The transceiver is unavailable. The G1000 system should be serviced.
Procedures	GTX1 MANIFEST – GTX1 software mismatch, communication halted.	The transponder has incorrect software installed. The G1000 system should be serviced.
Hazard Avoidance	GWX CONFIG – GWX config error. Config service req'd.	GWX 68/GWX 70 configuration settings do not match those of the GDU configuration. The G1000 system should be serviced.
Additional Features	GWX FAIL – GWX is inoperative.	The GDU is not receiving status packet from the GWX 68/GWX 70 is reporting a fault. The GWX 68/GWX 70 radar system should be serviced.
Abnormal Operation	GWX1 MANIFEST – GWX software mismatch, communication halted.	The GWX 68/GWX 70 has incorrect software installed. The G1000 system should be serviced.
Annun/Alerts	GWX SERVICE – Needs service. Return unit for repair.	A failure has been detected in the GWX 68/GWX 70. The GWX 68/GWX 70 may still be usable.
Appendix	HDG FAULT – AHRS1 magnetometer fault has occurred.	A fault has occurred in the #1 GMU 44. Heading is flagged as invalid. The AHRS uses GPS for backup mode operation. The G1000 system should be serviced.
Index		

Message Advisory	Comments
HW MISMATCH – GIA hardware mismatch. GIA1 communication halted.	A GIA mismatch has been detected, where only one is SBAS capable.
HW MISMATCH – GIA hardware mismatch. GIA2 communication halted.	
INSIDE ARSPC – Inside airspace.	The aircraft is inside the airspace.
INVALID ADM – Invalid ADM: ATN communication halted.	Data link avionics were not configured correctly and therefore will not be able to communicate with the ground network.

LOCKED FPL – Cannot navigate locked flight plan.	This occurs when the pilot attempts to activate a stored flight plan that contains locked waypoint. Remove locked waypoint from flight plan. Update flight plan with current waypoint.
LOI – GPS integrity lost. Crosscheck with other NAVS.	GPS integrity is insufficient for the current phase of flight.
LRG MAG VAR – Verify all course angles.	The GDU's internal model cannot determine the exact magnetic variance for geographic locations near the magnetic poles. Displayed magnetic course angles may differ from the actual magnetic heading by more than 2°.

MANIFEST – MFD1 software mismatch, communication halted.	The PFD and/or MFD has incorrect software installed. The G1000 system should be serviced.
MANIFEST – PFD1 software mismatch, communication halted.	
MFD1 CONFIG – MFD1 config error. Config service req'd.	The MFD configuration settings do not match backup configuration memory. The G1000 system should be serviced.

	Message Advisory	Comments
Flight Instruments	MFD1 COOLING – MFD1 has poor cooling. Reducing power usage.	The PFD and/or MFD is overheating and is reducing power consumption by dimming the display. If problem persists, the G1000 system should be serviced.
EIS	MFD1 DB ERR – MFD1 Airport Directory database error exists.	The MFD detected a failure in the Airport Directory database. Ensure that the data card is properly inserted. Replace data card. If problem persists, the system should be serviced.
Nav/Com/XPDR/Audio	MFD1 DB ERR – MFD1 basemap database error exists.	The MFD detected a failure in the basemap database.
AFC	MFD1 DB ERR – MFD1 Chartview database error exists.	The MFD detected a failure in the ChartView database (optional feature). Ensure that the data card is properly inserted. data card. If problem persists, the G1000 system should be serviced.
GPS Nav	MFD1 DB ERR – MFD1 FliteCharts database error exists.	The MFD detected a failure in the FliteCharts database (optional feature). Ensure that the data card is properly inserted. Replace data card. If problem persists, the G1000 system should be serviced.
Flight Planning	MFD1 DB ERR – MFD1 multiple database errors exists.	The MFD detected a failure in more than one database. If problem persists, the system should be serviced.
Procedures	MFD1 DB ERR – MFD1 navigation database error exists.	The MFD detected a failure in the navigation database. Attempt to reload the navigation database. If problem persists, the G1000 system should be serviced.
Hazard Avoidance	MFD1 DB ERR – MFD1 obstacle database error exists.	The MFD detected a failure in the obstacle database. Ensure that the data card is properly inserted. Replace data card. If problem persists, the G1000 system should be serviced.
Additional Features	MFD1 DB ERR – MFD1 obstacle database missing.	The obstacle database is present on another LRU, but is missing on the specified LRU.
Abnormal Operation		
Annun/Alerts		
Appendix		
Index		

Message Advisory	Comments
MFD1 DB ERR – MFD1 Safe Taxi database error exists.	The MFD detected a failure in the Safe Taxi database. Ensure that the data card is properly inserted. Replace data card. If problem persists, the G1000 system should be serviced.
MFD1 DB ERR – MFD1 terrain database error exists.	The MFD detected a failure in the terrain database. Ensure that the terrain card is properly inserted in display. Replace terrain card. If problem persists, the G1000 system should be serviced.
MFD1 DB ERR – MFD1 terrain database error exists.	The MFD detected a failure in the terrain database. Ensure that the terrain card is properly inserted in display. Replace terrain card. If problem persists, the G1000 system should be serviced.
MFD1 DB ERR – MFD1 terrain database missing.	The terrain database is present on another LRU, but is missing on the specified LRU.
MFD1 SERVICE – MFD1 needs service. Return unit for repair.	The MFD self-test has detected a problem. The G1000 system should be serviced.
MFD1 KEYSTK – MFD1 [key name] is stuck.	A key is stuck on the MFD bezel. Attempt to free the stuck key by pressing it several times. The G1000 system should be serviced if the problem persists.
MFD1 VOLTAGE – MFD1 has low voltage. Reducing power usage	The MFD voltage is low. The G1000 system should be serviced.
NAV1 RMT XFR – NAV1 remote transfer key is stuck.	The remote NAV1 transfer switch is stuck in the enabled (or “pressed”) state. Press the transfer switch again to cycle its operation. If the problem persists, the G1000 system should be serviced.
NAV1 SERVICE – NAV1 needs service. Return unit for repair.	A failure has been detected in the NAV1 receiver. The receiver may still be available. The G1000 system should be serviced.

- Flight Instruments
- EIS
- Nav/Com/XPDR/Audio
- AFCS
- GPS Nav
- Flight Planning
- Procedures
- Hazard Avoidance
- Additional Features
- Abnormal Operation
- Annun/Alerts
- Appendix
- Index

	Message Advisory	Comments
Flight Instruments	NAV2 RMT XFR – NAV2 remote transfer key is stuck.	The remote NAV2 transfer switch is stuck in the enabled (or “pressed”) state. Press the transfer switch again to cycle its operation. If the problem persists, the G1000 system should be serviced.
EIS		
Nav/Com/XPDR/Audio	NAV2 SERVICE – NAV2 needs service. Return unit for repair.	A failure has been detected in the NAV2 receiver. The receiver may still be available. The G1000 system should be serviced.
AFCs		
GPS Nav	NON WGS84 WPT – Do not use GPS for navigation to [xxxx]	The position of the selected waypoint [xxxx] is not calculated based on the WGS84 map reference datum and may be positioned in error as displayed. Do not use GPS to navigate to the selected non-WGS84 waypoint..

Flight Planning	PDF1 DB ERR – PFD1 basemap database error exists.	The PFD detected a failure in the basemap database.
Procedures	PDF1 DB ERR – PFD1 multiple database errors exists.	The PFD detected a failure in more than one database. If problem persists, the system should be serviced.
Hazard Avoidance	PDF1 DB ERR – PFD1 navigation database error exists.	The PFD detected a failure in the navigation database. Attempt to reload the navigation database. If problem persists, the G1000 system should be serviced.
Additional Features		
Abnormal Operation	PDF1 DB ERR – PFD1 obstacle database missing.	The obstacle database is present on another LRU, but is missing on the specified LRU.
Annun/Alerts	PDF1 DB ERR – PFD1 Safe Taxi database error exists.	The PFD detected a failure in the Safe Taxi database. Ensure that the data card is properly inserted. Replace data card. If problem persists, the G1000 system should be serviced.
Appendix	PDF1 DB ERR – PFD1 terrain database error exists.	The PFD detected a failure in the terrain database. Ensure that the terrain card is properly inserted in display. Replace terrain card. If problem persists, the G1000 system should be serviced.
Index		

Message Advisory	Comments
PFD1 DB ERR – PFD1 terrain database missing.	The terrain database is present on another LRU, but is missing on the specified LRU.
PFD1 CONFIG – PFD1 config error. Config service req'd.	The PFD configuration settings do not match backup configuration memory. The G1000 system should be serviced.
PFD1 COOLING – PFD1 has poor cooling. Reducing power usage.	The PFD is overheating and is reducing power consumption by dimming the display. If problem persists, the G1000 system should be serviced.
PFD1 KEYSTK – PFD1 [key name] is stuck.	A key is stuck on the PFD bezel. Attempt to free the stuck key by pressing it several times. The G1000 system should be serviced if the problem persists.
[PFD1 or MFD1] CARD 1 REM – Card 1 was removed. Reinsert card.	The SD card was removed from the top card slot of the specified PFD or MFD. The SD card needs to be reinserted.
[PFD1 or MFD1] CARD 2 REM – Card 2 was removed. Reinsert card.	The SD card was removed from the bottom card slot of the specified PFD or MFD. The SD card needs to be reinserted.
[PFD1 or MFD1] CARD 1 ERR – Card 1 is invalid.	The SD card in the top card slot of the specified PFD or MFD contains invalid data.
[PFD1 or MFD1] CARD 2 ERR – Card 2 is invalid.	The SD card in the bottom card slot of the specified PFD or MFD contains invalid data.
PFD1 SERVICE – PFD1 needs service. Return unit for repair.	The PFD self-test has detected a problem. The G1000 system should be serviced.
PFD1 VOLTAGE – PFD1 has low voltage. Reducing power usage	The PFD1 voltage is low. The G1000 system should be serviced.
PTK FAIL – Parallel track unavailable: invalid leg type.	Invalid leg type for parallel offset.
PTK FAIL – Parallel track unavailable: past IAF.	IAF waypoint for parallel offset has been passed.
PTK FAIL – Parallel track unavailable: bad geometry.	Bad parallel track geometry.

- Flight Instruments
- EIS
- Nav/Com/XPDR/Audio
- AFCS
- GPS Nav
- Flight Planning
- Procedures
- Hazard Avoidance
- Additional Features
- Abnormal Operation
- Annun/Alerts
- Appendix
- Index

Message Advisory	Comments
REGISTER CONNEXT – Data services are inoperative, register w/Connex.	The GDL 59 is not registered with Garmin Connex, or its current registration data has failed authentication.
SCHEDULER [#] – <message>.	Message criteria entered by the user.
SLCT FREQ – Select appropriate frequency for approach.	The system notifies the pilot to load the approach frequency for the appropriate NAV receiver. Select the correct frequency for the approach.
SLCT MAG – Select MAGNETIC NAV ANGLE display units.	The system notifies the pilot to set the Nav Angle units on the Avionics Settings Screen to Magnetic.
SLCT NAV – Select NAV on CDI for approach.	The system notifies the pilot to set the CDI to the correct NAV receiver. Set the CDI to the correct NAV receiver.
SLCT NON-MAG – Select alternate NAV ANGLE display units.	The system notifies the pilot to set the Nav Angle units on the Avionics Settings Screen to True.
STEEP TURN – Steep turn ahead.	A steep turn is 15 seconds ahead. Prepare to turn.
STRMSCP FAIL – Stormscope has failed.	Stormscope has failed. The G1000 System should be serviced.
SVT DISABLED – Out of available terrain region.	Synthetic Vision is disabled because the aircraft is not within the boundaries of the installed terrain database.
SVT DISABLED – Terrain DB resolution too low.	Synthetic Vision is disabled because a terrain database of sufficient resolution (9 arc-second or better) is not currently installed.
SW MISMATCH – GDU software version mismatch. Xtalk is off.	The MFD and PFD have different software versions installed. The G1000 system should be serviced.
TIMER EXPIRD – Timer has expired.	The system notifies the pilot that the timer has expired.

Message Advisory	Comments
TRAFFIC FAIL – Traffic device has failed.	The G1000 is no longer receiving data from the traffic system. The traffic device should be serviced.
UNABLE V WPT – Can't reach current vertical waypoint.	The current vertical waypoint can not be reached within the maximum flight path angle and vertical speed constraints. The system automatically transitions to the next vertical waypoint.
VNV – Unavailable. Excessive crosstrack error.	The current crosstrack exceeds the limit, causing vertical deviation to go invalid.
VNV – Unavailable. Excessive track angle error.	The current track angle error exceeds the limit, causing the vertical deviation to go invalid.
VNV – Unavailable. Parallel course selected.	A parallel course has been selected, causing the vertical deviation to go invalid.
VNV – Unavailable. Unsupported leg type in flight plan.	The lateral flight plan contains a procedure turn, vector, or other unsupported leg type prior to the active vertical waypoint. This prevents vertical guidance to the active vertical waypoint.
WPT ARRIVAL – Arriving at waypoint -[xxxx]	Arriving at waypoint [xxxx], where [xxxx] is the waypoint name.
WX ALERT – Possible severe weather ahead.	The GWX 68/GWX 70 indicates severe weather within ± 10 degrees of the aircraft heading at a range of 80 to 320 nm.
XPDR1 ADS-B FAIL – XPDR1 unable to transmit ADS-B messages.	ADS-B is inoperative. Other transponder functions may be available. Transponder should be serviced when possible. (GTX 33 with Extended Squitter only.)
XPDR1 CONFIG – XPDR1 config error. Config service req'd.	The transponder configuration settings do not match those of backup configuration memory. The G1000 system should be serviced.

Message Advisory	Comments
XPDR1 SRVC – XPDR1 needs service. Return unit for repair.	The #1 transponder should be serviced when possible.
XPDR1 FAIL – XPDR1 is inoperative.	There is no communication with the #1 transponder.
XTALK ERROR – A flight display crosstalk error has occurred.	The MFD and PFD are not communicating with each other. The G1000 system should be serviced.

FLIGHT PLAN IMPORT/EXPORT MESSAGES

In some circumstances, some messages may appear in conjunction with others.

Flight Plan Import/Export Results	Description
'Flight plan successfully imported.'	A flight plan file stored on the SD card was successfully imported as a stored flight plan.
'File contained user waypoints only. User waypoints imported successfully. No stored flight plan data was modified.'	The file stored on the SD card did not contain a flight plan, only user waypoints. These waypoints have been saved to the system user waypoints. No flight plans stored in the system have been modified.
'No flight plan files found to import.'	The SD card contains no flight plan data.
'Flight plan import failed.'	Flight plan data was not successfully imported from the SD card.
'Flight plan partially imported.'	Some flight plan waypoints were successfully imported from the SD card, however others had errors and were not imported. A partial stored flight plan now exists in the system.
'File contained user waypoints only.'	The file stored on the SD card did not contain a flight plan, only user waypoints. One or more of these waypoints did not import successfully.

Flight Plan Import/Export Results	Description
'Too many points. Flight plan truncated.'	The flight plan on the SD card contains more waypoints than the system can support. The flight plan was imported with as many waypoints as possible.
'Some waypoints not loaded. Waypoints locked.'	The flight plan on the SD card contains one or more waypoints that the system cannot find in the navigation database. The flight plan has been imported, but must be edited within the system before it can be activated for use.
'User waypoint database full. Not all loaded.'	The flight plan file on the SD card contains user waypoints. The quantity of stored user waypoints has exceeded system capacity, therefore not all the user waypoints on the SD card have been imported. Any flight plan user waypoints that were not imported are locked in the flight plan. The flight plan must be edited within the system before it can be activated for use.
'One or more user waypoints renamed.'	One or more imported user waypoints were renamed when imported due to naming conflicts with waypoints already existing in the system.
'Flight plan successfully exported.'	The stored flight plan was successfully exported to the SD card.
'Flight plan export failed.'	The stored flight plan was not successfully exported to the SD card. The SD card may not have sufficient available memory or the card may have been removed prematurely.

Flight Instruments

EIS

Nav/Com/XPDR/Audio

AFCS

GPS Nav

Flight Planning

Procedures

Hazard Avoidance

Additional Features

Abnormal Operation

Annun/Alerts

Appendix

Index

Flight Instruments

EIS

Nav/Com/XPDR/Audio

AFCs

GPS Nav

Flight Planning

Procedures

Hazard Avoidance

Additional Features

Abnormal Operation

Annun/Alerts

Appendix

Index

Blank Page

APPENDIX

PFD SOFTKEY MAP

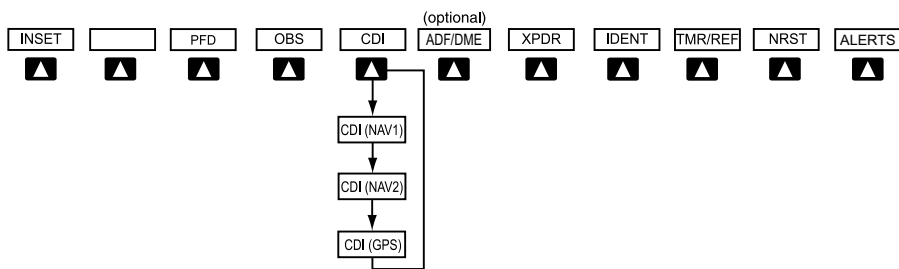

Top Level PFD Softkeys

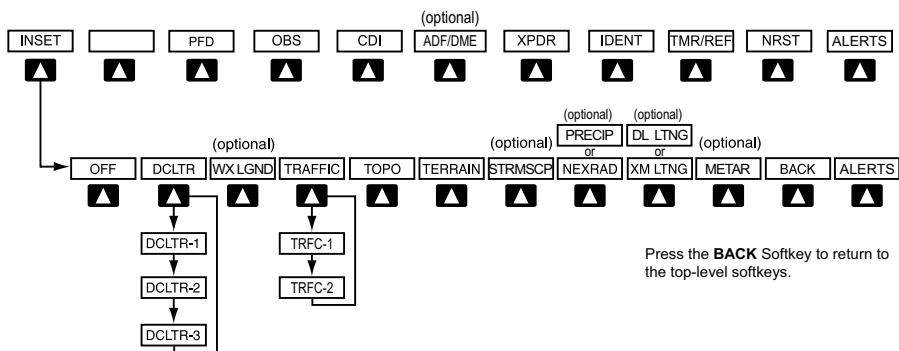

Inset Map Softkeys

INSET		Displays Inset Map in PFD lower left corner
	OFF	Removes Inset Map
	DCLTR (3)	Selects desired amount of map detail; cycles through declutter levels: DCLTR (No Declutter): All map features visible DCLTR-1: Declutters land data DCLTR-2: Declutters land and SUA data DCLTR-3: Removes everything except the active flight plan
	WX LGND	Displays icon and age on the Inset Map for the selected weather products (optional)

Flight Instruments	TRAFFIC	Cycles through traffic display options: TRFC-1: Traffic displayed on inset map TRFC-2: Traffic Map Page is displayed in the inset map window
EIS	TOPO	Displays topographical data (e.g., coastlines, terrain, rivers, lakes) and elevation scale on Inset Map
Nav/Com/XPDR/Audio	TERRAIN	Displays terrain information on Inset Map
AFC	STRMSCP	Select to display the optional onboard lightning detection system lightning data on the Inset Map (within a 200 nm radius of the aircraft)
GPS Nav	NEXRAD or PRECIP	Displays NEXRAD weather and coverage information on the Inset Map (optional) Displays Worldwide Weather precipitation on the Inset Map (optional)
Flight Planning	XM LTNG or DL LTNG	Displays XM lightning information on the Inset Map (optional) Displays Worldwide Weather lightning information on the Inset Map (optional)
Procedures	METAR	Displays METAR flags on airport symbols shown on the Inset Map (optional)

Additional Features

Abnormal Operation

Annun/Alerts

Appendix

Index

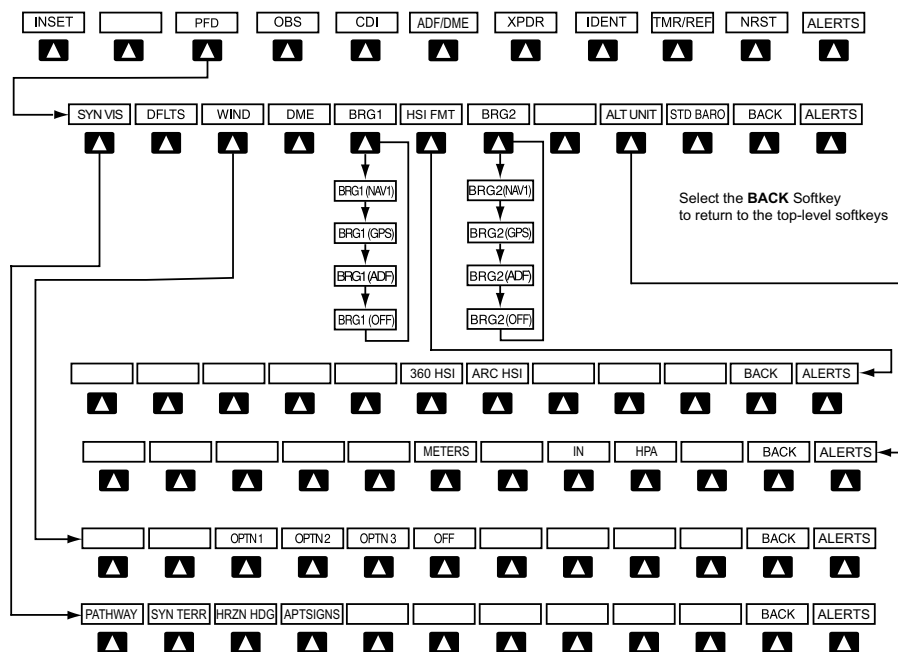

PFD Configuration Softkeys

PFD			Displays second-level softkeys for additional PFD configurations
	SYN VIS		Displays the softkeys for enabling or disabling Synthetic Vision features
		PATHWAY	Displays rectangular boxes representing the horizontal and vertical flight path of the active flight plan
		SYN TERR	Enables synthetic terrain depiction
		HRZN HDG	Displays compass heading along the Zero-Pitch line
		APTSIGNS	Displays position markers for airports within approximately 15 nm of the current aircraft position. Airport identifiers are displayed when the airport is within approximately 9 nm.

Flight Instruments	DFLTS		Resets PFD to default settings, including changing units to standard
EIS	WIND		Displays softkeys to select wind data parameters
Nav/Com/XPDR/Audio		OPTN 1	Wind direction arrows with headwind and crosswind components
AFCs		OPTN 2	Wind direction arrow and speed
GPS Nav		OPTN 3	Wind direction arrow with headwind/tailwind and crosswind components
Flight Planning		OFF	Information not displayed
Procedures	DME		Displays the DME Information Window
Hazard Avoidance	BRG1		Cycles the Bearing 1 Information Window through NAV1 or GPS/waypoint identifier and GPS-derived distance information, and ADF/frequency.
Additional Features	HSI FRMT		Displays the HSI formatting softkeys
Abnormal Operation		360 HSI	Displays the HSI in a 360 degree format
Annun/Alerts		ARC HSI	Displays the HSI in an arc format
Appendix	BRG2		Cycles the Bearing 2 Information Window through NAV2 or GPS/waypoint identifier and GPS-derived distance information, and ADF/frequency.
Index	ALT UNIT		Displays softkeys for setting the altimeter and BARO settings to metric units
		METERS	When enabled, displays altimeter in meters
		IN	Press to display the BARO setting as inches of mercury
		HPA	Press to display the BARO setting as hectopascals
	STD BARO		Sets barometric pressure to 29.92 in Hg (1013 hPa)

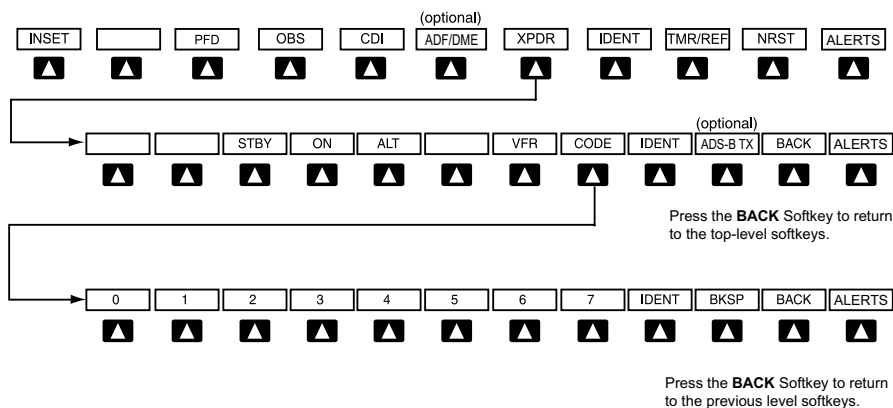

Transponder Softkeys

XPDR		Displays transponder mode selection softkeys
	STBY	Selects Standby Mode (transponder does not reply to any interrogations)
	ON	Selects Mode A (transponder replies to interrogations)
	ALT	White (On-Ground) - Transponder does not allow Mode A or Mode C replies to interrogations, , but it does permit acquisition and extended squitters including ADS-B out (if equipped), and replies to discretely addressed Mode S interrogations. Green (Airborne) - Transponder generates Mode A, Mode C, and Mode S replies to interrogations, as well as transmissions of acquisition and extended squitters including ADS-B out (if equipped).
	VFR	Automatically enters the VFR code (1200 in the U.S.A. only)
	CODE	Displays transponder code selection softkeys 0-7
		0 — 7 Use numbers to enter code

		BKSP	Removes numbers entered, one at a time
IDENT			Activates the Special Position Identification (SPI) pulse for 18 seconds, identifying the transponder return on the ATC screen
	ADS-B TX		Activates/deactivates transmission of the aircraft's three-dimensional position and aircraft heading for reception by ADS-B systems.
TMR/REF			Displays Timer/References Window
NRST			Displays Nearest Airports Window
ALERTS			Displays Alerts Window

MFD SOFTKEY MAP

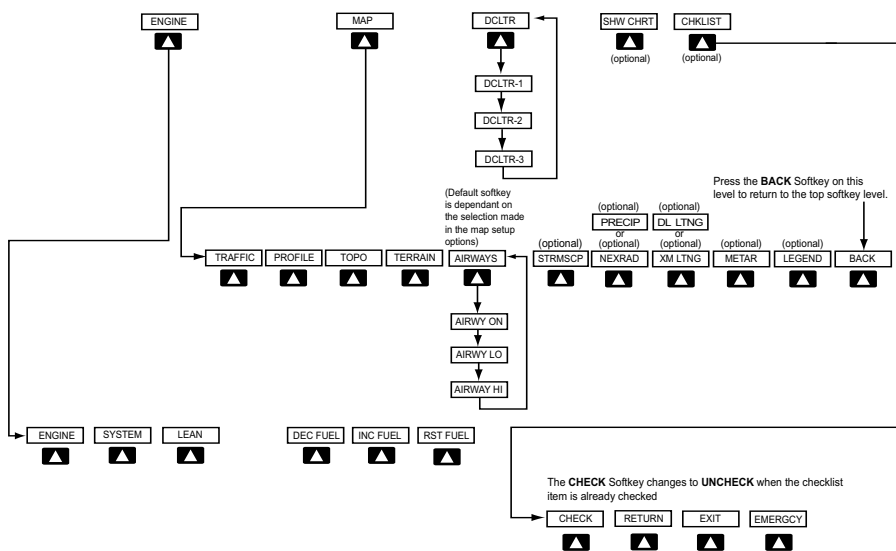

MFD Softkeys

ENGINE		Displays EIS-Engine Page
	SYSTEM	Displays the Engine System Display
	FUEL	Displays the fuel softkeys

		DEC FUEL	Press to decrease remaining fuel quantity in 1-gallon increments	Flight Instruments
		INC FUEL	Press to increase remaining fuel quantity in 1-gallon increments	EIS
		RST FUEL	Press to reset fuel to full	Nav/Com/XPDR/Audio
MAP			Enables second-level Navigation Map softkeys	AFCS
	TRAFFIC		Displays traffic information on Navigation Map	GPS Nav
	PROFILE		Displays/removes Profile View on Navigation Map Page	Flight Planning
	TOPO		Displays topographical data (e.g., coastlines, terrain, rivers, lakes) and elevation scale on Navigation Map	Procedures
	TERRAIN		Displays terrain information on Navigation Map	Hazard Avoidance
	AIRWAYS		Displays airways on the map; cycles through the following: AIRWAYS: No airways are displayed AIRWY ON: All airways are displayed AIRWY LO: Only low altitude airways are displayed AIRWY HI: Only high altitude airways are displayed	Additional Features
	STRMSCP		Displays onboard lightning detection system weather and coverage information on Navigation Map (optional)	Abnormal Operation
	NEXRAD or PRECIP		Displays NEXRAD weather and coverage information on the Navigation Map (optional) Displays Worldwide Weather precipitation on the Navigation Map (optional)	Annun/Alerts

Flight Instruments

EIS

Nav/Com/XPDR/Audio

AFCS

GPS Nav

Flight Planning

Procedures

Hazard Avoidance

Additional Features

Abnormal Operation

Annun/Alerts

Appendix

Index

Flight Instruments	XM LTNG or DL LTNG		Displays XM lightning information on the Navigation Map (optional) Displays Worldwide Weather lightning information on the Navigation Map (optional)
EIS			
Nav/Com/XPDR/Audio	METAR		Displays METAR flags on airport symbols shown on the Inset Map (optional)
AFC	LEGEND		Displays the legend for the selected weather products. Available only when NEXRAD, XM LTNG, and/or METAR softkeys are selected.
GPS Nav	BACK		Returns to top-level softkeys
Flight Planning	DCLTR (3)		Selects desired amount of map detail; cycles through declutter levels: DCLTR (No Declutter): All map features visible DCLTR-1: Declutters land data DCLTR-2: Declutters land and SUA data DCLTR-3: Removes everything except the active flight plan
Procedures	SHW CHRT		When available, displays optional airport and terminal procedure charts
Hazard Avoidance	CHKLIST		When available, displays optional checklists
Additional Features			
Abnormal Operation			

LOADING UPDATED DATABASES



CAUTION: Never disconnect power to the system when loading a database. Power interruption during the database loading process could result in maintenance being required to reboot the system.



NOTE: When loading database updates, the 'DB Mismatch' message will be displayed until database synchronization is complete, followed by turning system power off, then on. Synchronization can be monitored on the AUX-SYSTEM STATUS Page.

In some cases it may be necessary to obtain an unlock code from Garmin in order to make the database product functional. It may also be necessary to have the system configured by a Garmin authorized service facility in order to use some database features.

If an error occurs during synchronization, an error message will be displayed, followed by the affected display in the Sync Status section of the Database Window. If synchronization completes on one display, but an error occurs on another, the error message will be displayed with the affected displays listed after it. When an error message is displayed, the problem must be corrected before synchronization can be completed. A power cycle is required to restart synchronization when 'Card Full' or 'Err' is shown.

Error Message	Description
Canceled	Database synchronization has been canceled by removing the bottom SD card in display being updated
Card Full	SD card does not contain sufficient memory
Err	Displayed for all other errors that may cause the synchronization process to be halted
Timeout	System timed-out prior to the database transfer completing

Updating the active navigation database (not using the Dual Navigation Database or Automatic Database Synchronization Features)

- 1) Go to www.flygarmin.com or www.jeppesen.com. Download the applicable software and install the navigation database on a blank SD card.
- 2) With the system OFF, insert the SD card containing the new navigation database version into the top card slot of the display (label of SD card facing left).
- 3) Turn the system ON. A prompt similar to the following is displayed in the upper left corner of the display:
- 4) Press the **NO** Softkey to proceed to loading only the active database.
- 5) A prompt similar to the following is displayed, press the **YES** Softkey to update the active navigation database.
- 6) After the update completes, the display starts in normal mode. Do not remove power while the display is starting.

- 7) Turn the system OFF and remove the SD card from the top card slot.
- 8) Repeat steps 2 through 7 for the other display. Remove the SD card when finished.
- 9) Apply power to the system and press the **ENT** Key or the right-most softkey on the MFD to acknowledge the startup screen.
- 10) Turn the large **FMS** Knob to select the AUX Page group on the MFD.
- 11) Turn the small **FMS** Knob to select the System Status Page.
- 12) Press the Display Database Selection Softkey to show active navigation database information for each display.
- 13) Verify the correct navigation database cycle information is shown for each display.
- 14) Remove power from the system.

Loading a standby navigation database

- 1) Go to www.flygarmin.com or www.jepesen.com. Download the applicable software and install the navigation database on a blank SD card.
- 2) With the system OFF, insert the SD card containing the new navigation database version into the top card slot of the display.
- 3) Verify that an SD card is inserted in the bottom slot of each display.
- 4) Turn the system ON.
- 5) Press the **YES** softkey. The navigation database is copied to the SD card in the bottom of the display.
- 6) After the navigation database files are copied to the bottom SD card, the display will appear.
- 7) As instructed on the display, press any key to continue.
- 8) Press any key to continue.
- 9) Press the **NO** Softkey. The display now starts in normal mode. Since the database effective date is not yet valid, it should not be loaded as the active database. The display now starts in normal mode. Do not remove power while the display is starting.
- 10) Turn the system OFF and remove the SD card from the top card slot.
- 11) Repeat steps 2 through 10 for the other display.

- 12) Apply power to the system and press the **ENT** Key on the MFD display to acknowledge the startup screen.
- 13) Turn the large **FMS** Knob to select the AUX Page group on the MFD.
- 14) Turn the small **FMS** Knob to select the System Status Page.
- 15) Press the Display Database Selection Softkey to show standby navigation database information for each display.
- 16) Verify the correct standby navigation database cycle information is shown for each display.
- 17) Remove power from the system.

Updating Basemap, SafeTaxi, Obstacle, and Airport Directory

- 1) With the system OFF, remove the Garmin SD Cards from the bottom SD card slot of each flight display unit or from one display only for automatic synchronization to the other card(s).
- 2) Go to www.flygarmin.com. Install the databases on the Garmin SD card for each display, or to one display only for automatic synchronization to the other card(s).
- 3) Put the removed Garmin SD Card(s) back in the bottom SD card slot(s).
- 4) Turn the system ON.
- 5) During MFD power-up, check the MFD Power-Up screen and make sure that the database is initialized and shown on the database information.
- 6) Press the ENT Key on MFD display to acknowledge the startup screen.
- 7) Turn the large **FMS** Knob to select the AUX Page group on the MFD.
- 8) Turn the small **FMS** Knob to select the System Status Page.
- 9) Press the Display Database Selection Softkey to show database information for each display.
- 10) Verify the correct database cycle information is shown for each display.
- 11) Remove power from the system.

Updating Terrain, Chartview and Flitecharts Databases

- 1) With the system OFF, remove the Garmin SD Cards from the bottom SD card slot of each flight display unit.

- 2) Go to www.flygarmin.com or www.jeppesen.com (for ChartView only) and install the databases on the Garmin SD card for each display. (*The FliteCharts or ChartView database must only be installed on the MFD SD Card*).
- 3) Put the Garmin SD Cards back in the bottom SD card slots of each flight display unit.
- 4) Turn the system ON.
- 5) During MFD power-up, check the MFD Power-Up screen and make sure that the database is initialized and shown on the database information.
- 6) Press the ENT Key on MFD display to acknowledge the startup screen.
- 7) Turn the large **FMS** Knob to select the AUX Page group on the MFD.
- 8) Turn the small **FMS** Knob to select the System Status Page.
- 9) Press the Display Database Selection Softkey to show database information for each display.
- 10) Verify the correct database cycle information is shown for each display.
- 11) Remove power from the system.

Magnetic Field Variation Database Update

A copy of the current magnetic field variation database (MV DB) is included with the navigation database. At startup, the system compares this version of the MV DB with that presently being used by the AHRs (GRS). If the system determines the MV DB needs to be updated, a prompt is displayed on the Navigation Map Page.

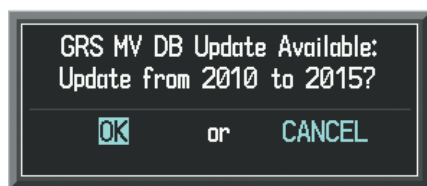

GRS Magnetic Field Variation Database Update Prompt

Loading the magnetic field variation database update:

- 1) With 'OK' highlighted, as shown in the previous figure, press the **ENT** Key on the MFD. A progress monitor is displayed as shown in the following figure.

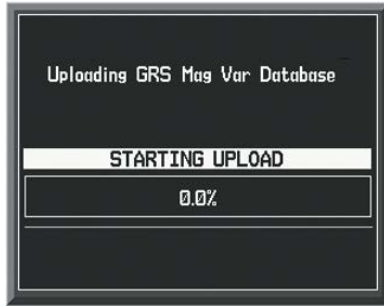

Uploading Database to GRS1

- 2) When the upload is complete the system is ready for use.

- Flight Instruments
- EIS
- Nav/Com/XPDR/Audio
- AFCs
- GPS Nav
- Flight Planning
- Procedures
- Hazard Avoidance
- Additional Features
- Abnormal Operation
- Annun/Alerts
- Appendix
- Index

Blank Page

A

Access Code 48
 Activate a flight plan 18
 Active Channel 83
 Active database 149
 AC-U-KWIK® 82
 ADF 9, 10, 104, 144
 ADS-B 146
 Advisory alerts 109
 AHRS 121, 127, 130
 AIRMET 57
 Airport Directory 82
 Airport Signs 79
 Airways 147
 Antenna Stabilization 70
 Antenna Tilt 68
 AOPA Airport Directory 82
 Audio panel controls
 NAV1, NAV2 10
 Auxiliary video 97

B

Barometric Altitude Minimums 3
 Barometric pressure 144
 Bearing Line 68, 70
 Bluetooth 101, 102

C

CDI 1, 10
 Cell 43, 44
 Cell mode 44
 Channel Presets 84
 ChartView 80, 81
 Checklists 99–100
 CLD TOP Softkey 56
 Clearance player 11
 Clearance Recorder 11

Code selection softkeys 10
 COM 10, 11, 103
 Connex Weather 47, 48, 50, 51, 52,
 54, 55, 56, 57, 58, 59

D

Database Synchronization 149
 DB Mismatch 148
 DCLTR Softkey 80
 Dead Reckoning 104
 DEC FUEL softkey 8
 Declutter 104, 141, 148
 Direct-to 17
 DME 9, 10
 DR mode 104, 105, 106

E

Edit a flight plan 33
 Electronic checklists 99, 100
 Emergency checklist 100
 Enable Terrain 78
 Endurance 7

F

Flight Director 13
 Flight ID 9
 Flight path marker 79
 Flight plan import/export messages 138
 Flight Stream 101
 FliteCharts® 80, 81
 Frequency Transfer 10
 Fuel remaining 7
 Fuel used 7

G

Gain 69
 Garmin Connex 47, 48, 53, 54
 Garmin Connex Weather 49

Garmin ESPT™ 96
Garmin Pilot 101

H

Horizon heading 79
Horizontal Scan 68

I

Inhibit Terrain 78
Inset Map 141, 142
IOI 111
Iridium 85, 88
Iridium Satellite Network 85

J

Jeppesen 81

L

Lightning 43, 44, 49, 142

M

Magnetic Field Variation Database 152
Map panning 45
Message advisories 120
METAR 45, 49, 57, 58, 142
Minimums 112
MKR/MUTE 11
Mode selection softkeys 10
Multi Function Display (MFD)
Softkeys 146

N

NAV 10
NAV1 1, 10
NAV2 1, 10
Navigation database 19, 20
NEXRAD 45, 142, 147
NEXRAD Softkey 55

O

OBS 2
Obstacles 124, 131
Overspeed Protection 14

P

Pairing 101
Pathways 79
Pilot Weather Report (PIREP) 49
PIREP 58
Power-up page 99
Precipitation 49
Predefined Message 91, 92

R

Register 48
Reversionary mode 103
ROC 111

S

SafeTaxi® 80
SBAS 38
Sector Scan 70
Secure Digital (SD) card 99
SIGMET 49, 57
SiriusXM Lightning 142, 148
SiriusXM Weather 45
SMS 84
STAB 70
Standby 67
Standby Navigation Database 150,
151, 152
Store Flight Plan 33
Strike 43
Strike mode 44
SVT 79, 136
Synchronization 149

Synthetic Vision Technology 79
 System ID 48

T

TA 112
 TAF 45, 57
 TAS 72, 112, 121
 Telephone 84, 85, 86, 87, 89, 90, 92
 Terminal Aerodrome Forecast (TAF) 49
 Terrain 76, 124, 142, 147
 Terrain-SVS 76, 77, 78
 Text Message 89, 90, 91, 92
 Tilt line 68
 Topographical data 147
 Topographical Data 142
 Traffic 43, 71, 147
 Traffic advisory 71
 Traffic Advisory 112
 Traffic map page 71, 72, 76
 Transponder 9, 10, 145, 146

U

Universal Access Transceiver (UAT) 72
 USP 16

V

Vertical speed guidance 20
 Vertical track 112
 Video 97
 VNV 17, 104
 Vspeed 2

W

WAAS 131
 WATCH® 70
 Waypoint Selection Submenu 27, 28
 Weather Attenuated Color Highlight 70
 Weather data link page 45

Weather Radar 66
 Wind data 144
 Winds Aloft 49, 58
 WIND Softkey 58, 64
 Worldwide Weather 47, 52, 55, 142,
 147, 148

 Flight
 Instruments

EIS

 Nav/Com/
 XPDR/Audio

AFCS

GPS Nav

 Flight
 Planning

Procedures

 Hazard
 Avoidance

 Additional
 Features

 Abnormal
 Operation

 Annun/
 Alerts

Appendix

Index

- Flight Instruments
- EIS
- Nav/Com/XPDR/Audio
- AFCs
- GPS Nav
- Flight Planning
- Procedures
- Hazard Avoidance
- Additional Features
- Abnormal Operation
- Annun/Alerts
- Appendix
- Index

Blank Page



GARMIN



Garmin International, Inc.
1200 East 151st Street
Olathe, KS 66062, U.S.A.
p: 913.397.8200 f: 913.397.8282
Aircraft On Ground (AOG) Hotline: 913.397.0836
Aviation Dealer Technical Support: 888.606.5482

Garmin AT, Inc.
2345 Turner Road SE
Salem, OR 97302, U.S.A.
p: 503.581.8101 f: 503.364.2138

Garmin (Europe) Ltd.
Liberty House, Hounsdown Business Park
Southampton, Hampshire SO40 9LR U.K.
Tel: +44 (0) 238 052 4000
Fax: +44 (0) 238 052 4004
Aviation Support: +44 (0) 370 850 1243

Garmin Corporation
No. 68, Zhangshu 2nd Road
Xizhi District, New Taipei City, Taiwan
p: 34-93-357-2608 f: 34-93-429-4484

www.garmin.com

