

# **GMR 21/41**

*marine radar*

*installation instructions*



Garmin International, Inc.  
1200 East 151<sup>st</sup> Street,  
Olathe, Kansas 66062, U.S.A.  
Tel. 913/397.8200 or 800/800.1020  
Fax 913/397.8282

Garmin (Europe) Ltd.  
Unit 5, The Quadrangle, Abbey Park  
Industrial Estate, Romsey, SO51 9DL, U.K.  
Tel. 44/0870.8501241  
Fax 44/0870.8501251

Garmin Corporation  
No. 68, Jangshu 2<sup>nd</sup> Road  
Shijr, Taipei County, Taiwan  
Tel. 886/2.2642.9199  
Fax 886/2.2642.9099

All rights reserved. Except as expressly provided herein, no part of this manual may be reproduced, copied, transmitted, disseminated, downloaded or stored in any storage medium, for any purpose without the express prior written consent of Garmin. Garmin hereby grants permission to download a single copy of this manual onto a hard drive or other electronic storage medium to be viewed and to print one copy of this manual or of any revision hereto, provided that such electronic or printed copy of this manual must contain the complete text of this copyright notice and provided further that any unauthorized commercial distribution of this manual or any revision hereto is strictly prohibited.

Information in this document is subject to change without notice. Garmin reserves the right to change or improve its products and to make changes in the content without obligation to notify any person or organization of such changes or improvements. Visit the Garmin Web site ([www.garmin.com](http://www.garmin.com)) for current updates and supplemental information concerning the use and operation of this and other Garmin products.

Garmin® is a registered trademark of Garmin Ltd. or its subsidiaries and may not be used without the express permission of Garmin.

---

## WELCOME

Thank you for choosing the Garmin GMR 21/41. The GMR 21/41 utilizes the performance of Garmin radar and provides overlay and color information when combined with a marine multi-function display (MFD).

### Contact Garmin

If you should encounter any difficulty while using your GMR 21/41, or if you have any questions, in the U.S.A. contact Garmin Product Support by phone: 913/397-8200 or 800/800-1020, Monday thru Friday, 8 am to 5 pm Central Time; or go to [www.garmin.com](http://www.garmin.com) and click on **Product Support**. In Europe, contact Garmin (Europe) Ltd. at 44/0870.8501241.

### Product Support Registration

Help us better support you by completing our on-line registration today! Have the serial number of your GMR 21/41 handy, and connect to our Web site ([www.garmin.com](http://www.garmin.com)). Look for the Product Registration link on the Home page. Also, be sure to record your serial number in the area provided on this page.

### Serial Number

Use this area to record the serial number in case it is lost, stolen, needs service, or if you need to contact Product Support. The 8-digit number is located on the bottom of the unit and on the outside of the product box. It is advisable to record this number prior to installation of the scanner. Be sure to keep your original sales receipt in a safe place or attach a photocopy inside the manual.

--	--	--	--	--	--	--	--

Serial Number



**NOTE:** The Garmin GMR 21/41 has no user-serviceable parts. If you encounter a problem with your unit, please take it to an authorized Garmin NMEA dealer or contact Garmin Product Support for repairs.

---

### Packing List

Before installing and getting started with your unit, please check to see that your package includes the following items. **If any parts are missing, please contact your Garmin dealer immediately.**

#### Standard Package:

- GMR 21 or 41 radar unit
- Power—marine network cable
- Installation manual
- Mount kit hardware
- Grommet for marine cable

# INSTALLATION

## Scanner Installation

The following section covers the installation and setup of the GMR 21 (2 kW) and GMR 41 (4 kW) marine radars. The GMR 21 and 41 only operate with components of the Garmin Marine Network, and MFD's (multifunction displays). See your Garmin dealer or the Garmin Web site for more details. To complete the installation, you need the appropriate fasteners, tools, and mounts. These items should be available at most marine dealers. Always wear safety goggles, ear protection, and a dust mask when drilling, cutting, or sanding. When drilling or cutting, always check first to see what is on the other side of the surface. If you experience difficulty with the installation, contact Garmin Product Support or seek the assistance of a professional installer.

### Installation Guidelines

To maximize the performance of the radar, please observe the following installation guidelines:

- An ideal scanner mounting location is high above the ship's keel line with a minimal part of the vessel's structure or rigging blocking the radar beam. Obstructions in the path of the radar beam may cause blind and shadow sectors, or generate false echoes. The higher the installation position, the further the scanner can detect targets.
- Avoid mounting the scanner on the same level as smoke stacks, horizontal spreaders, or crosstrees on a mast. Do not install the scanner near heat sources where it may be subjected to smoke or hot air from smoke stacks or heat from lights.
- The mounting surface or platform should be sturdy enough to support the weight of the scanner (26 lbs), flat as possible, and parallel with the vessel's water line.
- It is recommended that the radar scanner be mounted out of range of personnel (horizontal beam width above head height). When the scanner is transmitting, do not look directly at the antenna at close range, eyes are the most sensitive part of the body to electromagnetic energy. When properly installed and operated, the use of this radar conforms to the requirements of ANSI/IEEE C95.1-1992 Standard for Safety Levels with Respect to Human Exposure to Radio Frequency Electromagnetic Fields.
- A "Compass Safe Distance" must be maintained between the compass and the scanner. The Compass Safe Distance is measured from the center point of the compass to the nearest point on the scanner.

Standard compass = 1 m

Standby Steering and Emergency compasses = 0.6 m

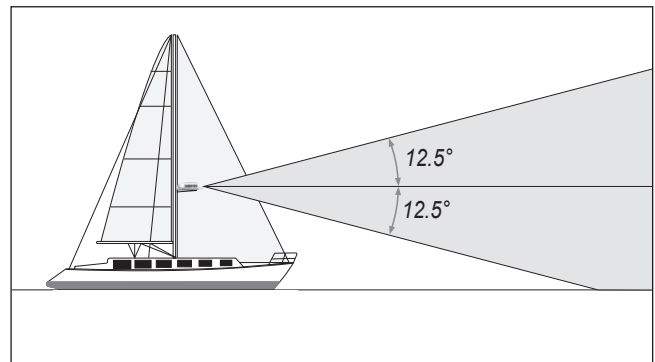
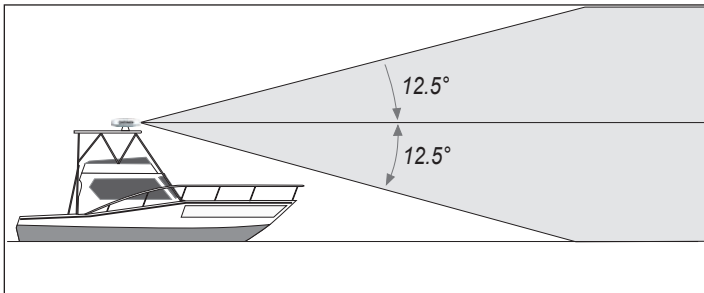

- Mount other electronics and cables more than 2 m (7 ft) from the path of a radar beam. A radar beam can normally be assumed to spread 25° vertically above and below the scanner's radiating element. For vessels with higher bow angles at cruise speed, it may be helpful to lower the angle so the beam points slightly downwards to the waterline while at rest. Shims may be used as necessary.
- Install the scanner away from antennas for other electronics. GPS antennas should be either above or below the radar beam path of the scanner. Mount at least 1 m (3 ft) from any equipment transmitting or cables carrying radio signals, such as VHF radios, cables and antennas. In the case of SSB radios, the distance should be increased to 2 m (7 ft). IEC 60936-1 clause 3-27.1 states maximum distances from the antenna at which RF (radio frequency) levels can be expected.

GMR 21 (100W/m squared = 40 cm [15.75"]) (10W/m squared = 120 cm [47.24"])

GMR 41 (100W/m squared = 60 cm [23.62"]) (10W/m squared = 175 cm [68.90"])

- The radar scanner transmits electromagnetic energy. It is important that the radar is turned off or the DC power input is disconnected when personnel are required to come close to the scanner to perform work on the scanner assembly or associated equipment.

## Installation

The following order of mounting the scanner and attaching the Power/Network cables may vary depending on the installation location and mount used.

### Mounting the Scanner

1. When a suitable mounting location has been determined, verify that the mounting hole locations are aligned fore and aft, then drill four 9.5 mm (0.37") mounting holes referencing Figure 1 below. (This step is not necessary if you are using a pre-drilled Garmin compatible or Raymarine® mount.)
2. Remove the supplied M8 x 30 bolts, flat washers, and spring washers (4 each) from the bottom of the scanner unit. DO NOT remove the outer case bolts. There are no user serviceable parts in the scanner and opening the case may void your warranty.
3. Align the notch and locking ring on the power cable to the power connector. Press the 2-pin power cable to the power connector and the RJ-45 marine network cable to the RJ-45 socket (Figure 2). Turn the power cable locking ring clockwise until it stops. Tighten the RJ-45 locking ring clockwise until it is firmly sealed.
4. The power/network cable may be pressed into one of the five guide grooves molded into the bottom of the scanner case and secured under the cable hold-down plate (Figure 2). Avoid excessive bending or twisting of the cable. See the following "Cable Runs" section for more information.
5. Position the scanner on the mounting surface with the triangular marks on the case aligned to the front of the vessel. Apply a bead of marine sealant around each of the mounting holes on the mounting surface.
6. Fasten the scanner to the mounting surface using the M8 x 1.25 x 30 hex bolts, spring washers, and flat washer and shoulder washers in the order show in Figure 3. The supplied M8 x 1.25 x 30 bolts can be used on mounting thicknesses of 5-10 mm (3/8") (recommended). For surfaces over 10 mm (3/8"), locally supplied longer bolts are needed. **The bolts should be torqued to between 13.7-18.6 Nm (10-14 lb ft).**

### Cable Runs

Route the cable as needed, depending on the type of mount you are using. DO NOT cut the cable! It may be necessary to drill a 31.7 mm (1.25") hole for routing the power/network cable. Garmin provides a rubber cable grommet which may be used to cover the cable installation hole. The grommet does NOT provide a waterproof seal. To waterproof the grommet, apply a marine sealant. Additional cable grommets can be purchased through Garmin or a Garmin dealer.

When installing the power/network cable, observe the following:

- To ensure safety, use the appropriate tie-wraps, fasteners, and sealant to secure the cable along a route and through any bulkhead or deck. Avoid running the cable near moving objects, high-heat sources, or through doorways and bilges.
- Avoid installing the cable next to or parallel to other cables, such as radio antenna lines, or power cables. This is essential to avoid interference to or from other equipment. If this is not possible, shield the cable with metal conduit or a form of EMI shielding.
- Install the power portion of the cable as close to the battery source as possible. A minimum of 10 VDC is required at the 15 m cable connector during radar turn-on and operation. See the table below for the recommended wire gauge between radar cable and battery.

Distance	Gauge
2 meters (6.5 ft)	16 AWG
4 meters (13 ft)	14 AWG
6 meters (19 ft)	12 AWG

Wire Gauge Table

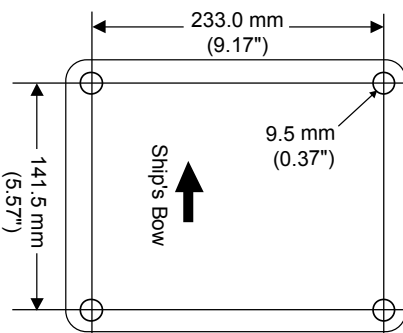

Figure 1

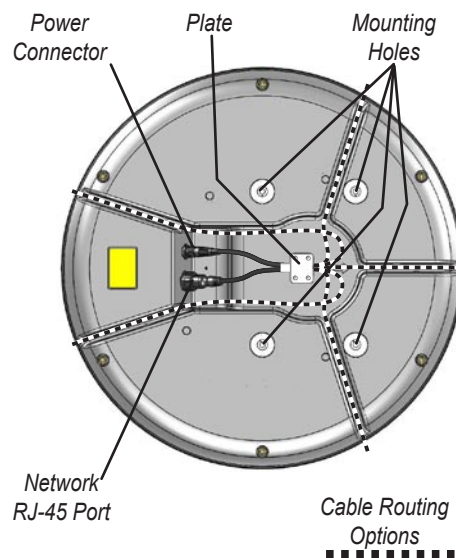

Figure 2

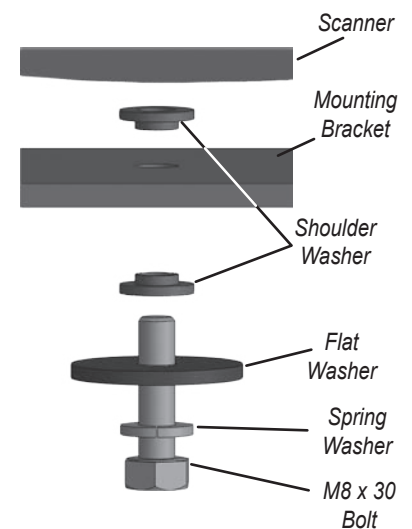
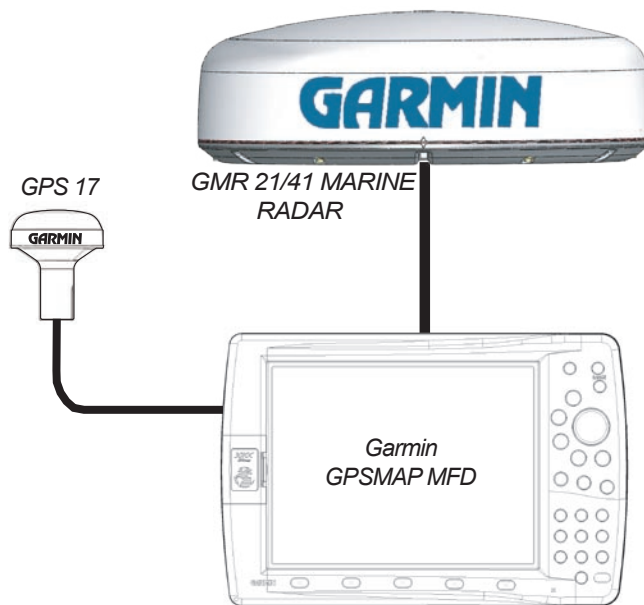

Figure 3

## Final Wiring Connections

### Making the final wiring connections

1. Connect the Black ground (-) wire to the vessel's negative power terminal.
2. Connect the Red power (+) wire (with fuse holder) to the vessel's positive power terminal.
3. For a stand-alone network (MFD and radar only), attach the RJ-45 marine network cable to the RJ-45 socket on the back of the MFD. For an expanded network (MFD, radar, GMS 10), attach the RJ-45 marine network cable to an open RJ-45 socket on the GMS 10 network power expander. Tighten the RJ-45 locking ring clockwise until it is firmly sealed.



**Stand Alone Network**

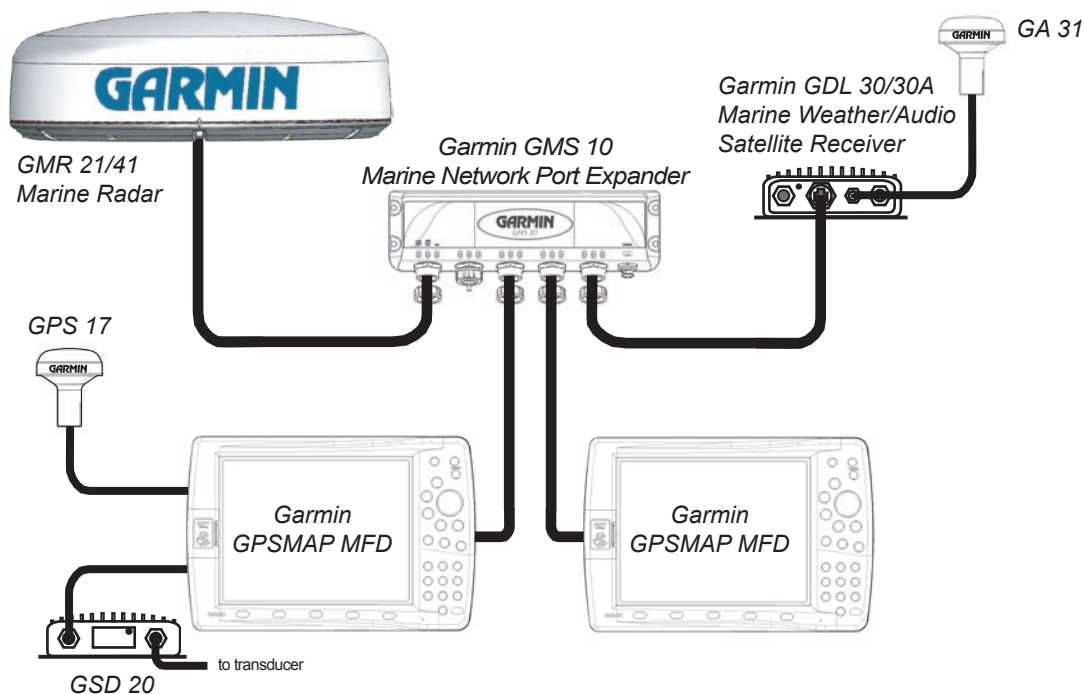

**Expanded Network**

---

## Powering on the System

### To power on the scanner:

1. On the MFD (multi-function display), press the red **Power** key. The scanner is automatically powered on with the MFD. The Welcome Page appears showing the GMR 21 or GMR 41 as a detected network connection.
2. Press **ENTER** when **I Agree** turns yellow, then press **PAGE** until the Radar Page appears.
3. During Standby mode, a countdown appears on the Radar Page and the status bar as the scanner prepares to operate.
4. With the scanner **Ready**, press and hold the **FCTN** key until **Do you want to begin radar transmission?** appears.
5. When safe (personnel are clear of the radar beam path), highlight **Yes**, and press **ENTER**. The scanner spins up and becomes operational.

### Bearing Offset

It may be necessary to adjust the bearing of the radar picture shown on the screen. First, using a magnetic compass, take an optical bearing of a stationary target located within viewable range. Measure the target bearing on the radar. If the bearing deviation is more than +/- 1°, then do the following to correct for the offset:

1. From the Radar Page, press the **ADJ** key to display the Adjustment Menu.
2. From the Adjustment Menu, select **Setup**, and press **ENTER**. Using the **ROCKER**, select the **Advanced** tab.
3. Using the **Rocker**, highlight the **Front of Boat Offset** slider, and press **ENTER**.
4. Press Left on the **Rocker** to adjust to a negative value, or press Right to adjust to a positive value. The preview window changes as you adjust the slider.
5. Once an offset has been determined, press **ENTER** to save, then press **QUIT** to return to the Radar Page. Your new Garmin marine radar is now ready to use! Refer to the *GMR 21/41 Owner's Manual* for details about operating the scanner.

---

## Specifications

Unit Dimensions:	24" (610 mm) D x 8" (205 mm) H
Radar Scanner Weight:	Unit 26 lbs; cable 8.35 lbs
Range Scales (Range Rings):	GMR 41 — 1/8 nm (1/32 nm) to 36 nm (9 nm) GMR 21 — 1/8 nm (1/32 nm) to 24 nm (6 nm)
Power Output:	GMR 21: 2 kW / GMR 41: 4 kW
Power Input Source:	10-35 VDC 28 W
Operating Temperature Range:	-25° C to 70° C, and a relative humidity up to 95% at 35°C
Beamwidth:	Horizontal beamwidth of 3.6° nominal / Vertical beamwidth of 25° nominal
Range:	GMR 21: 24 nm / GMR 41: 36 nm
Wind Velocity:	Wind speed up to 100 Kts
Antenna RPMs:	24 rpm
Range Ring Accuracy:	+/- 1 meter
Bearing Accuracy:	1°
Minimum Range:	35 meters
Range Discrimination:	30 meters
Sensitivity and Tune Controls:	Gain, Sea Clutter, Rain Clutter, and Frequency Tune
Radar/Chart Synchronization:	Overlay mode. Split overlay with standard radar presentation.
Off Center Function:	Look ahead, Auto Shift, and Manual
RF Transmit Frequency:	9410 ± 30 MHz



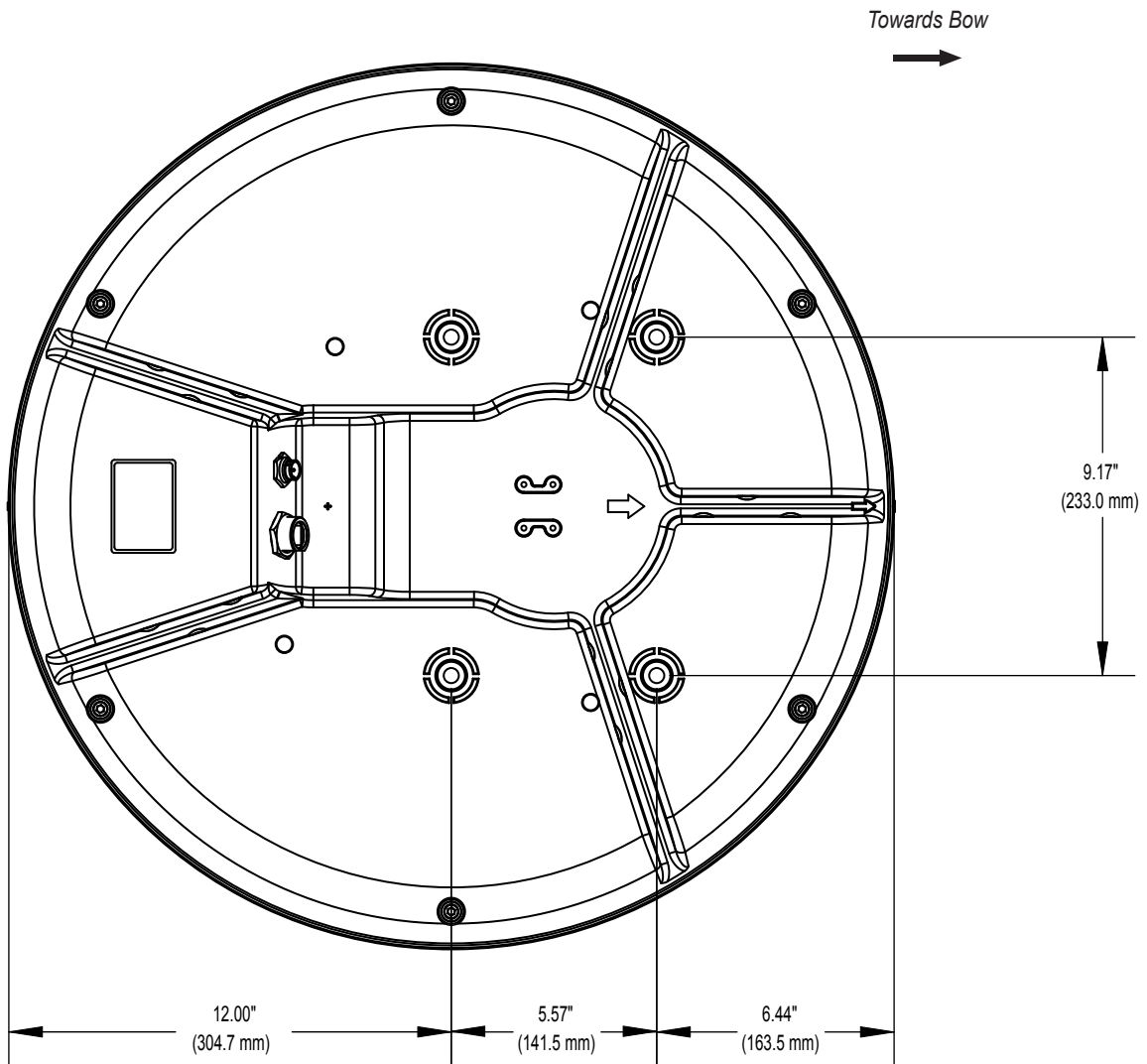
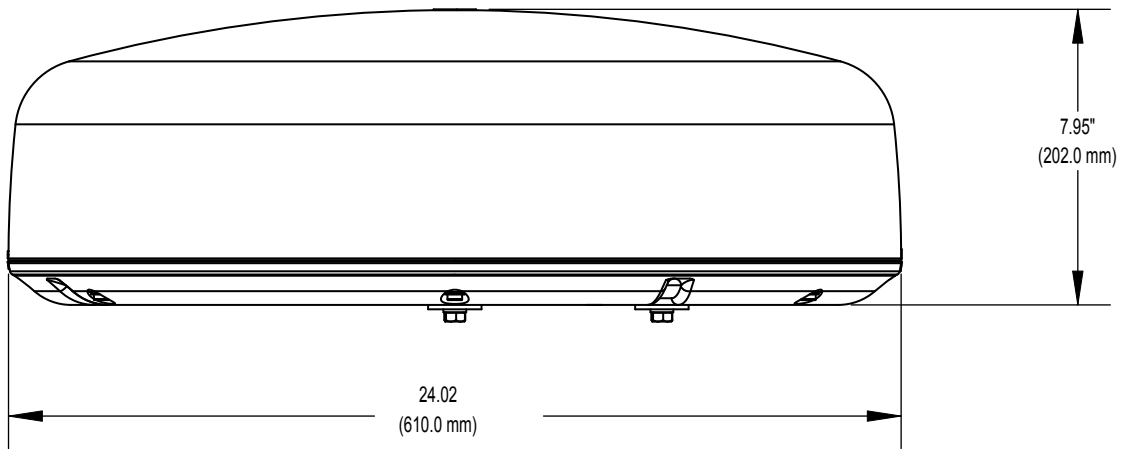



## Warnings and Cautions

**CAUTION:** Use the GMR 21/41 at your own risk. To reduce the risk of unsafe operation, carefully review and understand all aspects of this Installation Manual, and thoroughly practice operation using the simulator mode prior to actual use. When in actual use, carefully compare indications from the GMR 21/41 to all available navigation sources, including the information from other NAVAIDs, visual sightings, charts, etc. For safety, always resolve any discrepancies before continuing navigation.

**CAUTION:** IT IS THE USER'S RESPONSIBILITY TO USE THIS PRODUCT PRUDENTLY. THIS PRODUCT IS INTENDED TO BE USED ONLY AS A NAVIGATIONAL AID AND MUST NOT BE USED FOR ANY PURPOSE REQUIRING PRECISE MEASUREMENT OF DIRECTION, DISTANCE, LOCATION, OR TOPOGRAPHY.

**WARNING:** The radar scanner transmits electromagnetic energy. Ensure that the scanner has been installed according to the recommendations given in this guide, and that all personnel are clear of the scanner before switching to transmit mode.

**WARNING:** This product, its packaging, and its components contain chemicals known to the State of California to cause cancer, birth defects, or reproductive harm. This Notice is being provided in accordance with California's Proposition 65. If you have any questions or would like additional information, please refer to our Web site at <http://www.garmin.com/prop65>.

## FCC Compliance

The GMR 21/41 complies with Part 80 of the FCC rules. It has received a grant of equipment authorization, issued under the authority of the FCC.

This equipment generates, uses, and can radiate radio frequency energy and, if not installed and used in accordance with the instructions, may cause harmful interference to radio communications. However, there is no guarantee that interference will not occur in a particular installation. If this equipment does cause harmful interference to radio or television reception, which can be determined by turning the equipment off and on, the user is encouraged to try to correct the interference by one of the following measures:

- Reorient or relocate the receiving antenna.
- Increase the separation between the equipment and the receiver.
- Connect the equipment into an outlet on a circuit different from that to which the receiver is connected.
- Consult the dealer or an experienced radio/TV technician for help.

---

## Software License Agreement

BY USING THE GMR 21/41, YOU AGREE TO BE BOUND BY THE TERMS AND CONDITIONS OF THE FOLLOWING SOFTWARE LICENSE AGREEMENT. PLEASE READ THIS AGREEMENT CAREFULLY.

Garmin grants you a limited license to use the software embedded in this device (the “Software”) in binary executable form in the normal operation of the product. Title, ownership rights and intellectual property rights in and to the Software remain in Garmin.

You acknowledge that the Software is the property of Garmin and is protected under the United States of America copyright laws and international copyright treaties. You further acknowledge that the structure, organization and code of the Software are valuable trade secrets of Garmin and that the Software in source code form remains a valuable trade secret of Garmin. You agree not to decompile, disassemble, modify, reverse assemble, reverse engineer, or reduce to human readable form the Software or any part thereof or create any derivative works based on the Software. You agree not to export or re-export the Software to any country in violation of the export control laws of the United States of America.

## Limited Warranty

This Garmin product is warranted to be free from defects in materials or workmanship for one year from the date of purchase. Within this period, Garmin will at its sole option repair or replace any components that fail in normal use. Such repairs or replacement will be made at no charge to the customer for parts or labor, provided that the customer shall be responsible for any transportation cost. This warranty does not cover failures due to abuse, misuse, accident or unauthorized alteration or repairs.

THE WARRANTIES AND REMEDIES CONTAINED HEREIN ARE EXCLUSIVE AND IN LIEU OF ALL OTHER WARRANTIES EXPRESS OR IMPLIED OR STATUTORY, INCLUDING ANY LIABILITY ARISING UNDER ANY WARRANTY OF MERCHANTABILITY OR FITNESS FOR A PARTICULAR PURPOSE, STATUTORY OR OTHERWISE. THIS WARRANTY GIVES YOU SPECIFIC LEGAL RIGHTS, WHICH MAY VARY FROM STATE TO STATE.

IN NO EVENT SHALL GARMIN BE LIABLE FOR ANY INCIDENTAL, SPECIAL, INDIRECT OR CONSEQUENTIAL DAMAGES, WHETHER RESULTING FROM THE USE, MISUSE, OR INABILITY TO USE THIS PRODUCT OR FROM DEFECTS IN THE PRODUCT. Some states do not allow the exclusion of incidental or consequential damages, so the above limitations may not apply to you.

Garmin retains the exclusive right to repair or replace the unit or software or offer a full refund of the purchase price at its sole discretion. SUCH REMEDY SHALL BE YOUR SOLE AND EXCLUSIVE REMEDY FOR ANY BREACH OF WARRANTY.

To obtain warranty service, contact your local Garmin authorized dealer or call Garmin Product Support for shipping instructions and an RMA tracking number. The unit should be securely packed with the tracking number clearly written on the outside of the package. The unit should then be sent, freight charges prepaid, to any Garmin warranty service station. A copy of the original sales receipt is required as the proof of purchase for warranty repairs.

Garmin International, Inc.  
1200 E 151st Street, Olathe, Kansas 66062 U.S.A.  
Tel. 913/397.8200  
Fax. 913/397.8282

Garmin (Europe) Ltd.  
Unit 5, The Quadrangle, Abbey Park Industrial Estate, Romsey, SO51 9DL U.K.  
Tel. 44/0870.8501241  
Fax 44/0870.8501251

**Online Auction Purchases:** Products sold through online auctions are not eligible for rebates or other special offers from Garmin. Online auction confirmations are not accepted for warranty verification. To obtain warranty service, an original or copy of the sales receipt from the original retailer is required. Garmin will not replace missing components from any package purchased through an online auction.

**International Purchases:** A separate warranty is provided by international distributors for units purchased outside the United States. This warranty is provided by the local in-country distributor and this distributor provides local service for your unit. Distributor warranties are only valid in the area of intended distribution. Units purchased in the United States or Canada must be returned to the Garmin service center in the United Kingdom, the United States, Canada, or Taiwan for service.

The Garmin GMR 21/41 has no user-serviceable parts. Should you ever encounter a problem with your unit, please take it to an authorized Garmin dealer for repairs.

The GMR 21/41 is fastened shut with screws. Any attempt to open the case to change or modify the unit in any way will void your warranty and may result in permanent damage to the equipment.





© Copyright 2006 Garmin Ltd. or its subsidiaries

Garmin International, Inc.  
1200 E 151st Street, Olathe, Kansas 66062 U.S.A.  
Tel. 913/397.8200  
Fax. 913/397.8282

Garmin (Europe) Ltd.  
Unit 5, The Quadrangle, Abbey Park Industrial Estate, Romsey, SO51 9AQ U.K.  
Tel. 44/0870.8501241  
Fax. 44/0870.8501251

Garmin Corporation  
No. 68, Jangshu 2nd Road, Shijr, Taipei County, Taiwan  
Tel. 886/2.2642.9199  
Fax. 886/2.2642.9099

Part Number 190-00665-02 Rev. A