

# Garmin G5

## Electronic Flight Instrument

### Part 23 AML STC Installation Manual





©2016 - 2021 Garmin International or its subsidiaries  
All Rights Reserved

Except as expressly provided herein, no part of this manual may be reproduced, copied, transmitted, disseminated, downloaded or stored in any storage medium, for any purpose without the express prior written consent of Garmin. Garmin hereby grants permission to download a single copy of this manual and of any revision to this manual onto a hard drive or other electronic storage medium to be viewed and to print one copy of this manual or of any revision hereto, provided such electronic or printed copy of this manual or revision must contain the complete text of this copyright notice and provided further any unauthorized commercial distribution of this manual or any revision hereto is strictly prohibited.

Garmin®, flyGarmin®, are registered trademarks of Garmin International or its subsidiaries. G5™ trademark of Garmin International or its subsidiaries. These trademarks may not be used without the express permission of Garmin.

Garmin International, Inc  
1200 E. 151st Street  
Olathe, KS 66062 USA  
Telephone: 913-397-8200  
Technical Support and Field Service Engineers (Toll Free): 888-606-5482  
[www.flyGarmin.com](http://www.flyGarmin.com)

Garmin (Europe) Ltd.  
Liberty House  
Bull Copse Road  
Hounslow Business Park  
Southampton, SO40 9LR, UK  
Telephone: +44 (0) 23 8052 4000  
Fax: +44 (0) 23 8052 4004  
Aviation Support: +44 (0) 87 0850 1243

Garmin AT, Inc.  
2345 Turner Rd. SE  
Salem, OR 97302 USA  
Telephone: 503-581-8101  
Fax: (503) 364-2138



## RECORD OF REVISIONS

| Revision | Revision Date | Description                                                                                                                                   |
|----------|---------------|-----------------------------------------------------------------------------------------------------------------------------------------------|
| 23       | 06/01/2020    | Reintroduced resistor and diode installation guidance to support field installations, corrected Century 41 autopilot pin configuration.       |
| 24       | 12/02/2020    | Removed discrete components from G5 installation guidance, updated battery pack part number, clarifications in Section 5 Configuration Tables |
| 25       | 02/23/2021    | Added new GigaFlight CAN Wire P/N                                                                                                             |
| 26       | 05/21/2021    | Added MOD 1 for G5 P/N 011-03809-00                                                                                                           |
| 27       | 08/20/2021    | Added new G5 Battery P/N                                                                                                                      |
| 28       | 08/26/2021    | Added GAD 29D, nomenclature change in Section 5 Configuration Tables                                                                          |



## INFORMATION SUBJECT TO EXPORT CONTROL LAWS

This document may contain information which is subject to the Export Administration Regulations (“EAR”) issued by the United States Department of Commerce (15 CFR, Chapter VII, Subchapter C) and which may not be exported, released, or disclosed to foreign nationals inside or outside of the United States without first obtaining an export license. A violation of the EAR may be subject to a penalty of up to 10 years imprisonment and a fine of up to \$1,000,000 under Section 2410 of the Export Administration Act of 1979. Include this notice with any reproduced portion of this document.

## DEFINITIONS OF WARNINGS, CAUTIONS, AND NOTES



### WARNING

*Warnings are used to bring to the installer’s immediate attention not only damage to the equipment but personal injury may occur if the instruction is disregarded.*



### CAUTION

*Cautions are used to alert the individual damage to equipment may result if the procedural step is not followed to the letter.*



### NOTE

*Notes are used to expand and explain the preceding step and provide further understanding of the reason for the particular operation.*



### WARNING

*This product, its packaging, and its components contain chemicals known to the State of California to cause cancer, birth defects, or reproductive harm. This notice is being provided in accordance with California's Proposition 65. If you have any questions or would like additional information, please refer to our web site at [www.garmin.com/prop65](http://www.garmin.com/prop65).*



### WARNING

*Perchlorate Material – special handling may apply, See [www.dtsc.ca.gov/hazardouswaste/perchlorate](http://www.dtsc.ca.gov/hazardouswaste/perchlorate).*



## **BATTERY WARNINGS:**

*If these guidelines are not followed, the lithium-ion battery may experience a shortened life span or may present a risk of damage to the device, fire, chemical burn, electrolyte leak, and/or injury. Do not leave the battery exposed to a heat source or in a high temperature environment. To help prevent damage, store the battery out of direct sunlight.*

*The G5 has an operating temperature range of -4°F to 140°F (-20°C to +60°C). The G5 will prevent operation from the battery when the battery is outside of this temperature range.*

*For maximum battery longevity, store within a temperature range of 32° to 77°F (from 0° to 25°C).*

*Do not use a sharp object to remove the battery.*

*Do not disassemble, puncture, damage, or incinerate the device or battery.*

*Keep the battery away from children.*

*Only replace the battery with the approved replacement from Garmin. Using another battery presents a risk of fire or explosion. To purchase a replacement battery, see you Garmin dealer or the Garmin website.*

*Contact your local waste disposal department to dispose of the device and battery in accordance with applicable local laws and regulations.*



## **CAUTION:**

*The display uses a lens with a special coating that may be sensitive to skin oils, waxes, and abrasive cleaners. **CLEANERS CONTAINING AMMONIA WILL HARM THE ANTI-REFLECTIVE COATING.** It is very important to clean the lens using a clean, lint-free cloth and a cleaner that is specified as safe for anti-reflective coatings. Avoid any chemical cleaners or solvents that can damage plastic components.*



## **CAUTION:**

*The G5 does not contain any user-serviceable parts. Repairs should only be made by an authorized Garmin service center. Unauthorized repairs or modifications could result in permanent damage to the equipment and void both the warranty and the authority to operate this device under FAA, FCC, and other applicable regulations.*



## **NOTE:**

*Use of polarized eyewear may cause the display to appear dim or blank.*



## **NOTE**

*All screen shots used in this document are current at the time of publication. Screen shots are intended to provide visual reference only. All information depicted in screen shots, including software file names, versions, and part numbers, is subject to change and may not be up to date.*



## TABLE OF CONTENTS

| <u>SECTION</u>                                        | <u>PAGE</u> |
|-------------------------------------------------------|-------------|
| 1 GENERAL DESCRIPTION .....                           | 11          |
| 1.1 Introduction .....                                | 11          |
| 1.2 Acronyms and Abbreviations .....                  | 12          |
| 1.3 Reference Documents .....                         | 12          |
| 1.4 STC Permission .....                              | 13          |
| 1.5 Scope .....                                       | 13          |
| 1.6 System Overview .....                             | 14          |
| 1.7 Technical Specifications.....                     | 22          |
| 2 LIMITATIONS .....                                   | 23          |
| 2.1 Installation Limitations.....                     | 23          |
| 2.2 Operational Limitations.....                      | 23          |
| 3 INSTALLATION OVERVIEW .....                         | 24          |
| 3.1 Introduction .....                                | 24          |
| 3.2 Installation Materials.....                       | 24          |
| 3.3 Test Equipment .....                              | 28          |
| 3.4 Installation Considerations.....                  | 28          |
| 4 INSTALLATION PROCEDURES .....                       | 34          |
| 4.1 Mechanical Installation.....                      | 34          |
| 4.2 Electrical Installation .....                     | 72          |
| 4.3 Weight and Balance .....                          | 81          |
| 4.4 Electrical Load Analysis .....                    | 81          |
| 4.5 Electrical Bonding .....                          | 90          |
| 5 SYSTEM INTERCONNECTS .....                          | 97          |
| 5.1 G5 Interconnect Notes .....                       | 98          |
| 5.2 Power and Ground.....                             | 99          |
| 5.3 G5 (ADI) with a GPS Antenna .....                 | 100         |
| 5.4 G5 (ADI) with GPS Position Input .....            | 102         |
| 5.5 G5 (ADI) and GMU 11 with GPS Position Input ..... | 106         |
| 5.6 G5 (ADI or DG), GMU 11 and GPS Antenna.....       | 110         |
| 5.7 G5 (HSI) with VHF Navigator .....                 | 113         |
| 5.8 G5 (HSI) with GPS/VHF Navigator .....             | 116         |
| 5.9 Dual G5 without Navigator .....                   | 122         |
| 5.10 Dual G5 with VHF Navigator.....                  | 125         |
| 5.11 Dual G5 with GPS/VHF Navigator .....             | 129         |
| 5.12 G5 (ADI) with GPS/VHF Navigator .....            | 135         |
| 5.13 G5 (ADI) with VHF Navigator .....                | 141         |
| 5.14 G5 (HSI) with GPS Navigator .....                | 144         |
| 5.15 Dual G5 with GPS Navigator .....                 | 147         |
| 5.16 G5 (ADI) with GPS Navigator .....                | 151         |
| 5.17 G5 (HSI) with Two-Inch GPS Navigator.....        | 154         |
| 5.18 Dual G5 with Two-Inch GPS Navigator.....         | 158         |

|                                                               |            |
|---------------------------------------------------------------|------------|
| 5.19 G5 (ADI) with Two-Inch GPS Navigator.....                | 163        |
| 5.20 G5 Portable Avionics Unit Interface .....                | 167        |
| 5.21 GAD 13 Interface .....                                   | 170        |
| 5.22 Lightning Protection Module (LPM) Wiring Interface ..... | 171        |
| 5.23 GAD 29B Interface to Garmin Autopilots .....             | 172        |
| 5.24 GAD 29B Interface to Non-Garmin Autopilots .....         | 173        |
| <b>6 SYSTEM CONFIGURATION AND CHECKOUT PROCEDURES .....</b>   | <b>185</b> |
| 6.1 Overview .....                                            | 185        |
| 6.2 Mounting, Wiring, and Power Checks.....                   | 185        |
| 6.3 Post-Installation Checkout Procedures.....                | 185        |
| 6.4 Documentation Checks .....                                | 208        |

## FIGURES

| <b>FIGURE</b>                                                                  | <b>PAGE</b> |
|--------------------------------------------------------------------------------|-------------|
| Figure 1-1 G5 Electronic Flight Instrument (Attitude) .....                    | 14          |
| Figure 1-2 G5 Standby Battery .....                                            | 16          |
| Figure 1-3 G5 Electronic Flight Instrument (DG/HSI) .....                      | 17          |
| Figure 1-4 GMU 11 .....                                                        | 20          |
| Figure 1-5 GAD 29/29B.....                                                     | 20          |
| Figure 1-6 Glare Shield Mounted GPS Antenna.....                               | 21          |
| Figure 1-7 GAD 13 .....                                                        | 21          |
| Figure 1-8 GTP 59 (Temperature Probe).....                                     | 21          |
| Figure 3-1 CAN Bus Backbone .....                                              | 30          |
| Figure 3-2 Correct CAN Bus Wiring Example and Node Connections .....           | 31          |
| Figure 3-3 Incorrect CAN Wiring Example .....                                  | 31          |
| Figure 3-4 CAN Bus Termination (011-02887-00) for G5, GMU 11, and GAD 13 ..... | 32          |
| Figure 3-5 CAN Bus Termination for GAD 29/29B .....                            | 32          |
| Figure 3-6 GAD 29B Inline Transformer Mounting Instructions.....               | 33          |
| Figure 4-1 Typical G5 Installations for IFR Approved Aircraft .....            | 35          |
| Figure 4-2 G5 Mounting Ring.....                                               | 36          |
| Figure 4-3 Maximum Misalignment of the G5 in the Lateral Axis .....            | 36          |
| Figure 4-4 Maximum Misalignment of the G5 in the Longitudinal Axis.....        | 37          |
| Figure 4-5 Maximum Misalignment of the G5 in the Vertical Axis .....           | 37          |
| Figure 4-6 G5 Alignment Pin.....                                               | 38          |
| Figure 4-7 G5 Hex Driver Insertion .....                                       | 38          |
| Figure 4-8 G5 Captive Mounting Screw Replacement .....                         | 39          |
| Figure 4-9 Required Vertical Spacing Between G5 Units .....                    | 40          |
| Figure 4-10 Instrument Panel Modification .....                                | 40          |
| Figure 4-11 G5 Adapter Plate .....                                             | 41          |
| Figure 4-12 G5 Adapter Plate Assembly .....                                    | 41          |
| Figure 4-13 G5 Instrument Hole Dimensions.....                                 | 42          |
| Figure 4-14 Clearance for Connections .....                                    | 43          |
| Figure 4-15 Recessed Adapter Plate .....                                       | 43          |
| Figure 4-16 Recessed Adapter Plate Template Reference Holes.....               | 44          |
| Figure 4-17 Single G5 Recessed Adapter Plate Installation.....                 | 45          |
| Figure 4-18 Single G5 Recessed Installation.....                               | 45          |
| Figure 4-19 Dual Vertical G5 Recessed Adapter Plate Installation .....         | 46          |
| Figure 4-20 Dual Vertical G5 Recessed Installation .....                       | 46          |
| Figure 4-21 Dual Horizontal G5 Recessed Installation .....                     | 47          |
| Figure 4-22 Instrument Panel Limitations .....                                 | 48          |
| Figure 4-23 Instrument Panel - View Looking Forward .....                      | 49          |
| Figure 4-24 Instrument Panel - View with Instruments Removed.....              | 49          |
| Figure 4-25 Recessed Adapter Plate Located on Panel.....                       | 50          |

|                                                                                                   |     |
|---------------------------------------------------------------------------------------------------|-----|
| Figure 4-26 Match Drilling Through Panel - Using Adapter Plate as Template.....                   | 50  |
| Figure 4-27 Preliminary Trimming of Adapter Plate.....                                            | 51  |
| Figure 4-28 Adapter Plate Located on Far Side of Instrument Panel.....                            | 51  |
| Figure 4-29 Additional Trimming of Adapter Plate Required.....                                    | 52  |
| Figure 4-30 Trimmed Adapter Plate.....                                                            | 52  |
| Figure 4-31 Adapter Plate Mounting Holes.....                                                     | 53  |
| Figure 4-32 Dual G5 Panel Cutout - Using Match Drilled Holes for Reference.....                   | 53  |
| Figure 4-33 Instrument Panel After Cutout for Dual Vertical G5 Units.....                         | 54  |
| Figure 4-34 Adapter Plate Installed.....                                                          | 54  |
| Figure 4-35 Dual Vertical G5 Units Installed.....                                                 | 55  |
| Figure 4-36 G5 Flush Mount Adapter Plate Printable Template.....                                  | 56  |
| Figure 4-37 GMU 11 Pitch and Roll Requirements.....                                               | 58  |
| Figure 4-38 GMU 11 Heading Alignment Requirements.....                                            | 59  |
| Figure 4-39 GMU 11 Mounting Hardware.....                                                         | 60  |
| Figure 4-40 GAD 29/29B Mounting Hardware.....                                                     | 62  |
| Figure 4-41 GAD 13 Mounting Hardware.....                                                         | 63  |
| Figure 4-42 Glare Shield Mounted GPS Antenna Dimensions (011-04036-10 shown).....                 | 65  |
| Figure 4-43 Glare Shield Mounted GPS Antenna (Screw-mounted Installation Example).....            | 66  |
| Figure 4-44 Glare Shield Mounted GPS Antenna (Hook & Loop Installation Example, BNC similar)..... | 67  |
| Figure 4-45 GTP 59 OAT Probe Dimensions.....                                                      | 68  |
| Figure 4-46 GTP 59 Mounting (Aircraft with Metallic Skin Example).....                            | 69  |
| Figure 4-47 GTP 59 Mounting - Composite Aircraft (Non-conductive Access Panel).....               | 70  |
| Figure 4-48 GTP 59 Mounting - Composite Aircraft (Conductive Access Panel).....                   | 71  |
| Figure 4-49 GAD29(B), GAD13, GMU11 Wiring Harness Connector Assembly.....                         | 77  |
| Figure 4-50 G5 LPM Wiring Harness Connector Assembly.....                                         | 78  |
| Figure 4-51 Shield Termination Methods.....                                                       | 79  |
| Figure 4-52 Ammeter Placement for Current Measurements.....                                       | 84  |
| Figure 4-53 Blank Electrical Load Tabulation Form, Sheet 1 of 2.....                              | 86  |
| Figure 4-54 Blank Electrical Load Tabulation Form, Sheet 2 of 2.....                              | 87  |
| Figure 4-55 Sample Completed Electrical Load Tabulation Form, Sheet 1 of 2.....                   | 88  |
| Figure 4-56 Sample Completed Electrical Load Tabulation Form, Sheet 2 of 2.....                   | 89  |
| Figure 4-57 Nut and Washer Electrical Bonding.....                                                | 90  |
| Figure 4-58 Nut Plate Electrical Bonding.....                                                     | 90  |
| Figure 4-59 Fiberglass Insulation for Carbon Fiber Material.....                                  | 92  |
| Figure 4-60 Aluminum Tape Joint.....                                                              | 92  |
| Figure 4-61 Aluminum Tape Ground Termination.....                                                 | 93  |
| Figure 4-62 GAD 29/29B Aluminum Tape Installation (GAD 13 similar).....                           | 94  |
| Figure 4-63 #10 Terminal Installation on Garmin Backshell.....                                    | 95  |
| Figure 4-64 - Pan Head Screw Ground Stud Buildup.....                                             | 96  |
| Figure 5-1 G5 Interconnect Notes.....                                                             | 98  |
| Figure 5-2 Power and Ground.....                                                                  | 99  |
| Figure 5-3 G5 (ADI) with a GPS Antenna.....                                                       | 100 |
| Figure 5-4 G5 (ADI) with GPS Position Input ADI Configuration.....                                | 102 |
| Figure 5-5 G5 (ADI) and GMU 11 with GPS Position Input.....                                       | 106 |
| Figure 5-6 G5 (ADI or DG), GMU 11 and GPS Antenna.....                                            | 110 |
| Figure 5-7 G5 (HSI) with VHF Navigator.....                                                       | 113 |
| Figure 5-8 G5 (HSI) with GPS/VHF Navigator.....                                                   | 116 |
| Figure 5-9 G5 (HSI) with GPS/VHF Navigator Notes.....                                             | 117 |
| Figure 5-10 Dual G5 without Navigator.....                                                        | 122 |
| Figure 5-11 Dual G5 with VHF Navigator.....                                                       | 125 |
| Figure 5-12 Dual G5 with GPS/VHF Navigator.....                                                   | 129 |
| Figure 5-13 Dual G5 with GPS/VHF Navigator Notes.....                                             | 130 |
| Figure 5-14 G5(ADI) with GPS/VHF Navigator.....                                                   | 135 |
| Figure 5-15 G5 (ADI) with GPS/VHF Navigator Notes.....                                            | 136 |
| Figure 5-16 G5 (ADI) with VHF Navigator.....                                                      | 141 |
| Figure 5-17 G5 (HSI) with GPS Navigator.....                                                      | 144 |





|                                                                                              |     |
|----------------------------------------------------------------------------------------------|-----|
| Figure 5-18 Dual G5 with GPS Navigator .....                                                 | 147 |
| Figure 5-19 G5 (ADI) with GPS Navigator .....                                                | 151 |
| Figure 5-20 G5 (HSI) with GPS Navigator .....                                                | 154 |
| Figure 5-21 Dual G5 with Two-Inch GPS Navigator .....                                        | 158 |
| Figure 5-22 Dual G5 with Two-Inch GPS Navigator Notes.....                                   | 159 |
| Figure 5-23 G5 (ADI) with Two-Inch GPS Navigator .....                                       | 163 |
| Figure 5-24 G5 Portable Avionics Unit Interface.....                                         | 167 |
| Figure 5-25 GAD 13 Interface.....                                                            | 170 |
| Figure 5-26 Lightning Protection Module (LPM) Wiring Interface.....                          | 171 |
| Figure 5-27 GAD 29B Interface to Century Autopilots, Sheet 1 of 2 .....                      | 174 |
| Figure 5-28 GAD 29B Interface to Century Autopilots, Sheet 2 of 2 .....                      | 175 |
| Figure 5-29 GAD 29B Interface to Cessna Autopilots .....                                     | 177 |
| Figure 5-30 GAD 29B Interface to Honeywell Autopilots.....                                   | 179 |
| Figure 5-31 GAD 29B Interface to S-TEC Autopilots.....                                       | 181 |
| Figure 5-32 GAD 29B Interface To Piper Autopilots.....                                       | 183 |
| Figure 6-1 Attitude Calibration Example .....                                                | 191 |
| Figure 6-2 Example of Calibration Equations .....                                            | 191 |
| Figure 6-3 Engine Vibration Test Failure Indication.....                                     | 193 |
| Figure 6-4 ADI display of OAT and TAS (typical values shown) .....                           | 203 |
| Figure 6-5 HSI Display of Crosswind (Typical Values Shown) .....                             | 204 |
| Figure 6-6 Example EMC Source/Victim Matrix.....                                             | 205 |
| Figure 6-7 J51 on the G5 .....                                                               | 210 |
| Figure 6-8 J111 on the GMU 11 .....                                                          | 211 |
| Figure 6-9 J291 on the GAD 29/29B.....                                                       | 213 |
| Figure 6-10 J292 on the GAD 29/29B.....                                                      | 213 |
| Figure 6-11 J131 on the GAD 13 .....                                                         | 215 |
| Figure 6-12 GTP 59 .....                                                                     | 216 |
| Figure 6-13 G5 Outline Drawing .....                                                         | 217 |
| Figure 6-14 G5 Installation Drawing .....                                                    | 218 |
| Figure 6-15 G5 Panel Cutout Measurements (Not to Scale) .....                                | 219 |
| Figure 6-16 GAD 29/29B Outline Drawing.....                                                  | 220 |
| Figure 6-17 GAD 29/29B Install Breakdown .....                                               | 221 |
| Figure 6-18 GMU 11 Outline Drawing.....                                                      | 222 |
| Figure 6-19 GMU 11 Install Breakdown.....                                                    | 223 |
| Figure 6-20 GAD 13 Outline Drawing .....                                                     | 224 |
| Figure 6-21 GAD 13 Install Breakdown .....                                                   | 225 |
| Figure 6-22 GTP 59 Outline Drawing.....                                                      | 226 |
| Figure 6-23 GTP 59 Install Breakdown.....                                                    | 226 |
| Figure 6-24 G5 Connector Kit Assembly with LPM (011-03002-20).....                           | 227 |
| Figure 6-25 Magnetic Interference Test Harness .....                                         | 229 |
| Figure 6-26 GMU 11 Overbraid Installation .....                                              | 233 |
| Figure 6-27 GMU 11 Overbraid Termination .....                                               | 234 |
| Figure 6-28 Zoning for Wingtips on Aircraft Not Limited to VFR Operation.....                | 259 |
| Figure 6-29 Zoning for Wingtips on Aircraft Limited to VFR Operations .....                  | 262 |
| Figure 6-30 Zoning for Wings Affected by Landing Gear .....                                  | 263 |
| Figure 6-31 Zoning for a Single Propeller (Low- or High-Wing).....                           | 264 |
| Figure 6-32 Zoning for a Low- or High-Wing Canard with a Rear-Mounted Propeller .....        | 265 |
| Figure 6-33 Zoning for a Low- or High-Wing Aircraft with a Curved Lower Fuselage .....       | 266 |
| Figure 6-34 Zoning for a Single, Rear-Mounted Prop above Fuselage.....                       | 267 |
| Figure 6-35 Zoning for Front-Mounted Twin Propellers (Low- or High-Wing) .....               | 268 |
| Figure 6-36 Zoning for Rear-Mounted Twin Propellers (Low- or High-Wing) .....                | 269 |
| Figure 6-37 Zoning for Front- and Rear-Mounted Propellers (Low- or High-Wing).....           | 270 |
| Figure 6-38 Zoning for High-Wing with Front and Rear Propellers Mounted Above Fuselage ..... | 271 |
| Figure 6-39 Zoning for Low or High Wing Canard with Twin Rear-Facing Props.....              | 272 |
| Figure 6-40 Zoning for Single-Propeller Biplane.....                                         | 273 |
| Figure 6-41 Zoning for Empennage .....                                                       | 274 |



|                                                                                  |     |
|----------------------------------------------------------------------------------|-----|
| Figure 6-42 V-tail Empennage Zoning .....                                        | 275 |
| Figure 6-43 Dual Vertical Stabilizer With Low Horizontal Stabilizer Zoning ..... | 275 |
| Figure 6-44 Example Lightning Zoning for Single-Engine Aircraft .....            | 276 |
| Figure 6-45 Example Lightning Zoning for Twin-Engine Aircraft .....              | 277 |

## TABLES

| <u>TABLE</u>                                                                        | <u>PAGE</u> |
|-------------------------------------------------------------------------------------|-------------|
| Table 1-1: Reference Documents .....                                                | 12          |
| Table 1-2 G5 Attitude and G5 DG/HSI Equipment .....                                 | 13          |
| Table 1-3: Physical Characteristics .....                                           | 22          |
| Table 1-4: Power Requirements .....                                                 | 22          |
| Table 3-1: Contents of the G5 Installation Kit with LPM (011-03892-01) .....        | 24          |
| Table 3-2: Contents of the GMU 11 Installation Kit (011-04349-90) .....             | 24          |
| Table 3-3: Contents of the GMU 11 and GAD 13 Connector Kits (011-03002-00/10) ..... | 25          |
| Table 3-4: Contents of the G5 Connector Kit with LPM (011-03002-20) .....           | 25          |
| Table 3-5: Contents of the GAD 29/29B Connector Kit (011-03271-00) .....            | 25          |
| Table 3-6: G5 Adapter Plate .....                                                   | 26          |
| Table 3-7: G5 Recessed Adapter Plate .....                                          | 26          |
| Table 3-8: G5 and Supporting LRU Circuit Breaker Labels .....                       | 29          |
| Table 4-1 GMU 11 Supporting Hardware .....                                          | 58          |
| Table 4-2 GAD 29/29B, GAD 13 Supporting Hardware .....                              | 61          |
| Table 4-3: Contact Crimp Tooling .....                                              | 72          |
| Table 4-4: G5 (1P51, 2P51), GMU 11 (P111), and GAD 13 (P131) Connector Parts .....  | 74          |
| Table 4-5: GAD 29/29B 9-pin (P291) Connector Parts .....                            | 75          |
| Table 4-6: GAD 29/29B 25-pin (P292) Connector Parts .....                           | 76          |
| Table 4-7: LRU Weights .....                                                        | 81          |
| Table 4-8: Sample Net Electrical Load Change Calculation .....                      | 82          |
| Table 4-9: Bonding Strap Potential Part Numbers .....                               | 94          |
| Table 5-1: Non-Garmin Autopilots .....                                              | 173         |
| Table 6-1: Post-Installation Calibration Procedure Summary .....                    | 189         |
| Table 6-2: Heading Verification .....                                               | 196         |
| Table 6-3: Aircraft Model-Specific Data .....                                       | 236         |
| Table 6-4: Lightning Zoning Legend .....                                            | 258         |

## APPENDICES

| <u>APPENDIX</u>                                           | <u>PAGE</u> |
|-----------------------------------------------------------|-------------|
| APPENDIX A - CONNECTOR INFORMATION .....                  | 210         |
| APPENDIX B - OUTLINE AND INSTALLATION DRAWINGS .....      | 217         |
| APPENDIX C - MAGNETIC INTERFERENCE SURVEY .....           | 228         |
| APPENDIX D - GMU 11 MOUNTING IN NONMETALLIC WINGTIP ..... | 232         |
| APPENDIX E - MODEL SPECIFIC DATA .....                    | 235         |
| APPENDIX F - LIGHTNING PROTECTION .....                   | 258         |



## 1 GENERAL DESCRIPTION

### 1.1 Introduction

The G5 is an electronic instrument display capable of operating as a primary attitude indicator, backup attitude indicator with primary rate-of-turn indicator, DG or HSI. This STC approves the installation of the G5(s) in the existing instrument panel.

In the attitude application, the Garmin G5 indicator can serve as an attitude indicator or rate-of-turn indicator. The G5 can also serve as a DG or HSI, either standalone or in combination with a G5 attitude display.

When installed as a DG/HSI with a GAD 29/29B/29D, the G5 can interface with a Garmin GFC 500, Garmin GFC 600 and Non-Garmin autopilots using the GAD 29B or GAD 29D.

The G5 is designed to be installed into a standard 3 1/8" instrument hole in place of the existing indicators mentioned previously. The other primary flight instruments remain in the current approved locations. The G5 cannot replace an existing primary attitude indicator that has a Flight Director; however, if the existing attitude indicator is interfaced to the autopilot and it does not include a Flight Director, that existing attitude indicator can be moved to the rate-of-turn indicator location and the G5 installed as the primary attitude indicator.

Alternatively, for installations that do not install the G5 as a replacement primary attitude indicator, the G5 can be installed as a second attitude indicator in place of the existing rate-of-turn indicator. If the existing rate-of-turn indicator is interfaced with the autopilot, it cannot be replaced by a G5. The G5 can only be installed in the locations specified in this STC. It is the installer's responsibility to ensure the installation limitations are considered prior to modifying the aircraft.



#### NOTE

*Throughout this document the term "rate-of-turn indicator" will be used and could be speaking to either a turn coordinator or turn and bank indicator. Typically these instruments are used to cross-check the attitude indicator and directional gyro for bank information. However, these instruments only provide information that the aircraft is in a turn and whether the turn is at the standard rate (a standard rate turn is 3 degrees per second, or 2 minutes for a full 360-degree circle). They do not provide information on the bank angle. Regardless of the specific instrument installed the G5 is capable of replacing either configuration of a turn coordinator or turn and bank indicator.*

The software versions and information in this document are subject to change without notice. Visit [www.Garmin.com](http://www.Garmin.com) and navigate to the Aviation Product/General Aviation/Indicators/G5 page for current updates and supplemental information concerning operation of the G5 attitude indicator.



## 1.2 Acronyms and Abbreviations

The following acronyms and abbreviations are used in this manual:

|             |                                   |             |                                          |
|-------------|-----------------------------------|-------------|------------------------------------------|
| <b>AFMS</b> | Airplane Flight Manual Supplement | <b>HSI</b>  | Horizontal Situation Indicator           |
| <b>ALT</b>  | Altitude (mode)                   | <b>ICA</b>  | Instructions for Continued Airworthiness |
| <b>AML</b>  | Approved Model List               | <b>I/O</b>  | Input/Output                             |
| <b>CAN</b>  | Controller Area Network           | <b>LPM</b>  | Lightning Protection Module              |
| <b>DG</b>   | Directional Gyro                  | <b>LRU</b>  | Line Replaceable Unit                    |
| <b>CFR</b>  | Code of Federal Regulations       | <b>OAT</b>  | Outside Air Temperature                  |
| <b>FAA</b>  | Federal Aviation Administration   | <b>STC</b>  | Supplemental Type Certificate            |
| <b>FIKI</b> | Flight Into Known Icing           | <b>TSO</b>  | Technical Standard Order                 |
| <b>GPS</b>  | Global Positioning System         | <b>WAAS</b> | Wide Area Augmentation System            |

## 1.3 Reference Documents

**Table 1-1: Reference Documents**

| Title                                                                                                                        | Document Number |
|------------------------------------------------------------------------------------------------------------------------------|-----------------|
| FAA Advisory Circular, Acceptable Methods, Techniques, and Practices – Aircraft Inspection and Repair                        | AC 43.13-1B     |
| FAA Advisory Circular, Acceptable Methods, Techniques, and Practices – Aircraft Alterations                                  | AC 43.13-2B     |
| Aerospace Systems Electrical Bonding and Grounding for Electromagnetic Compatibility and Safety                              | SAE ARP1870     |
| Standard Guide for Aircraft Electrical Load and Power Source Capacity Analysis                                               | ASTM F 2490-05  |
| GTN 6XX/7XX Install Manual                                                                                                   | 190-01007-A3    |
| GNS 400W Series Installation Manual                                                                                          | 190-00356-08    |
| GNS 500W Series Installation Manual                                                                                          | 190-00357-08    |
| Garmin G5 Electronic Flight Instrument Part 23 AML STC Maintenance Manual including Instructions for Continued Airworthiness | 190-01112-11    |
| Pilots Guide, Garmin G5 Electronic Flight Instrument, Part 23 AML STC                                                        | 190-01112-12    |
| Airplane Flight Manual Supplement Garmin G5 Electronic Flight Instrument Part 23 AML STC                                     | 190-01112-13    |
| GFC 600 Automatic Flight Control System Part 23 AML STC Installation Manual                                                  | 190-01937-00    |
| GFC 500 Autopilot with Electronic Stability and Protection Part 23 AML STC Installation Manual                               | 190-02291-00    |
| GPS 175 Part 23 AML STC Installation Manual                                                                                  | 190-02207-A1    |
| GNX 375 Part 23 AML STC Installation Manual                                                                                  | 190-02207-A4    |
| GNS 400 Series Installation Manual                                                                                           | 190-00140-02    |
| GNS 500 Series Installation Manual                                                                                           | 190-00181-02    |
| GTN Xi Part 23 AML STC Installation Manual                                                                                   | 190-01007-C0    |
| Installation Manual G3X Touch EFIS Part 23 AML STC                                                                           | 190-02472-01    |



## 1.4 STC Permission

A permission letter to use this STC data is available for download for each authorized G5 installation. The STC Installation Kit contains instructions for downloading the STC permission letter from [www.Garmin.com](http://www.Garmin.com). Contact a local Garmin Dealer for G5 Attitude, G5 DG and G5 HSI STC Kit Part Numbers.

## 1.5 Scope

This manual applies to the modification of an aircraft listed on the Part 23 AML STC SA01818WI for the installation of equipment listed below. Only the interfaces between the Garmin G5 Electronic Flight Instrument and equipment listed in this manual are approved by the STC.

**Table 1-2 G5 Attitude and G5 DG/HSI Equipment**

| Model              | Nomenclature                         | Unit P/N     | Mod Status | Catalog P/N  | Software P/N and Version |
|--------------------|--------------------------------------|--------------|------------|--------------|--------------------------|
| G5                 | Electronic Flight Instrument         | 011-03809-00 | --, 1      | 010-01485-00 | 006-B2304-XX*            |
| G5                 | Installation Kit                     | 011-03892-01 | --         | 010-12493-11 | N/A                      |
| G5                 | Battery pack                         | 011-03893-00 | --         | 010-12493-00 | N/A                      |
| G5                 | Battery pack                         | 011-03893-01 | --         | 010-12493-01 | N/A                      |
| G5                 | Battery pack                         | 011-03893-02 | --         | 010-12493-02 | N/A                      |
| GMU 11             | Magnetometer                         | 011-04349-01 | --         | 010-01788-01 | 006-B2770-XX*            |
| GMU 11             | GMU 11 Installation Kit              | 011-04349-90 | --         | --           | N/A                      |
| GAD 29             | Data Bus Converter                   | 011-03236-01 | --         | 010-01172-01 | 006-B1760-XX*            |
| GAD 29B**          | Data Bus Converter                   | 011-03236-11 | --         | 010-01172-11 | 006-B1760-XX*            |
| GAD 29D            | Data Bus Converter                   | 011-03236-21 | --         | 010-01172-21 | 006-B4077-XX*            |
| GAD 29/29B/29D     | GAD 29/29B/29D Connector Kit         | 011-03271-00 | --         | N/A          | N/A                      |
| GPS Antenna, BNC   | Glareshield mount GPS antenna        | 011-04036-10 | --         | 010-12444-10 | N/A                      |
| GPS Antenna, TNC   | Glareshield mount GPS antenna        | 011-04036-00 | --         | 010-12444-00 | N/A                      |
| TNC/BNC Adapter*** | Coax adapter for glareshield antenna | 330-01754-00 | --         | --           | N/A                      |
| GAD 13             | Unit Only                            | 011-04938-00 | --         | 010-02203-00 | N/A                      |
| GAD 13             | Connector Kit                        | 011-03002-10 | --         | N/A          | N/A                      |
| GTP 59             | OAT Probe Installation Kit           | 494-00022-08 | --         | 011-00978-00 | N/A                      |



| Model                                                                                                                                                                                                                                                                                                                                                                                                                                                                                                                                                                                                                                                                                                                                                                                                          | Nomenclature | Unit P/N | Mod Status | Catalog P/N | Software P/N and Version |
|----------------------------------------------------------------------------------------------------------------------------------------------------------------------------------------------------------------------------------------------------------------------------------------------------------------------------------------------------------------------------------------------------------------------------------------------------------------------------------------------------------------------------------------------------------------------------------------------------------------------------------------------------------------------------------------------------------------------------------------------------------------------------------------------------------------|--------------|----------|------------|-------------|--------------------------|
| <p>* The approved G5 Part 23 AML STC Electronic Flight Instrument software is P/N 006-B2304-XX. XX denotes the specific version P/N, i.e. 006-B2304-02 is software version 2.60. The G5 Electronic Flight Instrument, GMU 11 Magnetometer and GAD 29/29B/29D listed above is shipped with approved software. To verify the latest approved software visit <a href="http://www.Garmin.com">www.Garmin.com</a> and navigate to the Aviation /General Aviation/Flight Instruments &amp; Indicators/G5 page. Select 'Software' in the overview tab.</p> <p>** The GAD 29B/GAD 29D is only required in installations that utilize the G5 heading and course output to an autopilot, or interface with a Garmin navigator.</p> <p>*** TNC/BNC adapter only required for installations using the TNC GPS Antenna.</p> |              |          |            |             |                          |

## 1.6 System Overview

### 1.6.1 G5 Attitude Indicator

The G5 Electronic Flight Instrument configured as an attitude indicator, is shown in Figure 1-1. The G5 is an electronic instrument display operating as a standalone flight display. It features a bright, sunlight readable, 3.5-inch color display which is sized to fit in a standard 3-1/8-inch instrument cutout. The G5 contains integrated attitude/air data sensors that provide display of attitude and secondary display of air data information. The G5 has battery backup and in the case of aircraft power loss will sustain G5 operation with up to 4 hours of emergency power.



Figure 1-1 G5 Electronic Flight Instrument (Attitude)

#### 1.6.1.1 Attitude

The G5 calculates aircraft attitude using information from its built-in inertial sensors. If the G5 senses that the attitude solution is valid, but not yet within the internal accuracy limits, "ALIGNING" is displayed.

The G5 can align itself both while taxiing and during level flight.

The G5 attitude functions are shown below:

- Pitch
- Roll



### 1.6.1.2 Turn Rate

The Turn Rate Indicator is located at the bottom of the display. A magenta Turn Rate Trend Vector shows the current turn rate. A standard-rate turn (3 deg/sec) is shown on the indicator by the trend vector stopping at the standard turn rate tick mark.

### 1.6.1.3 Slip/skid

The Attitude Indicator displays slip/skid information as indicated by the location of the ball at the lower center portion of the indicator.

### 1.6.1.4 GPS Aiding

The G5 requires GPS for attitude aiding. It contains an internal GPS receiver that can be connected to a GPS antenna or optionally can use external GPS input if available.

As installed in this STC, the G5 receives the GPS position for aiding via the following methods:

- GTN 6XX/7XX series navigators (See section 1.6.1.11)
- GNS 4XX/5XX with WAAS series navigators (See section 1.6.1.11)
- GNS 480 series navigator (See section 1.6.1.11)
- GTX 3x5 w/GPS transponder with software version 2.10 or later. (See section 1.6.1.11)
- Connection to the Glare Shield Mounted GPS Antenna (See section 1.6.5)
- GPS 175/GNX 375 series navigators (See section 1.6.1.11)

Note: It is possible to connect to both a Glare Shield Mounted GPS Antenna via a coaxial cable and a GPS navigator over RS-232 simultaneously.

Additionally, the G5 functions provided by the GPS are shown below:

- Ground Track
- Ground Speed (GS)

### 1.6.1.5 Air Data

The G5 unit is connected to the aircraft Pitot / Static system and optionally connected to the GAD 13 for Outside Air Temperature (OAT) information. See section 4.1.2.4 for details.

The G5 functions provided by the air data are shown below:

- Secondary Airspeed indicator
- Secondary Barometric altimeter
- Secondary Vertical speed
- Secondary Altimeter Barometric Setting
- Secondary Altimeter
- Secondary Altitude Display
- Selected altitude setting, bug and visual altitude alerting
- Secondary Vertical Speed Indicator
- Vspeed references
- True Airspeed (TAS)
- Crosswind speed and direction
- OAT

The G5 is capable of sharing OAT information with navigators and transponders over the CAN bus, which is converted to ARINC 429 at the GAD 29/29B/29D.

## 1.6.1.6 Standby Battery

The standby battery is required. The G5 has an externally mounted lithium – ion battery that sustains the G5 flight display with up to 4 hours of emergency power.



Figure 1-2 G5 Standby Battery

## 1.6.1.7 G5 Attitude Interfaced to GMU 11

The GMU 11 magnetometer can be installed as an optional interface for a standalone G5 attitude display. This will allow the display of heading on the attitude display in place of track, but would not allow the removal of the existing DG.

## 1.6.1.8 G5 Attitude Interface Summary

The G5 Electronic Flight Instrument when configured as an attitude indicator in this STC installation uses 14VDC or 28 VDC power, ground, RS-232, CAN bus, and coax connection for the Glare Shield Mounted GPS Antenna. The following list is a summary of interfaces used by the G5 Attitude indicator.

- Aircraft Power and Ground
- Aircraft Pitot/Static
- GPS Coax connection
- One RS-232 connection
- One CAN bus connection
- Standby battery

## 1.6.1.9 G5 Attitude Power and Ground Interface Summary

The G5 uses 14VDC or 28 VDC power and aircraft ground. Reference Section 5 for wiring details.

## 1.6.1.10 G5 Attitude Pitot/Static Interface Summary

The G5 requires pitot and static inputs for the altitude and airspeed functions. Reference Section 4.1.5 for installation specifics.





### 1.6.1.11 G5 Attitude RS-232 Interface Summary

The G5 Attitude indicator can utilize RS-232 connections when available to receive GPS data.

When a G5 HSI is installed, the G5 Attitude indicator can utilize the RS-232 connection for GPS and VHF navigation information.

If an existing connection is made to the RS-232 port, the G5 connection can be spliced into the existing wiring at the connector. For specific wiring information, refer to Section 5.

For specific configuration settings for RS-232 refer to Section 5.

### 1.6.1.12 G5 Attitude CAN Bus Interface Summary

The G5 Attitude indicator can utilize CAN bus connections when specified by a specific equipment configuration to allow heading information from the GMU 11, communication of navigation data from the GAD 29/29B/29D, communication between the G5 Attitude indicator and the G5 HSI, and communication of Outside Air Temperature (OAT) information from the GAD 13.

For specific wiring information, refer to Section 5.

## 1.6.2 G5 DG/HSI Indicator

The G5 Electronic Flight Instrument configured as an HSI, is shown in Figure 1-3. The G5 is an electronic instrument display operating as a standalone flight display. It features a bright, sunlight readable, 3.5-inch color display which is sized to fit in a standard 3-1/8-inch instrument cutout. The G5 contains integrated attitude/air data sensors that provide a backup display of attitude and air data information. The G5 has battery backup and in the case of aircraft power loss will sustain G5 operation with up to 4 hours of emergency power. When the G5 is installed as a DG/HSI the battery backup is optional.



Figure 1-3 G5 Electronic Flight Instrument (DG/HSI)

The Garmin G5 indicator can replace an existing vacuum-driven or electro mechanical DG/HSI. In this location the G5's primary function is the display of slaved compass, VHF NAV and/or GPS NAV, system



#1 or #2. The possible configurations for a G5 DG/HSI are discussed below. (Note: The VHF navigators and GPS navigators interfaced by this STC are not installed by this AML STC. Only the interface of the VHF NAV, GPS NAV and G5 Attitude and G5 DG/HSI are approved with this STC.)

### 1.6.2.1 G5 Slaved DG

The basic installation is a G5 in the DG indicator location and a GMU 11.

- In this configuration the G5 is installed as a slaved compass with no NAV information.
- The G5 DG can be used as a backup Attitude/Airspeed/Altitude Indicator.

### 1.6.2.2 G5 HSI VHF NAV

For installations where the G5 HSI is being used for basic VHF NAV, the G5 HSI is installed with a GNC255 or SL30.

- The G5 HSI will be a situationally correct display of VHF NAV course information with the heading of the aircraft
- The G5 HSI will be used to input OBS/Course information
- The G5 HSI can be used as a backup Attitude/Airspeed/Altitude Indicator
- If installed, a G5 Attitude indicator can also present VHF NAV lateral and vertical deviation

### 1.6.2.3 G5 HSI GPS NAV

For installations where the G5 HSI is being used for GPS NAV, the G5 will be installed with a Garmin GPS navigator and the GAD 29/29B/29D

- The G5 HSI will be a situationally correct display of GPS NAV information with the heading of the aircraft
- The G5 HSI will be used to input OBS/Course information
- The G5 HSI can be used as a backup Attitude/Airspeed/Altitude Indicator
- If installed, a G5 Attitude indicator can also present GPS NAV lateral and vertical deviation

### 1.6.2.4 G5 HSI VHF NAV and GPS NAV

For installations where the G5 HSI is being used for full VHF NAV and GPS NAV, the G5 will be installed with a Garmin GPS/VHF navigator and the GAD 29/29B/29D.

- The G5 HSI will be a situationally correct display of VHF NAV or GPS NAV information with the heading of the aircraft
- The G5 HSI will be used to input OBS/Course information
- The G5 HSI can be used as a backup Attitude/Airspeed/Altitude Indicator
- If installed, a G5 Attitude indicator can also present VHF NAV or GPS NAV lateral and vertical deviation

### 1.6.2.5 Backup Attitude Indicator

All of the functions listed in 1.6.1 are also available by selecting the G5 HSI Menu via the knob and selecting PFD.



### 1.6.2.6 G5 DG/HSI Interface Summary

- Aircraft Power and Ground
- Aircraft Pitot/Static
- GPS Coax connection
- One RS-232 connection
- One CAN bus connection
- Standby battery (optional)

### 1.6.2.7 G5 DG/HSI Power and Ground Interface Summary

The G5 uses 14VDC or 28VDC power and aircraft ground. Reference Section 5 for wiring details.

### 1.6.2.8 G5 DG/HSI Pitot/Static Interface Summary

The G5 requires pitot and static inputs, reference Section 4.1.5 for more information on pneumatic connections.

### 1.6.2.9 G5 DG/HSI RS-232 Interface Summary

The G5 DG/HSI can utilize RS-232 connections when available to receive

- GPS data for aiding.
- VHF navigation information, both lateral and vertical.

For specific configuration settings for RS-232 refer to Section 5.

If an existing connection is made to the RS-232 port, the G5 connection can be spliced into the existing wiring at the connector. For specific wiring information, refer to Section 5.

### 1.6.2.10 G5 DG/HSI CAN Bus Interface Summary

The G5 DG/HSI can utilize CAN bus connections when specified by a specific equipment configuration to allow heading information from the GMU 11, communication of navigation data from the GAD 29/29B/29D, communication between the G5 Attitude instrument and the G5 HSI, and communication of OAT information from the GAD 13.

For specific wiring information, refer to Section 5.

### 1.6.2.11 Standby Battery

The standby battery is optional for the DG/HSI installation. The G5 has an externally mounted lithium – ion battery that sustains the G5 flight display with up to 4 hours of emergency power.

## 1.6.3 GMU 11 Magnetometer

The Garmin GMU 11 Magnetometer is a remote mounted device that interfaces with a Garmin G5 to provide heading data to the G5 Attitude and/or G5 DG/HSI. The Garmin G5 and GMU 11 magnetometer replaces traditional rotating mass instruments. The GMU 11 Magnetometer uses magnetic field measurements to create electronically stabilized heading data. The GMU 11 is required when a G5 is installed as a DG/HSI.



Figure 1-4 GMU 11

## 1.6.4 GAD 29/29B/29D

The GAD 29/29B/29D is a light-weight, remote-mount unit that allows interface to IFR navigators such as the GNS and GTN series. The GAD 29/29B/29D has a 25 pin D-sub connector and a 9 pin D-sub connector. These connectors provide the following functionality:

- 2 Low Speed ARINC 429 Transmitters
- 4 Low Speed ARINC 429 Receivers
- 1 CAN Network Port
- \*Analog Outputs
- \*Excitation Pass Through

\*GAD29B/29D only

For the G5 Attitude and/or G5 DG/HSI installation the GAD 29/29B/29D will receive ARINC 429 data from the navigators interfaced and transmit that information onto the CAN bus to be consumed by the G5. The GAD 29/29B/29D can run on 14VDC or 28VDC. The GAD 29/29B/29D can also receive OAT information over the CAN bus to be converted to ARINC 429 data and transmitted to the navigators.

The GAD 29B/29D contains the same characteristics and function of the GAD 29 as well as providing autopilot heading and course datum to allow a G5 DG/HSI to be interfaced with autopilots. Reference section 5.22 and 5.24 for approved autopilot interfaces.

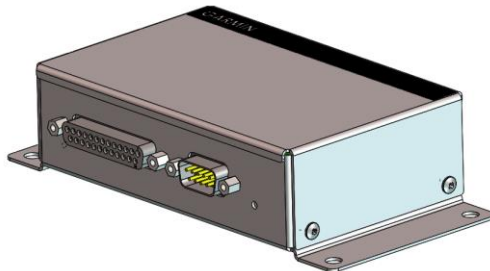


Figure 1-5 GAD 29/29B/29D

## 1.6.5 Glare Shield Mounted GPS Antenna

The glareshield-mounted GPS antenna (Garmin part number 011-04036-00) feeds a GPS receiver inside the G5 which provides position, velocity, and time data to support various functions. This antenna requires Garmin part number 330-01754-00 to connect to the G5.

If the primary G5 is installed as an ADI, HSI, or DG and not connected to a WAAS enabled GPS source, the G5 must be connected to this antenna.

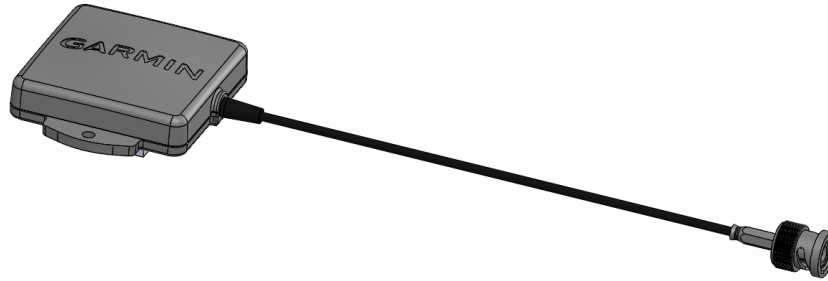


Figure 1-6 Glare Shield Mounted GPS Antenna

### 1.6.6 GAD 13

The GAD 13 is a small unit used to interface to OAT probes. The GAD 13 provides a standard three-wire or two-wire interface that can be connected to the following approved OAT probes:

- GTP 59
- C307PS (Davtron)

OAT analog information from the GAD 13 is converted to digital information, and passed to other G5 system LRUs using CAN communication. Connection to GAD 13 enables the G5 to display TAS, OAT, and crosswind information.

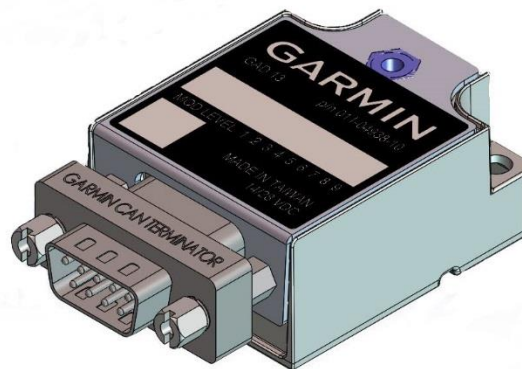


Figure 1-7 GAD 13

### 1.6.7 GTP 59

The Garmin GTP 59 is an externally mounted temperature probe that provides raw outside air temperature data. The device is a three-wire temperature probe interface with a pre-installed wire lead that is 10 feet long.



Figure 1-8 GTP 59 (Temperature Probe)





## 2 LIMITATIONS

### 2.1 Installation Limitations

It is the installer's responsibility to ensure the installation will meet the requirements in this manual prior to modification of the aircraft.

The installation of the G5 requires the retention of the mechanical airspeed indicator, altimeter, and vertical speed indicator.

- For this STC, a maximum of two G5 units may be installed in an aircraft.
- For installations in aircraft approved for IFR operations:
  - If the G5 is installed as the primary attitude indicator, the existing rate of turn indicator must be retained.
  - If the G5 is installed as the rate of turn indicator, the existing primary attitude indicator must be retained.
- For installations in aircraft approved for VFR-only operations;
  - The G5 can be installed as the attitude indicator and rate of turn indicator without retention of either the existing attitude indicator or rate of turn indicator.

As installed by this STC, the G5:

- is NOT approved in FAA certified aircraft that:
  - have a gross take-off weight more than 6000 lbs
  - have more than 6 seats including pilot/copilot
  - are equipped with integrated avionics systems such as, G950, G1000, Avidyne Entegra, Sagem, etc.
- must be installed in an aircraft with an electrical power generating system capable of supplying 14 VDC or 28 VDC
- if a G5 is being installed as an attitude indicator and an existing attitude indicator is retained, the G5 pointer type must be configured to match the existing indicator pointer type
  - Fixed Pointer Type / G5 Config = Ground
  - Movable Pointer Type / G5 Config = Sky
- cannot replace a primary attitude indicator that includes a flight director or is part of an autopilot system (an existing attitude indicator in the primary location that is part of an autopilot but without flight director may be moved to the turn coordinator location and a G5 installed in the primary location)
- cannot replace the turn coordinator that is part of an autopilot system
- cannot replace a DG/HSI that is part of an autopilot system that is not an approved autopilot, see Table 5-1.
- cannot replace the non-stabilized magnetic compass (Whiskey Compass must be retained in the aircraft)
- must be installed in an instrument panel constructed of aluminum with a minimum thickness of .040 inches.
- is only approved to interface with aircraft systems specified in this manual
- must not have interface cables and wiring installed in fuel bays
- cannot interface with dual navigators if G5 is interfaced with a non-Garmin autopilot

### 2.2 Operational Limitations

Refer to the Airplane Flight Manual Supplement (AFMS) for operational limitations.



### 3 INSTALLATION OVERVIEW

#### 3.1 Introduction

The following section contains an overview of the steps required for the installation of the G5 Electronic Flight Instrument. This section includes requirements for selection of proper locations in the aircraft, as well as requirements for supporting structure, mechanical alignment and wiring. Any restrictions on nearby equipment and requirements are also specified.

#### 3.2 Installation Materials

There are two installation kits presented in Table 3-1 and Table 3-2, only one is required for each G5 installation.

**Table 3-1: Contents of the G5 Installation Kit with LPM (011-03892-01)**

| Item                                     | Garmin P/N   | Quantity |
|------------------------------------------|--------------|----------|
| Connector Kit, 9 Pin, w/CAN Term, w/LPM* | 011-03002-20 | 1        |
| Mounting Rack, G5                        | 115-02251-03 | 1        |
| Screw, 6-32, 0.500"                      | 211-60207-12 | 3        |

\*NOTE: Not all items included in kit P/N 011-03002-20 are used in this installation.

The installation kit listed in Table 3-2 is required any time a GMU 11 is installed.

**Table 3-2: Contents of the GMU 11 Installation Kit (011-04349-90)**

| Item                              | Garmin P/N   | Quantity |
|-----------------------------------|--------------|----------|
| Connector Kit, 9 Pin, w/CAN Term* | 011-03002-00 | 1        |
| Nylon Locking 6-32 Nut            | 210-10008-08 | 4        |
| Screw, 6-32, 0.500"               | 211-60207-12 | 4        |
| Flat 6-32 Washer                  | 212-00024-06 | 4        |

\*NOTE: Not all items included in kit P/N 011-03002-00 are used in this installation.





The connector kit P/N 011-03002-10 is required to be ordered separately for a GAD 13 installation. For the G5 and GMU 11, the connector kit P/N 011-03002-00/20 is part of the LRU's associated installation kit.

**Table 3-3: Contents of the GMU 11 and GAD 13 Connector Kits (011-03002-00/10)**

| Item                                            | Garmin P/N   | Quantity |
|-------------------------------------------------|--------------|----------|
| Sub-Assy, Bkshl w/Hdw, Jackscrew, 9 pin         | 011-01855-00 | 1        |
| Sub Assy, CAN Termination Kit*                  | 011-02887-00 | 1        |
| Conn, Rcpt, D-Sub, Crimp Socket, 9 Ckt          | 330-00625-09 | 1        |
| Contact, Sckt, D-Sub, Crimp, Size 20, 20-24 AWG | 330-00022-02 | 9        |

\*NOTE: Not all items included in kit P/N 011-02887-00 are used in this installation

**Table 3-4: Contents of the G5 Connector Kit with LPM (011-03002-20)**

| Item                                              | Garmin P/N   | Quantity |
|---------------------------------------------------|--------------|----------|
| Sub-Assy, Bkshl w/Hdw, Jackscrew, 9 pin, w/ LPM** | 011-01855-20 | 1        |
| Sub Assy, CAN Termination Kit*                    | 011-02887-00 | 1        |
| Conn, Rcpt, D-Sub, Crimp Socket, 9 Ckt            | 330-00625-09 | 1        |
| Contact, Sckt, D-Sub, Crimp, Size 20, 20-24 AWG   | 330-00022-02 | 9        |

\*Not all items included in kit P/N 011-02887-00 are used in this installation

\*\*See Figure 4-50 for connector assembly. See section 5.22 for LPM Wiring Interface.

The installation kit listed in Table 3-5 is required whenever a GAD 29/29B/29D is installed.

**Table 3-5: Contents of the GAD 29/29B/29D Connector Kit (011-03271-00)**

| Item                                     | Garmin P/N   | Quantity |
|------------------------------------------|--------------|----------|
| Backshell w/Hdw, Jackscrew, 9 Pin        | 011-01855-00 | 1        |
| Backshell w/Hdw, Jackscrew, 25 Pin       | 011-01855-02 | 1        |
| Conn, Plug, D-Sub, Crimp Pin, 25 Place   | 330-00624-25 | 1        |
| Conn, Rcpt, D-Sub, Crimp Sckt, 9 Place   | 330-00625-09 | 1        |
| Contact, Socket, Military Crimp, Size 20 | 336-00022-02 | 11       |
| Contact, Pin, Military Crimp, Size 20    | 336-00024-00 | 27       |



The item listed in Table 3-6 will be supplied when a G5 DG/HSI is ordered. The adapter plate is used whenever a G5 is installed and any instrument panel modification has taken place or a G5 is installed in an instrument hole with cutouts for instrument knobs. Alternatively the installer can field fabricate the adapter as needed. Reference 4.1.2.4 for installation details.

**Table 3-6: G5 Adapter Plate**

| Item             | Garmin P/N   | Quantity    |
|------------------|--------------|-------------|
| G5 Adapter Plate | 115-02642-00 | As required |

The item listed in Table 3-7 is optional. It can be ordered from Garmin or fabricated in accordance with Section 4.1.2.6. The recessed adapter plate is only used when recessing the G5 into the instrument panel. This same part can be used when installing single or dual recessed G5 units. Reference 4.1.2.6 for installation details.

**Table 3-7: G5 Recessed Adapter Plate**

| Item                      | Garmin P/N   | Quantity    |
|---------------------------|--------------|-------------|
| G5 Recessed Adapter Plate | 115-02733-00 | As required |

### 3.2.1 Materials Required but Not Supplied

The following installation materials are required, but are not available from Garmin:

- Insulated stranded wire (MIL-W-22759/34 or MIL-W-22759/16)
- Shielded wire (MIL-C-27500 cable utilizing M22759/34 wire (SD) and ETFE jacket or MIL-C-27500 cable utilizing M22759/16 wire (TE) and ETFE jacket )
- Push/pull manually resettable circuit breakers.

Aircraft with 14 VDC or 28 VDC electrical systems require one of the following circuit breakers:

- MS26574-5 (5 Amp, G5, GMU 11, GAD 29/29B/29D, GAD 13)

Or

- Garmin P/N 355-00010-08 (5 Amp, G5, GMU 11, GAD 29/29B/29D, GAD 13)

- Cable ties or lacing cord
- MS25036 ring terminals (for grounding and circuit breaker connections)
- Shield terminators (AS83519/1-X or AS83519/2-X or equivalent)
- Silicone fusion tape, A-A-59163 (MIL-I-46852C or equivalent)
- Environmental splice (AS81824/1-X, where X=size or equivalent)
- Flat braid, 1/16" (AA59569F36T0062 or equivalent)
- Tubing and fittings are required to connect pitot and static air to the G5. Pitot and Static plumbing parts are aircraft specific, see Section 4.1.5.
- 120Ω CAN cable, see section 3.4.5 for more information. There are several options for this wire.
  - GigaFlight Connectivity P/N GF120-24CANB-1
- Or
  - GigaFlight Connectivity P/N GF120T-24CANB



- GigaFlight contact information:  
GigaFlight Connectivity Inc.  
6180 Industrial Ct.  
Greendale, WI 53129  
United States  
Toll Free: +1 (844) 303-1093  
Phone: +1 (414) 488-6320  
Email: [info@gigaflightinc.com](mailto:info@gigaflightinc.com)
- Carlisle IT P/N CAN24TST120(CIT),
  - Carlisle IT contact information:  
Carlisle Interconnect Technologies  
5300 W. Franklin Drive  
Franklin, WI 53132  
United States  
Toll Free: +1 (800) 327-9473  
Phone: +1 (414) 421-5300

The following installation materials may be required depending on the installation, but are not available from Garmin:

- 2024-T3 aluminum alloy sheet per AMS-QQ-A-250/4 or clad 2024-T3 aluminum alloy sheet per AMS-QQ-A-250/5. Minimum sheet thickness requirements:
  - 0.032" for GMU 11 magnetometer and GAD 13 supporting structure.
  - 0.040" for GAD 29/29B/29D, Glare Shield Mounted GPS Antenna supporting structures.
- Aircraft grade fasteners e.g., AN525 screws, MS20426AD rivets, MS21059 rivet nut plates, MS21071 reduced rivet spacing nut plates. NAS1832, NAS1834, or NAS1836 potted inserts maybe required if honeycomb core panels are used to support the installation of G5 components.
- Synthetic Fastener Tape, A-A-55126, used for mounting Glare Shield Mounted GPS Antenna



### 3.3 Test Equipment

The following test equipment is required to complete the G5 installation and to perform post-installation checkout of the system:

- Ground power cart (capable of supplying power to the aircraft systems and avionics)
- Air data test set (e.g. Barfield DPS450 or similar)
- VHF NAV test set
- Low resistance ohmmeter
- Digital Level (or equivalent)

The following equipment may be required based on the units being installed and the particular aircraft, see Section 4.1 for information:

- Laser Square
- Protractor Tool
- Plumb Bob
- Aircraft Jack Set

### 3.4 Installation Considerations

The installation instructions are intended to be used in coordination with the avionics installation practices in AC 43.13-1B and AC 43.13-2B.

- Modification of existing plastic instrument panel overlays may be required to install the G5 electronic flight instrument.
- Fabrication of a wiring harness is required.
- Sound mechanical and electrical methods and practices are required to achieve optimum system performance.

#### 3.4.1 GPS Antenna

A GPS signal is required. The G5 can use the Glare Shield Mounted GPS Antenna or GPS data from one of the GPS navigators or a GPS-enabled GTX 3x5 transponder listed in Section 1.6.1.4. The G5 unit is capable of utilizing both a GPS Navigator/GTX 3x5 and a Glare Shield Mounted GPS Antenna for GPS position simultaneously.

In a dual G5 installation only, the G5 Attitude requires the GPS antenna connection. The GPS information is communicated to the G5 DG/HSI over the CAN bus.

If a GPS Navigator or a GTX 3x5 is used for a GPS signal without a Glare Shield Mounted GPS Antenna, disable the internal GPS receiver of the G5. If the G5 is connected to the Glare Shield Mounted GPS Antenna, enable the internal GPS receiver. See Section 5 for configuration settings.

This STC approves the installation and interface of the BNC Glare Shield Mounted GPS Antenna, P/N 011-04036-10. The 011-04036-00 TNC Glare Shield Mounted GPS Antenna is approved as well, but requires a TNC/BNC adapter to connect this antenna to the G5, adapter P/N 330-01754-00.

#### 3.4.2 Considerations for Vacuum System

If a vacuum driven instrument is removed, the vacuum source must be capped and the system checked for leaks. See the aircraft specific maintenance manual for procedure.



The vacuum system and associated parts may be removed if there is no remaining need for vacuum. See the aircraft specific maintenance manual and AC 43.13-2B for guidance when removing the vacuum system. If the vacuum pump is removed, the engine accessory port must be properly covered. See specific engine maintenance and parts manuals for guidance.

### 3.4.3 Switches

There are no switches added by this STC installation.

### 3.4.4 Placards and Labels

All placards and labels should be readable in all lighting conditions. Ambient flood lighting is acceptable. The new circuit breaker installed for the G5 unit and supporting equipment must be labeled as noted in the interconnect drawings in Section 5. These labels are summarized in Table 3-8.

**Table 3-8: G5 and Supporting LRU Circuit Breaker Labels**

| Description             | Label                  |                      |
|-------------------------|------------------------|----------------------|
|                         | Single G5 Installation | Dual G5 Installation |
| G5 (Attitude Indicator) | ATT [1]                | ATT [1]              |
| G5 (DG/HSI)             | HSI or DG              | HSI or DG            |
| GMU 11                  | [2]                    | [2]                  |
| GAD 29/29B/29D          | GAD                    | GAD                  |
| GAD 13                  | [3]                    | [3]                  |

- [1] Circuit breaker is labeled “ATT” when the G5 is installed in the primary attitude position. When an existing primary attitude indicator is retained the G5 installed in the Turn Coordinator position should be labelled #2 ATT. Alternate spellings of “ATT” is acceptable.
- [2] When a single G5 is installed, the GMU 11 is powered from the same breaker as the G5. When two G5s are installed, the GMU 11 is powered from the same breaker as the G5 in the DG/HSI position.
- [3] If a GAD29(B)(D) is installed, the GAD 13 is powered from the same breaker as the GAD29(B)(D). When a GAD29(B)(D) is not installed, the GAD 13 is powered from an independent circuit breaker.

### 3.4.5 Cable and Wiring Considerations

Careful consideration must be given to the selection of wire type to be used for the CAN bus installation. There are two types of wire approved for CAN bus installations as part of this STC, 120Ω CAN cable or shielded twisted-pair cable, MIL-C-27500 (see Section 3.2.1).

It is recommended to use the 120Ω CAN cable for the following scenarios:

- If CAN bus lengths are expected to reach the maximum allowed. (see section 3.4.5.2)
- If there are future plans to install Garmin STC’s SA01866WI, Installation of Garmin GFC 500 Autopilot with Electronic Stability and Protection or SA01899WI, Installation of Garmin G3X Touch Electronic Flight Instrument System

If none of the above mentioned scenarios are a factor in the installation, use of shielded twisted-pair cable, MIL-C-27500 is acceptable.

For all other wiring selection considerations, select wire in accordance with AC 43.13-1B Chapter 11,

Sections 5 through 7. Mark wire in accordance with AC 43.13-1B Chapter 11 Section 16. Mark harness connectors in accordance with AC 43.13 Chapter 11 Section 17. Install wiring in accordance with AC 43.13-1B Chapter 11, Sections 8 through 13. Record the aircraft wire routing in Appendix C of *Garmin G5 Electronic Flight Instrument Part 23 AML STC Maintenance Manual including Instructions for Continued Airworthiness*, P/N 190-01112-11. Use the following guidelines to prevent damage to the aircraft and systems:

- Do not route the wire harness near flight control cables, high electrical capacity lines, high-energy sources or fuel lines.
- Locate the wire harness in a protected area of the aircraft.
- Make sure the wire harness does not come in contact with sources of high heat or be routed adjacent to RF coaxial cables.
- Make sure there is ample space for the wire harness and mating connectors.
- Avoid sharp bends.

### 3.4.5.1 Pressurized Aircraft Considerations

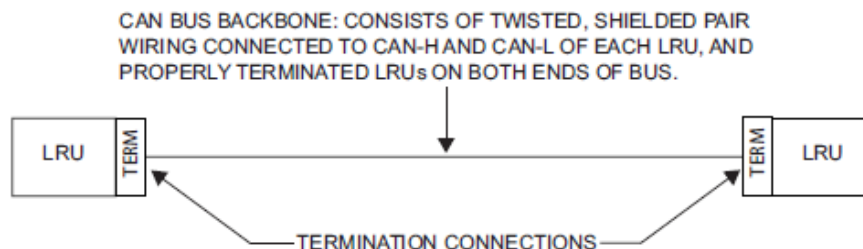
In pressurized aircraft, wiring that penetrates the pressure vessel must be installed in accordance with the Type Design of the aircraft. Any wires that penetrate the pressure bulkhead must use existing provisions such as spare pins in the existing bulkhead connectors, or existing sealed wire throughfares in accordance with the AMM. Substantiation for additional holes in the pressure vessel is beyond the scope of this manual and would require additional data from the aircraft manufacturer or other FAA approved data.

### 3.4.5.2 CAN Bus

The primary digital interface used to exchange data between the G5 Electronic Flight Instrument, GMU 11, GAD 29/29B/29D, and GAD 13 is the Controller Area Network, also known as the CAN bus. CAN was developed by Bosch GmbH in the 1980s, and its specifications are currently governed by ISO 11898-2. CAN is widely used in aviation, automotive, and industrial applications due to its simplicity and reliability.

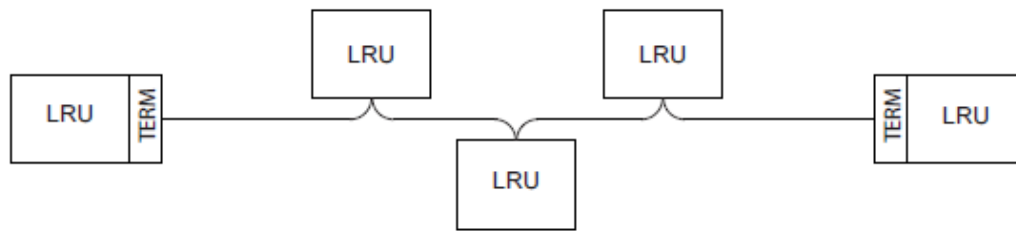
#### 3.4.5.2.1 CAN Bus Architecture

The electrical architecture of the CAN bus takes the form of a linear “backbone” consisting of a single twisted wire pair with an LRU connected (terminated) at each end (Figure 3-1). The installer should attempt to make this “backbone” as short as practical. **The maximum overall length of the CAN bus from end to end should be 85 feet.** At each of the two extreme ends of the CAN bus, a 120Ω resistor is installed to “terminate” the bus. Termination resistors are either provided via termination adapters that plug into an LRU’s CAN connection or are internal to the LRU.



**Figure 3-1 CAN Bus Backbone**

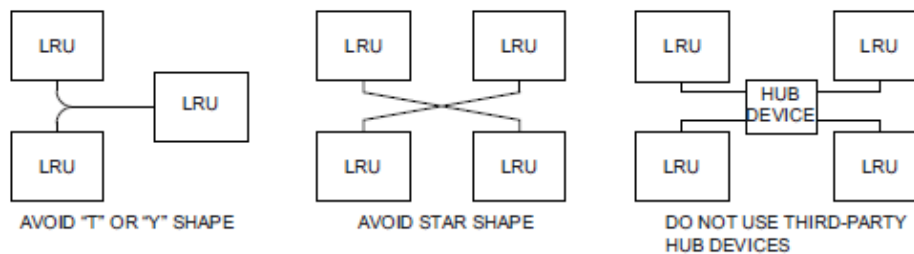
Multiple LRU’s may be connected in a daisy chain manner along the backbone of the CAN bus (Figure 3-2).



**Figure 3-2 Correct CAN Bus Wiring Example and Node Connections**

Daisy-chained LRUs (LRUs not at the extreme ends of the CAN bus) connect to the CAN backbone through short “stub” or “node” connections (Figure 3-2). The length of each node connection should be 3 inches or less, the maximum allowed distance from a splice to a connector, unless otherwise specified.

Multiple devices must not connect to the CAN bus backbone at the same point. Rather than splicing two or more stub node connections together, the CAN bus should instead be daisy-chained from one device to the next (Figure 3-2).



**Figure 3-3 Incorrect CAN Wiring Example**

### 3.4.5.2.2 CAN Bus Wiring

CAN bus wiring must only be connected to Garmin LRUs. All new installations must use 120Ω CAN bus cable (see Section 3.2.1) or shielded twisted-pair cable, MIL-C-27500. The shields for each CAN bus wire segment must be interconnected, forming a continuously connected shield from one end of the CAN bus to the other end of the CAN bus. The CAN bus shield must always be grounded to the device connector backshells on all devices connected to the CAN bus.

### 3.4.5.2.3 CAN Bus Termination

At each of the two extreme ends of the CAN bus backbone, a 120Ω resistor is installed to terminate the bus. Termination resistors are provided either via termination adapters that plug into an LRU’s CAN connection or a resistor internal to the LRU.

- The G5, GMU 11, and GAD 13 connector kits provide a 9-pin termination adapter that provides termination when attached to the device’s main connector. The termination adapter contains a 120Ω resistor that is connected between pins 1 and 2 (Figure 3-4).
- The GAD 29/29B/29D contains a 120Ω resistor inside the unit that provides termination when the two CAN TERM pins are connected together (Figure 3-5). Alternatively, the GAD 29/29B/29D can be terminated externally using a termination adapter, Garmin P/N 011-02887-00 (Figure 3-4).

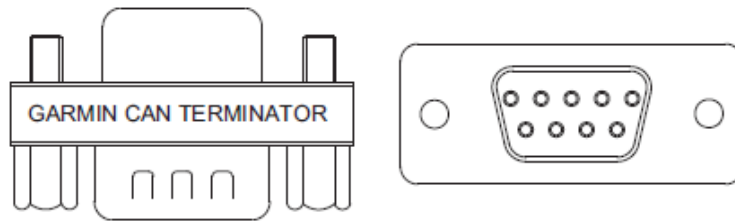


Figure 3-4 CAN Bus Termination (011-02887-00) for G5, GMU 11, and GAD 13

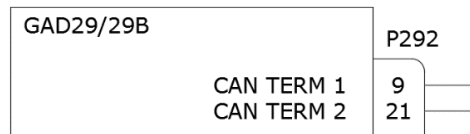


Figure 3-5 CAN Bus Termination for GAD 29/29B/29D

Both ends of the CAN bus must have a CAN bus terminator installed (Figure 3-2), but devices that are not at the ends of the CAN bus should not have a CAN bus terminator installed.

#### 3.4.5.2.4 CAN Bus Installation Guidelines

For maximum reliability of the CAN bus, the following guidelines should be followed:

- The CAN bus backbone must be a single linear path with exactly two distinct ends. CAN bus connections should be “daisy chained” from device to device. Avoid “star” and “Y” topologies, and do not use a hub device (see Figure 3-3).
- **The overall length of the bus should not exceed 85 feet.**
- Do not connect more than one device to the CAN bus backbone at the same point. Instead, daisy chain the CAN bus backbone from one device to the next.
- Observe proper wiring, shielding, and grounding requirements as described above.
- Terminate the CAN bus at the two extreme ends of the bus, as described above.
- When adding a new device to the CAN bus, evaluate proposed modifications to the CAN bus wiring connections to ensure compliance with all above requirements.

#### 3.4.5.3 Coaxial Cable Considerations

When routing coaxial cables, observe the following precautions:

- Avoid sharp bends.
- Avoid routing cables near power sources (e.g. 400 Hz generators, trim motors, etc.) nor near power for fluorescent lighting.
- For excess coax cable, coil as necessary and use cable ties to secure coil. Do not attempt to shorten the pre-installed lead on the Glare Shield Mounted GPS Antenna.

#### 3.4.6 Cooling Requirements

While no forced cooling air is required for the G5, GMU 11, GAD 29/29B/29D, or GAD 13 it is highly recommended that the air behind the panel be kept moving (by ventilation or a fan). Units tightly packed in the avionics stack heat each other through radiation, convection, and sometimes by direct conduction. Even a single unit operates at a much higher temperature in still air than in moving air. Fans or some other means of moving the air around electronic equipment are usually a worthwhile investment.





## NOTE

Avoid installing LRUs near heat sources. If this is not possible, ensure that additional cooling is provided. Allow adequate space for installation of cables and connectors. The installer will supply and fabricate all of the cables. Install wiring in accordance with FAA AC 43.13-1B and AC 43.13-2B.

### 3.4.7 Compass Safe Distance

After reconfiguring the avionics in the cockpit panel, if the unit is mounted less than 12 inches from the compass, recalibrate the compass and make the necessary changes for noting correction data.

### 3.4.8 Shield Termination Considerations

For G5 installations utilizing the RS-232, CAN bus, and ARINC 429 interfaces, terminate the shield to the G5, GMU 11, GAD 29/29B/29D, and GAD 13 connector backshells as shown in Figure 4-49, Figure 4-50, and Figure 4-51. For shield terminations at the GPS or VHF Navigator follow the appropriate installation techniques as indicated by the manufacturers installation instructions for that unit. If there are any interposing connectors then the shields must have continuity through the interposing connector. This can be achieved by:

- 1) Terminating the shields to the backshell of the connector if both mating connectors and both backshells are metal.
- 2) Terminating the shield to aircraft ground directly
- 3) Passing the shield through pins in the connector. This is the least preferred method.

### 3.4.9 Audio Interference

This STC installation does not interface to audio signals. Attention to harness installation and routing as specified in Section 3.4.5 should be considered for Audio interference mitigation.

### 3.4.10 GAD 29B/29D Transformer Mounting Instructions

For GAD 29B/29D installations interfacing with certain Century, Cessna, and Piper autopilots an inline transformer may be required. Refer to Section 5.24 for further information on specific autopilots. Solder transformer leads to the appropriate wire per SAE AS4461, and cover with heat shrink that extends the entire lead of the transformer and at least 0.5 inch of the insulated wire. Do this for each transformer lead and then cover the entire assembly with heat shrink, extending at least 1 inch past the solder connections.

This assembly must then be secured to the existing aircraft wiring harness near the GAD 29B/29D to reduce strain on the components. Secure using a minimum of two cable ties, one over the body of the transformer and one near the solder joints.

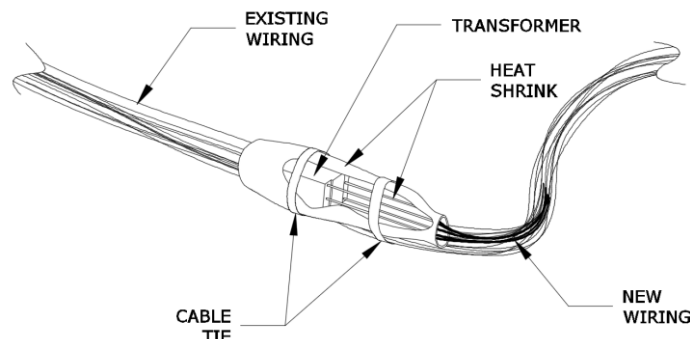


Figure 3-6 GAD 29B/29D Inline Transformer Mounting Instructions



## 4 INSTALLATION PROCEDURES

### 4.1 Mechanical Installation

#### 4.1.1 Special Tools Required

##### **Laser Square**

For GMU 11 magnetometer installations it is recommended (but optional) to use a laser square with a line accuracy of  $\pm 3/32$  inches end-to-end, at 15 feet perpendicular distance (or better). A Stanley Laser Level Square 77-188 S2 meets the line accuracy requirement.

##### **Digital Level**

It is recommended to use a digital level when installing GMU 11 magnetometer.

##### **Protractor Tool**

A protractor tool may be required to measure the angle offset during the magnetometer installation.

##### **Plumb Bob**

A plumb bob may be required for leveling and installing the magnetometer unit.

##### **Aircraft Jack Set**

A set of aircraft jacks may be required for stabilizing the aircraft after it is leveled.

#### 4.1.2 G5 Mounting Requirements



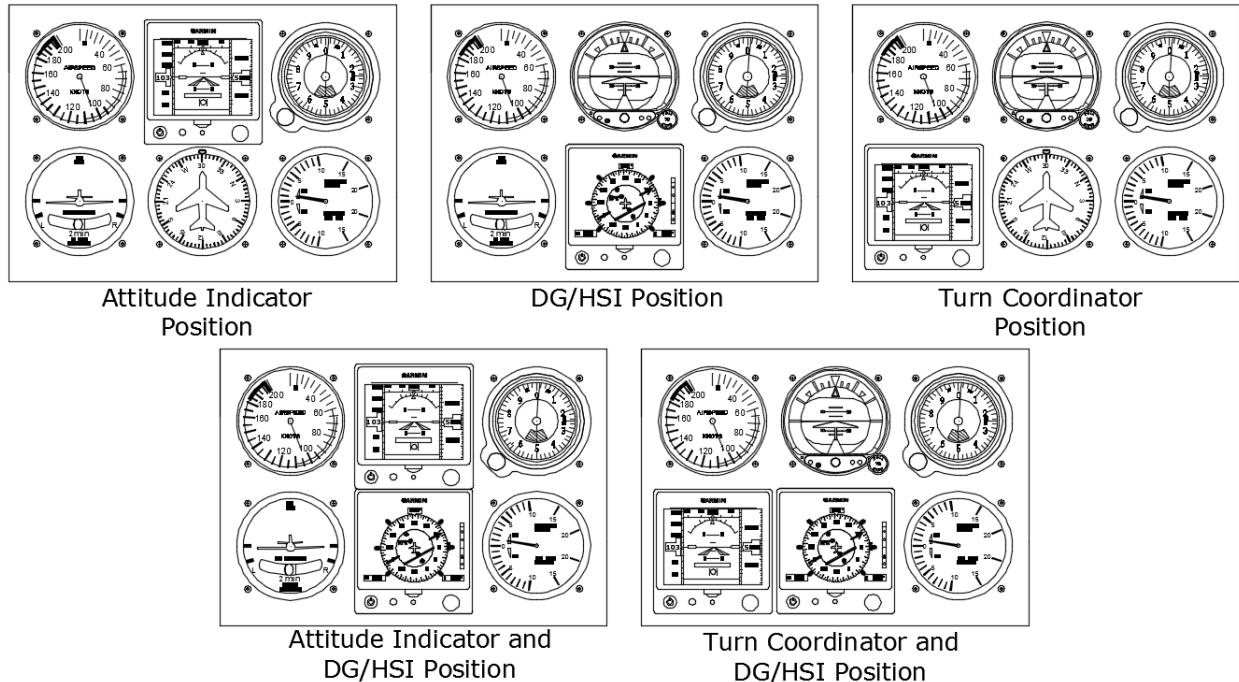
##### **NOTE**

*It is important that the G5 is installed perpendicular to the aircraft's longitudinal axis (display bezel parallel to the wing spar carry thru) and as close to level in the roll axis as possible. Small roll offsets and pitch offsets, up to 15°, can be corrected for during calibration.*

In addition to the installation limitations in Section 2.1, consider the following when selecting a mounting location for the G5:

- Protect the mounting location for the G5 from rapid thermal transients, in particular large heat loads from nearby high-power equipment.
- Do not install the G5 within 1 inch of magnetically mounted antennas, speaker magnets, or other strongly magnetic items.
- If installing dual G5s above and below each other, a minimum spacing of 3.6 inches center to center is required, see Section 4.1.2.4 for more information.
- Two Adapter Plates must be used if installing the G5 in an instrument hole with any cutout for instruments knobs. See Figure 4-10 and Figure 4-12 for more information.

One or two G5s may be installed. See Figure 4-1 for typical installation configurations in an IFR approved aircraft.



**Figure 4-1 Typical G5 Installations for IFR Approved Aircraft**

A G5 can be installed in an instrument panel that does not have an existing attitude indicator or DG/HSI. In these cases, the G5 must be located on the Pilot's instrument panel, and centered as nearly as practicable about the vertical plane of the pilot's forward vision. If the G5 is installed as an;

- Attitude indicator, it must be located as close to the top center position of the pilot's instrument panel as practical.
- DG/HSI, it shall be located adjacent to and directly below the instrument in the top center position when possible.

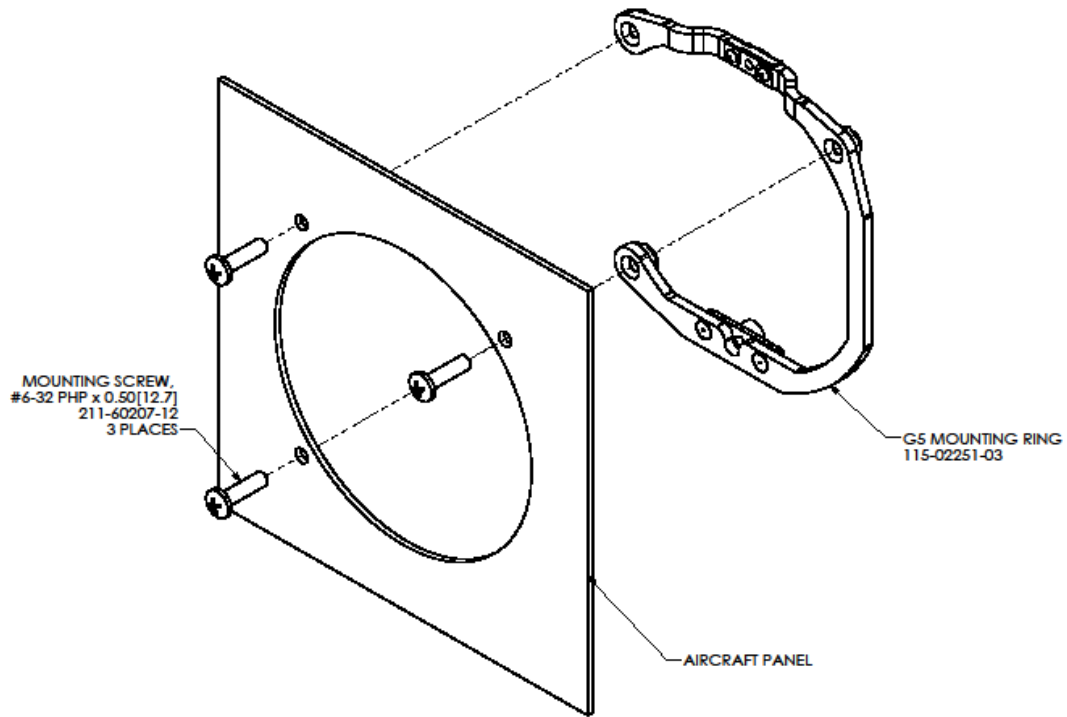
#### 4.1.2.1 Mounting Ring Installation

The G5 Mounting Ring (115-02251-03) can be used as a template when marking the panel for cutout. For complete cutout dimensions see Figure 6-15.

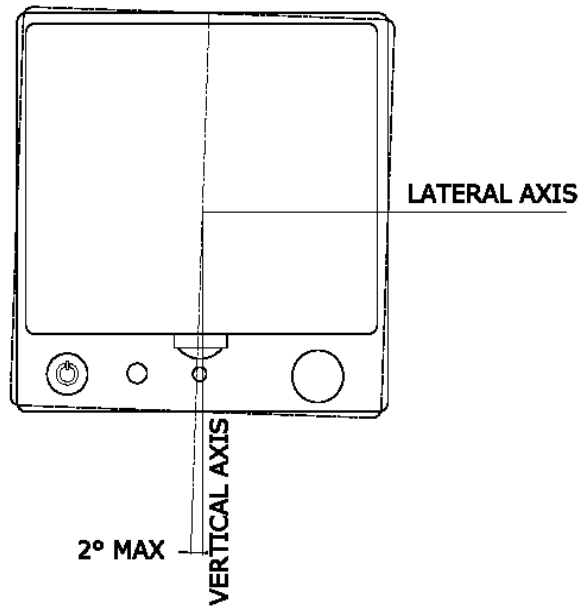
Secure the mounting ring to the aircraft panel using the supplied #6-32 pan head Phillips mounting screws. Evenly torque the mounting screws to 10-12 in-lbs.

- The G5 must be leveled to within 15.0° in the longitudinal axis (Pitch). (Reference Figure 4-4 )
- The G5 must be leveled to within 2.0° in the lateral axis (Roll). (Reference Figure 4-3 )
- Mount the G5 with the connector aligned to within 1.0° of the vertical axis (Yaw) of the aircraft (display bezel parallel to the wing spar carry thru). (Reference Figure 4-5 )

An aircraft leveling and offset calibration procedure must additionally be carried out prior to flight.



**Figure 4-2 G5 Mounting Ring**



**Figure 4-3 Maximum Misalignment of the G5 in the Lateral Axis**

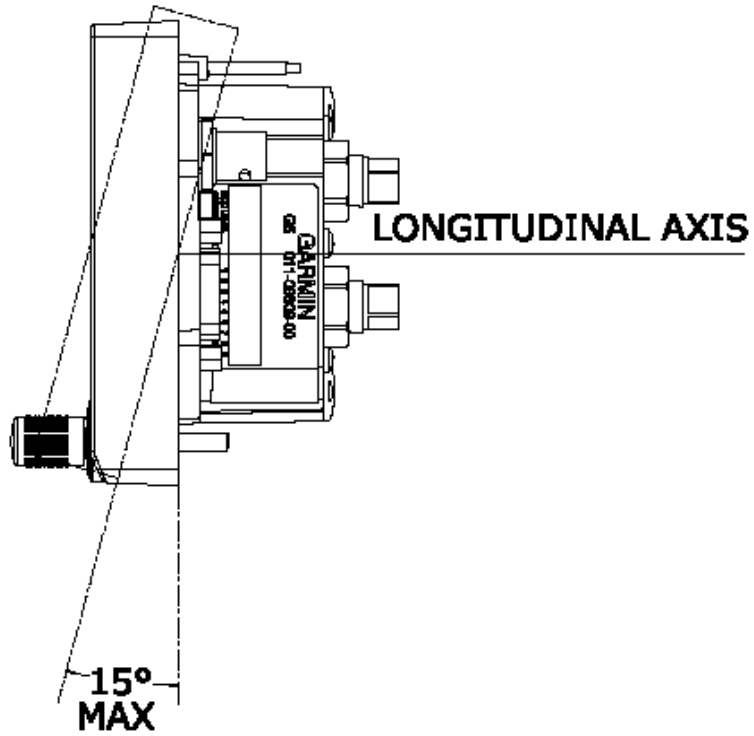


Figure 4-4 Maximum Misalignment of the G5 in the Longitudinal Axis

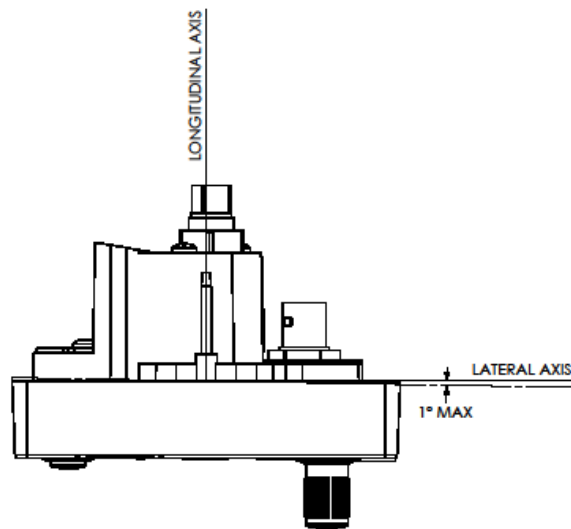


Figure 4-5 Maximum Misalignment of the G5 in the Vertical Axis

## 4.1.2.2 G5 Installation

The G5 is installed by inserting the alignment pin located at the top of the unit into the mating hole in the mounting ring, pushing the unit flush with the instrument panel, and fastening the captive 3/32" hex socket head screw to the mounting ring as shown in Figure 4-6. To fasten the captive screw to the mounting ring, insert a 3/32" hex drive tool through the access hole in the front cover of the G5 as shown in Figure 4-7. Torque the captive mounting screw to 10-12 in-lbs.

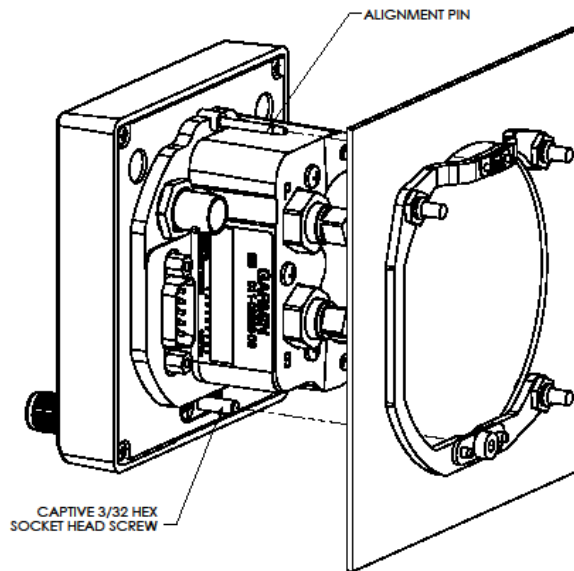


Figure 4-6 G5 Alignment Pin

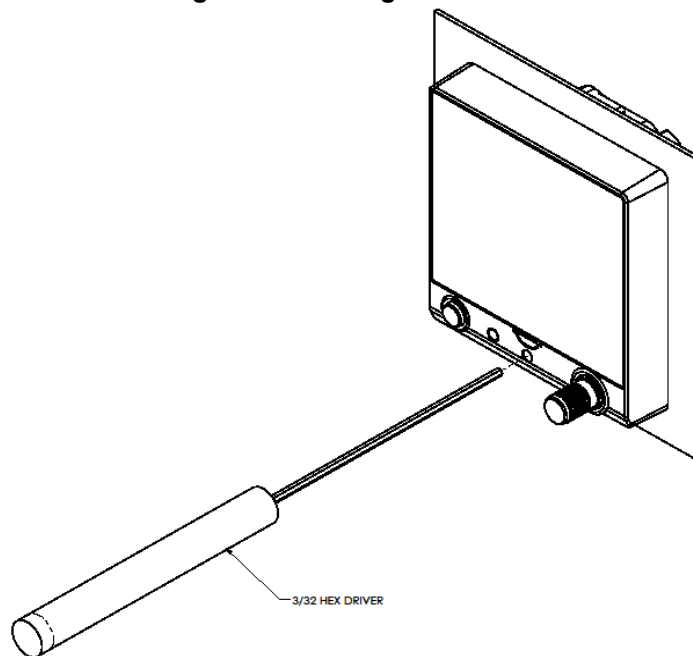


Figure 4-7 G5 Hex Driver Insertion

## 4.1.2.3 Optional #6-32 Captive Mounting Screw

The captive 3/32" hex socket head screw can be used for panel thicknesses up to 0.150". For installations with a panel thickness greater than 0.150", the captive mounting screw can be replaced with a standard #6-32 hex socket head screw (MS16995). To replace the screw, remove the two #4-40 flat head Phillips mount plate screws, the G5 screw mount plate, and the captive screw as shown in Figure 4-8. Reverse this process to install the longer #6-32 hex socket head screw. Ensure correct orientation of the screw mount plate before applying 6-8 in-lb. of torque to the #4-40 mount plate screws.

NOTE: Standard #6-32 hex socket head screws use a 7/64" hex drive feature. The access hole in the G5 bezel is large enough to accommodate this increase in hex tool size.

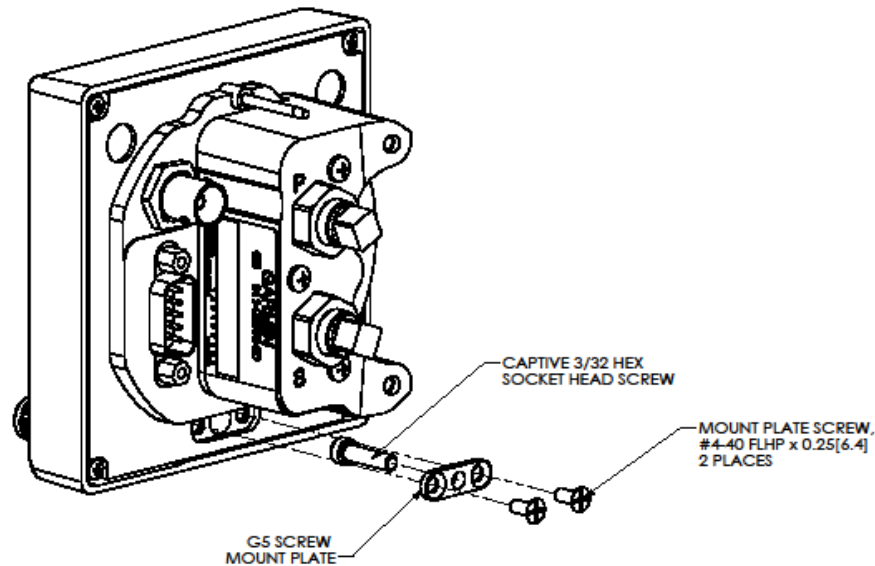
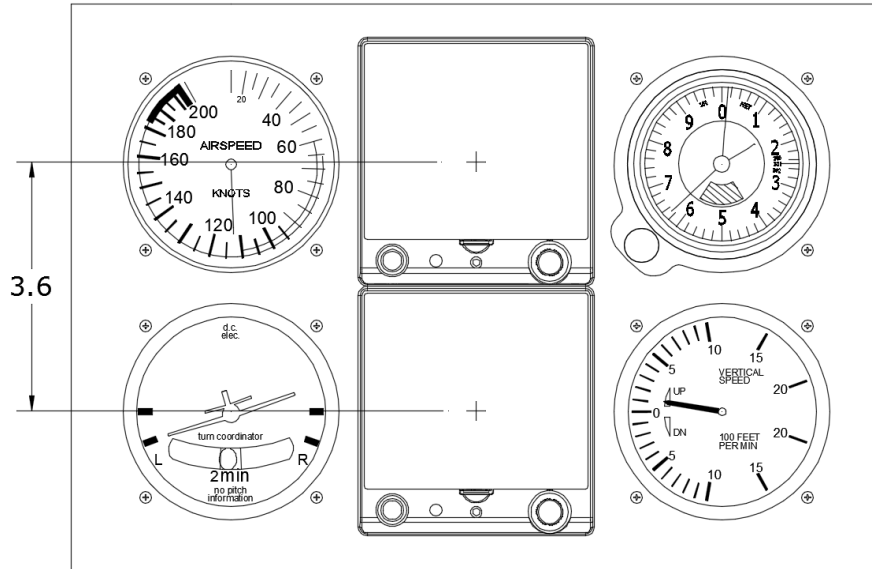


Figure 4-8 G5 Captive Mounting Screw Replacement

*This area intentionally blank*

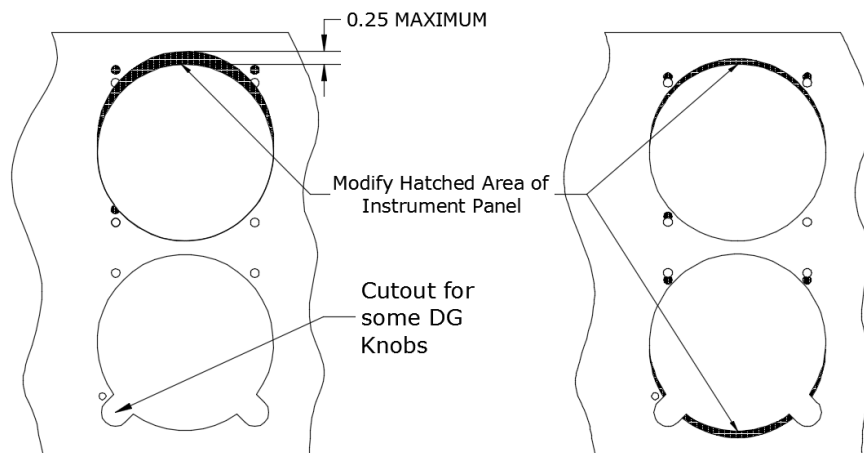
## 4.1.2.4 Dual G5 Installations Requiring Instrument Panel Modification

The minimum vertical distance needed between two G5 units is 3.6 inches center to center. Some instrument panels may require modification of existing holes to gain the needed 3.6 inch spacing.



**Figure 4-9 Required Vertical Spacing Between G5 Units**

The panel may be modified by enlarging one hole or both, up to a maximum of 0.25 inch per instrument hole. The proposed positions must be such that neither G5 unit is obscured by the glare shield, control yoke or other object.



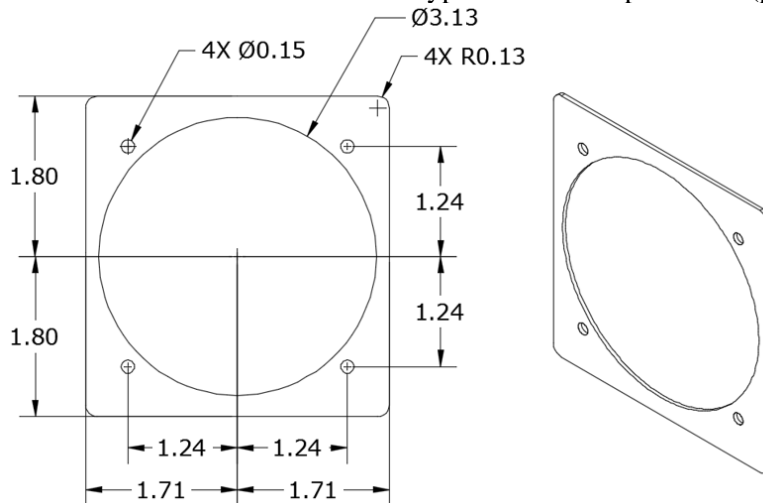
**Figure 4-10 Instrument Panel Modification**



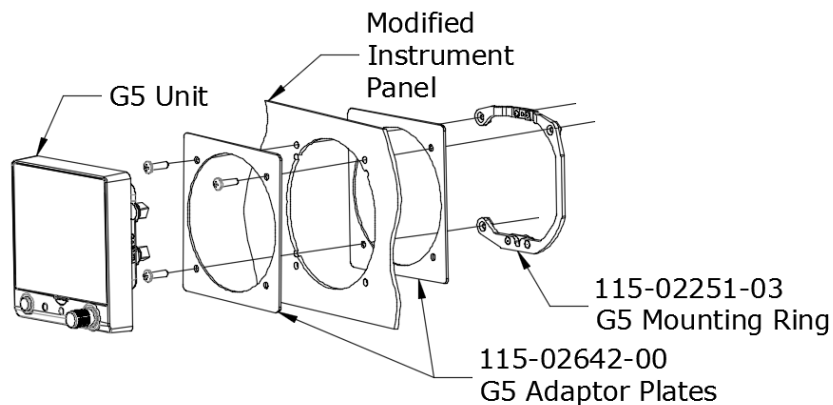
The G5 Adapter Plate, (115-02642-00) is shown in Figure 4-11. Each installation of a G5 in a DG/HSI will include 2 adapter plates. Two G5 adapter plates must be installed as shown in Figure 4-12 when

- any instrument panel modification has taken place
- G5 is installed in an instrument hole with cutouts for instrument knobs

The G5 adapter plate is fabricated from 0.050 thick 2024-T3 aluminum per the dimensions shown in Figure 4-11. Apply a finish coat of paint to adaptor plates as desired prior to final installation. These may be field fabricated if needed and must have some type of corrosion protection (primer, alodine, etc.).



**Figure 4-11 G5 Adapter Plate**



**Figure 4-12 G5 Adapter Plate Assembly**

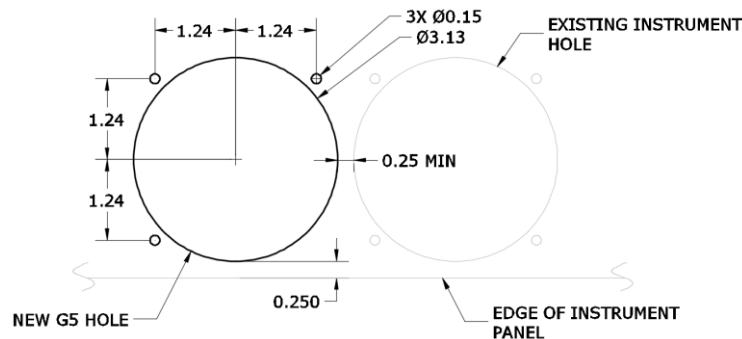
#### 4.1.2.5 Cutting a New Instrument Hole for G5 Installation

For G5 installations in aircraft approved for VFR-only operation, there may be the need to cut a new instrument hole.

If it is desired to mount the G5 recessed, refer to Section 4.1.2.6 for instructions and limitations.

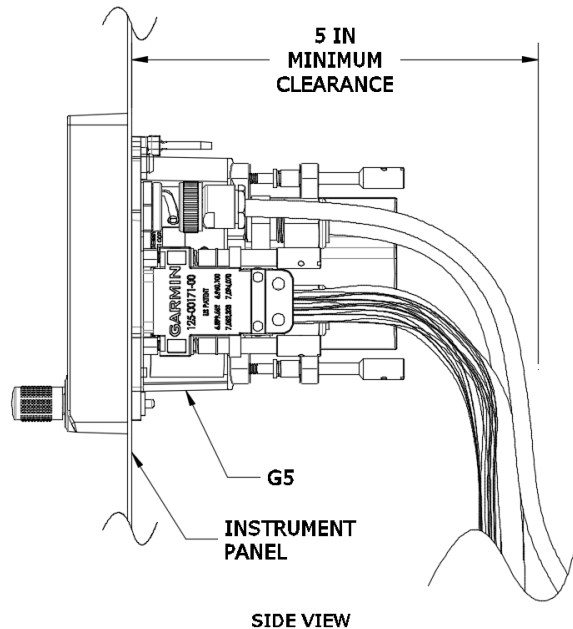
In order to satisfy the structural requirements when cutting a new instrument hole in the existing panel, the following conditions must be met:

- 1) Modification of the instrument panel must be in accordance with AC 43.13-2B, Chapter 2.
- 2) The instrument panel must be a minimum of 0.040 inches thick.
- 3) The dimensions and limitations of the hole must be as shown in Figure 4-13.
- 4) The new location must satisfy the alignment requirements shown in Figure 4-3, Figure 4-4, and Figure 4-5.
- 5) There must be at least 0.25 inches between the main instrument hole or the screw holes and any adjacent holes or the edges of the panel.
- 6) The instrument panel must be structurally capable of supporting the weight of the installed units.
- 7) The location of the hole must allow for sufficient clearance for the G5 electrical and pneumatic connections, see Figure 4-14.
- 8) The location must be free from rapid thermal transients, in particular, large heat loads from electrical loads.
- 9) Do not mount the G5 within 1 inch of magnetically mounted antennas, speaker magnets, or other strongly magnetic items.



**Figure 4-13 G5 Instrument Hole Dimensions**

*This area intentionally blank*

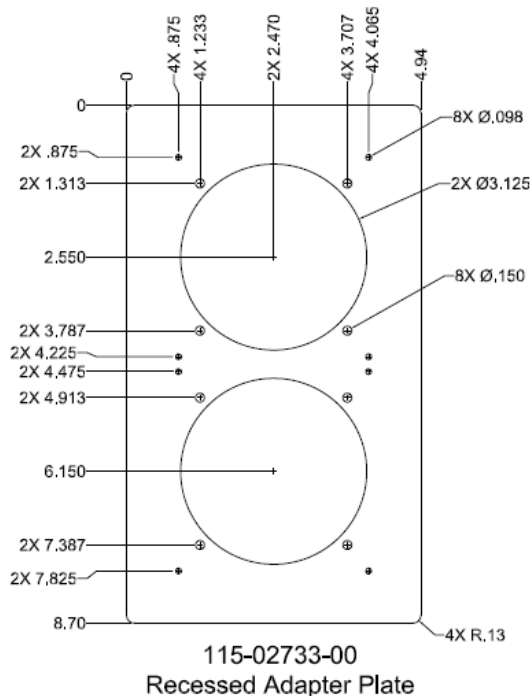


SIDE VIEW

**Figure 4-14 Clearance for Connections**

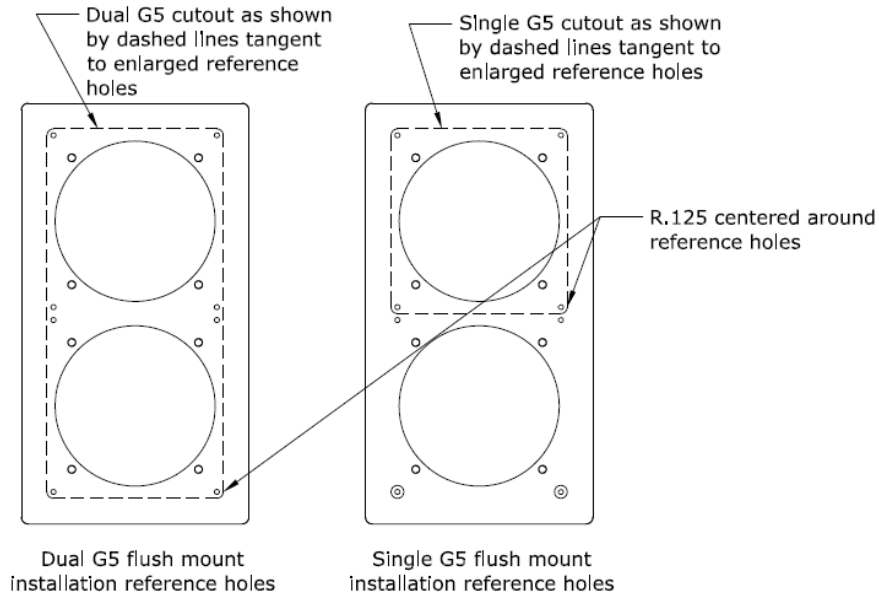
#### 4.1.2.6 G5 Recessed Mount Option

The G5 unit may be recessed into the instrument panel which positions the display flush with the instrument panel. A full understanding of this modification is required before starting. A recessed adapter plate and modification of the instrument panel will be needed. Some instrument panels may not be capable of supporting this modification. See section 4.1.2.6.5 for suggested adapter plate modification procedure.



**Figure 4-15 Recessed Adapter Plate**

Recessed Adapter Plate, 115-02733-00, is required when a G5 unit is recessed in the panel. The plate can be ordered from Garmin, or field fabricated. If field fabricated, it must be 0.090 thick 2024-T3 aluminum per Figure 4-15 and must have some type of corrosion protection (primer, alodine, etc.). The Recessed Adapter Plate includes reference holes and can be used as a template for creating the recessed cutout.

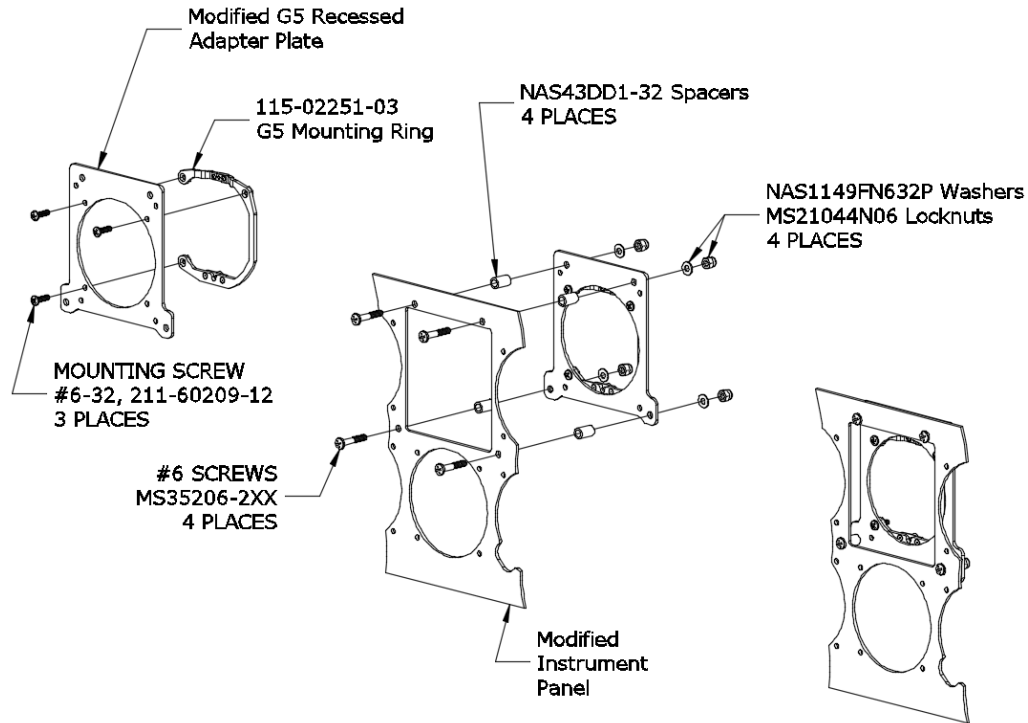


**Figure 4-16 Recessed Adapter Plate Template Reference Holes**

#### 4.1.2.6.1 Recess Mounting Single G5

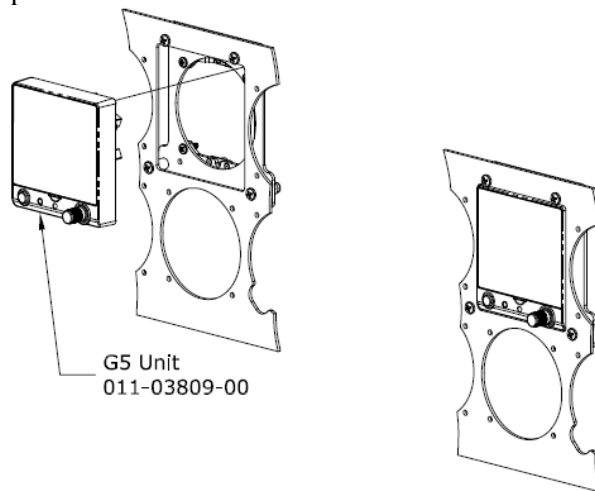
Install a single recessed G5 as illustrated by Figure 4-17 and Figure 4-18. A G5 installation in the attitude position is shown, but the same instructions can be used when installing a G5 in the DG or turn coordinator positions. Modify 115-02733-00 adapter for single G5 installation per Figure 4-16. A minimum of four No. 6 MS35206-2XX screws must be used to secure the modified mounting adapter plate in place. Maintain 1.5D edge distance minimum.

*This area intentionally blank*



**Figure 4-17 Single G5 Recessed Adapter Plate Installation**

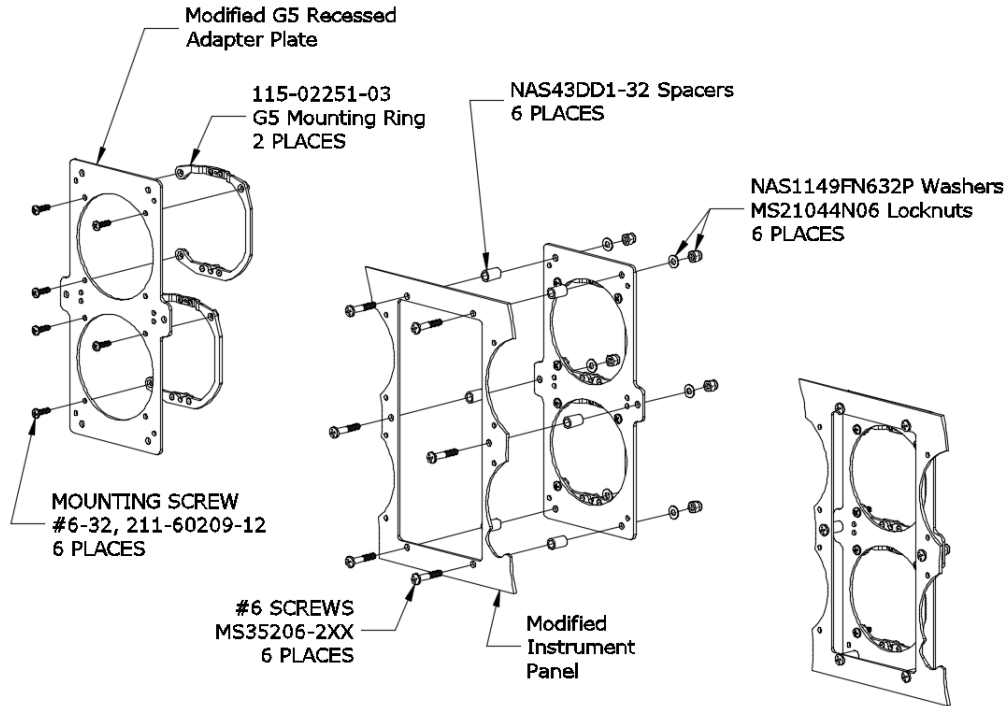
Install G5 unit per section 4.1.2.2.



**Figure 4-18 Single G5 Recessed Installation**

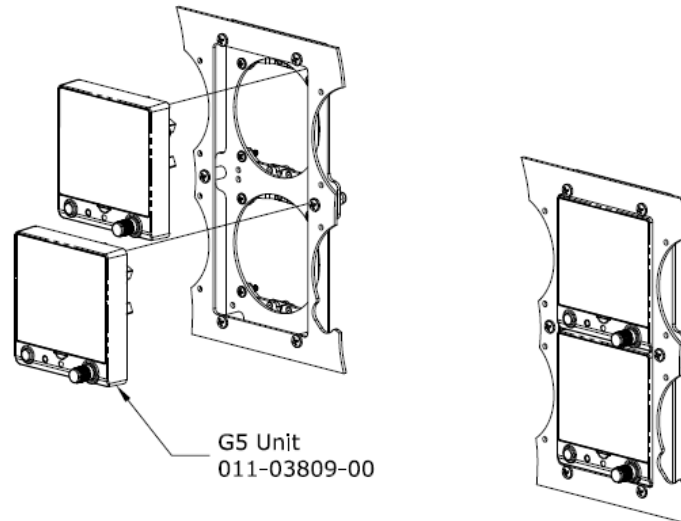
## 4.1.2.6.2 Recess Mounting Dual G5 Vertically

Install dual recessed G5s as illustrated by Figure 4-19 and Figure 4-20. A minimum of six No. 6 MS35206-2XX screws must be used to secure the modified mounting adapter plate in place. Maintain 1.5D edge distance minimum.



**Figure 4-19 Dual Vertical G5 Recessed Adapter Plate Installation**

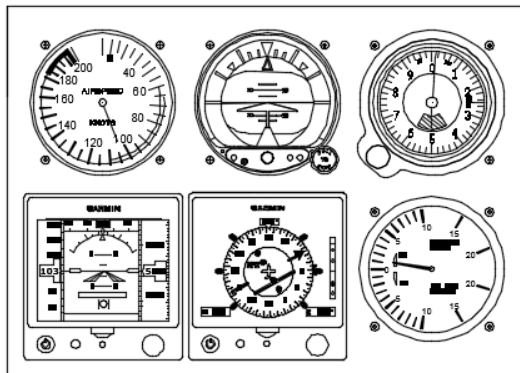
Install G5 units per section 4.1.2.2.



**Figure 4-20 Dual Vertical G5 Recessed Installation**

## 4.1.2.6.3 Recess Mounting Dual G5 Horizontally

In an installation where the G5 Attitude indicator is in the Turn Coordinator position and a G5 DG/HSI is installed as well (ref Figure 4-21), the dual G5s may be installed recessed horizontally in a similar manner to the dual vertical recessed installation. A horizontal recessed adapter plate will need to be field fabricated in order to fit the existing installation. This plate must be fabricated of 0.090 thick 2024-T3 aluminum and must have some type of corrosion protection (primer, alodine, etc.). A minimum of six No. 6, MS35206-2XX screws must be used to secure the modified mounting adapter plate in place. Maintain 1.5D edge distance minimum.



Turn Coordinator and  
DG/HSI Position

Figure 4-21 Dual Horizontal G5 Recessed Installation

*This area intentionally blank*

#### 4.1.2.6.4 Instrument Panel Modification Limitations

The modification required for recess mounting a G5, whether it is single, dual vertical or dual horizontal must meet the following conditions:

- 1) The mounting location must satisfy the alignment requirements shown in Figure 4-3, Figure 4-4, Figure 4-5.
- 2) The proposed location must allow for sufficient clearance for the G5 unit and connections as shown in Figure 4-14.
- 3) The hole must meet the limitations and minimums as shown in Figure 4-22.
- 4) The modification must be completed in accordance with AC 43.13-2B, Chapter 2.

Any modification of subsequent structure or parts other than the instrument panel as defined in these instructions are beyond the scope of this manual. Additional data from the aircraft manufacturer or other FAA approved data would be required for these situations.

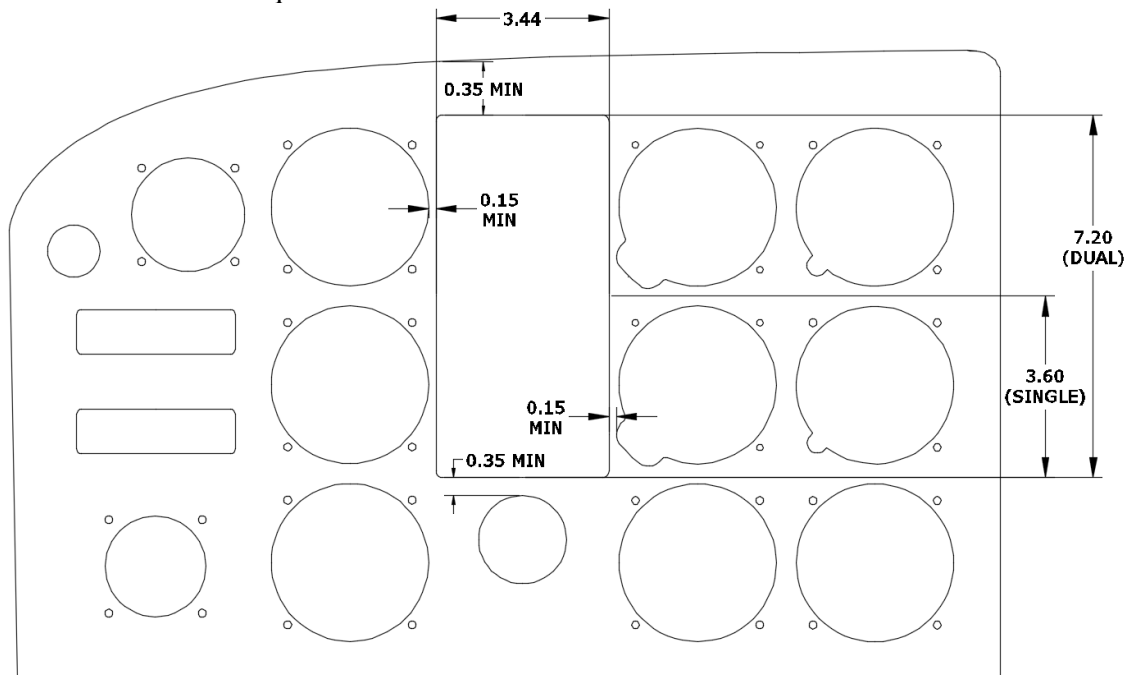


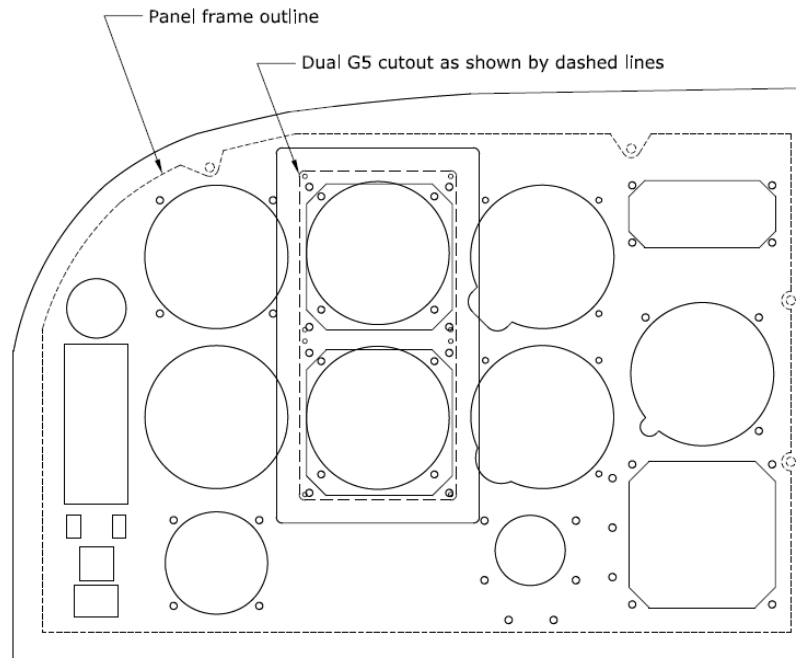
Figure 4-22 Instrument Panel Limitations

#### 4.1.2.6.5 Modifying Recess Mount Adapter Plate

This section illustrates a suggested procedure for modifying the G5 Recessed Adapter Plate and instrument panel. Dual vertical G5 installation shown; dual horizontal and single installation procedure is similar.

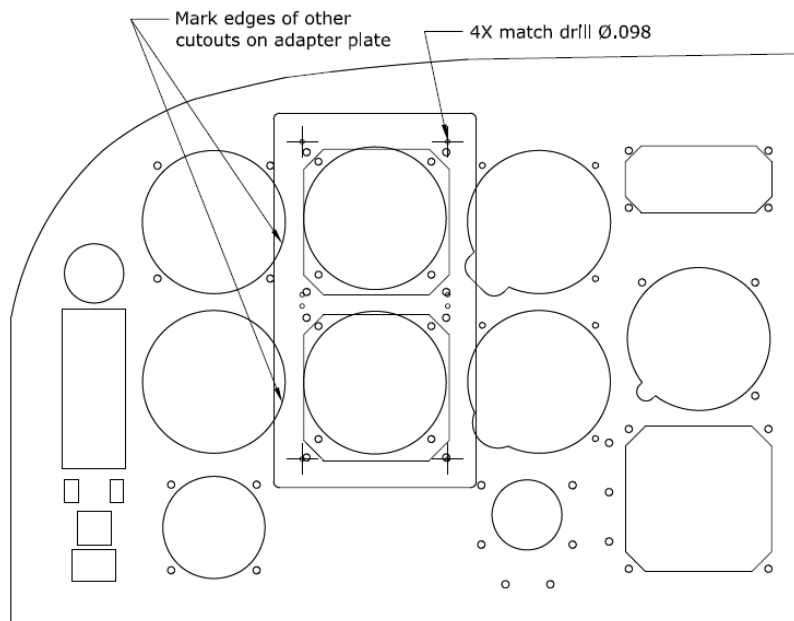






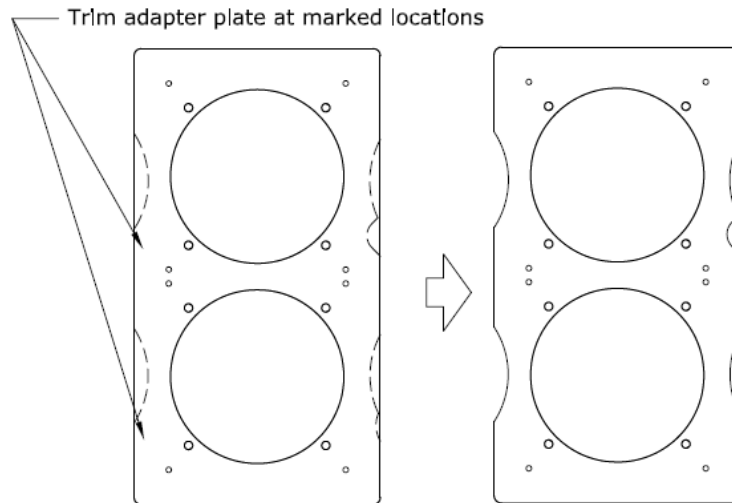
**Figure 4-25 Recessed Adapter Plate Located on Panel**

Place 115-02733-00, Recessed Adapter Plate, at desired location, keeping in mind distance to instrument panel frame and other instruments.

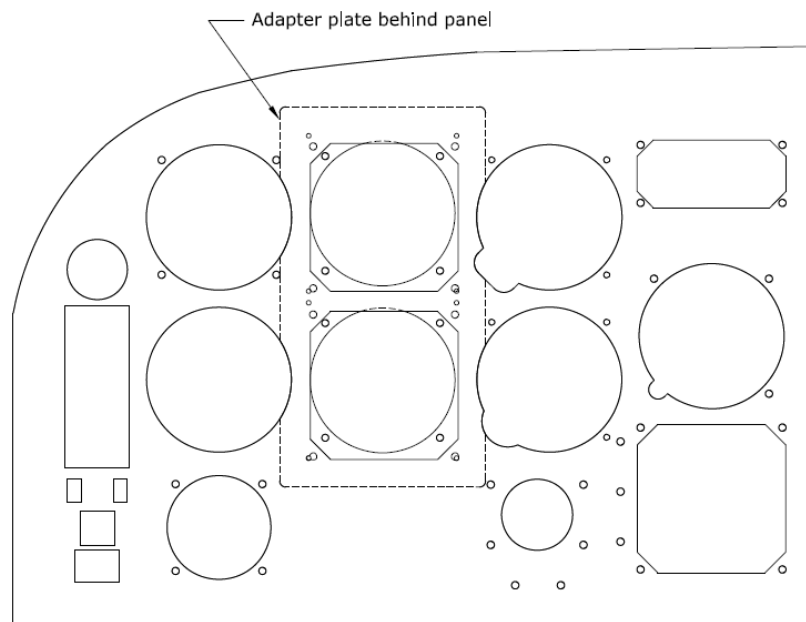


**Figure 4-26 Match Drilling Through Panel - Using Adapter Plate as Template**

When ready, mark adapter plate and match drill instrument panel 4x, .098 diameter through adapter plate reference holes

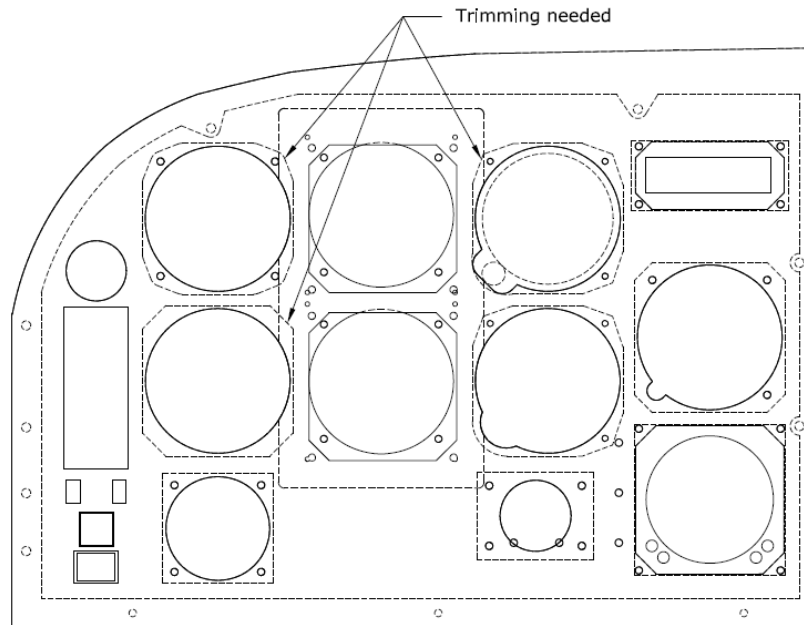


**Figure 4-27 Preliminary Trimming of Adapter Plate**



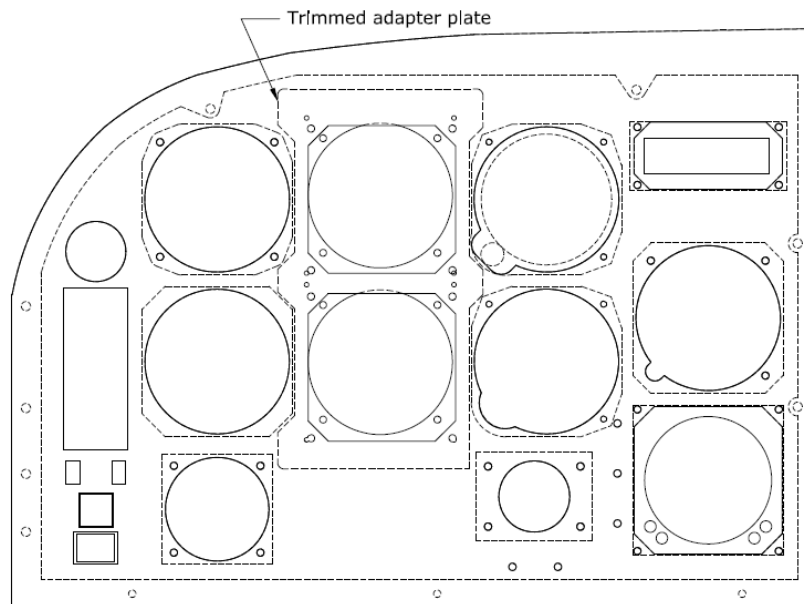
**Figure 4-28 Adapter Plate Located on Far Side of Instrument Panel**

Use reference holes from adapter plate to align adapter plate behind panel.



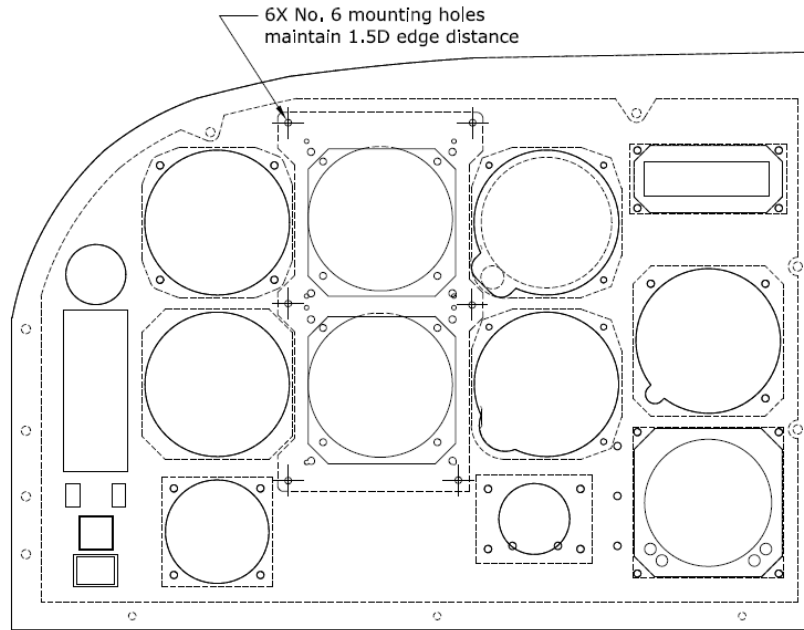
**Figure 4-29 Additional Trimming of Adapter Plate Required**

Mark adapter plate where trimming is needed in order to avoid interference with any adjacent instrument or other item.



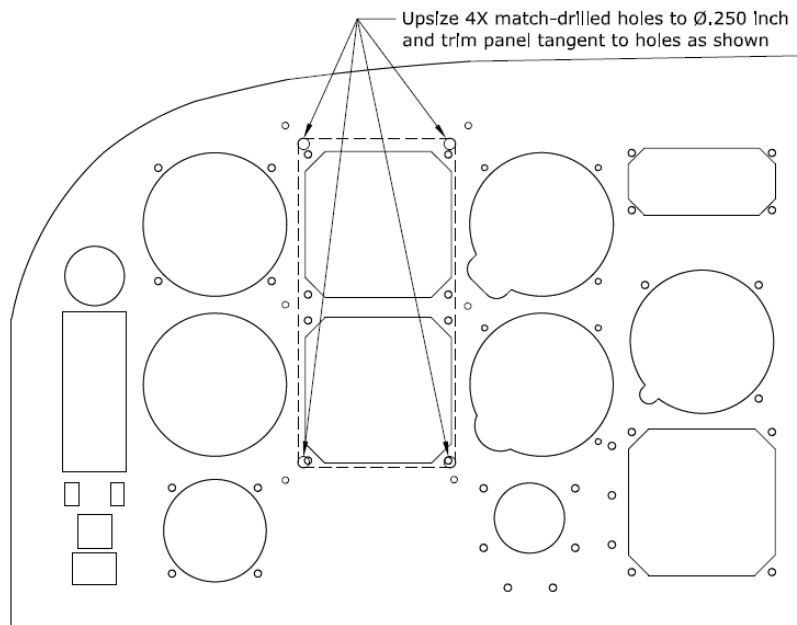
**Figure 4-30 Trimmed Adapter Plate**

Trim adapter plate as needed; remove only enough material to allow adapter plate to fit without interference.

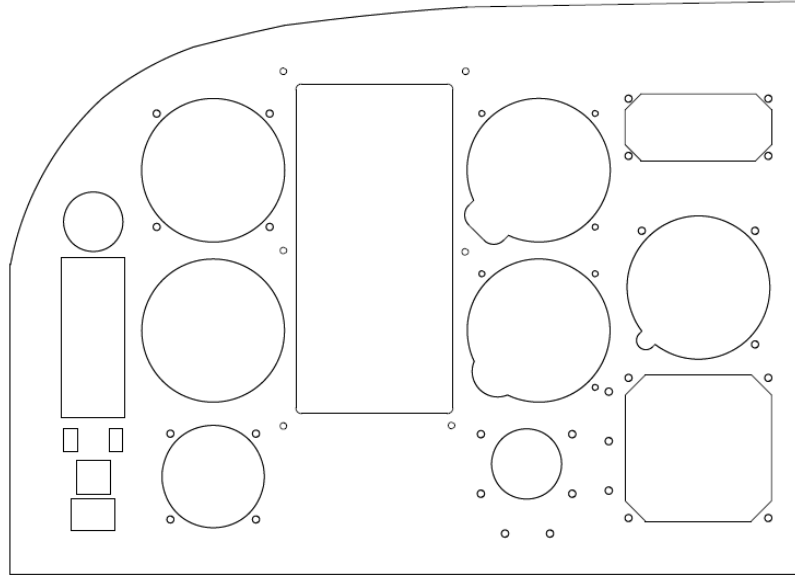


**Figure 4-31 Adapter Plate Mounting Holes**

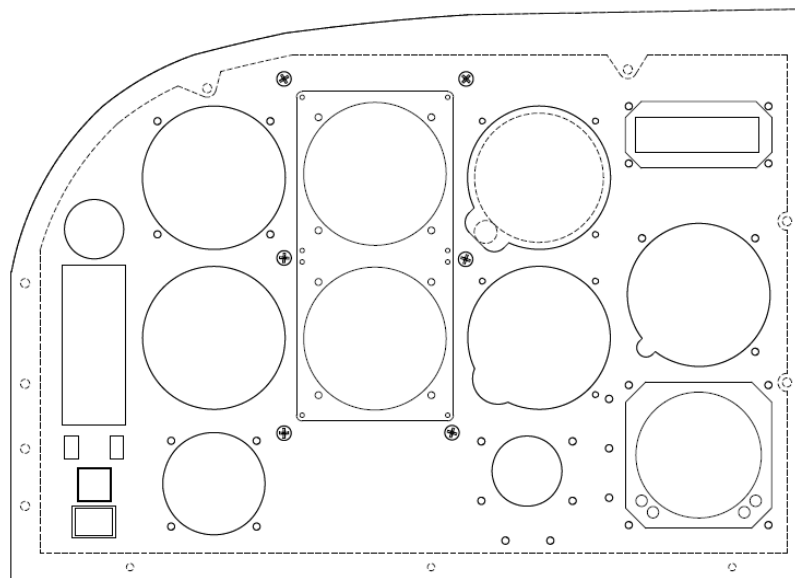
Drill 6 mounting holes through both adapter plate and panel; maintain minimum 1.5D edge distance for No. 6 hardware.



**Figure 4-32 Dual G5 Panel Cutout - Using Match Drilled Holes for Reference**

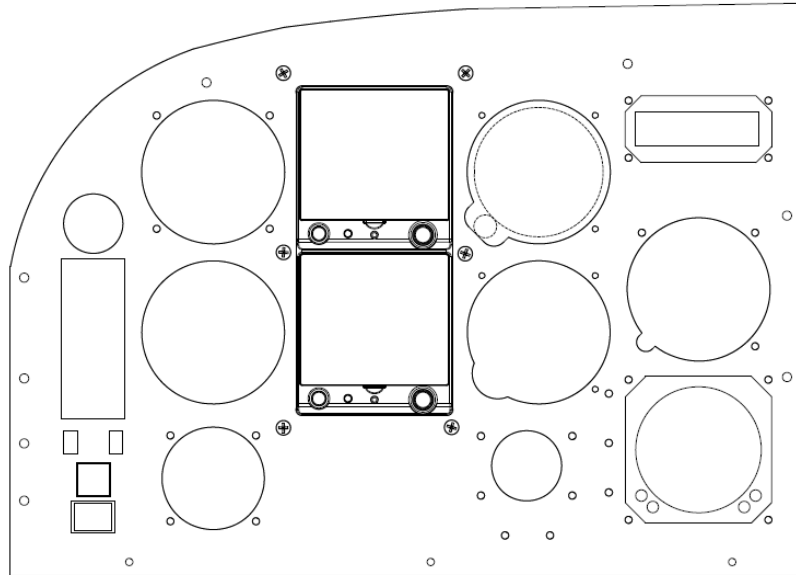


**Figure 4-33 Instrument Panel After Cutout for Dual Vertical G5 Units**



**Figure 4-34 Adapter Plate Installed**

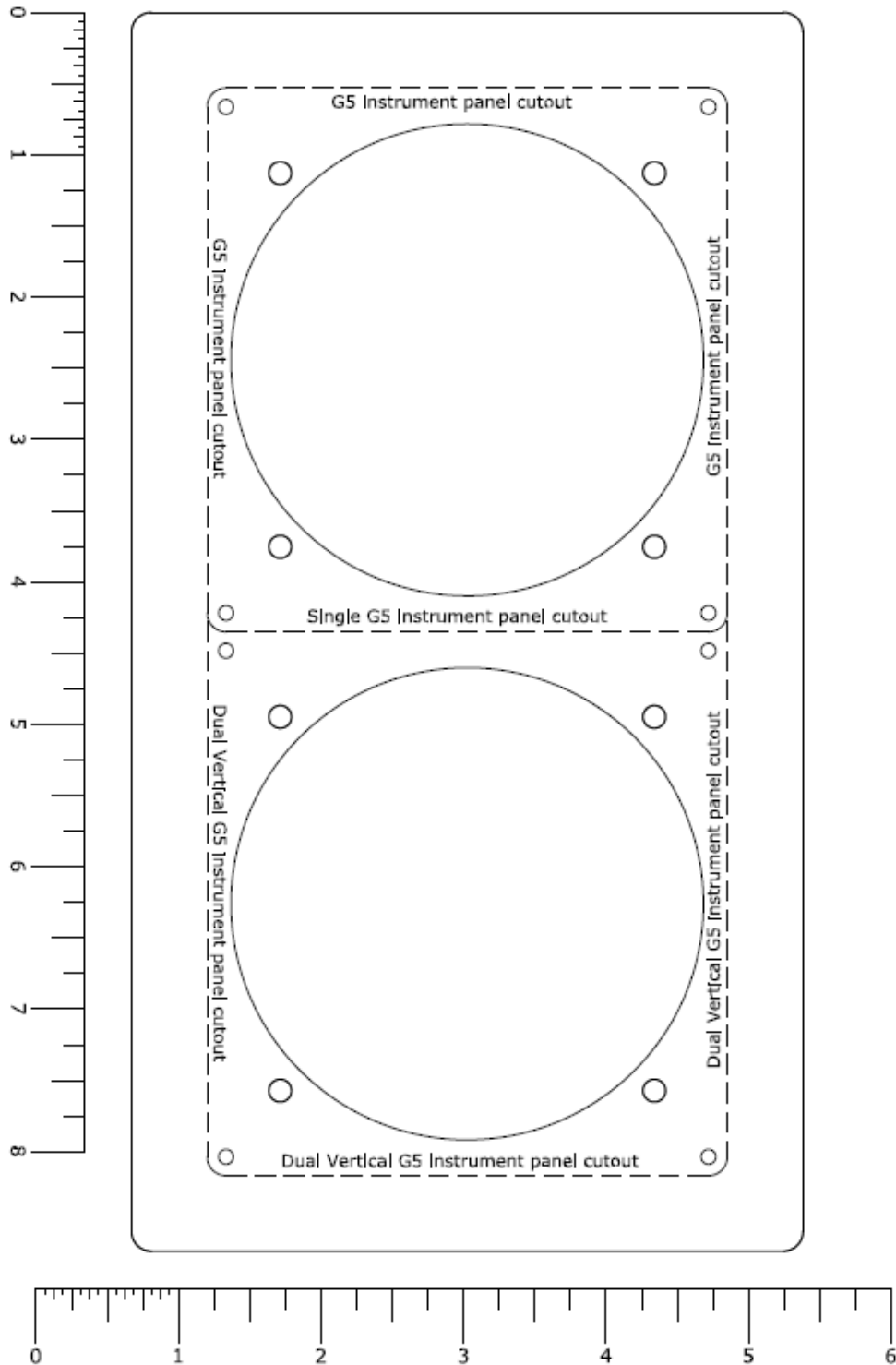
Deburr and finish instrument panel and adapter plate as needed, then install adapter plate per Section 4.1.2.6.1 or 4.1.2.6.2.



**Figure 4-35 Dual Vertical G5 Units Installed**

Install G5 units per Section 4.1.2.2.

*This area intentionally blank*



**Figure 4-36 G5 Flush Mount Adapter Plate Printable Template**

The figure above may be photocopied and scaled as needed to match the full size part. This paper copy may be used along with the instructions on Section 4.1.2.6.5 to verify the proposed installation of the G5 units will meet the installation requirements.



### 4.1.3 GMU 11 Magnetometer Mounting Requirements

The GMU 11 is an extremely sensitive magnetic sensor, more sensitive to magnetic disturbances than a flux gate magnetometer. For this reason, when choosing a location, distance from possible magnetic disturbances is critical to a successful installation.

Consider the following items when choosing a mounting location:

- Maintain as much distance as possible from electric motors, ferromagnetic materials, electrical devices drawing more than 100 mA and electrical conductors
- Ensure that any electrical conductor near the GMU 11 is shielded
- The GMU 11 must not be mounted on an access panel
- Mounting of the GMU 11 in the wing is preferred. Some aircraft cannot mount the GMU 11 in the wing, reference 0 for a consolidated list of aircraft with this restriction.



#### **CAUTION**

*After a location has been selected and a GMU 11 mounting method chosen, a location survey must be performed at that location prior to fabricating or assembling any parts for the GMU 11 mounting. It is possible that the location will fail the survey and the installation will require a new location, with different installation requirements. See Section 4.1.3.1 for Magnetic Interference Survey instructions.*



#### **CAUTION**

*Failure to meet these specifications may result in a failed magnetometer calibration.*

For the installation of the GMU 11 level the aircraft in both the longitudinal and lateral axes. Refer to the aircraft's maintenance manual for leveling instructions. It is preferred that the aircraft is placed on jacks while leveled to avoid inadvertently placing the aircraft in a non-level position when entering, exiting or working the aircraft.

The GMU 11 should be mounted to a surface known to have sufficient structural integrity to withstand additional inertial forces imposed by the 0.26-pound unit.

In order to satisfy the structural mounting requirements for the GMU 11, the following conditions must be met:

- 1) The mounting location must satisfy the alignment requirements shown in Figure 4-37 and Figure 4-38
- 2) The mounting structure, existing or new, must be electrically bonded to the airframe per Section 4.5.
- 3) Any supporting structure must be rigidly connected to the aircraft primary structure through strong structural members capable of supporting substantial loads.
- 4) Mounting platform shall not span greater than 12" in width or length without direct attachment to primary structure. If mounting platform does span greater than 12", add necessary stringers, doublers, bulkhead flange reinforcements, etc., to provide adequate support. Existing honeycomb core sandwich panels with aluminum face sheets are adequate and do not require additional reinforcement.
- 5) A minimum of 3" between the connector end of the GMU 11 and any object must be maintained to ensure clearance for connector and wire harness.
- 6) If a support bracket or shelf needs to be fabricated, it should be fabricated and attached to the aircraft structure in accordance with the methods outlined in AC43.13-2B Chapter 1 and 2, AC43.13-1B Chapter 4, and the following requirements:
  - a) Material shall be 2024-T3 aluminum alloy sheet per AMS-QQ-A-250/4 or Clad 2024-T3 aluminum alloy sheet per AMS-QQ-A-250/5.
  - b) Material shall be minimum 0.032 inch thick.
  - c) Material shall have some type of corrosion protection (primer, alodine, etc.)

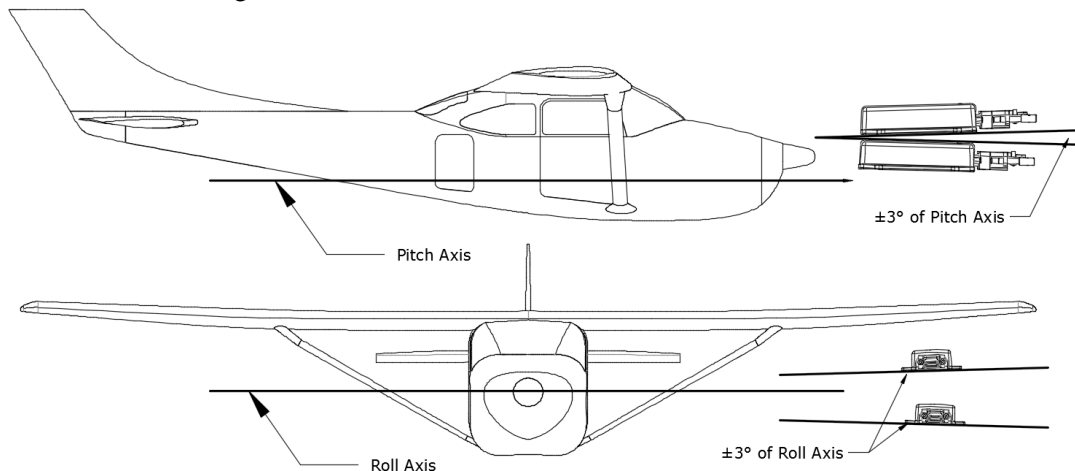
- d) It shall be attached to primary aircraft structure with a minimum of 4 non-magnetic fasteners or rivets from Table 4-1.

**Table 4-1 GMU 11 Supporting Hardware**

| Hardware       | Minimum Specifications                          |
|----------------|-------------------------------------------------|
| <b>Rivets</b>  | MS20470AD3-X (3/32 Diameter, Length A/R)        |
| <b>Screws</b>  | MS51957-XX (#6-32, Stainless Steel, Length A/R) |
| <b>Washers</b> | NAS1149CN632R (#6-32, Stainless Steel)          |
| <b>Nuts</b>    | MS21044C06 (#6-32, Stainless Steel)             |

In general, wing mounting of the GMU 11 magnetometer is preferred. Fuselage mounting is permitted, but NOT within two feet of the cabin area because of numerous potential disturbances that can interfere with accurate operation. The GMU 11 must be mounted in a serviceable location in the aircraft (e.g., accessible through an access panel).

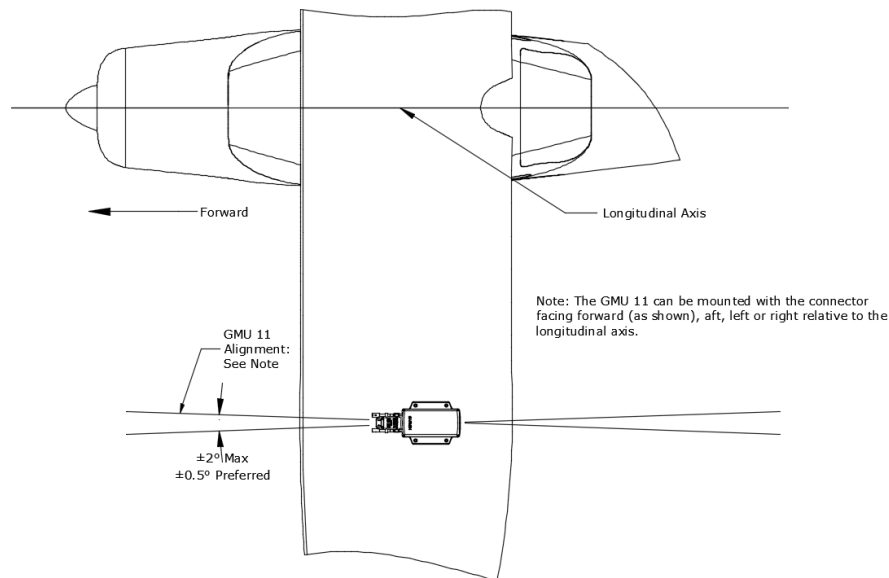
The GMU 11 must be oriented with the mounting flanges facing down to within 3.0° of the aircraft pitch and roll axis as show in Figure 4-37.



**Figure 4-37 GMU 11 Pitch and Roll Requirements**

*This area intentionally blank*

Lateral orientation can be such that the connector faces forward, aft, left or right, but must be within 2° of the longitudinal axis of the aircraft, see Figure 4-38.



**Figure 4-38 GMU 11 Heading Alignment Requirements**

### 4.1.3.1 Magnetic Interference Survey

1. Temporarily place the GMU 11 in the proposed mounting location maintaining orientation as described in Figure 4-37 and Figure 4-38.
2. Secure in place using tape if needed. Do not use clamps or other devices that are ferrous or magnetic.
3. Run the magnetic interference survey in accordance with APPENDIX C. If the survey passes, the location is considered reliable for the installation of the GMU 11.

If the test fails, the location should be considered unreliable until the source of the magnetic interference is identified, remedied and the location is retested and passes the test. If the magnetic interference cannot be remedied, another location should be chosen and tested.

*This area intentionally blank*

## 4.1.3.2 GMU 11 Mounting



### CAUTION

Care should be taken when tightening the mounting screws of the GMU 11. Excessive tightening may damage the mounting flange or break the screws. Fasteners should be tightened until snug, plus one-quarter turn.

GMU should not be mounted in a composite wing.

It may be mounted in a wing constructed of metal so long as any hardware used to attach the GMU or its bracket do not penetrate the fuel tank. For installation in a composite wing tip, of a metal wing, see APPENDIX D.

Use the hardware called out in Figure 4-39 to mount the GMU 11.

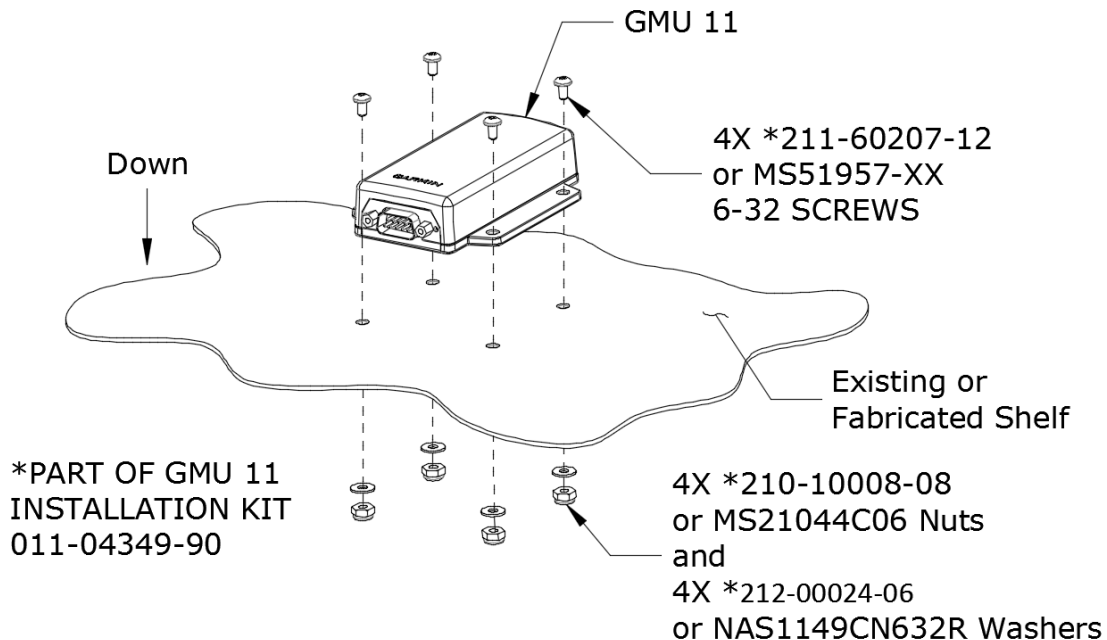


Figure 4-39 GMU 11 Mounting Hardware

*This area intentionally blank*

#### 4.1.4 GAD 29/29B/29D and GAD 13 Mounting Requirements

The GAD 29/29B/29D should be mounted to a surface known to have sufficient structural integrity to withstand additional inertial forces imposed by the 0.63-pound unit. The GAD 13 should be mounted to a surface known to have sufficient structural integrity to withstand additional inertial forces imposed by the 0.24-pound unit.

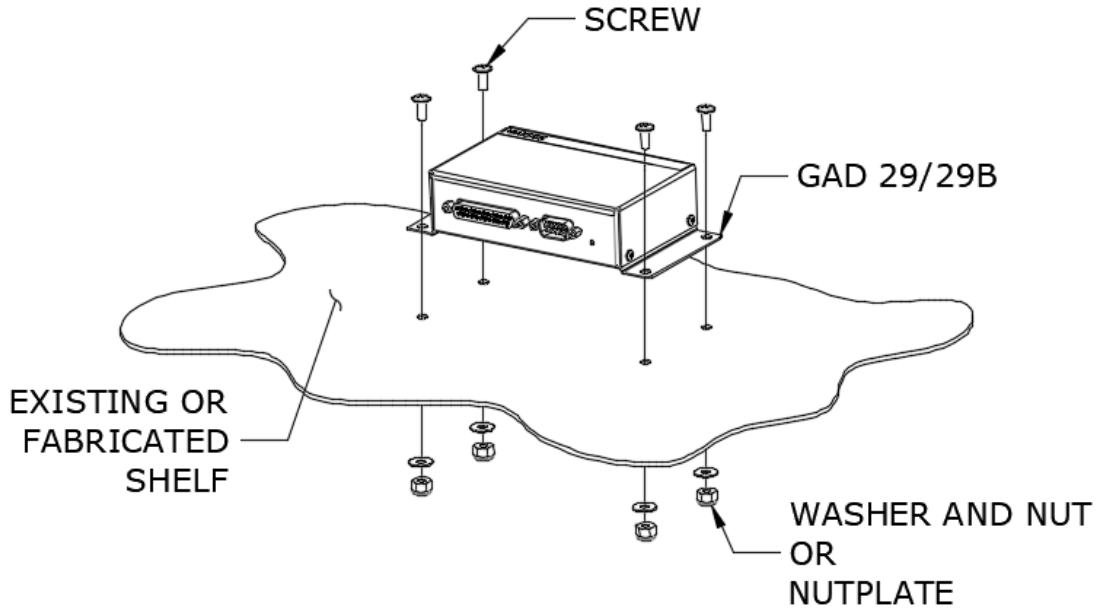
In order to satisfy the structural mounting requirements for the GAD 29/29B/29D and GAD 13, the following conditions must be met:

- 1) The mounting structure, existing or new, must be electrically bonded to the airframe per Section 4.5.
- 2) Any supporting structure must be rigidly connected to the aircraft primary structure through strong structural members capable of supporting substantial loads.
- 3) Mounting platform shall not span greater than 12" in width or length without direct attachment to primary structure. If mounting platform does span greater than 12", add necessary stringers, doublers, bulkhead flange reinforcements, etc., to provide adequate support. Existing honeycomb core sandwich panels with aluminum face sheets are adequate and do not require additional reinforcement.
- 4) A minimum of 3" between the GAD 29/29B/29D and GAD 13 connector end and any object must be maintained to ensure clearance for connectors and wire harness.
- 5) If a support bracket or shelf needs to be fabricated, it should be fabricated and attached to the aircraft structure in accordance with the methods outlined in AC43.13-2B Chapter 1 and 2, AC43.13-1B Chapter 4, and the following requirements:
  - a) Material shall be 2024-T3 aluminum alloy sheet per AMS-QQ-A-250/4 or Clad 2024-T3 aluminum alloy sheet per AMS-QQ-A-250/5.
  - b) For the GAD 29/29B/29D, material shall be minimum 0.040 inch thick. For the GAD 13, material shall be minimum 0.032 inch thick.
  - c) Material shall have some type of corrosion protection (primer, alodine, etc.)
  - d) It shall be attached to primary aircraft structure with a minimum of 4 fasteners or rivets listed in Table 4-2.

**Table 4-2 GAD 29/29B/29D, GAD 13 Supporting Hardware**

| <b>Hardware</b> | <b>Minimum Specifications</b>            |
|-----------------|------------------------------------------|
| <b>Rivets</b>   | MS20470AD3-X (3/32 Diameter, Length A/R) |
| <b>Screws</b>   | MS35206-XXX (#6-32, Length A/R)          |
| <b>Washers</b>  | NAS1149FN632P                            |
| <b>Nuts</b>     | MS21042L06                               |

Using the hardware called out in Figure 4-40 and Figure 4-41, mount the GAD 29/29B/29D and GAD 13, respectively, to the chosen mounting location. Recommended torque of fasteners is 20-25 in-lbs.

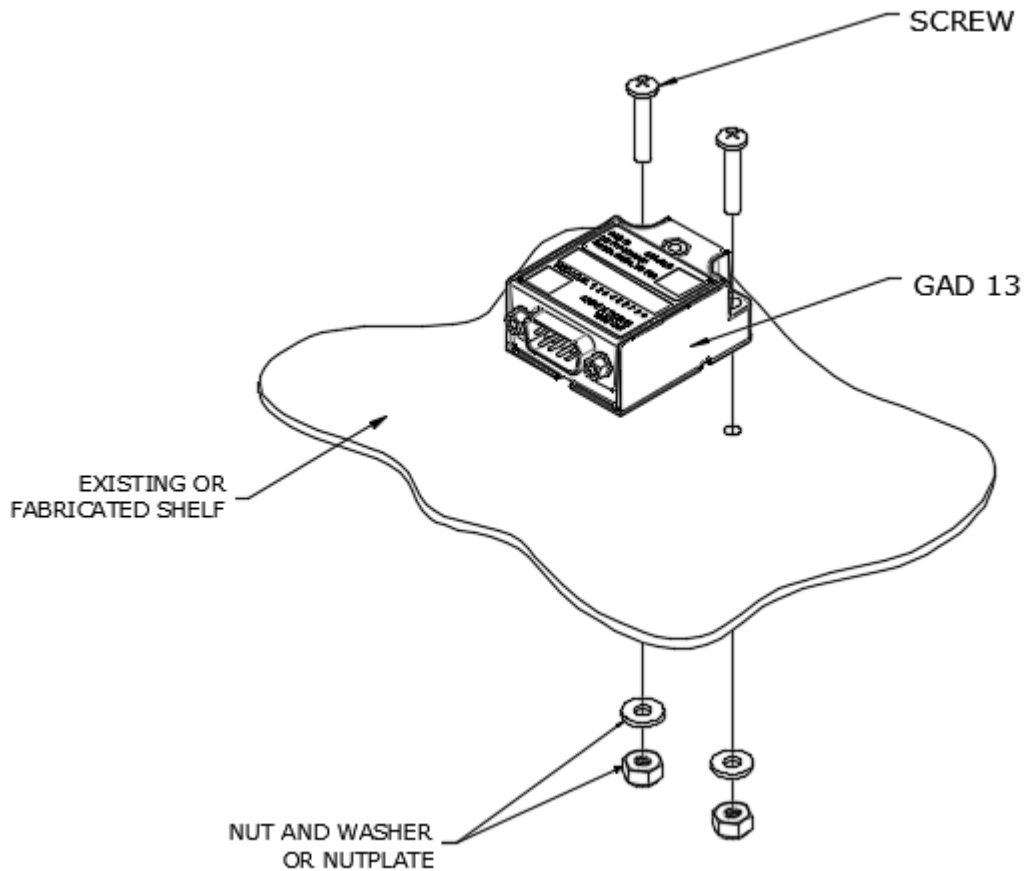


|                |                                                |    |                     |                                              |
|----------------|------------------------------------------------|----|---------------------|----------------------------------------------|
| <b>Screws</b>  | MS35206-XXX OR AN525832RXX<br>(#8, Length A/R) |    |                     |                                              |
| <b>Washers</b> | NAS1149FN8XXP                                  | OR | <b>#8 Nutplates</b> | Standard Part; Any MS (Mil-Spec) Part Number |
| <b>Nuts</b>    | MS21044N08                                     |    | <b>Rivets</b>       |                                              |

|                           |                |
|---------------------------|----------------|
| <b>Countersunk Screws</b> | #8 MS24693-XXX |
| <b>Washers</b>            | NAS1149FN832P  |
| <b>Nuts</b>               | MS21044N08     |

**Figure 4-40 GAD 29/29B/29D Mounting Hardware**

*This area intentionally blank*



|                |                              |    |                     |                                              |
|----------------|------------------------------|----|---------------------|----------------------------------------------|
| <b>Screws</b>  | MS35206-XXX (#6, Length A/R) |    |                     |                                              |
| <b>Washers</b> | NAS1149FN632P                | OR | <b>#6 Nutplates</b> | Standard Part; Any MS (Mil-Spec) Part Number |
| <b>Nuts</b>    | MS21044N06                   |    | <b>Rivets</b>       | MS20426AD3-X                                 |

|                           |                |
|---------------------------|----------------|
| <b>Countersunk Screws</b> | #6 MS24693-XXX |
| <b>Washers</b>            | NAS1149FN632P  |
| <b>Nuts</b>               | MS21044N06     |

**Figure 4-41 GAD 13 Mounting Hardware**

#### 4.1.4.1 GAD 29B Transformer Mounting Instructions

Reference Section 3.4.10 for GAD 29B transformer mounting.

#### 4.1.5 Pneumatic Connections

The G5 Attitude indicator and G5 DG/HSI use pitot and static pressure for the secondary display of altitude and airspeed. The installer must install the necessary hoses and fittings to interface to the existing aircraft pitot and static pressure source. Below are guidelines to use for this installation.

The G5 has two ports that are connected to the aircraft's pitot and static pressure sources. The ports are



labeled on the unit using the abbreviations “P” and “S” respectively (Figure 6-13). The pressure ports have 1/8-27 ANPT female threads. The mating fitting must have 1/8-27 ANPT male threads.

Determine the hose/connection material that best interfaces with the existing aircraft installation. Reference the appropriate aircraft parts manual to determine the current part numbers associated with the aircraft installation of hose and connections used in the pitot/static system.

Use appropriate tubing and fittings to connect the pitot and static lines to the unit. Avoid sharp bends in the tubing and route hoses clear of aircraft control cables. The G5 must not be at the low point of the pneumatic plumbing lines to avoid moisture or debris collecting at or near the unit. Ensure that no deformations of the airframe surface have been made that would affect the relationship between static air pressure and true ambient static air pressure for any flight condition. Refer to 14 CFR Part 43, Appendix E and AC43.13-1B, Chapter 12, Section 4 for approved practices while installing hoses and connections. If this static source had an alternate static source selector switch, it must be retained.

For aircraft equipped with a single pitot-static system, the G5 must be connected to the pitot-static system used by the pilot's instruments. For aircraft equipped with a dual pitot-static system, the G5 must be connected to the pitot-static system that is independent from the pilot's instruments.



**CAUTION**

*To avoid damaging the G5 pressure sensors, both the pitot and static ports must be connected to the test set.*



**CAUTION**

*Verify sealant/tape is not present inside the plumbing upon assembly. Use care to avoid getting fluids or particles inside the pneumatic lines or G5 ports.*

*This area intentionally blank*



## 4.1.6 Glare Shield Mounted GPS Antenna Mounting Requirements

The GPS antenna (P/N 011-04036-00/10) is designed for installation on top of an existing instrument panel glareshield. The selected location must offer good visibility of the sky through the windshield. Installation of the GPS antenna cannot obstruct or limit the pilot's vision (even though the antenna has a low profile). The optimal antenna position is horizontal, or as close to horizontal as practical given the shape of the glareshield.

Fastener holes for screw-mounted antenna installation, as depicted in Figure 4-43, must not penetrate through the ventilation or defrost channels built into the glareshield, if present. If the glareshield is part of the instrument panel structure, fastener holes may only be drilled if provisioned by the aircraft maintenance manual or structural repair manual.

A TNC/BNC Adaptor (P/N 330-01754-00) is required to connect the GPS antenna P/N 011-04036-00 to the G5. The GPS antenna P/N 011-04036-10 does not require the TNC/BNC adaptor.

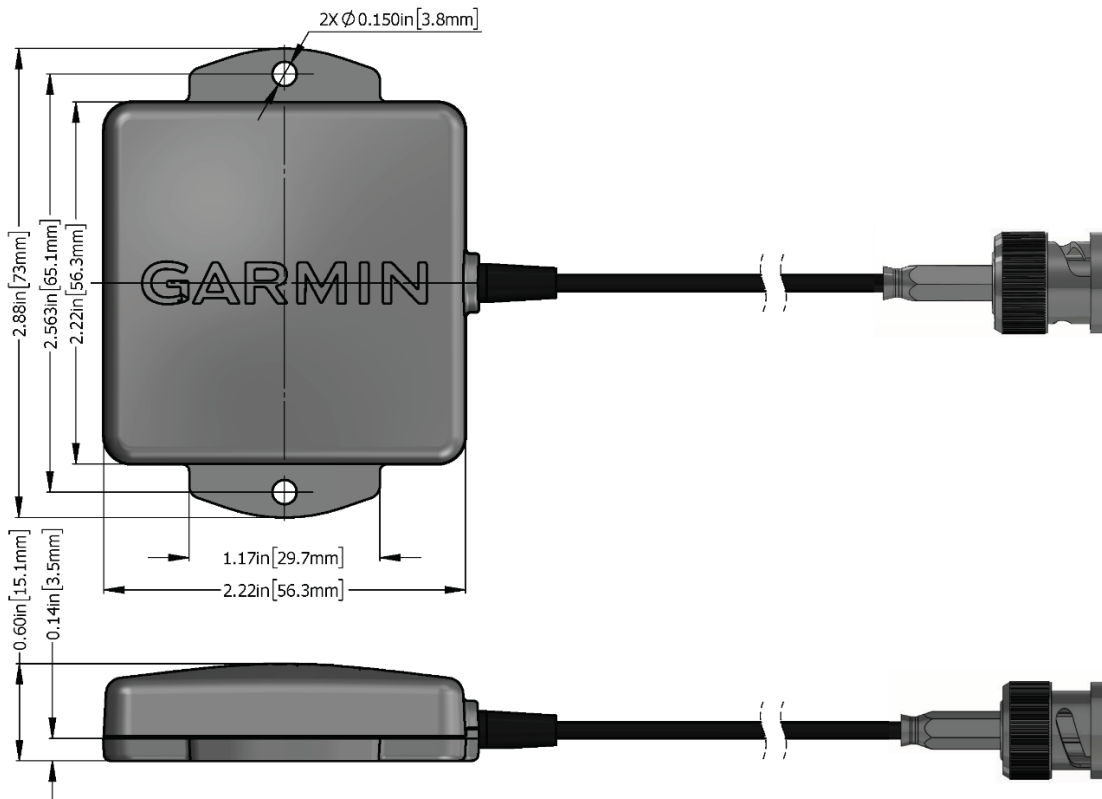
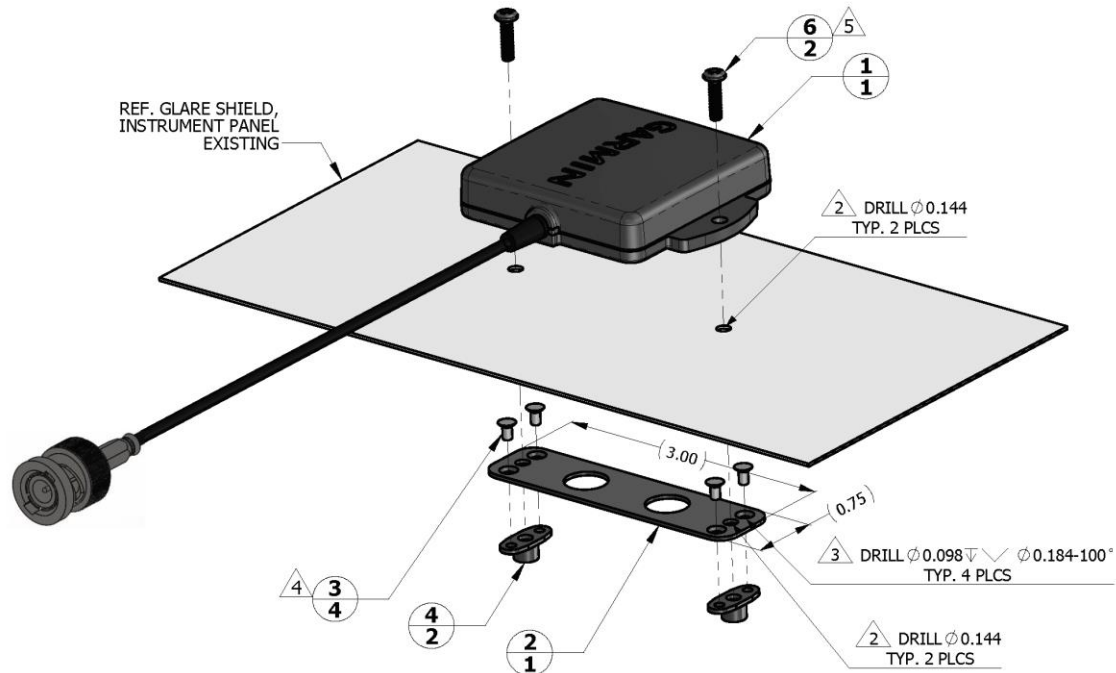


Figure 4-42 Glare Shield Mounted GPS Antenna Dimensions (011-04036-10 shown)

*This area intentionally blank*

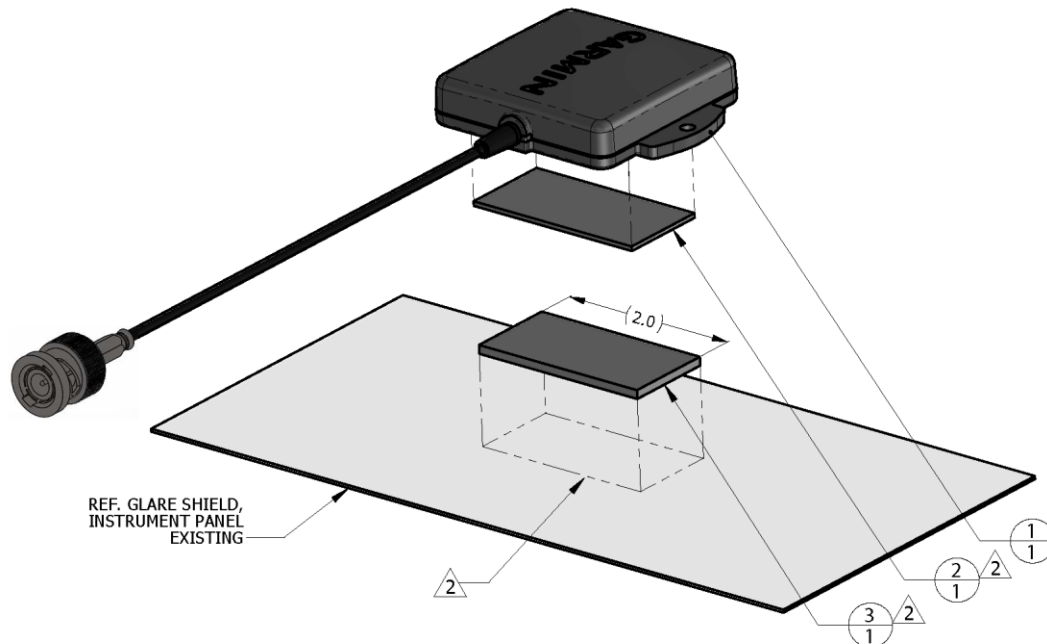


| 2   | 6    | MS35206-229  | SCREW, MACHINE, PAN HEAD, CROSS RECESSED, CAD PLATED .1380- 32 UNC-2A, 0.438 IN LONG         |
|-----|------|--------------|----------------------------------------------------------------------------------------------|
|     |      | MS35214-26   | SCREW, MACHINE, PAN-HEAD, CROSS RECESSED, BLACK OXIDE FINISH .1380- 32 UNC-2A, 0.438 IN LONG |
| 2   | 4    | MS21069L06   | NUT, SELF-LOCKING, PLATE, TWO-LUG, REDUCED RIVET SPACING, LOW HEIGHT, STEEL .138-32 UNJC-3B  |
| 4   | 3    | MS20426AD3-3 | RIVET, SOLID, COUNTERSUNK 100 DEG, PRECISION HEAD, 3/32 IN OD, 3/16 IN LONG                  |
| 1   | 2    | PLATE DETAIL | SHEET, 6061-T6 AL, 0.040 INCH THICK PER AMS 4025, AMS 4027, AMS-QQ-A-250/11                  |
| 1   | 1    | 011-04036-10 | BACKUP GPS ANTENNA                                                                           |
| QTY | ITEM | PART NUMBER  | DESCRIPTION                                                                                  |

## NOTES

1. DIMENSIONS ARE IN INCHES UNLESS OTHERWISE SPECIFIED.
2. FASTENER HOLES ARE LOCATED TO MATCH BACKUP GPS ANTENNA ITEM 1.
3. FASTENER HOLES ARE LOCATED TO MATCH NUTPLATE ITEM 4.
4. RIVETS ARE INSTALLED PER MIL-R-47196 (NASM47196) RIVET, BUCK TYPE, *PREPARATION FOR AND INSTALLATION*, OR PER MIL-STD-403 *PREPARATION FOR AND INSTALLATION OF RIVETS AND SCREWS, ROCKET MISSILE, AND AIRFRAME STRUCTURES*.
5. USE FASTENER WITH BLACK OXIDE FINISH IF ANTENNA LOCATION IS SUCH THAT FASTENERS ARE VISIBLE TO THE PILOT OR COPILOT AND MIGHT BECOME A SOURCE OF ACCIDENTAL GLARE. TORQUE .1380-32 UNC-2A SCREWS HAND TIGHT.

**Figure 4-43 Glare Shield Mounted GPS Antenna (Screw-mounted Installation Example)**



| QTY | ITEM | PART NUMBER  | DESCRIPTION                                                                                |
|-----|------|--------------|--------------------------------------------------------------------------------------------|
| 1   | 3    | A-A-55126    | FASTENER TAPE, SYNTHETIC, ADHESIVE BACKED, A-A-55126 CLASS 1/2, TYPE 1, LOOP 1.0 INCH WIDE |
| 1   | 1    | 011-04036-10 | BACKUP GPS ANTENNA                                                                         |

#### NOTES

1. DIMENSIONS ARE IN INCHES UNLESS OTHERWISE SPECIFIED.
2. PEEL OFF ADHESIVE PROTECTING FILM AND PRESS THE FASTENER TAPE IN TO BOND. SURFACES MUST BE CLEAN AND FREE FROM OIL OR OTHER CONTAMINANTS. LOOP FASTENER IS BONDED TO GLARE SHIELD AND HOOK FASTENER IS BONDED TO ANTENNA. TAPE FASTENER MUST BE 2.0 INCHES OR LONGER.
3. GPS ANTENNA KIT, GARMIN PART NO. 010-12444-00 INCLUDES DUAL LOCK FASTENER, GARMIN PART NO. 252-00433-00 WHICH CAN BE USED INSTEAD OF A-A-55126 FASTENER TAPE.

**Figure 4-44 Glare Shield Mounted GPS Antenna (Hook & Loop Installation Example, BNC similar)**

### 4.1.7 GTP 59 Mounting

An effective location for the GTP 59 OAT Probe is on or near an access panel on the bottom of the wing, or in areas where it would mostly be shaded in straight and level flight. A typical installation example is shown in Figure 4-46.

The GTP 59 probe has no icing protection. Temperature measurements may be incorrect if ice accumulates on the probe, which in turn may affect computations of true airspeed, delta-ISA, or other data that depends on the measurement of air temperature.

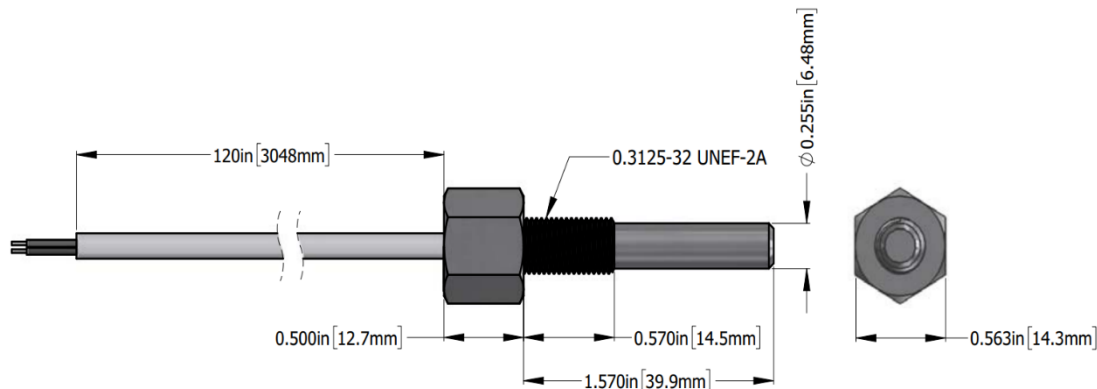
The GTP 59 cannot be mounted on or near a control surface. Control surfaces include but are not limited to ailerons, elevators, rudder, trim tabs and speed brakes.

#### **GTP 59 Probe Installation in Metal and Tube-and-Fabric Aircraft**

For metal and tube-and-fabric aircraft, the electrical bond between GTP 59 and nearby aircraft metallic structure (tubular structure in the case of tube and fabric aircraft) must achieve a direct current (DC) resistance less than or equal to 2.5 mΩ with the remote end connector disconnected. The GTP 59 can only be installed in lightning zones 2A or 3, per APPENDIX F.

For tube and fabric aircraft it may be necessary to use a bonding strap from the doubler plate shown in Figure 4-46 to the tubular structure to electrically bond the probe. See AC43.13-1B or later for electrical bonding to tubular structure. The bonding strap must:

1. Have the cross-sectional area greater than 0.016 square inches (approx. 20,800 circular mils). QQB575R30T437 7/16" tubular braid (24,120 circular mils) or QQB575F36T781 3/4" flat braid (20,800 circular mils) meet this requirement.
2. Be as short as possible, not to exceed 6 inches. When installed, the strap must not loop back on itself.
3. Use MS20659-130 lug and #10 stud (or larger) attached to local aircraft metallic structure with minimum thickness of 0.032 inches.
4. Use a 5/16 stud size terminal lug connected directly to GTP 59 probe.



**Figure 4-45 GTP 59 OAT Probe Dimensions**

For metal, and tube-and-fabric aircraft, if the GTP 59 is installed in an access panel in Lightning Zone 2A, the access panel must be at least 0.032-inch thick aluminum or, if the access panel is less than 0.032-inch thick aluminum, a doubler that is at least 0.032-inch thick aluminum (per Figure 4-46) must be installed.

### **GTP 59 Probe Installation in Metallic Airframes**

For aircraft with metallic airframes, a doubler is required when the GTP 59 probe is installed in the skin. The doubler must be a minimum of 2 inches in diameter, with a minimum thickness of 0.032 inches and at least one gauge thicker than the skin. The doubler material and installation must be provisioned by the aircraft structural repair manual or standard practices manual, or alternatively:

1. Use the same material as the aircraft skin. If the material used in the construction of the aircraft skin is not known, 2024-T3 aluminum per AMS-QQ-A-250/5 can be used.
2. If corrosion protection methods are not specified by the model-specific aircraft standard practices manual, the doubler material must be chemical conversion coated per MIL-DTL-5541 Type II or MIL-DTL-81706 Type II and primed with a high-solids chemical and solvent resistant epoxy primer per MIL-PRF-23377, Class N.

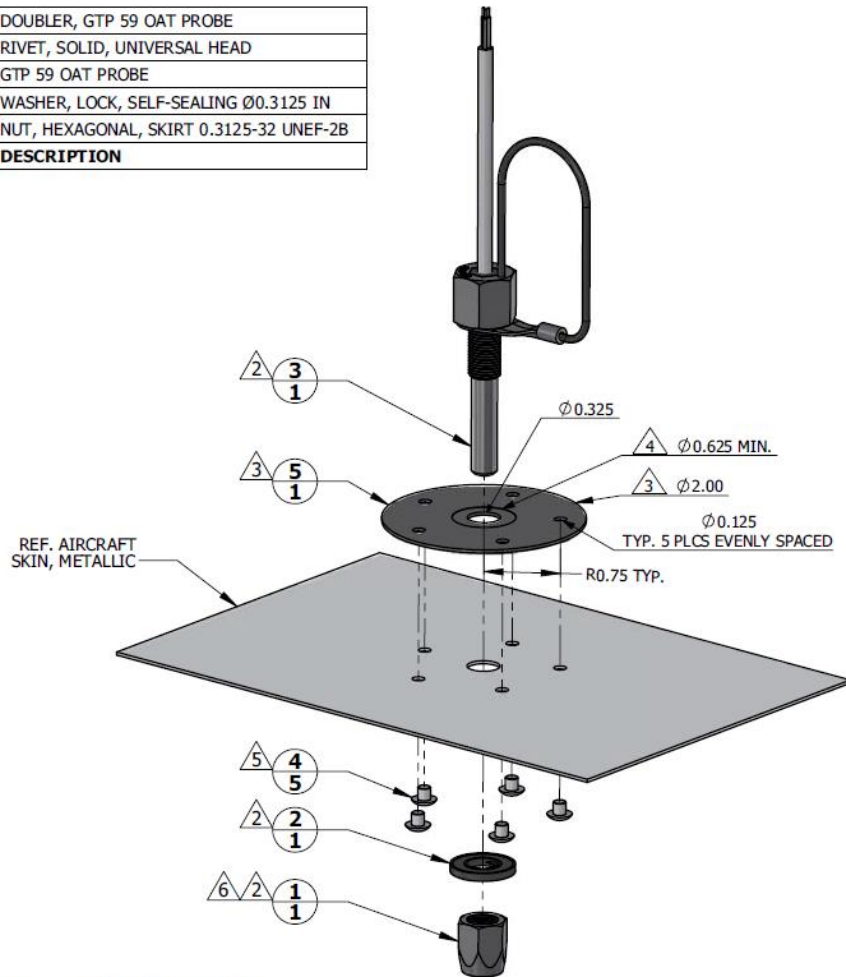


### **CAUTION**

*The GTP 59 probe must not be mounted in a fuel tank area (wet or dry). An air scoop or ducted inlet is an adequate location for the GTP 59 probe. The probe must be located no closer to the inlet edge than the width of its narrowest opening.*

It is recommended the GTP 59 probe is installed in Lightning Zone 3, although Zone 2A may be an acceptable location for certain aircraft, refer to APPENDIX E.

| 1    | 5    |              | DOUBLER, GTP 59 OAT PROBE               |
|------|------|--------------|-----------------------------------------|
| 5    | 4    | MS20470AD4-2 | RIVET, SOLID, UNIVERSAL HEAD            |
| 1    | 3    | 494-00022-00 | GTP 59 OAT PROBE                        |
| 1    | 2    | 212-00026-00 | WASHER, LOCK, SELF-SEALING Ø0.3125 IN   |
| 1    | 1    | 210-00055-00 | NUT, HEXAGONAL, SKIRT 0.3125-32 UNEF-2B |
| QTY. | ITEM | PART NUMBER  | DESCRIPTION                             |



#### NOTES

1. DIMENSIONS ARE IN INCHES UNLESS OTHERWISE SPECIFIED.
2. NUT ITEM 1, WASHER ITEM 2, AND PROBE ITEM 3 ARE PART OF GTP 59 OAT PROBE ASSEMBLY (KIT), GARMIN P/N 011-00978-00.
3. MINIMUM DOUBLER SIZE SHOWN. CIRCULAR SHAPE OPTIONAL. DOUBLER THICKNESS IS ONE GAUGE THICKER THAN AIRCRAFT SKIN.
4. SPOT FACE TO REMOVE COATING AS REQUIRED TO MAINTAIN ELECTRICAL BOND.
5. RIVETS ARE INSTALLED PER MIL-R-47196 (NASM47196) RIVET, BUCK TYPE, *PREPARATION FOR AND INSTALLATION*, OR PER MIL-STD-403 *PREPARATION FOR AND INSTALLATION OF RIVETS AND SCREWS, ROCKET MISSILE, AND AIRFRAME STRUCTURES*.
6. TORQUE .3125-32 UNEF-2B NUT 100.0 ±20.0 LBF-IN.

**Figure 4-46 GTP 59 Mounting (Aircraft with Metallic Skin Example)**

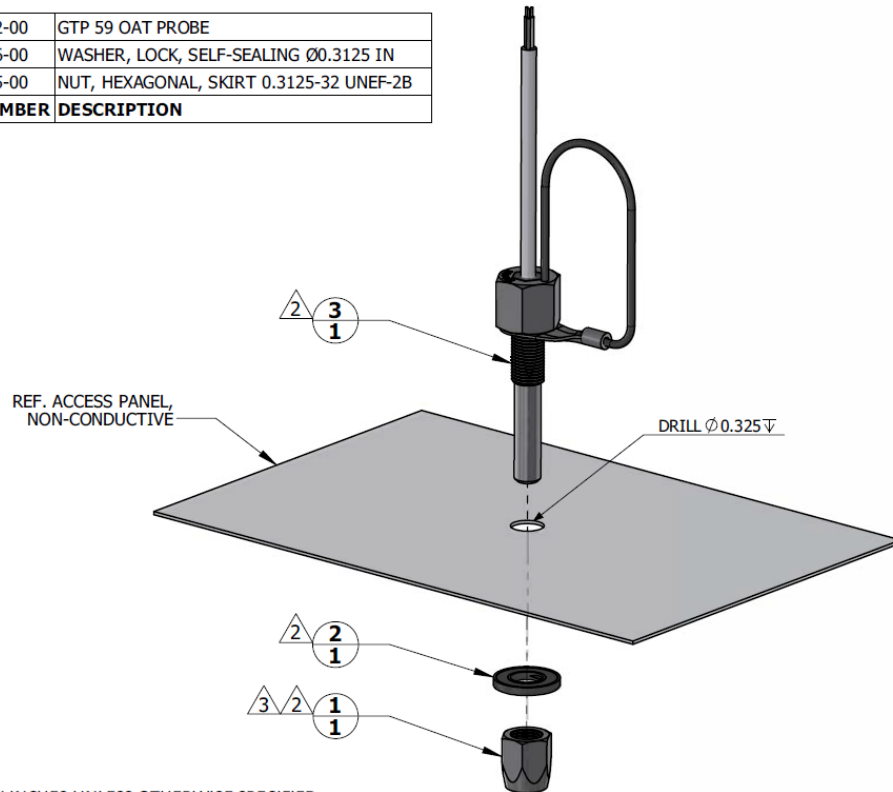
#### **GTP 59 Probe Installation in Composite Aircraft**

For composite aircraft, the GTP 59 probe cannot be mounted on the fuselage and must be mounted on an access panel or inspection cover, in a zone 3 area of the aircraft per APPENDIX F. If the access panel or inspection cover is conductive, a non-conductive doubler must be used and a minimum 0.5 inches of clearance maintained between the GTP 59 probe/terminal lug and any conductive element of aircraft structure. Typical installation examples are shown in Figure 4-47 and Figure 4-48.

For composite aircraft, the GTP 59 probe must be installed in Lightning Zone 3 and installed such that it is electrically isolated. For aircraft model-specific information regarding acceptable lightning zones for the GTP 59, refer to APPENDIX E. Refer to APPENDIX F for lightning zone details.

Regardless of location, the probe must protrude into the air flow when the aircraft is in flight and be kept away from direct sources of heat (e.g., engine exhaust, direct sunlight, cabin exhaust, etc.) to provide an accurate air temperature measurement.

|             |             |                    |                                         |
|-------------|-------------|--------------------|-----------------------------------------|
| 1           | 3           | 494-00022-00       | GTP 59 OAT PROBE                        |
| 1           | 2           | 212-00026-00       | WASHER, LOCK, SELF-SEALING Ø0.3125 IN   |
| 1           | 1           | 210-00055-00       | NUT, HEXAGONAL, SKIRT 0.3125-32 UNEF-2B |
| <b>QTY.</b> | <b>ITEM</b> | <b>PART NUMBER</b> | <b>DESCRIPTION</b>                      |



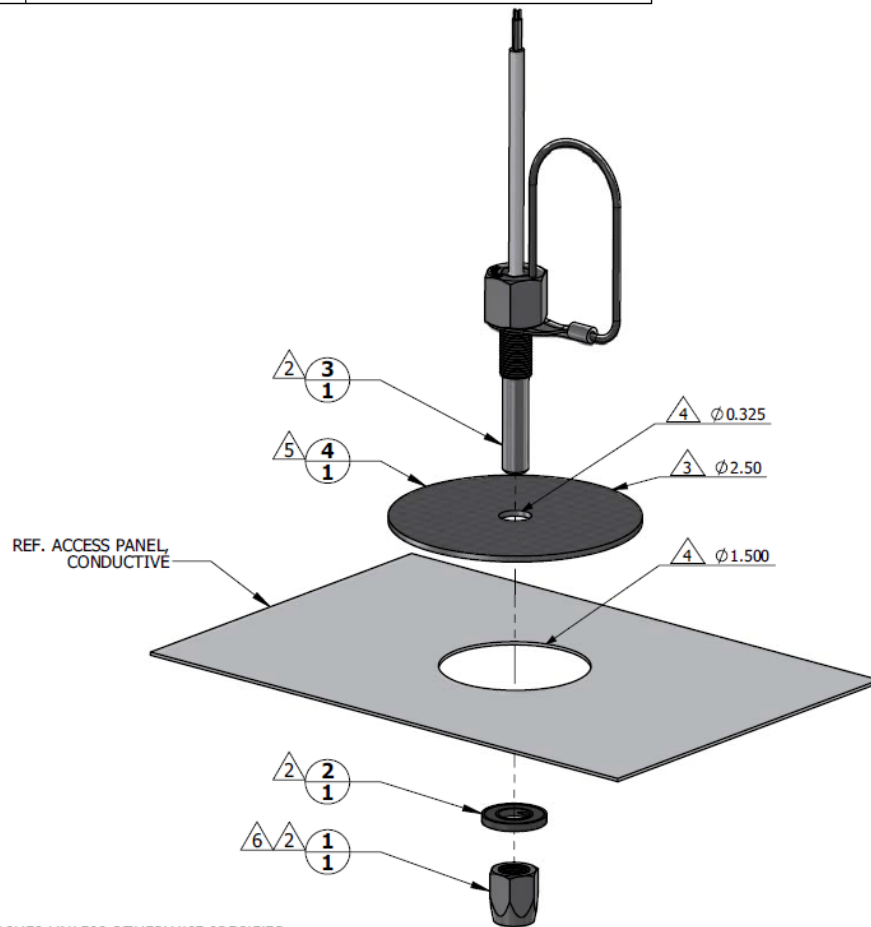
#### NOTES

1. DIMENSIONS ARE IN INCHES UNLESS OTHERWISE SPECIFIED.
2. NUT ITEM 1, WASHER ITEM 2, AND PROBE ITEM 3 ARE PART OF GTP 59 OAT PROBE ASSEMBLY (KIT), GARMIN P/N 011-00978-00.
3. TORQUE .3125-32 UNEF-2B NUT 100.0 ±20.0 LBF-IN.

**Figure 4-47 GTP 59 Mounting - Composite Aircraft (Non-conductive Access Panel)**

*This area intentionally blank*

| 1    | 4    |              | DOUBLER, GTP 59 OAT PROBE, PHENOLIC WITH COTTON FIBRE MIL-I-34768/1-S |
|------|------|--------------|-----------------------------------------------------------------------|
| 1    | 3    | 494-00022-00 | GTP 59 OAT PROBE                                                      |
| 1    | 2    | 212-00026-00 | WASHER, LOCK, SELF-SEALING Ø0.3125 IN                                 |
| 1    | 1    | 210-00055-00 | NUT, HEXAGONAL, SKIRT 0.3125-32 UNEF-2B                               |
| QTY. | ITEM | PART NUMBER  | DESCRIPTION                                                           |



#### NOTES

1. DIMENSIONS ARE IN INCHES UNLESS OTHERWISE SPECIFIED.
2. NUT ITEM 1, WASHER ITEM 2, AND PROBE ITEM 3 ARE PART OF GTP 59 OAT PROBE ASSEMBLY (KIT), GARMIN P/N 011-00978-00.
3. MINIMUM DOUBLER SIZE SHOWN. CIRCULAR SHAPE OPTIONAL. DOUBLER THICKNESS IS 0.060 INCH MINIMUM.
4. DOUBLER IS LOCATED SUCH THAT THE PROBE HOLE IS CENTERED ON THE HOLE IN ACCESS PANEL.
5. BOND DOUBLER TO ACCESS PANEL USING PROCESS AND MATERIALS AS SPECIFIED IN AIRCRAFT MAINTENANCE MANUAL AND/OR STRUCTURAL REPAIR MANUAL FOR NON-STRUCTURAL APPLICATIONS.
6. TORQUE .3125-32 UNEF-2B NUT 100.0 ±20.0 LBF-IN.

**Figure 4-48 GTP 59 Mounting - Composite Aircraft (Conductive Access Panel)**



### 4.1.8 Portable Avionics Interface Connector

The portable interface connector (3P51) can be mounted to the instrument panel or a kick panel located in the cockpit. The restrictions for mounting this connector are:

1. Do not mount connector to yoke
2. Maintain at least a 0.20” distance from the edge of the panel.
3. Cannot be mounted in a plastic interior panel, composite is acceptable
4. Connector must be electrically bonded to airframe, see section 4.5.

Connector can be mounted on a fabricated bracket made of 2024-T3 aluminum alloy sheet per AMS-QQ-A-250/4 or clad 2024-T3 aluminum alloy sheet per AMS-QQ-A-250/5. Minimum sheet thickness of 0.032”.

See section 5 for complete wiring interface.

## 4.2 Electrical Installation

### 4.2.1 Special Tools

Crimp tools and positioners are required to ensure consistent, reliable crimp contact connections for the D-sub connectors. The following crimp tools are recommended:

**Table 4-3: Contact Crimp Tooling**

| Manufacturer | Crimp Tool P/N | Positioner P/N | Insertion/Extraction Tool P/N |
|--------------|----------------|----------------|-------------------------------|
| MIL-Spec     | M22520/2-01    | M22520/2-08    | M81969/1-02                   |
| Daniels      | AFM8           | K13-1          |                               |

### 4.2.2 Power Distribution

The circuit protection device for the G5 and GAD 29/29B/29D must be a push-pull manually resettable circuit breaker or identically rated circuit protection device approved by the aircraft type certificate. See Section 3.2.1 for required circuit breaker part numbers. Use the following guidance for which electrical bus the G5 needs to be connected (Note: some aircraft manufacturers may label the battery bus as “essential bus” or “main bus”):

- G5 needs to be connected to the battery bus when installed:
  - As an Attitude Indicator (ADI), installed in either the turn coordinator or attitude indicator position
- G5 needs to be connected to the avionics bus when installed:
  - As a HSI
  - In the DG position





### 4.2.3 Wiring Harness Assembly

Allow adequate space for installation of the wiring harness and connectors. Construct the wiring harness in accordance with the information contained in this and the following sections. Mark wire in accordance with AC 43.13-1B Chapter 11 Section 16. Strip and insert the wire into the contact and crimp with the recommended (or equivalent) crimping tools. Insert the contacts into the connector as specified by the interconnect diagrams in Section 5. Verify the contacts are properly engaged into the connector by gently tugging on the wire. Mark harness connectors in accordance with AC 43.13 Chapter 11 Section 17. Route and secure the wiring harness away from sources of electrical interference.

The tables below list the parts required to complete the assembly of the G5, GMU 11, GAD 29/29B/29D, and GAD 13 wiring harness connectors. Some of the parts required for this installation are included in the connector kit, and some are to be provided by the installer. See the notes below the tables for parts that are included in the connector kit. The Garmin connector backshell gives the installer the ability to easily terminate shield grounds at the connector backshell as shown in and Figure 4-51. Numbers referenced in Figure 4-49, Figure 4-50, and Figure 4-51 correspond to items listed in Table 4-4, Table 4-5, and Table 4-6.

*This area intentionally blank*



**Table 4-4: G5 (1P51, 2P51), GMU 11 (P111), and GAD 13 (P131) Connector Parts**

| Item | Description                                                                                                                                 | Part Number                           | Notes |
|------|---------------------------------------------------------------------------------------------------------------------------------------------|---------------------------------------|-------|
| 1    | Shield Termination, Solder Style, Insulated, Heat-Shrinkable, Environment Resistant (X = size)                                              | AS83519/1-X<br>(SAE-AS83519)          | 1     |
| 2    | Contact, Socket, MIL Crimp, Size 20                                                                                                         | M39029/63-368, or<br>336-00022-02     | 2, 4  |
| 3    | Insulation Tape, Electrical, Self-Adhering, Unsupported Silicone Rubber                                                                     | A-A-59163<br>(MIL-I-46852C)           |       |
| 4    | Terminal, Lug, Crimp Style, Copper, Insulated, Ring Tongue, Bell Mouthed, Type II, Class I                                                  | MS25036-149                           |       |
| 5    | Connector, Plug, D-Sub, MIL Crimp Socket                                                                                                    | 330-00625-09                          | 2, 4  |
| 6    | Backshell, Jackscrew, 9/15 Pin                                                                                                              | 125-00171-00                          | 2     |
| 7    | Clamp, Backshell, Jackscrew, 9/15 Pin                                                                                                       | 115-01078-00                          | 2, 4  |
| 8    | Screw, 4-40x.375, PHP, SS/P, w/Nylon                                                                                                        | 211-60234-10                          | 2, 4  |
| 9    | Cover, Backshell, Jackscrew, 9/15 Pin                                                                                                       | 115-01079-00                          | 2, 4  |
| 10   | Screw, 4-40x.187, FLHP100, SS/P, w/Nylon                                                                                                    | 211-63234-06                          | 2, 4  |
| 11   | Screw, PHP, 8-32 x 0.312", Cad-Plated Steel, or<br>Screw, PHP, 8-32 x 0.312", Stainless                                                     | MS35206-242, or<br>MS51957-42         |       |
| 12   | Split Washer, #8 (0.045" compressed thickness), Cad-plated Steel, or<br>Split Washer, #8 (0.045" compressed thickness), Stainless           | MS35338-42, or<br>MS35338-137         |       |
| 13   | Flat washer, Cad-plated Steel, #8, 0.032" thick, 0.174" ID, 0.375" OD, or<br>Flat Washer, Stainless, #8, 0.032" thick, 0.174" ID, 0.375" OD | NAS1149FN832P,<br>or<br>NAS1149CN832R |       |
| 14   | Flat Braid, 1/16"                                                                                                                           | AA59569F36T0062                       | 1     |
| 15   | Lightning Protection Module assembly                                                                                                        | 011-05224-00                          | 3     |

Notes:

- AS83519/1-X and braid are the preferred method for shield termination. Alternately, AS83519/2-X with pre-installed shield drain may be used.
- Garmin Part Number. Included in kit P/N 011-03002-10.
- Garmin Part number. Included in kit P/N 011-03002-20. This is installed on the G5 connectors 1P51, 2P51. The GAD29/29B/29D, GMU11, and GAD13 do not require this assembly.
- Garmin Part Number. Included in kit P/N 011-03002-20.

*This area intentionally blank*



**Table 4-5: GAD 29/29B/29D 9-pin (P291) Connector Parts**

| Item | Description                                                                                                                                 | Part Number                           | Notes |
|------|---------------------------------------------------------------------------------------------------------------------------------------------|---------------------------------------|-------|
| 1    | Shield Termination, Solder Style, Insulated, Heat-Shrinkable, Environment Resistant (X = size)                                              | AS83519/1-X<br>(SAE-AS83519)          | 1     |
| 2    | Contact, Socket, MIL Crimp, Size 20                                                                                                         | M39029/63-368, or<br>336-00022-02     | 2     |
| 3    | Insulation Tape, Electrical, Self-Adhering, Unsupported Silicone Rubber                                                                     | A-A-59163<br>(MIL-I-46852C)           |       |
| 4    | Terminal, Lug, Crimp Style, Copper, Insulated, Ring Tongue, Bell Mouthed, Type II, Class I                                                  | MS25036-149                           |       |
| 5    | Connector, Plug, D-Sub, MIL Crimp Socket                                                                                                    | 330-00625-09                          | 2     |
| 6    | Backshell, Jackscrew, 9/15 Pin                                                                                                              | 125-00171-00                          | 2     |
| 7    | Clamp, Backshell, Jackscrew, 9/15 Pin                                                                                                       | 115-01078-00                          | 2     |
| 8    | Screw, 4-40x.375, PHP, SS/P, w/Nylon                                                                                                        | 211-60234-10                          | 2     |
| 9    | Cover, Backshell, Jackscrew, 9/15 Pin                                                                                                       | 115-01079-00                          | 2     |
| 10   | Screw, 4-40x.187, FLHP100, SS/P, w/Nylon                                                                                                    | 211-63234-06                          | 2     |
| 11   | Screw, PHP, 8-32 x 0.312", Cad-Plated Steel, or<br>Screw, PHP, 8-32 x 0.312", Stainless                                                     | MS35206-242, or<br>MS51957-42         |       |
| 12   | Split Washer, #8 (0.045" compressed thickness), Cad-plated Steel, or<br>Split Washer, #8 (0.045" compressed thickness), Stainless           | MS35338-42, or<br>MS35338-137         |       |
| 13   | Flat washer, Cad-plated Steel, #8, 0.032" thick, 0.174" ID, 0.375" OD, or<br>Flat Washer, Stainless, #8, 0.032" thick, 0.174" ID, 0.375" OD | NAS1149FN832P,<br>or<br>NAS1149CN832R |       |
| 14   | Flat Braid, 1/16"                                                                                                                           | AA59569F36T0062                       | 1     |

Notes:

1. AS83519/1-X and braid are the preferred method for shield termination. Alternately, AS83519/2-X with pre-installed shield drain may be used.
2. Garmin Part Number. Included in kit p/n 011-03271-00.

*This area intentionally blank*



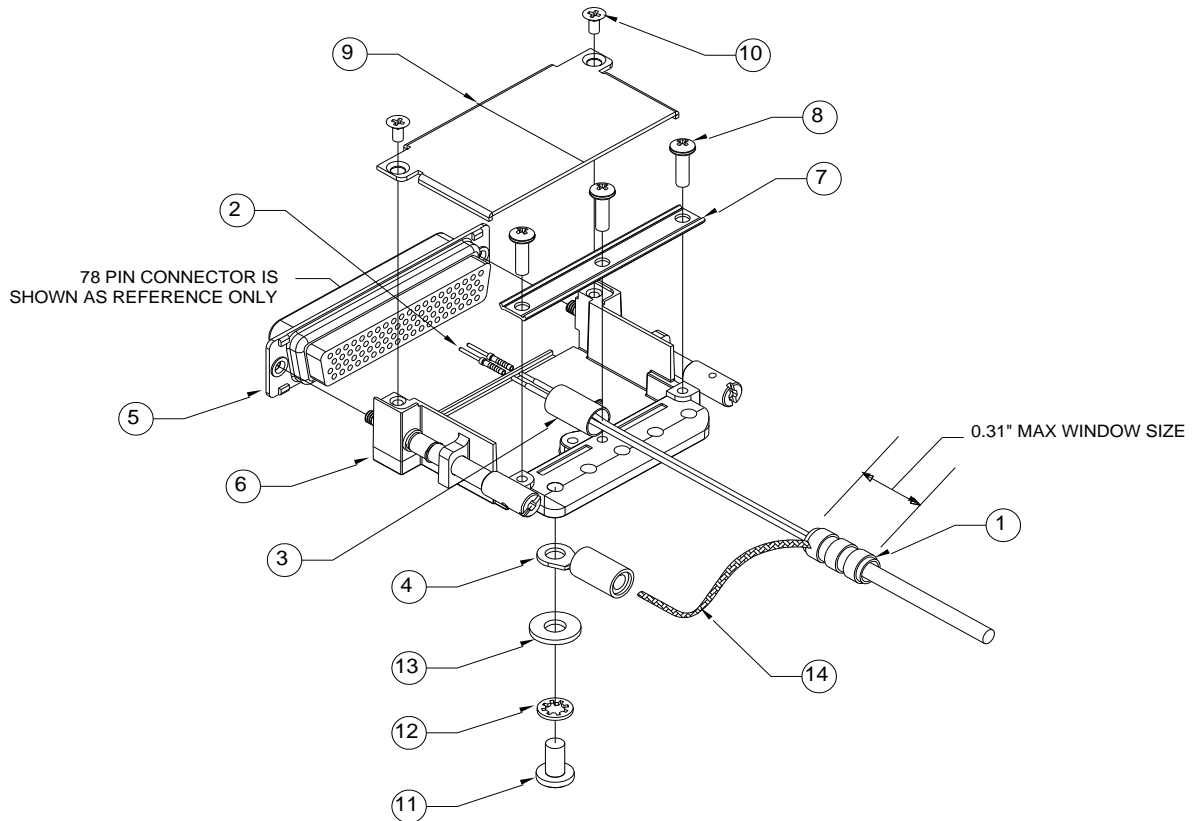
**Table 4-6: GAD 29/29B/29D 25-pin (P292) Connector Parts**

| Item | Description                                                                                                                                 | Part Number                           | Notes |
|------|---------------------------------------------------------------------------------------------------------------------------------------------|---------------------------------------|-------|
| 1    | Shield Termination, Solder Style, Insulated, Heat-Shrinkable, Environment Resistant (X = size)                                              | AS83519/1-X<br>(SAE-AS83519)          | 1     |
| 2    | Contact, Pin, MIL Crimp, Size 20                                                                                                            | M39029/64-369, or<br>336-00024-00     | 2     |
| 3    | Insulation Tape, Electrical, Self-Adhering, Unsupported Silicone Rubber                                                                     | A-A-59163<br>(MIL-I-46852C)           |       |
| 4    | Terminal, Lug, Crimp Style, Copper, Insulated, Ring Tongue, Bell Mouthed, Type II, Class I                                                  | MS25036-149                           |       |
| 5    | Connector, Plug, D-Sub, MIL Crimp Socket                                                                                                    | 330-00624-25                          | 2     |
| 6    | Backshell, Jackscrew, 25/44 Pin                                                                                                             | 125-00173-00                          | 2     |
| 7    | Clamp, Backshell, Jackscrew, 25/44 Pin                                                                                                      | 115-01078-02                          | 2     |
| 8    | Screw, 4-40x.375, PHP, SS/P, w/Nylon                                                                                                        | 211-60234-10                          | 2     |
| 9    | Cover, Backshell, Jackscrew, 25/44 Pin                                                                                                      | 115-01079-02                          | 2     |
| 10   | Screw, 4-40x.187, FLHP100, SS/P, w/Nylon                                                                                                    | 211-63234-06                          | 2     |
| 11   | Screw, PHP, 8-32 x 0.312", Cad-Plated Steel, or<br>Screw, PHP, 8-32 x 0.312", Stainless                                                     | MS35206-242, or<br>MS51957-42         |       |
| 12   | Split Washer, #8 (0.045" compressed thickness), Cad-plated Steel, or<br>Split Washer, #8 (0.045" compressed thickness), Stainless           | MS35338-42, or<br>MS35338-137         |       |
| 13   | Flat washer, Cad-plated Steel, #8, 0.032" thick, 0.174" ID, 0.375" OD, or<br>Flat Washer, Stainless, #8, 0.032" thick, 0.174" ID, 0.375" OD | NAS1149FN832P,<br>or<br>NAS1149CN832R |       |
| 14   | Flat Braid, 1/16"                                                                                                                           | AA59569F36T0062                       | 1     |

Notes:

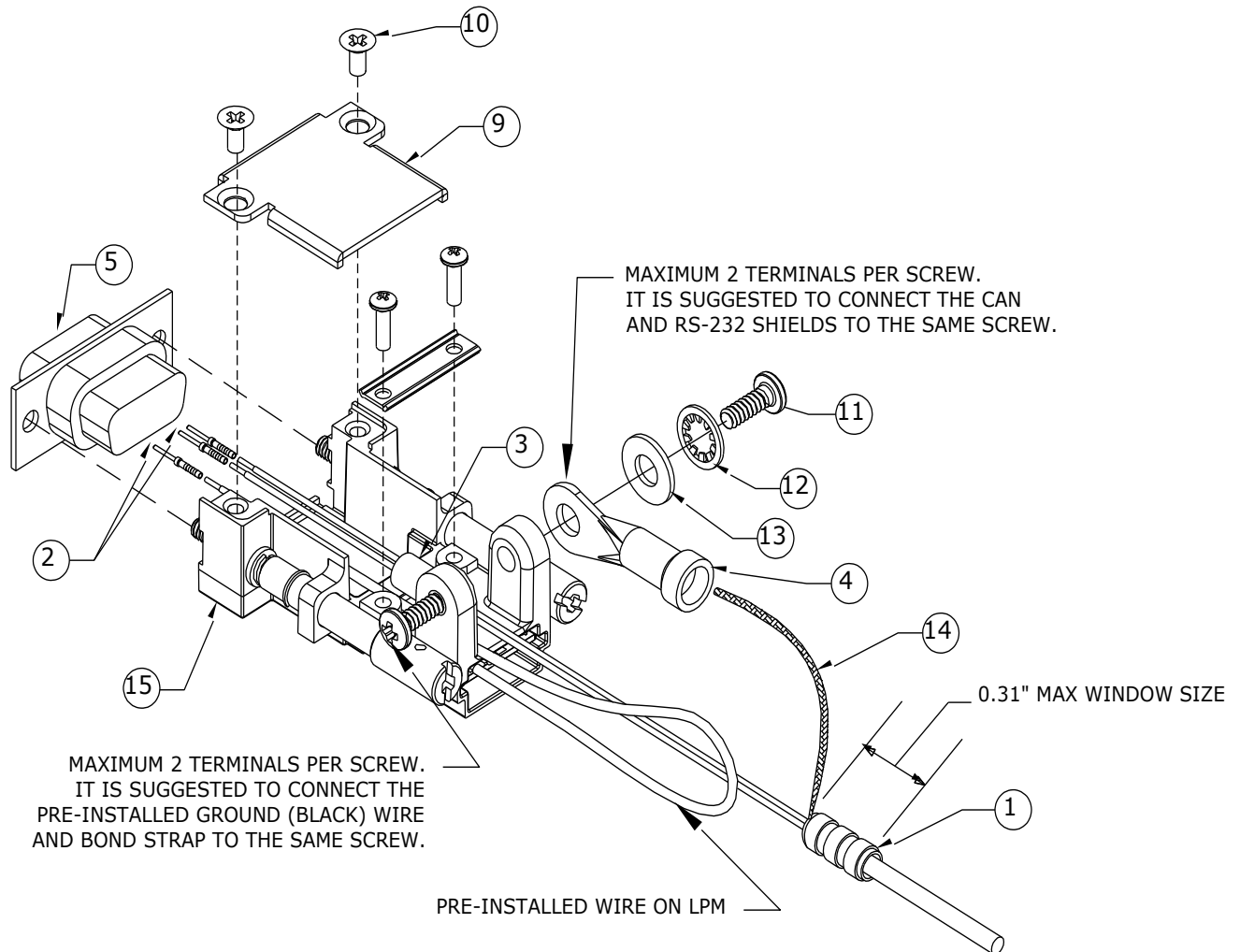
1. AS83519/1-X and braid are the preferred method for shield termination. Alternately, AS83519/2-X with pre-installed shield drain may be used.
2. Garmin Part Number. Included in kit p/n 011-03271-00.

*This area intentionally blank*



**Figure 4-49 GAD29(B)(D), GAD13, GMU11 Wiring Harness Connector Assembly**

*This area intentionally blank*

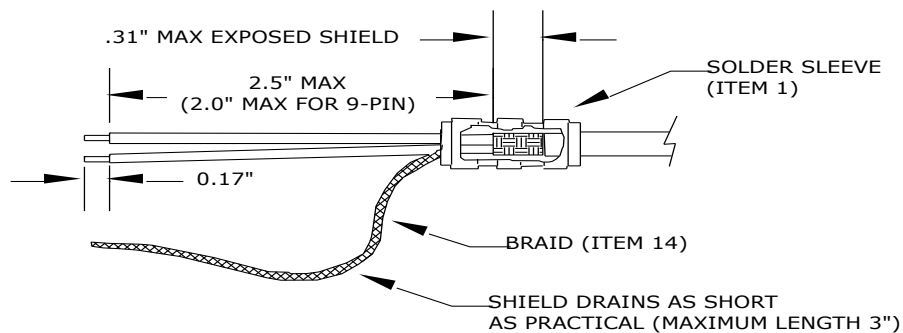


**NOTES FOR CONNECTOR ASSEMBLY:**

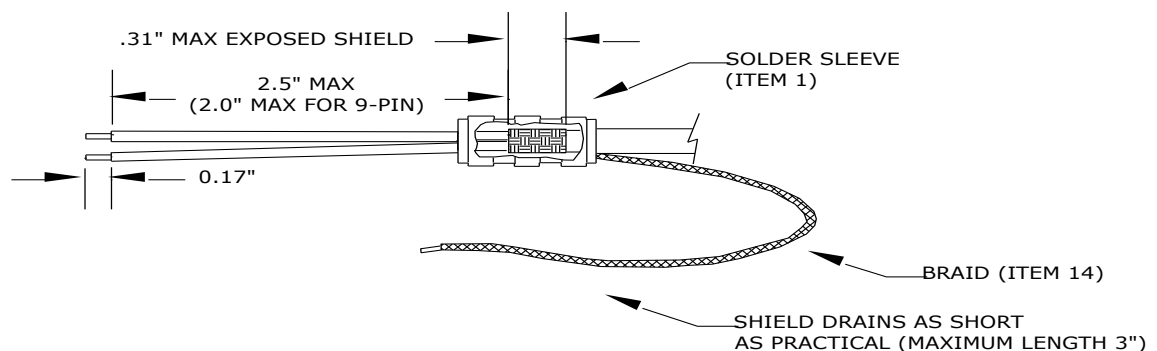
1. REFER TO LIGHTNING PROTECTION MODULE (LPM) WIRING INTERFACE INTERCONNECT FIGURE FOR SPECIFIC DISTANCES REQUIRED FOR ASSEMBLY.
2. A MAXIMUM OF FOUR TERMINALS ARE TO BE CONNECTED TO THE G5 BACKSHELL, TWO PER SCREW (ITEM 11 ABOVE).
  - 2.1. IT IS SUGGESTED THAT IF MULTIPLE DATA WIRE (CAN AND RS-232) SHIELDS ARE TO BE TERMINATED TO THE G5 BACKSHELL, THAT ALL SHIELDS ARE COMBINED INTO ONE TERMINAL.
    - 2.1.1. TWO SHIELD BRAIDS ARE TERMINATED USING A 14-16 GAUGE TERMINAL.
    - 2.1.1.1. THREE SHIELD BRAIDS ARE TERMINATED USING A 10-12 GAUGE TERMINAL.
3. THE PRE-INSTALLED GROUND WIRE (BLACK) CANNOT BE CONNECTED TO THE SAME SCREW AS THE CAN SHIELD TERMINATION SCREW.

**Figure 4-50 G5 LPM Wiring Harness Connector Assembly**

## SHIELDED CABLE PREPARATION (PREFERRED METHOD)



## SHIELDED CABLE PREPARATION (ALTERNATE METHOD)



**Figure 4-51 Shield Termination Methods**



### NOTE

*Max length of shield drain (braid) = 3.0 inches. If a splice requires extra length, max length of unshielded wire = 4.0 inches and max length of shield drain (braid) = 3.0 inches. It is acceptable to use shorter lengths.*

Prepare all of the shielded wires using one of the shield termination methods shown in Figure 4-51. Keep the shield drains as short as practical (3" max total length). See Table 4-4, Table 4-5, and Table 4-6 regarding numbers in parentheses in the following procedure.

1. Strip 2.5 inches (maximum) (2.0 inches maximum for 9-pin connectors) of the jacket to expose the shield braid.
2. Remove the exposed braid.
3. Carefully score the jacket 1/4 to 5/16 inches and remove the jacket to leave the braid exposed.
4. Slide a shield terminator (1) onto the exposed shield braid and insert shield braid drain (14) into shield terminator. Secure the shield terminator and braid drain to the shield using a heat gun approved for use with solder sleeves.
5. Strip the signal wires approximately 0.17 inches.
6. Crimp socket contacts (2) on to the signal wires.



7. Crimp ring terminals (4) on to the shield drain wires.
8. Repeat steps 1 through 7 as needed for the remaining shielded wires.
9. Insert the signal wire socket contacts into the appropriate locations in the D-sub connector (5).
10. Attach the shield drain ring terminals to the connector backshell shield block using the supplied screws and washers (11)(12)(13).
11. Wrap the wiring harness with silicone fusion tape (3) at the point where the strain relief clamp (7) and connector backshell (6) will contact the wiring harness.
12. Attach the strain relief clamp (7) to the connector backshell (6) using the supplied screws (8).



### CAUTION

*Placing the concave side of the strain relief clamp across the wiring harness will damage the wiring harness.*



### NOTE

*Only two ring terminals should be attached to each screw on the connector backshell shield ground. It is preferred that only two wires be terminated in each ring terminal. This will necessitate the use of a ring terminal, #8, insulated, 14-16 AWG (MS25036-153). If only a single wire is left or if only a single wire is needed for this connector a ring terminal, #8, insulated, 18-22 AWG (MS25036-149) can be used. If more wires exist for the connector than two per ring terminal, it is permissible to terminate three wires per ring terminal.*

13. Install the connector backshell cover (9) using the supplied screws (10).

*This area intentionally blank*





### 4.3 Weight and Balance

Weight and balance computations are required after the installation of the G5. Table 4-7 lists the weights associated with the G5 Electronic Flight Instrument. Refer to AC 43.13-1B, Chapter 10, for the weight and balance procedure covering the addition of equipment to the aircraft.

**Table 4-7: LRU Weights**

| <b>Item</b>                                  | <b>Weight</b> |
|----------------------------------------------|---------------|
| G5 with Battery, connector and mounting ring | .98 lbs       |
| GMU 11                                       | .26 lbs       |
| GAD 29                                       | .63 lbs       |
| GAD 29B                                      | .65 lbs       |
| Glare Shield Mounted GPS Antenna             | .20 lbs       |
| GAD 13                                       | .24 lbs       |

### 4.4 Electrical Load Analysis

If the current draw of the G5 unit(s), GMU 11, GAD 29/29B/29D, or GAD 13 is less than the removed equipment, then the aircraft's electrical load capacity can be shown to be adequate by analysis. If it is determined the modification results in an increase in electrical load, then it must be verified the electrical generation and reserve battery capacity remain adequate to support electrical loads essential to safe flight and landing of the aircraft.

#### 4.4.1 Aircraft with Existing Electrical Load Analysis

If there is an existing electrical load analysis for the aircraft, it must be updated to reflect the modification. It must show the electrical system has adequate capacity to supply power to the modified systems in all expected conditions. Refer to the aircraft manufacturer's documentation for guidance on revising and maintaining the electrical load analysis.

#### 4.4.2 Aircraft without Existing Electrical Load Analysis

Prior to undertaking a complete electrical load analysis, the net change to the electrical load resulting from the G5 installation should be determined. See Table 4-8 for a sample calculation. The results of this analysis will be used to determine how to proceed further.

*This area intentionally blank*



#### 4.4.2.1 Electrical Load is Reduced Following Modification

If calculations show the overall load on the electrical system is reduced as shown in the following example, no further analysis is required. This assumes the electrical system was within all limits prior to the G5, GMU 11, GAD 29/29B/29D, or GAD 13 installation. Record the new electrical load calculations.

**Table 4-8: Sample Net Electrical Load Change Calculation**

| Items removed from aircraft: | Electrical Load (Amps) <sup>1</sup> |
|------------------------------|-------------------------------------|
|                              |                                     |
|                              |                                     |
|                              |                                     |
| SUBTOTAL                     |                                     |

| Items added to aircraft |                               |         |
|-------------------------|-------------------------------|---------|
| G5                      | 14 V (typical) <sup>(1)</sup> | .200 A  |
|                         | 28 V (typical) <sup>(1)</sup> | .100 A  |
|                         |                               |         |
| GMU 11                  | 14 V (typical) <sup>(1)</sup> | .100 A  |
|                         | 28 V (typical) <sup>(1)</sup> | .100 A  |
|                         |                               |         |
| GAD 29/29B/29D          | 14 V (typical) <sup>(1)</sup> | .200 A  |
|                         | 28 V (typical) <sup>(1)</sup> | .100 A  |
|                         |                               |         |
| GAD 13                  | 14 V (typical) <sup>(1)</sup> | 0.120 A |
|                         | 28 V (typical) <sup>(1)</sup> | 0.050 A |
|                         |                               |         |
| SUBTOTAL                |                               |         |

**NET CHANGE IN BUS LOAD**  
(NEW BUS LOAD – OLD BUS LOAD)

Notes:

- (1) Use 14 V or 28 V typical current draw depending on aircraft system when performing this calculation.



#### 4.4.2.2 Electrical Load is Increased Following Modification

If it is determined the electrical load has increased an appreciable amount, a complete electrical load analysis must be performed to show the capacity of the electrical system is sufficient for the additional electrical load. For guidance on performing an electrical load analysis, refer to ASTM F 2490-05, Standard Guide for Aircraft Electrical Load and Power Source Capacity Analysis. Alternatively, the loads under various operating conditions may be measured, as described in Section 4.4.2.3.

#### 4.4.2.3 Performing an Electrical Load Analysis by Measurement

This section describes how to perform an electrical load analysis for a single alternator-single battery electrical system. These procedures may be modified accordingly for aircraft with multiple batteries or alternators, and it must be shown the maximum electrical demand does not typically exceed 80% of the electrical system capacity.

In this section the following definitions are used:

**normal operation:** the primary electrical power generating system is operating normally.

**emergency operation:** the primary electrical power generating system is inoperative and a back-up electrical power generating system is being used. This typically requires load shedding of non-essential equipment to provide adequate electrical power to essential required equipment for safe flight and landing of the airplane.

Either an in-circuit or clamp-on ammeter can be used for current measurement. The instrument used must be calibrated and must be capable of reading current to the nearest 0.5 A, or better.

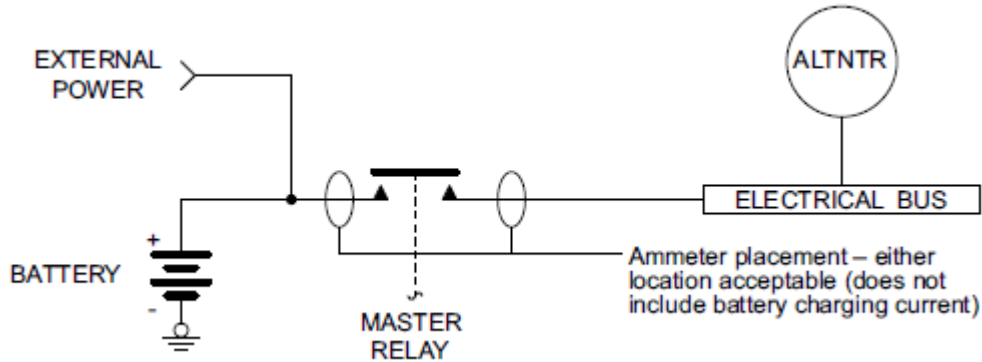
1. Record the continuous load rating for the alternator and battery.
2. Compile a list of electrical loads on the aircraft (generally, this is just a list of circuit breakers and circuit breaker switches).
3. Identify whether each load is *continuous* (e.g. GPS) or *intermittent* (e.g. stall warning horn, landing gear).
4. Using the worst-case flight condition, identify whether each load is used in a particular phase of flight for *normal* operation. If some loads are mutually exclusive and will not be turned on simultaneously (e.g. pitot heat and air conditioning), use only those loads for the worst-case condition.
5. Identify whether each load is used in a particular phase of flight for emergency operation. As a minimum, these systems generally include:
  - COM Radio #1
  - NAV Radio #1
  - Transponder and associated altitude source
  - Audio Panel
  - Stall Warning System (if applicable)
  - Pitot Heat
  - Landing Light (switched on during landing only)
  - Instrument Panel Dimming

6. Insert/attach the ammeter in the line from the external power source to the master relay circuit as shown in Figure 4-52. This will eliminate errors due to the charging current drawn by the battery.



## CAUTION

To avoid damage to equipment, ensure the ammeter is capable of handling the expected load.



**Figure 4-52 Ammeter Placement for Current Measurements**

7. Ensure all circuit breakers are closed.
8. Apply external power to the aircraft. The voltage of the power source should be set to the nominal alternator voltage (usually 13.8 VDC or 27.5 VDC).
9. Turn on the battery master switch.



## NOTE

*Intermittent electrical loads are not measured. It is assumed if additional current is required beyond what the alternator can supply, this short-duration demand will be provided by the battery.*

10. Set the lighting as described below. These settings will be used for every current measurement which follows:
  - Set instrument panel and flood lights to maximum brightness.
  - Set displays with a backlight to 50% brightness
11. Using the tabulation completed above, switch on all *continuous* electrical loads used for the taxiing phase and record the current measured by the ammeter (measurement (a) in Figure 4-53). The autopilot circuit breaker (if installed) should be closed, but the autopilot should not be engaged.



## WARNING

*Pitot heat should be switched on only long enough to take the current measurement and then switched off to avoid injury to personnel or damage to the Pitot tube.*

12. Using the tabulation completed above, switch on all continuous electrical loads used for the **normal** takeoff/landing phase and record the current measured by the ammeter. Measurements must be taken with the landing lights ON and OFF (measurements (b1) and (b2) in Figure 4-53).
13. Engage the autopilot (if installed).
14. Using the tabulation completed above, switch on all continuous electrical loads which are used for the **normal** cruise phase and record the current measured by the ammeter measurement (c) in Figure 4-53.
15. Using the tabulation completed above, switch on all continuous electrical loads used for the **emergency** cruise phase and record the current measured by the ammeter.
16. Using the tabulation completed above, switch on all continuous electrical loads used for the emergency landing phase and record the current measured by the ammeter.
17. Using the values measured and recorded, complete the ELA using the blank form in Figure 4-53 and Figure 4-54.
18. Verify the maximum electrical load does not exceed 80% of the electrical system capacity. See example in Figure 4-55 and Figure 4-56.



**NOTE**

*Electrical loads in excess of 80% but not greater than 95% of electrical system capacity are permitted during the takeoff/landing phase of flight when landing light(s) are switched on.*

*This area intentionally blank*





**AIRPLANE ELECTRICAL LOAD TABULATION FORM (CONTINUED)**

Date: \_\_\_\_\_ Tail Number: \_\_\_\_\_ Phase(s) of flight during which circuit/system is used

| Circuit/System                                | Circuit Breaker Number | Operating Time | Normal Operation |                    |               | Emergency Operation |             |
|-----------------------------------------------|------------------------|----------------|------------------|--------------------|---------------|---------------------|-------------|
|                                               |                        |                | Taxiing 10 min   | TO/Land 10 min     | Cruise 60 min | Cruise              | Land 10 min |
|                                               |                        |                |                  |                    |               |                     |             |
|                                               |                        |                |                  |                    |               |                     |             |
|                                               |                        |                |                  |                    |               |                     |             |
|                                               |                        |                |                  |                    |               |                     |             |
|                                               |                        |                |                  |                    |               |                     |             |
|                                               |                        |                |                  |                    |               |                     |             |
|                                               |                        |                |                  |                    |               |                     |             |
| Total current used (amps):                    |                        |                | (a)              | Ldg Lt ON (b1)     | (c)           | (d)                 | (e)         |
| ÷ Alternator rating (amps):                   |                        |                |                  | Ldg Lt OFF (b2)    |               |                     |             |
| x 100% = Percent of alternator capacity used: |                        |                | % (< 80%)        | Ldg Lt ON (< 95%)  | % (< 80%)     | N/A                 | N/A         |
|                                               |                        |                |                  | Ldg Lt OFF (< 80%) |               |                     |             |
| Pass/Fail:                                    |                        |                |                  |                    |               |                     |             |

Notes:

Figure 4-54 Blank Electrical Load Tabulation Form, Sheet 2 of 2



### ELECTRICAL LOAD TABULATION FORM

Date: 02/14/14 Tail Number: NXXXX

| Circuit/System     | Circuit Breaker Number | Operating Time | Phase(s) of flight during which circuit/system is used |                                     |                                     |                                     |                                     |
|--------------------|------------------------|----------------|--------------------------------------------------------|-------------------------------------|-------------------------------------|-------------------------------------|-------------------------------------|
|                    |                        |                | Normal Operation                                       |                                     |                                     | Emergency Operation                 |                                     |
|                    |                        |                | Taxiing<br>10 min                                      | TD/Land<br>10 min                   | Cruise<br>60 min                    | Cruise                              | Land<br>10 min                      |
| ALTERNATOR FIELD   |                        | Continuous     | <input checked="" type="checkbox"/>                    | <input checked="" type="checkbox"/> | <input checked="" type="checkbox"/> | <input type="checkbox"/>            | <input type="checkbox"/>            |
| ANNUNCIATOR PANEL  |                        | Continuous     | <input checked="" type="checkbox"/>                    | <input checked="" type="checkbox"/> | <input checked="" type="checkbox"/> | <input checked="" type="checkbox"/> | <input checked="" type="checkbox"/> |
| VACUUM WARNING     |                        | Intermittent   | <input type="checkbox"/>                               | <input type="checkbox"/>            | <input type="checkbox"/>            | <input type="checkbox"/>            | <input type="checkbox"/>            |
| GEAR WARNING       |                        | Intermittent   | <input type="checkbox"/>                               | <input type="checkbox"/>            | <input type="checkbox"/>            | <input type="checkbox"/>            | <input type="checkbox"/>            |
| GEAR ACTUATOR      |                        | Intermittent   | <input type="checkbox"/>                               | <input type="checkbox"/>            | <input type="checkbox"/>            | <input type="checkbox"/>            | <input type="checkbox"/>            |
| CLUSTER GAUGE      |                        | Continuous     | <input checked="" type="checkbox"/>                    | <input checked="" type="checkbox"/> | <input checked="" type="checkbox"/> | <input checked="" type="checkbox"/> | <input checked="" type="checkbox"/> |
| IGNITION           |                        | Intermittent   | <input type="checkbox"/>                               | <input type="checkbox"/>            | <input type="checkbox"/>            | <input type="checkbox"/>            | <input type="checkbox"/>            |
| PFD                |                        | Continuous     | <input checked="" type="checkbox"/>                    | <input checked="" type="checkbox"/> | <input checked="" type="checkbox"/> | <input checked="" type="checkbox"/> | <input checked="" type="checkbox"/> |
| TURN COORDINATOR   |                        | Continuous     | <input checked="" type="checkbox"/>                    | <input checked="" type="checkbox"/> | <input checked="" type="checkbox"/> | <input type="checkbox"/>            | <input type="checkbox"/>            |
| GEAR RELAY         |                        | Intermittent   | <input type="checkbox"/>                               | <input type="checkbox"/>            | <input type="checkbox"/>            | <input type="checkbox"/>            | <input type="checkbox"/>            |
| ADC                |                        | Continuous     | <input checked="" type="checkbox"/>                    | <input checked="" type="checkbox"/> | <input checked="" type="checkbox"/> | <input checked="" type="checkbox"/> | <input checked="" type="checkbox"/> |
| PANEL LIGHTS       |                        | Continuous     | <input checked="" type="checkbox"/>                    | <input checked="" type="checkbox"/> | <input checked="" type="checkbox"/> | <input checked="" type="checkbox"/> | <input checked="" type="checkbox"/> |
| GLARESHIELD LIGHTS |                        | Continuous     | <input checked="" type="checkbox"/>                    | <input checked="" type="checkbox"/> | <input checked="" type="checkbox"/> | <input checked="" type="checkbox"/> | <input checked="" type="checkbox"/> |
| AHRS               |                        | Continuous     | <input checked="" type="checkbox"/>                    | <input checked="" type="checkbox"/> | <input checked="" type="checkbox"/> | <input checked="" type="checkbox"/> | <input checked="" type="checkbox"/> |
| FLAP ACTUATOR      |                        | Intermittent   | <input type="checkbox"/>                               | <input type="checkbox"/>            | <input type="checkbox"/>            | <input type="checkbox"/>            | <input type="checkbox"/>            |
| COM 1              |                        | Continuous     | <input checked="" type="checkbox"/>                    | <input checked="" type="checkbox"/> | <input checked="" type="checkbox"/> | <input checked="" type="checkbox"/> | <input checked="" type="checkbox"/> |
| GPS/NAV 1          |                        | Continuous     | <input checked="" type="checkbox"/>                    | <input checked="" type="checkbox"/> | <input checked="" type="checkbox"/> | <input checked="" type="checkbox"/> | <input checked="" type="checkbox"/> |
| COM 2              |                        | Continuous     | <input checked="" type="checkbox"/>                    | <input checked="" type="checkbox"/> | <input checked="" type="checkbox"/> | <input type="checkbox"/>            | <input type="checkbox"/>            |
| GPS/NAV 2          |                        | Continuous     | <input checked="" type="checkbox"/>                    | <input checked="" type="checkbox"/> | <input checked="" type="checkbox"/> | <input type="checkbox"/>            | <input type="checkbox"/>            |
| AUTOPILOT [1]      |                        | Continuous     | <input checked="" type="checkbox"/>                    | <input checked="" type="checkbox"/> | <input checked="" type="checkbox"/> | <input type="checkbox"/>            | <input type="checkbox"/>            |
| AUDIO PANEL        |                        | Continuous     | <input checked="" type="checkbox"/>                    | <input checked="" type="checkbox"/> | <input checked="" type="checkbox"/> | <input checked="" type="checkbox"/> | <input checked="" type="checkbox"/> |
| RADIO BLOWER       |                        | Continuous     | <input checked="" type="checkbox"/>                    | <input checked="" type="checkbox"/> | <input checked="" type="checkbox"/> | <input type="checkbox"/>            | <input type="checkbox"/>            |
| ADF                |                        | Continuous     | <input checked="" type="checkbox"/>                    | <input checked="" type="checkbox"/> | <input checked="" type="checkbox"/> | <input type="checkbox"/>            | <input type="checkbox"/>            |
| TRANSPONDER        |                        | Continuous     | <input checked="" type="checkbox"/>                    | <input checked="" type="checkbox"/> | <input checked="" type="checkbox"/> | <input checked="" type="checkbox"/> | <input checked="" type="checkbox"/> |
| GDL 69             |                        | Continuous     | <input checked="" type="checkbox"/>                    | <input checked="" type="checkbox"/> | <input checked="" type="checkbox"/> | <input type="checkbox"/>            | <input type="checkbox"/>            |
| GTS 8X5            |                        | Continuous     | <input checked="" type="checkbox"/>                    | <input checked="" type="checkbox"/> | <input checked="" type="checkbox"/> | <input type="checkbox"/>            | <input type="checkbox"/>            |
| JPI ENGINE MONITOR |                        | Continuous     | <input checked="" type="checkbox"/>                    | <input checked="" type="checkbox"/> | <input checked="" type="checkbox"/> | <input checked="" type="checkbox"/> | <input checked="" type="checkbox"/> |
| BOSE HEADSETS      |                        | Continuous     | <input checked="" type="checkbox"/>                    | <input checked="" type="checkbox"/> | <input checked="" type="checkbox"/> | <input checked="" type="checkbox"/> | <input checked="" type="checkbox"/> |
| ALTITUDE ENCODER   |                        | Continuous     | <input checked="" type="checkbox"/>                    | <input checked="" type="checkbox"/> | <input checked="" type="checkbox"/> | <input checked="" type="checkbox"/> | <input checked="" type="checkbox"/> |
| STROBE LIGHT       |                        | Continuous     | <input checked="" type="checkbox"/>                    | <input checked="" type="checkbox"/> | <input checked="" type="checkbox"/> | <input checked="" type="checkbox"/> | <input checked="" type="checkbox"/> |
| NAV LIGHTS         |                        | Continuous     | <input checked="" type="checkbox"/>                    | <input checked="" type="checkbox"/> | <input checked="" type="checkbox"/> | <input checked="" type="checkbox"/> | <input checked="" type="checkbox"/> |
| RECOGNITION LIGHTS |                        | Continuous     | <input checked="" type="checkbox"/>                    | <input checked="" type="checkbox"/> | <input checked="" type="checkbox"/> | <input checked="" type="checkbox"/> | <input checked="" type="checkbox"/> |
| LANDING LIGHT      |                        | Continuous     | <input checked="" type="checkbox"/>                    | <input checked="" type="checkbox"/> | <input type="checkbox"/>            | <input type="checkbox"/>            | <input checked="" type="checkbox"/> |
| PITOT HEAT         |                        | Continuous     | <input checked="" type="checkbox"/>                    | <input checked="" type="checkbox"/> | <input checked="" type="checkbox"/> | <input checked="" type="checkbox"/> | <input checked="" type="checkbox"/> |
| BOOST PUMP         |                        | Continuous     | <input type="checkbox"/>                               | <input checked="" type="checkbox"/> | <input checked="" type="checkbox"/> | <input checked="" type="checkbox"/> | <input checked="" type="checkbox"/> |

Figure 4-55 Sample Completed Electrical Load Tabulation Form, Sheet 1 of 2





**ELECTRICAL LOAD TABULATION FORM (CONTINUED)**

Date: 02/14/14 Tail Number: NXXXX

Phase(s) of flight during which circuit/system is used

| Circuit/System                                | Circuit Breaker Number | Operating Time | Normal Operation            |                                                                                           |                             | Emergency Operation      |                          |
|-----------------------------------------------|------------------------|----------------|-----------------------------|-------------------------------------------------------------------------------------------|-----------------------------|--------------------------|--------------------------|
|                                               |                        |                | Taxiing 10 min              | TD/Land 10 min                                                                            | Cruise 60 min               | Cruise                   | Land 10 min              |
|                                               |                        |                | <input type="checkbox"/>    | <input type="checkbox"/>                                                                  | <input type="checkbox"/>    | <input type="checkbox"/> | <input type="checkbox"/> |
|                                               |                        |                | <input type="checkbox"/>    | <input type="checkbox"/>                                                                  | <input type="checkbox"/>    | <input type="checkbox"/> | <input type="checkbox"/> |
|                                               |                        |                | <input type="checkbox"/>    | <input type="checkbox"/>                                                                  | <input type="checkbox"/>    | <input type="checkbox"/> | <input type="checkbox"/> |
|                                               |                        |                | <input type="checkbox"/>    | <input type="checkbox"/>                                                                  | <input type="checkbox"/>    | <input type="checkbox"/> | <input type="checkbox"/> |
|                                               |                        |                | <input type="checkbox"/>    | <input type="checkbox"/>                                                                  | <input type="checkbox"/>    | <input type="checkbox"/> | <input type="checkbox"/> |
|                                               |                        |                | <input type="checkbox"/>    | <input type="checkbox"/>                                                                  | <input type="checkbox"/>    | <input type="checkbox"/> | <input type="checkbox"/> |
|                                               |                        |                | <input type="checkbox"/>    | <input type="checkbox"/>                                                                  | <input type="checkbox"/>    | <input type="checkbox"/> | <input type="checkbox"/> |
|                                               |                        |                | <input type="checkbox"/>    | <input type="checkbox"/>                                                                  | <input type="checkbox"/>    | <input type="checkbox"/> | <input type="checkbox"/> |
|                                               |                        |                | <input type="checkbox"/>    | <input type="checkbox"/>                                                                  | <input type="checkbox"/>    | <input type="checkbox"/> | <input type="checkbox"/> |
|                                               |                        |                | <input type="checkbox"/>    | <input type="checkbox"/>                                                                  | <input type="checkbox"/>    | <input type="checkbox"/> | <input type="checkbox"/> |
| Total current used (amps):                    |                        |                | 47.5<br>(a)                 | 60<br>Ldg Lt ON<br>(b1)<br><br>44.7<br>Ldg Lt OFF<br>(b2)                                 | 43.5<br>(c)                 | 34.0<br>(d)              | 48.1<br>(e)              |
| + Alternator rating (amps):                   |                        |                | 70                          |                                                                                           |                             |                          |                          |
| x 100% = Percent of alternator capacity used: |                        |                | 68 %<br>( <u>&lt; 80%</u> ) | 86 %<br>Ldg Lt ON<br>( <u>&lt; 95%</u> )<br><br>64 %<br>Ldg Lt OFF<br>( <u>&lt; 80%</u> ) | 62 %<br>( <u>&lt; 80%</u> ) | N/A                      | N/A                      |
| Pass/Fail:                                    |                        |                | PASS                        | PASS                                                                                      | PASS                        |                          |                          |

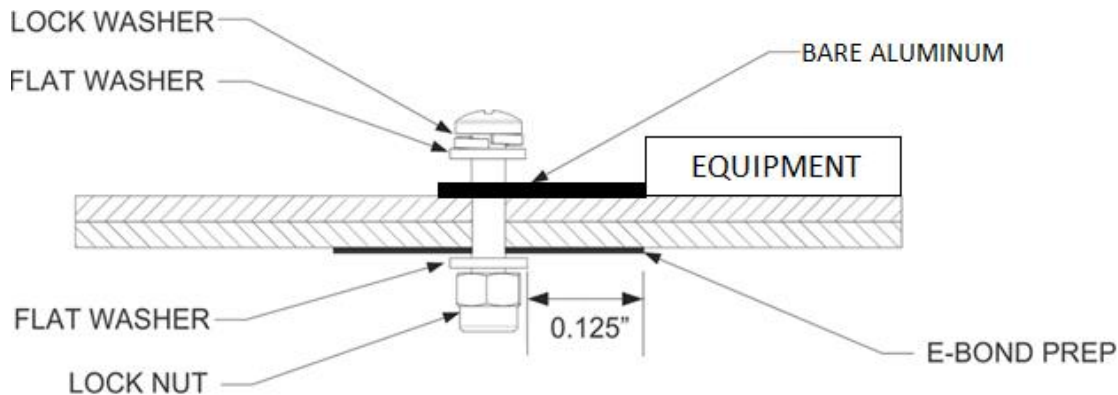
Notes:

Figure 4-56 Sample Completed Electrical Load Tabulation Form, Sheet 2 of 2

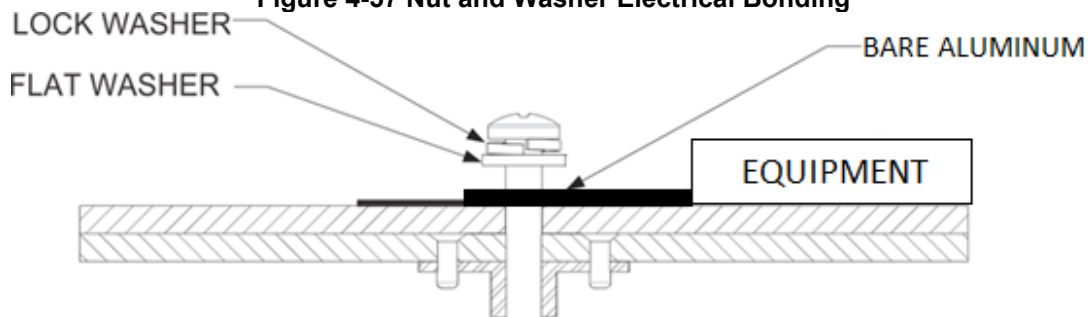
## 4.5 Electrical Bonding

The GAD 29/29B/29D and GAD 13 are the LRUs installed by this STC that require chassis bonding. Sections 4.5, 4.5.1, 4.5.2, 4.5.3 present data on acceptable methods of electrical bonding for the GAD 29/29B and GAD 13. For G5 and GMU 11 bonding strap requirements and associated installations, refer to section 4.5.4 and 4.5.5.

GAD 29/29B/29D and GAD 13 electrical bonding can be achieved with mounting hardware (rivets, bolts, nuts, washers, etc.). A reliable electrical bond relies on mated surfaces to be clean of any primer/grease/dirt. When bolts are used to secure racks/brackets/etc. and are relied upon for electrical bond, in lieu of the mating surfaces of the racks/brackets/etc. then the area under the head of the bolt/screw or washer must be free of primer and a burnished area should be prepared that is at least 0.125 inch wider than the head of the bolt or the washer (if used) under the head. If primer or film was removed to achieve this then any exposed area still visible after the bond is completed must be refinished with the original finish or other suitable film (e.g. primer) or coating, ref ARP1870. If the bolt is secured with washer and nut then a similar burnish area as described above shall occur between the washer and the mounting structure, see Figure 4-57. Rivets used to mechanically attach brackets/shelves/etc. provide an inherent electrical bond through the rivets and require no additional bond preparation. Similarly riveted nut plates do not need any special bonding preparation and can be relied upon to provide electrical bond between the fastener and the nut plate. The top or bottom side of the Garmin racks or equipment flanges do not need any special bond preparations, see Figure 4-58. Additional details on how to accomplish electrical bonding can also be found in SAE ARP1870 section 5.



**Figure 4-57 Nut and Washer Electrical Bonding**



**Figure 4-58 Nut Plate Electrical Bonding**

When equipment is mounted to honeycomb shelves, the face sheets must be metal. The honeycomb material between the face sheets is not conductive and therefore care must be taken to make sure proper



bonding of the equipment has taken place. The top and bottom face sheets must be grounded to each other and one of the face sheets must be grounded to the airframe.

The instrument panel must be of metal construction so that remotely mounted units have a metal ground reference back to the other G5 interfacing equipment mounted on the instrument panel. For metal aircraft the latter is achieved inherently through the metallic aircraft structure. For composite aircraft a ground plane (or reference) may need to be created to achieve a comparable ground. This procedure is described in Section 4.5.2.

Electrical equipment, connectors with shields connected to backshell, and supporting brackets shall be electrically bonded. The electrical bond shall achieve a direct current (DC) resistance of 2.5 mΩ or less between faying surface, shelves, and the aircraft structure. Compliance shall be verified by inspection.

#### 4.5.1 Metal Aircraft

The GAD 29/29B/29D and GAD 13 support brackets require a resistance value of 2.5 milliohms or less between individual mating surfaces. For general steps on how to prepare aluminum surfaces for electrical bonding refer to Section 4.5.3.

If the instrument panel is attached by vibration mounts, verify that the mounts are grounded to the metallic airframe structure by means of a bonding jumper. Ensure that the installed bonding jumper meets the following specifications.

1. The braid is a 7/16" or wider tubular braid (part number QQB575R30T437, 24,120 circular mils) or a 3/4" or wider flat braid (part number QQB575F36T781, 20,800 circular mils).
2. The braid contains a terminal lug (mil-spec MS20659-130) at each end.
3. The strap length is as short as possible, not exceeding 6 inches.

Ensure that each terminal lug is secured to its respective mating surface with one #10 steel bolt and one flat washer (part number AN970-3). Lugs and washers should be center-aligned and flush on all outside edges. These components should be in full contact with the mating surface.

#### 4.5.2 Nonmetallic Aircraft



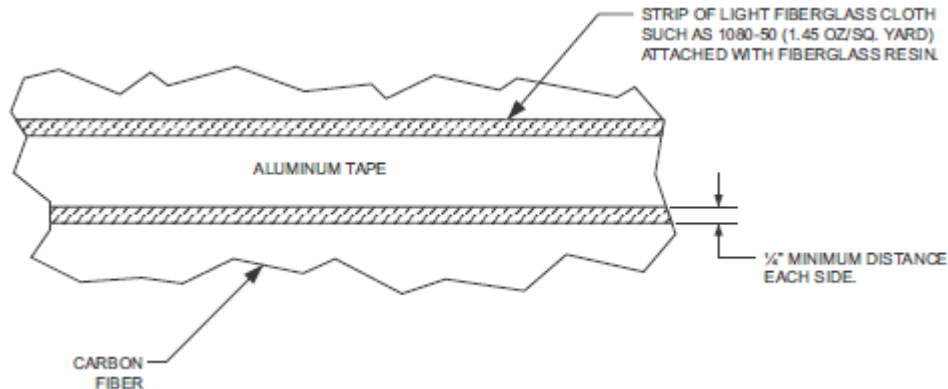
##### NOTE

*Carbon reinforced composite (with or without mesh) or fiberglass with mesh is considered to be conductive. Wood, Kevlar and fiberglass without mesh is considered to be non-conductive.*

If the equipment is mounted in the metallic instrument panel then the bonding should be accomplished like that for metal aircraft (Section 4.5.1). For composite areas of the aircraft the GAD 29/29B/29D and GAD 13 must be electrically bonded to the metallic instrument panel either directly through the unit remote install/mounting rack or with heavy-duty dead soft aluminum tape such as 3M Heavy Duty Aluminum Foil Tape 438. The following guidance should be used for locating and bonding the LRU:

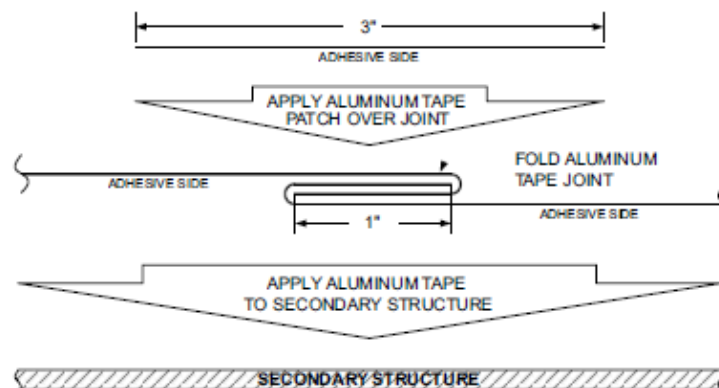
1. Identify a location for the LRU which is close to the instrument panel or the grounding structure for the instrument panel.
2. Identify a route between the LRU location and the instrument panel ground that will accommodate a strip of aluminum tape with a width of at least four inches and a length-to-width ratio of 7:1.
3. If the tape will come in contact with carbon composite material, the tape must be electrically isolated from the carbon composite material to prevent corrosion due to dissimilar materials.

Secure a thin layer of fiberglass cloth to the carbon fiber with fiberglass resin as shown in Figure 4-59.



**Figure 4-59 Fiberglass Insulation for Carbon Fiber Material**

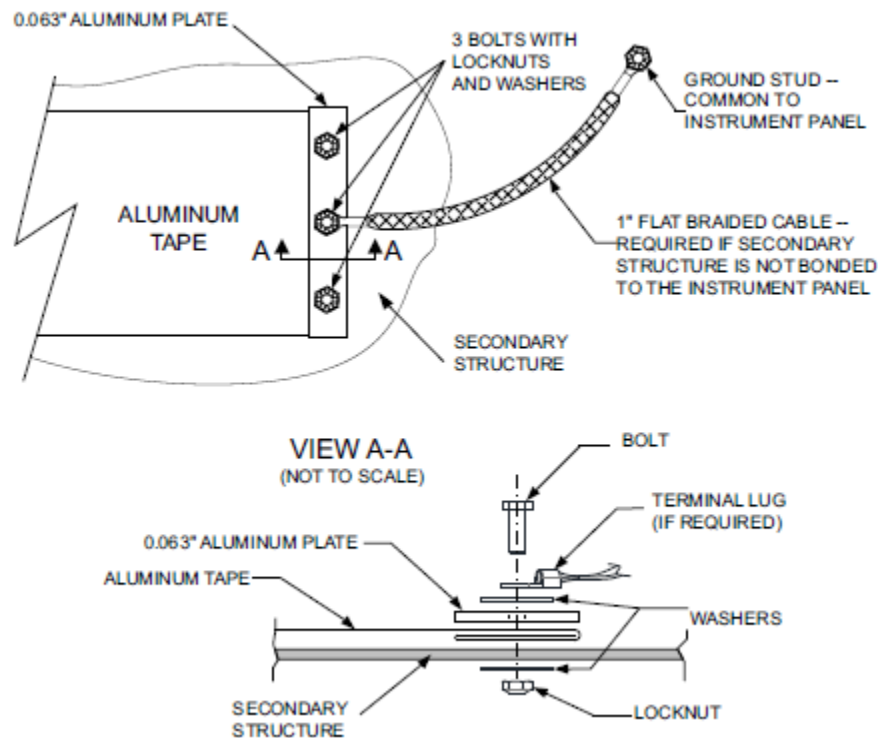
4. Identify a grounding location. The ground must be a bare metal surface on the instrument panel or grounding structure for the instrument panel. If it is impractical to reach a grounding location with aluminum tape then:
  - a. The tape shall meet a 5:1 length to width ratio.
  - b. The bond strap shall be one inch wide and no longer than five inches.
5. Prepare the aluminum surface at the ground location outlined in Section 4.5.3 or identify a ground stud to which the braid can be attached. Any new ground stud shall also be prepared for electrical bonding.
6. Route the tape between the LRU mount and the grounding location for the instrument panel. If needed to maintain the 7:1 length-to-width ratio, the tape can be overlapped in more than one strip.
7. If two pieces of tape need to be joined end-to-end, they can be joined as illustrated in Figure 4-60.



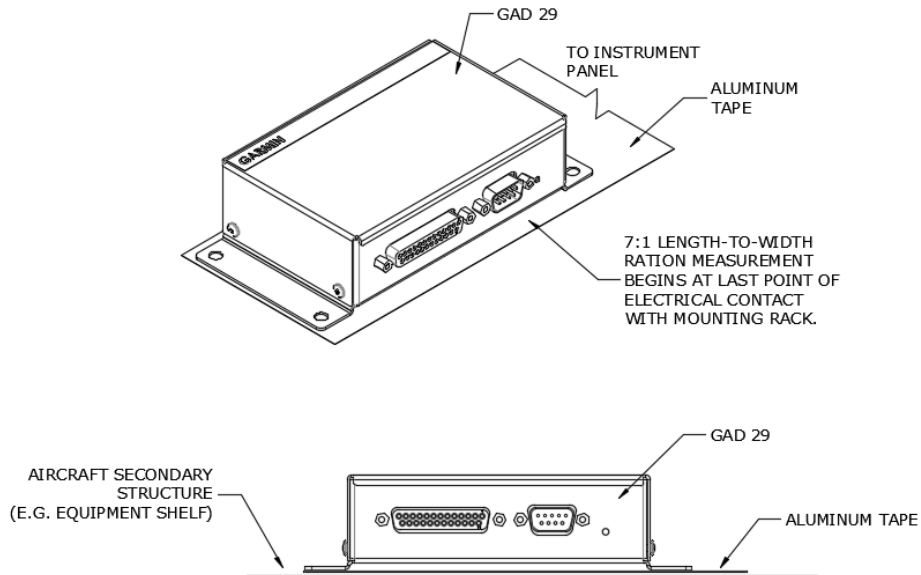
**Figure 4-60 Aluminum Tape Joint**

8. Fold the end of the tape over twice for added thickness at the prepared grounding location. Refer to Figure 4-61. Apply 3" wide tape over the seam.
9. The tape shall not have any tears in the joint or along the length of the tape as tears will degrade the bonding performance.
10. Electrical bond preparation for all aluminum-to-aluminum interfaces per SAE ARP1870 section 5.1 and 5.5.

11. If a bonding strap will be used to reach the grounding location, secure the end of the tape to the secondary composite surface as shown in Figure 4-61. Note that the procedure for installing mounting bolts applies only to secondary aircraft structures, not to primary structure or structural load-carrying members. The tape shall meet 5:1 length to width ratio if a bonding strap is used. The bonding strap shall be one inch wide and no longer than five inches. Refer to Figure 4-61.
12. Terminate both ends of the bonding strap with MS20659-130 terminal lugs.
13. Install AN960C10 washer between the terminal lug and the mating metal surface and secure with a #10 steel bolt. Ensure that the lug and washer are centered and in full contact with the mating surface with no overhang when secured.
14. Secure the end of the tape in place using a 0.063" piece of aluminum using three bolts and nuts. Refer to Figure 4-61.
15. Secure the aluminum tape to the GAD 29/29B/29D, GAD 13, or mounting rack as shown in Figure 4-62.
16. Verify that the resistance between tape and the local grounding location does not exceed 2.5 mΩ.



**Figure 4-61 Aluminum Tape Ground Termination**



**Figure 4-62 GAD 29/29B/29D Aluminum Tape Installation (GAD 13 similar)**

### 4.5.3 Aluminum Surface Preparation

In order to prepare the aluminum surface for proper bonding, the following general steps should be followed. For a detailed procedure, reference SAE ARP1870, Sections 5.1 and 5.5.

1. Clean grounding location with solvent.
2. Remove non-conductive films or coatings from the grounding location. When area is cleaned around fastener heads or washers the area cleaned should be 0.125 inches wider than the foot print of the washer or the bolt head.
3. Apply a chemical conversion coat such as Alodine 1200 to the bare metal.
4. Once the chemical conversion coat is dry, clean the area.
5. Install bonding aluminum tape or equipment at grounding location.
6. After the bond is complete, if any films or coatings were removed from the surface, reapply a suitable film or coating to the surrounding area.

### 4.5.4 Bonding Strap for G5 and GMU 11

A bonding strap is required for the G5. A bonding strap is required for a GMU 11 mounted in a non-metallic wingtip when wires connected to the GMU 11 are not covered in metal overbraid (see APPENDIX D for specific requirements). A bonding strap is required for a GMU 11 mounted in any other aircraft location or GMU 11 wires are not covered in overbraid. Use the following guidance to create a bond strap for the required installations. The bonding strap must be **less than 10 inches in length** and must be connected from the backshell to a #10 ground stud. Below is a list of approved metal braids with their accompanying terminal rings that can be used to create these bonding straps.

**Table 4-9: Bonding Strap Potential Part Numbers**

| Bonding strap part numbers |                                       |                   |                                       |
|----------------------------|---------------------------------------|-------------------|---------------------------------------|
| Braid Part Number          | Ring Terminal Part Number             | Braid Part Number | Ring Terminal Part Number             |
| QQB575*36*375              | MS25036-112 (#10) or MS25036-156 (#8) | AA59569*36*0375   | MS25036-112 (#10) or MS25036-156 (#8) |
| QQB575*34*375              | MS25036-112 (#10) or MS25036-156 (#8) | AA59569*34*0375   | MS25036-112 (#10) or MS25036-156 (#8) |

|               |                                       |                 |                                       |
|---------------|---------------------------------------|-----------------|---------------------------------------|
| QQB575*32*375 | MS25036-112 (#10) or MS25036-156 (#8) | AA59569*32*0375 | MS25036-112 (#10) or MS25036-156 (#8) |
| QQB575*30*375 | MS25036-115                           | AA59569*30*0375 | MS25036-115                           |
| QQB575*30*473 | MS25036-115                           | AA59569*36*0500 | MS25036-115                           |
| QQB575*36*500 | MS25036-115                           | AA59569*34*0500 | MS25036-115                           |
| QQB575*34*500 | MS25036-115                           | AA59569*32*0500 | MS25036-115                           |
| QQB575*32*500 | MS25036-115                           | AA59569*32*0500 | MS25036-119                           |
| QQB575*30*500 | MS25036-119                           |                 |                                       |

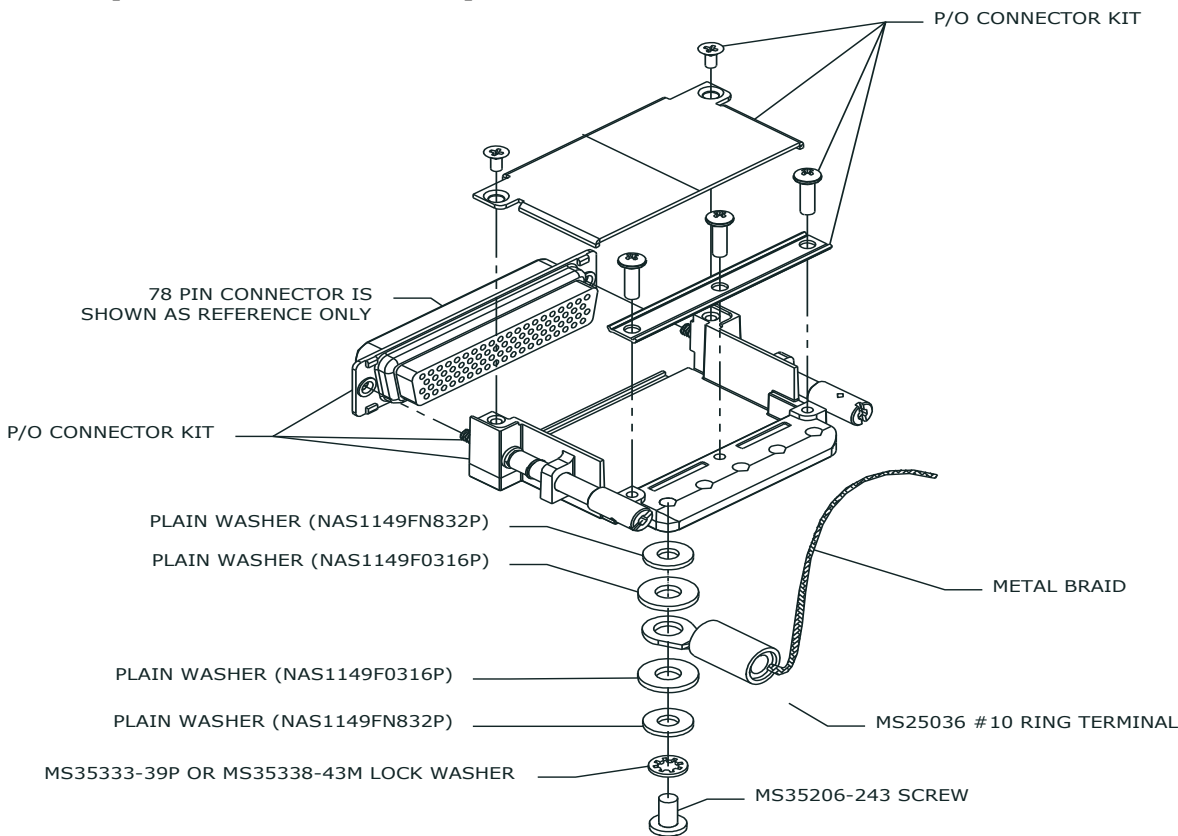


**NOTE:**

The following buildup instructions are only if the bonding strap being installed requires a #10 ring terminal for termination at a LRU backshell.

Create the bonding strap using the following instructions:

1. Cut an appropriate length of a metal braid listed in the table (maximum 10 inches)
2. Terminate both ends with the stated MS25036 terminal
3. Find a location on structure to create or re-use an existing ground stud that is size #10 for connection to this bonding strap from the LRU backshell.
4. If creating a new ground stud, create a #10 ground stud in accordance with the instructions stated in this section. Hole to be Ø0.201.
5. If using a #8 ring terminal for connection to the backshell, reference Figure 4-49 for hardware buildup using ring terminal bonding strap part numbers listed in Table 4-9.
6. If using a #10 ring terminal for connection to the backshell, use the following method to connect the #10 terminal to the LRU backshell, create the following hardware buildup as shown below in Figure 4-63.
7. Torque backshell hardware buildup to 11-17 in-lb.

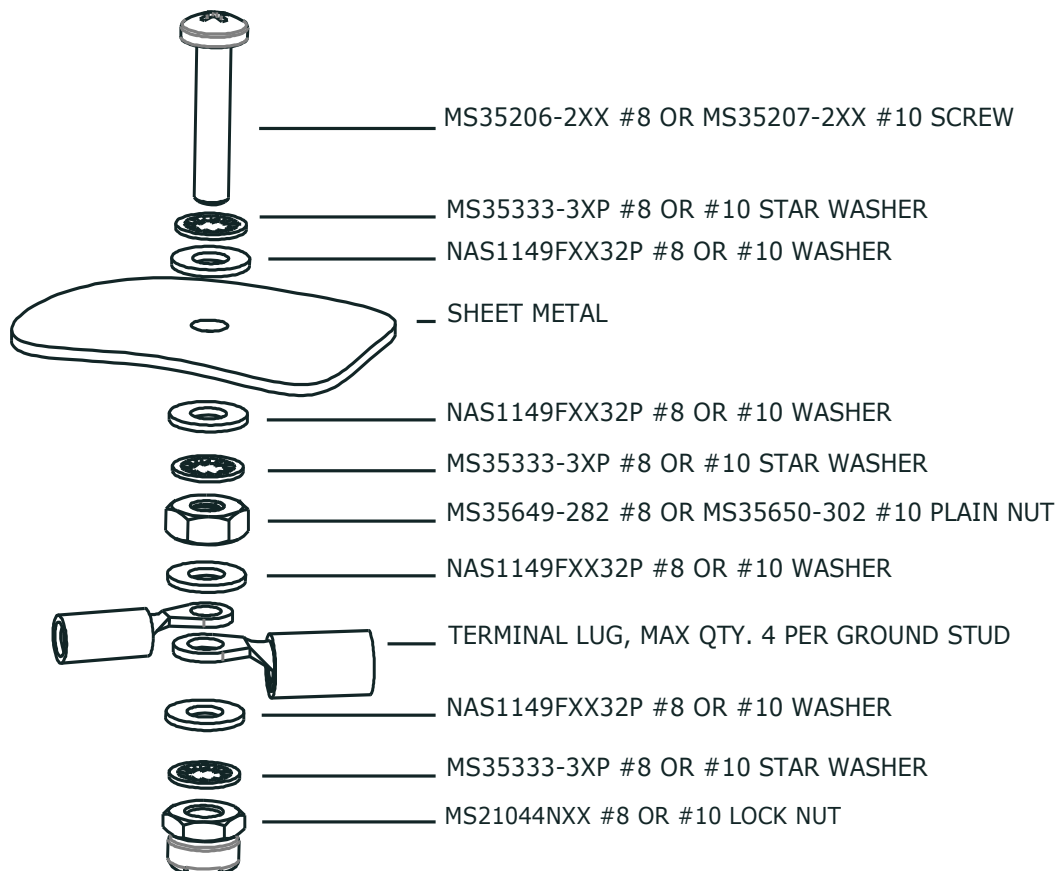


**Figure 4-63 #10 Terminal Installation on Garmin Backshell**

## 4.5.5 Ground Stud Build Up

New ground studs for equipment grounding may be required for the G5 installation. See Figure 4-64 for the parts required and the buildup sequence for ground stud installation. Clean and prepare one side of the sheet metal surface in accordance with section 4.5.

### GROUND STUD ASSY. (TYPICAL)



**Figure 4-64 - Pan Head Screw Ground Stud Buildup**

*This area intentionally blank*





## 5 SYSTEM INTERCONNECTS

This section will provide the specific wiring interconnects for the various configuration possibilities for the G5 Attitude indicator and G5 DG/HSI installations. Each installation contains the specific G5 and or GPS/VHF Navigator configuration table. Power and Ground wiring is identical for each installation and is only shown in Figure 5-2.



**NOTE:**

*The configuration tables are presented in order as the configuration pages on the G5 are presented. To make configuration of the G5 easier configure the ARINC 429 and or RS-232 options first. This allows for hidden configurations that require the ARINC 429 or RS-232 options to be selected as appropriate.*



**NOTE:**

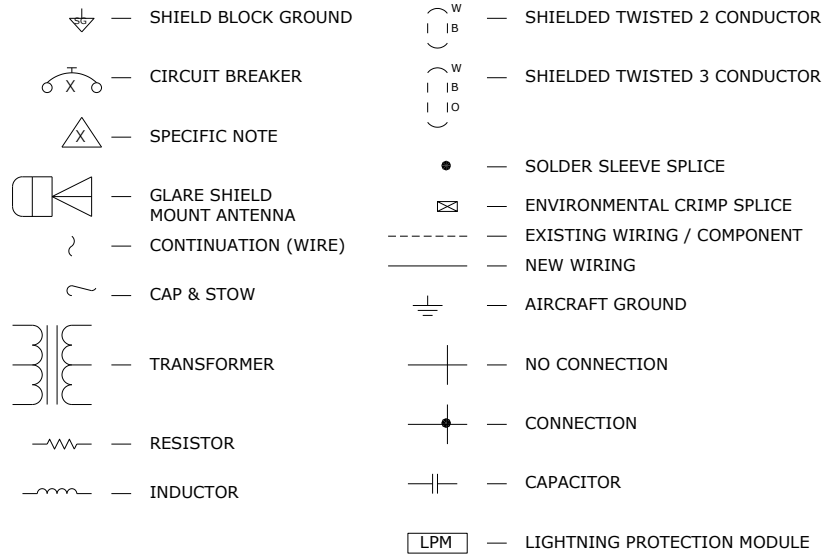
*For the interconnects diagramed in this section, all navigators are approved for interfacing with one another in a dual navigator configuration. Please refer to the specific navigator installation manual for dual unit interconnects.*

*This area intentionally blank*

## 5.1 G5 Interconnect Notes

- UNLESS OTHERWISE SPECIFIED, REFER TO SAE AS50881, REV F; WIRING AEROSPACE VEHICLE.
- UNLESS OTHERWISE SPECIFIED, ALL STRANDED WIRE IS 24 GAUGE MINIMUM AND SHALL MEET M22759/35 SPEC OR EQUIVALENT. STRANDED WIRE 22 GAUGE AND LARGER SHALL MEET M22759/34 SPEC OR EQUIVALENT. UNLESS OTHERWISE SPECIFIED, ALL SHIELDED WIRE SHALL MEET M27500 SPEC OR EQUIVALENT USING THE M22759/34 WIRE AND INSULATION TYPE.

- THE FOLLOWING SYMBOLS ARE USED ON THIS DRAWING:



- CRIMP SPLICE AS81824/1-1 IS USED FOR SINGLE 26-20 GAUGE WIRE OR UP TO QTY 2 24 GAUGE (TWISTED TOGETHER, EACH SIDE OF SPLICE).
- A SINGLE SHIELD BRAID IS TERMINATED USING AN 18-22 GAUGE TERMINAL. TWO SHIELD BRAIDS ARE TERMINATED USING A 14-16 GAUGE TERMINAL. THREE SHIELD BRAIDS ARE TERMINATED USING A 10-12 GAUGE TERMINAL.  
  
IN ALL CASES, CHOOSE THE TERMINAL THAT FITS THE MOUNTING STUD.  
  
FOR GARMIN D-SUB BACKSHELLS, NO MORE THAN TWO TERMINALS PER SCREW ARE TO BE INSTALLED.
- FOR COAXIAL CONNECTOR TERMINATION, REFER TO SPECIFIC CONNECTOR MANUFACTURER INFORMATION.
- FOR G5, GMU11, GAD29B, GAD13 CONNECTOR ASSEMBLY AND SHIELD TERMINATION INSTRUCTIONS REFERENCE FIGURES 4-49, 4-50, 4-51.
- FOR LRU'S INTERFACING TO G5 SYSTEM WIRING REFERENCE THE MANUFACTURERS INSTALLATION MANUAL FOR CONNECTOR ASSEMBLY AND SHIELD TERMINATION INSTRUCTIONS.
- LOWER-CASE LETTERS ARE DEPICTED AS UPPER-CASE LETTERS FOLLOWED BY AN ASTERISK.
- FOR SPLICES NEAR CONNECTORS, MAXIMUM LENGTH FROM SPLICE TO CONNECTOR IS THREE INCHES.
- CONFIGURATION/STRAPPING JUMPERS MAXIMUM LENGTH IS FOUR INCHES.
- CAN BUS WIRING CONNECTIONS ARE NOTED AS "CAN" ON THE DEPICTED CONNECTIONS. THESE CONNECTIONS CAN BE MADE WITH EITHER 120 OHM CAN CABLE OR M27500 TWISTED SHIELDED WIRE. SEE SECTION 3.4 FOR WIRE CHOICE GUIDANCE.
- UNLESS OTHERWISE NOTED, ALL REFERENCES TO THE GAD 29B APPLY EQUALLY TO THE GAD 29D.

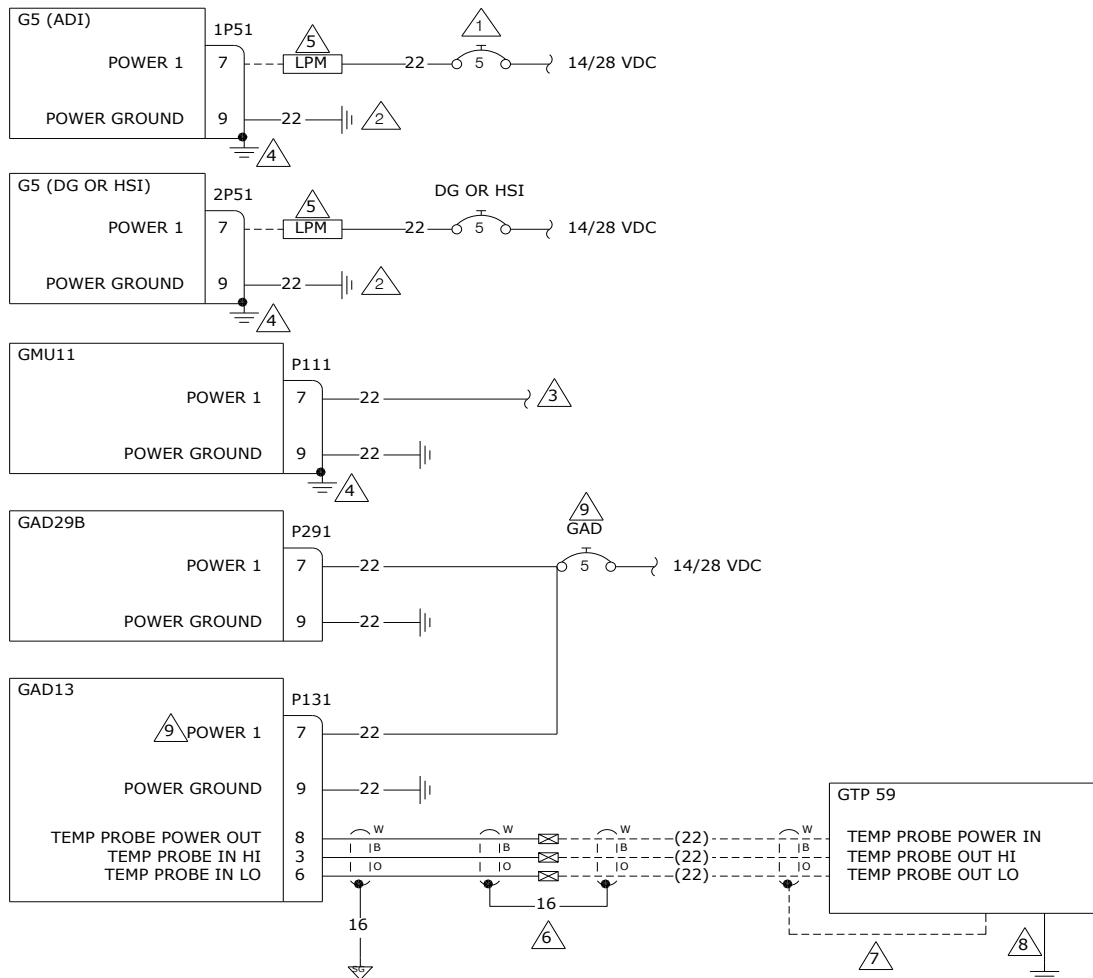
**Figure 5-1 G5 Interconnect Notes**



### CAUTION

*Check wiring connections for errors before connecting the wiring harness to the LRUs. Incorrect wiring could cause component damage.*

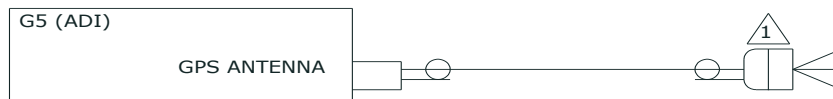
## 5.2 Power and Ground



1. CIRCUIT BREAKER MUST BE LABELED DIRECTLY ADJACENT TO THE CIRCUIT BREAKER AS "ATT" WHEN THE G5 IS INSTALLED AS THE PRIMARY ADI REGARDLESS OF THE ORIGINAL INSTRUMENT IT IS REPLACING. THE CIRCUIT BREAKER MUST BE READILY ACCESSIBLE TO THE PILOT. ALTERNATE SPELLINGS OR ABBREVIATIONS OF ADI ARE ACCEPTABLE.
2. THE G5 POWER GROUND MUST BE INDEPENDENT FROM THE POWER GROUND USED BY THE RATE OF TURN INDICATOR IF THE RATE OF TURN IS RELIANT ON ELECTRICAL POWER.
3. WHEN A G5 DG/HSI IS INSTALLED THE GMU11 MUST BE POWERED FROM THE DG/HSI CIRCUIT BREAKER. WHEN A G5 DG/HSI IS NOT INSTALLED AND A GMU11 IS INSTALLED WITH A G5 ADI THE GMU11 MUST BE POWERED FROM THE ADI CIRCUIT BREAKER. THE GMU11 AND G5 POWER WIRES MUST BE IN SEPARATE TERMINALS AT THE CIRCUIT BREAKER.
4. A BONDING STRAP NEEDS TO BE CONNECTED TO THE BACKSHELL OF THE G5 CONNECTOR TO A #10 GROUND STUD. THE GMU11 MAY NEED A BONDING STRAP CONNECTED TO ITS BACKSHELL. REFERENCE SECTION 4.5 FOR DETAILED INSTRUCTION OF THIS REQUIRED BONDING STRAP.
5. REFERENCE LIGHTNING PROTECTION MODULE (LPM) WIRING INTERFACE INTERCONNECT FOR DETAILED INSTALLATION REQUIREMENTS OF THE LPM.
6. THE GTP59 HAS A 10 FOOT LONG PRE-INSTALLED LEAD, IF THIS IS NOT LONG ENOUGH TO REACH THE GAD13 THEN CRIMP NEW WIRE TO PRE-INSTALLED LEADS AS SHOWN. EITHER WAY, THE SHIELD OF THE TWISTED SHIELDED WIRE THAT CONNECTS TO THE GAD13 BACKSHELL SHALL BE CONNECTED USING A 16 AWG WIRE.
7. THIS IS A PRE-INSTALLED GROUND LUG ON THE GTP59. PRIOR TO TIGHTENING THE GTP59 TO AIRCRAFT STRUCTURE, ENSURE THIS TERMINAL LUG IS CONNECTED TO THE HOUSING OF THE GTP59.
8. THIS GROUND CONNECTION IS MADE VIA THE STAINLESS STEEL CHASSIS OF THE GTP59. PREPARE STRUCTURE SURFACE IN ACCORDANCE WITH ARP1870 REVISION A SECTION 5 PRIOR TO FULLY TIGHTENING THE GTP59 TO THE AIRCRAFT STRUCTURE. BONDING MUST BE MEASURED TO BE LESS THAN 2.5 MILLIOHM.
9. WHEN A GAD13 IS INSTALLED WITHOUT A GAD29(B) ON THE AIRCRAFT, THE GAD13 MUST BE POWERED FROM AN INDEPENDENT 5 AMP CIRCUIT BREAKER LABELED "GAD". WHEN A GAD13 IS INSTALLED WITH A GAD29(B), THE GAD13 AND GAD29(B) MUST BE POWERED FROM THE "GAD" CIRCUIT BREAKER. THE GAD13 AND GAD29(B) POWER WIRES MUST BE IN SEPARATE TERMINALS AT THE CIRCUIT BREAKER.

**Figure 5-2 Power and Ground**

## 5.3 G5 (ADI) with a GPS Antenna



1 THE GLARE SHIELD MOUNTED GPS ANTENNA P/N 011-04036-00 REQUIRES A BNC/TNC ADAPTER P/N 330-01754-00 FOR CONNECTION TO THE G5.

Figure 5-3 G5 (ADI) with a GPS Antenna

### 5.3.1 ADI Configuration

| Config Page                                                          | Config Option                | Configuration Setting                                                                                         |
|----------------------------------------------------------------------|------------------------------|---------------------------------------------------------------------------------------------------------------|
| Device Information                                                   | Installation Type            | Certified Instrument                                                                                          |
|                                                                      | Diagnostics/Data Log         | Enabled                                                                                                       |
| Attitude Configuration                                               | Indicator Type               | Normal                                                                                                        |
|                                                                      | Pitch Display                | Normal                                                                                                        |
|                                                                      | Roll Display                 | For Fixed Type Pointers G5 Config = Ground Pointer<br>or<br>For Movable Type Pointers G5 Config = Sky Pointer |
|                                                                      | Standard Turn Roll Reference | Hide                                                                                                          |
|                                                                      | Automatic Declutter          | Enabled                                                                                                       |
| Air Data                                                             | Air Data Sensors             | Enabled                                                                                                       |
|                                                                      | Outside Air Temp Sensor      | Enabled<br><b>Note: if a GAD 13 is not installed, select Disabled</b>                                         |
|                                                                      | Vertical Speed Indicator     | (1)(2)                                                                                                        |
| Airspeed<br><br>Note: Configure Units prior to setting<br>airspeeds. | VNE                          | (1)(2)(3)                                                                                                     |
|                                                                      | VNO                          | (1)(2)(3)                                                                                                     |
|                                                                      | VSO                          | (1)(2)(3)                                                                                                     |
|                                                                      | VS1                          | (1)(2)(3)                                                                                                     |
|                                                                      | VFE                          | (1)(2)(3)                                                                                                     |
|                                                                      | VA                           | (1)(2)(3)                                                                                                     |
|                                                                      | VX                           | (1)(2)(3)                                                                                                     |
|                                                                      | VY                           | (1)(2)(3)                                                                                                     |
|                                                                      | VG                           | (1)(2)(3)                                                                                                     |
|                                                                      | VR                           | (1)(2)(3)                                                                                                     |
|                                                                      | VMC                          | (1)(2)(3)                                                                                                     |
| VYSE                                                                 | (1)(2)(3)                    |                                                                                                               |
| Magnetometer                                                         | Magnetometer                 | Disabled                                                                                                      |
| Flight Controls                                                      | Garmin Autopilot Servos      | None                                                                                                          |
|                                                                      | Analog Autopilot Interface   | None                                                                                                          |
| Backlight                                                            | Current Mode                 | Automatic                                                                                                     |
|                                                                      | Default Mode                 | Automatic                                                                                                     |
|                                                                      | Minimum Photocell Input      | Default                                                                                                       |
|                                                                      | Minimum Display Brightness   | Default                                                                                                       |
|                                                                      | Maximum Photocell Input      | Default                                                                                                       |
|                                                                      | Maximum Display Brightness   | Default                                                                                                       |
|                                                                      | Filter Time Constant         | Default                                                                                                       |
| Display                                                              | HSI Page                     | Disabled                                                                                                      |
|                                                                      | Power Up Page                | PFD                                                                                                           |
| Battery                                                              | Show Battery Status          | When Using Battery                                                                                            |
|                                                                      | Automatic Power Off          | On Ground Only                                                                                                |
| GPS                                                                  | Internal GPS Receiver        | Enabled                                                                                                       |



| Config Page                    | Config Option        | Configuration Setting |
|--------------------------------|----------------------|-----------------------|
|                                | GPS Data Field       | Show                  |
| <b>Navigation</b>              | Navigation Data      | Disable               |
|                                | Selected Course      | (4)                   |
|                                | VNAV Deviation Scale | (4)                   |
| <b>Units</b>                   | Altitude             | (1)(2)                |
|                                | Distance             | (1)(2)                |
|                                | Airspeed             | (1)(2)(3)             |
|                                | Ground Speed         | (1)(2)                |
|                                | Navigation Angle     | Magnetic              |
|                                | Vertical Speed       | (1)(2)(3)             |
|                                | Pressure             | (1)(2)                |
| <b>RS-232</b>                  | Input Format         | None                  |
|                                | Output Format        | None                  |
| <b>ARINC 429</b>               | Output 1             | None                  |
|                                | Output 2             | None                  |
|                                | Input 1              | None                  |
|                                | Input 2              | None                  |
|                                | Input 3              | None                  |
|                                | Input 4              | None                  |
| <b>Exit Configuration Mode</b> |                      |                       |

Note 1: Set configuration values and units to match the values indicated in the appropriate AFM and document settings in the space provided.

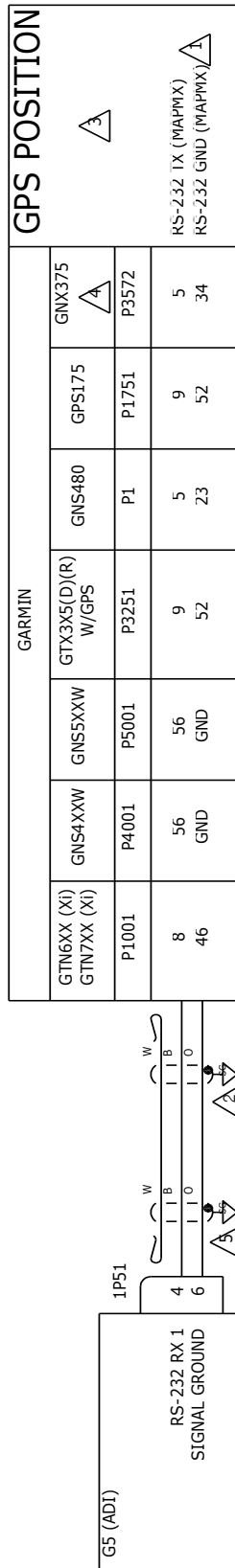
Note 2: If the aircraft has no AFM set the values as determined by the existing placards, instrument bugs or instrument markings.

Note 3: Existing placards related to airspeed limitations must be retained.

Note 4: Setting can remain at default setting, not supported in this configuration.

*This area intentionally blank*

## 5.4 G5 (ADI) with GPS Position Input



- ⚠** CONNECT TO AN APPROPRIATELY CONFIGURED, AVAILABLE RS-232 PORT. SEE CONFIGURATION TABLE BELOW FOR CONFIGURATION SETTINGS.
- ⚠** IT IS ACCEPTABLE TO SPLICE WIRES TO EXISTING WIRING OR EXISTING WIRING MAY BE RE-USED IF WIRE LENGTH IS SUFFICIENT TO REACH G5. TERMINATE SHIELD GROUNDS TO CONNECTOR BACKSHELL. SHIELD LEADS MUST BE MAX 3.0 INCHES. REFER TO UNIT INSTALLATION MANUALS FOR MORE INFORMATION.
- ⚠** IF INSTALLING WITH DUAL GPS POSITION SOURCES, G5 REQUIRES CONNECTION TO ONLY ONE GPS POSITION SOURCE. THE G5 SHALL BE CONNECTED TO THE #1 GPS POSITION SOURCE.
- ⚠** MAPXX RS-232 SHALL BE CONNECTED TO RS-232 PORT 1 OR 2 ON THE GNX375.
- ⚠** IT IS ACCEPTABLE TO SPLICE THE MAPXX RS-232 TX WIRE AND GROUND WIRE WITH ANOTHER LRU THAT REQUIRES THESE CONNECTIONS.
- ⚠** THE GLARE SHIELD MOUNTED GPS ANTENNA P/N 011-04036-00 REQUIRES A BNC/TNC ADAPTER P/N 330-01754-00 FOR CONNECTION TO THE G5.

**Figure 5-4 G5 (ADI) with GPS Position Input ADI Configuration**



## 5.4.1 ADI Configuration

| Config Page                                                       | Config Option                | Configuration Setting                                                                                         |
|-------------------------------------------------------------------|------------------------------|---------------------------------------------------------------------------------------------------------------|
| Device Information                                                | Installation Type            | Certified Instrument                                                                                          |
|                                                                   | Diagnostics/Data Log         | Enabled                                                                                                       |
| Attitude Configuration                                            | Indicator Type               | Normal                                                                                                        |
|                                                                   | Pitch Display                | Normal                                                                                                        |
|                                                                   | Roll Display                 | For Fixed Type Pointers G5 Config = Ground Pointer<br>or<br>For Movable Type Pointers G5 Config = Sky Pointer |
|                                                                   | Standard Turn Roll Reference | Hide                                                                                                          |
|                                                                   | Automatic Declutter          | Enabled                                                                                                       |
| Air Data                                                          | Air Data Sensors             | Enabled                                                                                                       |
|                                                                   | Outside Air Temp Sensor      | Enabled<br><b>Note: if a GAD 13 is not installed, select Disabled</b>                                         |
|                                                                   | Vertical Speed Indicator     | (1)(2)                                                                                                        |
| Airspeed<br><br>Note: Configure Units prior to setting airspeeds. | VNE                          | (1)(2)(3)                                                                                                     |
|                                                                   | VNO                          | (1)(2)(3)                                                                                                     |
|                                                                   | VSO                          | (1)(2)(3)                                                                                                     |
|                                                                   | VS1                          | (1)(2)(3)                                                                                                     |
|                                                                   | VFE                          | (1)(2)(3)                                                                                                     |
|                                                                   | VA                           | (1)(2)(3)                                                                                                     |
|                                                                   | VX                           | (1)(2)(3)                                                                                                     |
|                                                                   | VY                           | (1)(2)(3)                                                                                                     |
|                                                                   | VG                           | (1)(2)(3)                                                                                                     |
|                                                                   | VR                           | (1)(2)(3)                                                                                                     |
|                                                                   | VMC                          | (1)(2)(3)                                                                                                     |
| VYSE                                                              | (1)(2)(3)                    |                                                                                                               |
| Magnetometer                                                      | Magnetometer                 | Disabled                                                                                                      |
| Flight Controls                                                   | Garmin Autopilot Servos      | None                                                                                                          |
|                                                                   | Analog Autopilot Interface   | None                                                                                                          |
| Backlight                                                         | Current Mode                 | Automatic                                                                                                     |
|                                                                   | Default Mode                 | Automatic                                                                                                     |
|                                                                   | Minimum Photocell Input      | Default                                                                                                       |
|                                                                   | Minimum Display Brightness   | Default                                                                                                       |
|                                                                   | Maximum Photocell Input      | Default                                                                                                       |
|                                                                   | Maximum Display Brightness   | Default                                                                                                       |
| Display                                                           | Filter Time Constant         | Default                                                                                                       |
|                                                                   | HSI Page                     | Disabled                                                                                                      |
| Battery                                                           | Power Up Page                | PFD                                                                                                           |
|                                                                   | Show Battery Status          | When Using Battery                                                                                            |
| GPS                                                               | Automatic Power Off          | On Ground Only                                                                                                |
|                                                                   | Internal GPS Receiver        | Disabled (if G5 is not connected to GPS antenna)<br>Enabled (if G5 is connected to GPS antenna)               |
| Navigation                                                        | Show Data Fields             | Show                                                                                                          |
|                                                                   | Navigation Data              | Disabled                                                                                                      |
|                                                                   | Selected Course              | (4)                                                                                                           |
| Units                                                             | VNAV Deviation Scale         | (4)                                                                                                           |
|                                                                   | Altitude                     | (1)(2)                                                                                                        |
|                                                                   | Distance                     | (1)(2)                                                                                                        |
|                                                                   | Airspeed                     | (1)(2)(3)                                                                                                     |
|                                                                   | Ground Speed                 | (1)(2)                                                                                                        |
|                                                                   | Navigation Angle             | Magnetic                                                                                                      |
|                                                                   | Vertical Speed               | (1)(2)                                                                                                        |
| Pressure                                                          | (1)(2)                       |                                                                                                               |



| Config Page             | Config Option | Configuration Setting |
|-------------------------|---------------|-----------------------|
| RS-232                  | Input Format  | MapMx                 |
|                         | Output Format | None                  |
| ARINC 429               | Output 1      | None                  |
|                         | Output 2      | None                  |
|                         | Input 1       | None                  |
|                         | Input 2       | None                  |
|                         | Input 3       | None                  |
|                         | Input 4       | None                  |
| Exit Configuration Mode |               |                       |

#### 5.4.2 GTN 6XX/7XX (Xi) Configuration

| Config Page | Config Option                                          | Configuration Setting   |
|-------------|--------------------------------------------------------|-------------------------|
| RS-232      | RS-232 (x)<br>(x represents any available RS-232 Port) | Output = MapMX Format 1 |

#### 5.4.3 GNS 4XXW/5XXW Configuration

| Config Page            | Config Option                                             | Configuration Setting         |
|------------------------|-----------------------------------------------------------|-------------------------------|
| MAIN RS232 CONFIG Page | RS-232 (x)<br>(x represents any available RS-232 Channel) | Input = OFF<br>Output = MapMX |

#### 5.4.4 GNS 480 Configuration

| Config Page            | Config Option                                         | Configuration Setting |
|------------------------|-------------------------------------------------------|-----------------------|
| GND Maint Serial Setup | CH (x)<br>(x represents any available Serial Channel) | Output = MapMX        |

#### 5.4.5 GTX 3X5(D)(R) Configuration

| Config Page     | Config Option                                             | Configuration Setting |
|-----------------|-----------------------------------------------------------|-----------------------|
| Interface Group | RS-232 (x)<br>(x represents any available RS-232 Channel) | Output = MapMX        |

#### 5.4.6 GPS 175 Configuration

| Config Page                   | Config Option                                        | Configuration Setting |
|-------------------------------|------------------------------------------------------|-----------------------|
| Interfaced Equipment – RS 232 | Port (x)<br>(x represents any available RS-232 Port) | MapMX                 |

#### 5.4.7 GNX 375 Configuration

| Config Page         | Config Option                                 | Configuration Setting |
|---------------------|-----------------------------------------------|-----------------------|
| Interfaces – RS-232 | Port (x)<br>(x represents RS-232 Port 1 or 2) | MapMX (Format 1)      |





Note 1: Set configuration values and units to match the values indicated in the appropriate AFM and document settings in the space provided.

Note 2: If the aircraft has no AFM set the values as determined by the existing placards, instrument bugs or instrument markings.

Note 3: Existing placards related to airspeed limitations must be retained.

Note 4: Setting can remain at default setting, not supported in this configuration.

*This area intentionally blank*

## 5.5 G5 (ADI) and GMU 11 with GPS Position Input

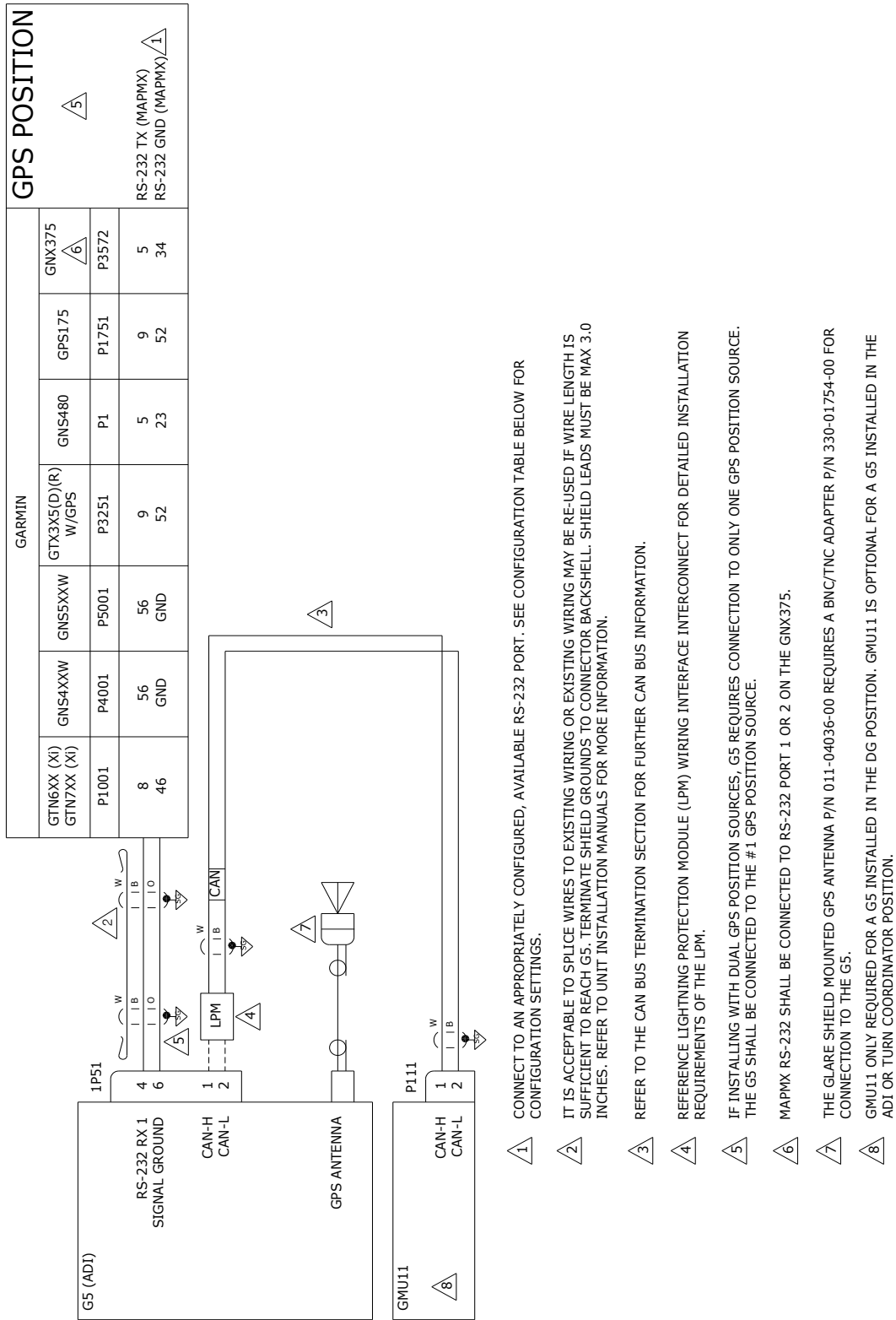


Figure 5-5 G5 (ADI) and GMU 11 with GPS Position Input



## 5.5.1 ADI Configuration

| Config Page                                                       | Config Option                | Configuration Setting                                                                                         |
|-------------------------------------------------------------------|------------------------------|---------------------------------------------------------------------------------------------------------------|
| Device Information                                                | Installation Type            | Certified Instrument                                                                                          |
|                                                                   | Diagnostics/Data Log         | Enabled                                                                                                       |
| Attitude Configuration                                            | Indicator Type               | Normal                                                                                                        |
|                                                                   | Pitch Display                | Normal                                                                                                        |
|                                                                   | Roll Display                 | For Fixed Type Pointers G5 Config = Ground Pointer<br>or<br>For Movable Type Pointers G5 Config = Sky Pointer |
|                                                                   | Standard Turn Roll Reference | Hide                                                                                                          |
|                                                                   | Automatic Declutter          | Enabled                                                                                                       |
| Air Data                                                          | Air Data Sensors             | Enabled                                                                                                       |
|                                                                   | Outside Air Temp Sensor      | Enabled<br><b>Note: if a GAD 13 is not installed, select Disabled</b>                                         |
|                                                                   | Vertical Speed Indicator     | (1)(2)                                                                                                        |
| Airspeed<br><br>Note: Configure Units prior to setting airspeeds. | VNE                          | (1)(2)(3)                                                                                                     |
|                                                                   | VNO                          | (1)(2)(3)                                                                                                     |
|                                                                   | VSO                          | (1)(2)(3)                                                                                                     |
|                                                                   | VS1                          | (1)(2)(3)                                                                                                     |
|                                                                   | VFE                          | (1)(2)(3)                                                                                                     |
|                                                                   | VA                           | (1)(2)(3)                                                                                                     |
|                                                                   | VX                           | (1)(2)(3)                                                                                                     |
|                                                                   | VY                           | (1)(2)(3)                                                                                                     |
|                                                                   | VG                           | (1)(2)(3)                                                                                                     |
|                                                                   | VR                           | (1)(2)(3)                                                                                                     |
|                                                                   | VMC                          | (1)(2)(3)                                                                                                     |
| VYSE                                                              | (1)(2)(3)                    |                                                                                                               |
| Magnetometer                                                      | Magnetometer                 | Enabled (if GMU 11 is connected)<br>Disabled (if GMU 11 is not connected)                                     |
|                                                                   | Orientation                  | Connector Aft<br>Or<br>Connector Forward<br>Or<br>Connector Port<br>Or<br>Connector Starboard                 |
| Flight Controls                                                   | Garmin Autopilot Servos      | None                                                                                                          |
|                                                                   | Analog Autopilot Interface   | None                                                                                                          |
| Backlight                                                         | Current Mode                 | Automatic                                                                                                     |
|                                                                   | Default Mode                 | Automatic                                                                                                     |
|                                                                   | Minimum Photocell Input      | Default                                                                                                       |
|                                                                   | Minimum Display Brightness   | Default                                                                                                       |
|                                                                   | Maximum Photocell Input      | Default                                                                                                       |
|                                                                   | Maximum Display Brightness   | Default                                                                                                       |
|                                                                   | Filter Time Constant         | Default                                                                                                       |
| Display                                                           | HSI Page                     | Disabled                                                                                                      |
|                                                                   | Power Up Page                | PFD                                                                                                           |
| Battery                                                           | Show Battery Status          | When Using Battery                                                                                            |
|                                                                   | Automatic Power Off          | On Ground Only                                                                                                |
| GPS                                                               | Internal GPS Receiver        | Disabled (if G5 is not connected to GPS antenna)<br>Enabled (if G5 is connected to GPS antenna)               |
|                                                                   | Show Data Fields             | Show                                                                                                          |
| Navigation                                                        | Navigation Data              | Disabled                                                                                                      |
|                                                                   | Selected Course              | (4)                                                                                                           |
|                                                                   | VNAV Deviation Scale         | (4)                                                                                                           |



| Config Page                    | Config Option    | Configuration Setting |
|--------------------------------|------------------|-----------------------|
| <b>Units</b>                   | Altitude         | (1)(2)                |
|                                | Distance         | (1)(2)                |
|                                | Airspeed         | (1)(2)(3)             |
|                                | Ground Speed     | (1)(2)                |
|                                | Navigation Angle | Magnetic              |
|                                | Vertical Speed   | (1)(2)                |
|                                | Pressure         | (1)(2)                |
| <b>RS-232</b>                  | Input Format     | MapMx                 |
|                                | Output Format    | None                  |
| <b>ARINC 429</b>               | Output 1         | None                  |
|                                | Output 2         | None                  |
|                                | Input 1          | None                  |
|                                | Input 2          | None                  |
|                                | Input 3          | None                  |
|                                | Input 4          | None                  |
| <b>Exit Configuration Mode</b> |                  |                       |

### 5.5.2 GTN 6XX/7XX (Xi) Configuration

| Config Page   | Config Option                                          | Configuration Setting   |
|---------------|--------------------------------------------------------|-------------------------|
| <b>RS-232</b> | RS-232 (x)<br>(x represents any available RS-232 Port) | Output = MapMX Format 1 |

### 5.5.3 GNS 4XXW/5XXW Configuration

| Config Page                   | Config Option                                             | Configuration Setting         |
|-------------------------------|-----------------------------------------------------------|-------------------------------|
| <b>MAIN RS232 CONFIG Page</b> | RS-232 (x)<br>(x represents any available RS-232 Channel) | Input = OFF<br>Output = MapMX |

### 5.5.4 GNS 480 Configuration

| Config Page                   | Config Option                                         | Configuration Setting |
|-------------------------------|-------------------------------------------------------|-----------------------|
| <b>GND Maint Serial Setup</b> | CH (x)<br>(x represents any available Serial Channel) | Output = MapMX        |

### 5.5.5 GTX 3X5 (D)(R) Configuration

| Config Page            | Config Option                                             | Configuration Setting |
|------------------------|-----------------------------------------------------------|-----------------------|
| <b>Interface Group</b> | RS-232 (x)<br>(x represents any available RS-232 Channel) | Output = MapMX        |

### 5.5.6 GPS 175 Configuration

| Config Page                          | Config Option                                        | Configuration Setting |
|--------------------------------------|------------------------------------------------------|-----------------------|
| <b>Interfaced Equipment – RS 232</b> | Port (x)<br>(x represents any available RS-232 Port) | MapMX                 |



### 5.5.7 GNX 375 Configuration

| Config Page         | Config Option                                 | Configuration Setting |
|---------------------|-----------------------------------------------|-----------------------|
| Interfaces – RS-232 | Port (x)<br>(x represents RS-232 Port 1 or 2) | MapMX (Format 1)      |

Note 1: Set configuration values and units to match the values indicated in the appropriate AFM and document settings in the space provided.

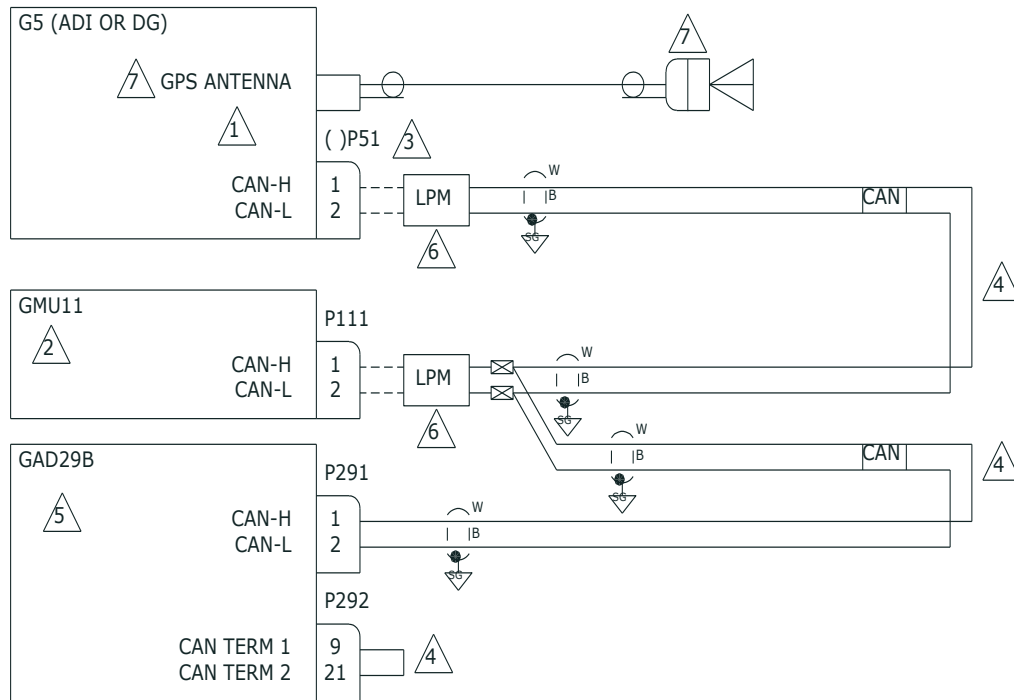
Note 2: If the aircraft has no AFM set the values as determined by the existing placards, instrument bugs or instrument markings.

Note 3: Existing placards related to airspeed limitations must be retained.

Note 4: Setting can remain at default setting, not supported in this configuration.

*This area intentionally blank*

## 5.6 G5 (ADI or DG), GMU 11 and GPS Antenna



- 1 GPS ANTENNA IS ONLY REQUIRED FOR A G5 IN THE ADI OR TURN COORDINATOR POSITION. GPS ANTENNA IS OPTIONAL FOR A G5 IN THE DG POSITION.
- 2 GMU11 ONLY REQUIRED FOR A G5 INSTALLED IN THE DG POSITION. GMU11 IS OPTIONAL FOR A G5 INSTALLED IN THE ADI OR TURN COORDINATOR POSITION.
- 3 LABEL CONNECTOR "1P51" FOR A G5 IN THE ADI OR TURN COORDINATOR POSITION. LABEL CONNECTOR "2P51" FOR A G5 IN THE DG POSITION.
- 4 CAN BUS LRUS MAY BE IN ANY ORDER ALONG BACKBONE AS LONG AS CAN BUS BACKBONE STRUCTURE GUIDELINES ARE FOLLOWED. REFER TO THE CAN BUS TERMINATION SECTION FOR FURTHER CAN BUS INFORMATION.
- 5 GAD29B IS INSTALLED WHEN INTERFACING TO AN AUTOPILOT. FOR NON-GARMIN AUTOPILOT INTERCONNECTS, SEE GAD29B INTERFACE TO A NON-GARMIN AUTOPILOT INTERCONNECT DIAGRAMS FOR FURTHER INFORMATION.
- 6 REFERENCE LIGHTNING PROTECTION MODULE (LPM) WIRING INTERFACE INTERCONNECT FOR DETAILED INSTALLATION REQUIREMENTS OF THE LPM.
- 7 THE GLARE SHIELD MOUNTED GPS ANTENNA P/N 011-04036-00 REQUIRES A BNC/TNC ADAPTER P/N 330-01754-00 FOR CONNECTION TO THE G5.

**Figure 5-6 G5 (ADI or DG), GMU 11 and GPS Antenna**

### 5.6.1 ADI or DG Configuration

| Config Page            | Config Option        | Configuration Setting                              |
|------------------------|----------------------|----------------------------------------------------|
| Device Information     | Installation Type    | Certified Instrument                               |
|                        | Diagnostics/Data Log | Enabled                                            |
| Attitude Configuration | Indicator Type       | Normal                                             |
|                        | Pitch Display        | Normal                                             |
|                        | Roll Display         | For Fixed Type Pointers G5 Config = Ground Pointer |



| Config Page                                              | Config Option                | Configuration Setting                                                                                                                                            |
|----------------------------------------------------------|------------------------------|------------------------------------------------------------------------------------------------------------------------------------------------------------------|
|                                                          |                              | or<br>For Movable Type Pointers G5 Config = Sky Pointer                                                                                                          |
|                                                          | Standard Turn Roll Reference | Hide                                                                                                                                                             |
|                                                          | Automatic Declutter          | Enabled                                                                                                                                                          |
| <b>Air Data</b>                                          | Air Data Sensors             | Enabled                                                                                                                                                          |
|                                                          | Outside Air Temp Sensor      | Enabled                                                                                                                                                          |
|                                                          | Vertical Speed Indicator     | <b>Note: if a GAD 13 is not installed, select Disabled</b><br>(1)(2)                                                                                             |
| <b>Airspeed</b>                                          | VNE                          | (1)(2)(3)                                                                                                                                                        |
| <b>Note: Configure Units prior to setting airspeeds.</b> | VNO                          | (1)(2)(3)                                                                                                                                                        |
|                                                          | VSO                          | (1)(2)(3)                                                                                                                                                        |
|                                                          | VS1                          | (1)(2)(3)                                                                                                                                                        |
|                                                          | VFE                          | (1)(2)(3)                                                                                                                                                        |
|                                                          | VA                           | (1)(2)(3)                                                                                                                                                        |
|                                                          | VX                           | (1)(2)(3)                                                                                                                                                        |
|                                                          | VY                           | (1)(2)(3)                                                                                                                                                        |
|                                                          | VG                           | (1)(2)(3)                                                                                                                                                        |
|                                                          | VR                           | (1)(2)(3)                                                                                                                                                        |
|                                                          | VMC                          | (1)(2)(3)                                                                                                                                                        |
|                                                          | VYSE                         | (1)(2)(3)                                                                                                                                                        |
| <b>Magnetometer</b>                                      | Magnetometer                 | Enabled (if GMU 11 is connected)<br>Disabled (if GMU 11 is not connected)                                                                                        |
|                                                          | Orientation                  | Connector Aft<br>Or<br>Connector Forward<br>Or<br>Connector Port<br>Or<br>Connector Starboard                                                                    |
| <b>Flight Controls</b>                                   | Garmin Autopilot Servos      | None                                                                                                                                                             |
|                                                          | Analog Autopilot Interface   | None<br>Or<br>See Section 5.24 if a Non-Garmin Autopilot is interfaced                                                                                           |
| <b>Backlight</b>                                         | Current Mode                 | Automatic                                                                                                                                                        |
|                                                          | Default Mode                 | Automatic                                                                                                                                                        |
|                                                          | Minimum Photocell Input      | Default                                                                                                                                                          |
|                                                          | Minimum Display Brightness   | Default                                                                                                                                                          |
|                                                          | Maximum Photocell Input      | Default                                                                                                                                                          |
|                                                          | Maximum Display Brightness   | Default                                                                                                                                                          |
|                                                          | Filter Time Constant         | Default                                                                                                                                                          |
| <b>Display (When used as an ADI or Turn Coord)</b>       | HSI Page                     | Disabled                                                                                                                                                         |
|                                                          | Power Up Page                | PFD                                                                                                                                                              |
| <b>Display (When used as a DG)</b>                       | HSI Page                     | Enabled                                                                                                                                                          |
|                                                          | Power Up Page                | HSI                                                                                                                                                              |
| <b>Battery</b>                                           | Show Battery Status          | When Using Battery                                                                                                                                               |
|                                                          | Automatic Power Off          | On Ground Only                                                                                                                                                   |
| <b>GPS</b>                                               | Internal GPS Receiver        | Enabled                                                                                                                                                          |
|                                                          | GPS Data Fields              | Show                                                                                                                                                             |
| <b>Navigation</b>                                        | Navigation Data              | Disabled<br><b>Note: Only used if an autopilot is configured. If an autopilot interface is configured, this configuration page is set to ENABLED by default.</b> |
|                                                          | Selected Course              | (4)                                                                                                                                                              |
|                                                          | VNAV Deviation Scale         | (4)                                                                                                                                                              |
| <b>Units</b>                                             | Altitude                     | (1)(2)                                                                                                                                                           |
|                                                          | Distance                     | (1)(2)                                                                                                                                                           |



| Config Page                    | Config Option    | Configuration Setting |
|--------------------------------|------------------|-----------------------|
|                                | Airspeed         | (1)(2)(3)             |
|                                | Ground Speed     | (1)(2)                |
|                                | Navigation Angle | Magnetic              |
|                                | Vertical Speed   | (1)(2)                |
|                                | Pressure         | (1)(2)                |
| <b>RS-232</b>                  |                  |                       |
|                                | Input Format     | None                  |
|                                | Output Format    | None                  |
| <b>ARINC 429</b>               |                  |                       |
|                                | Output 1         | None                  |
|                                | Output 2         | None                  |
|                                | Input 1          | None                  |
|                                | Input 2          | None                  |
|                                | Input 3          | None                  |
|                                | Input 4          | None                  |
| <b>Exit Configuration Mode</b> |                  |                       |

Note 1: Set configuration values and units to match the values indicated in the appropriate AFM and document settings in the space provided.

Note 2: If the aircraft has no AFM set the values as determined by the existing placards, instrument bugs or instrument markings.

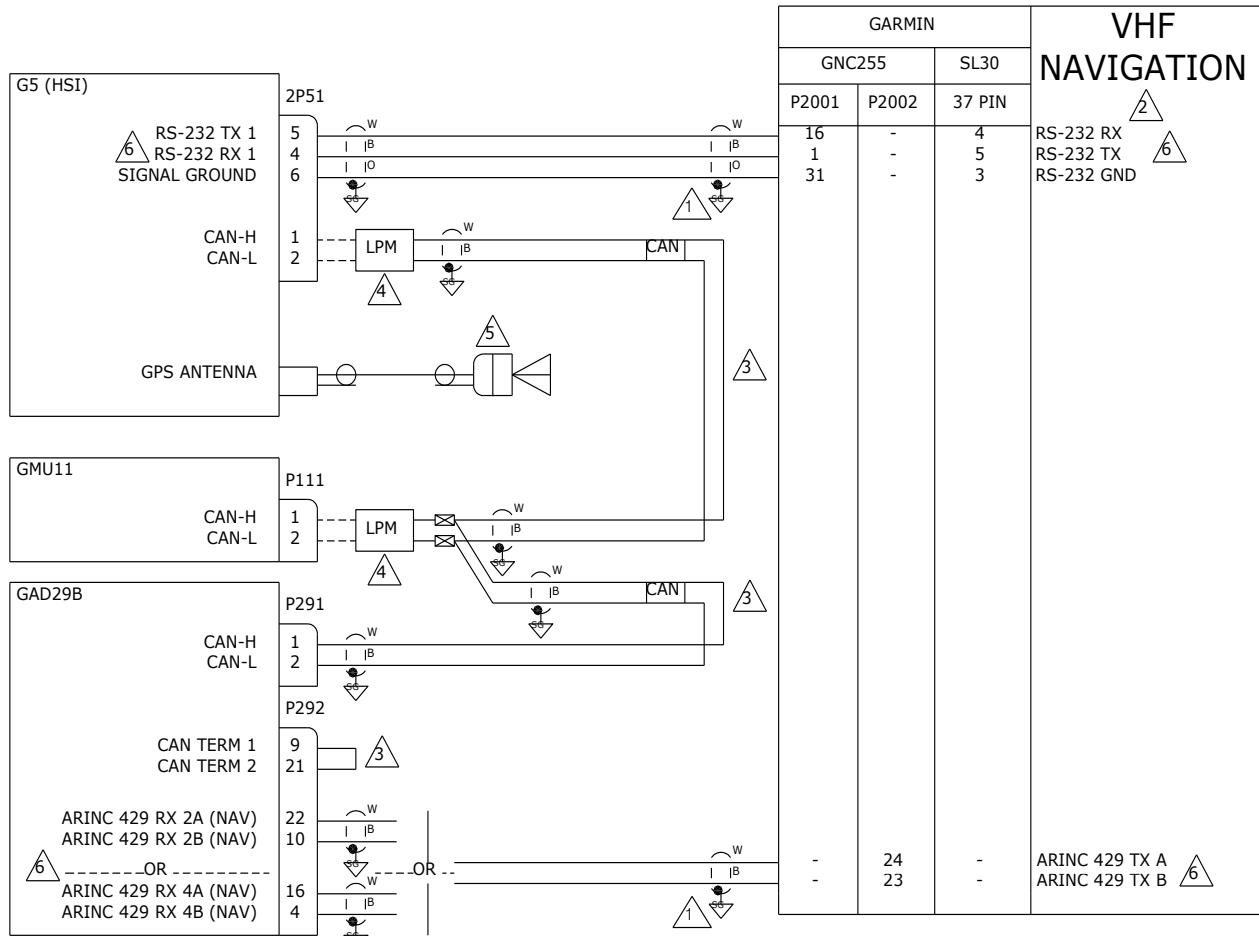
Note 3: Existing placards related to airspeed limitations must be retained.

Note 4: Setting can remain at default setting, not supported in this configuration.

*This area intentionally blank*



## 5.7 G5 (HSI) with VHF Navigator



- 1 IT IS ACCEPTABLE TO SPLICE WIRES TO EXISTING WIRING OR EXISTING WIRING MAY BE RE-USED IF WIRE LENGTH IS SUFFICIENT TO REACH G5/GAD29B. TERMINATE SHIELD GROUNDS TO CONNECTOR BACKSHELL. SHIELD LEADS MUST BE MAX 3.0 INCHES. REFER TO UNIT INSTALLATION MANUALS FOR MORE INFORMATION.
- 2 THIS STC DOES NOT APPROVE A CDI INTERFACED WITH THE SAME NAVIGATOR AS THE G5. REMOVE ANY EXISTING CDI INTERFACED WITH THIS NAVIGATOR.
- 3 CAN BUS LRUS MAY BE IN ANY ORDER ALONG BACKBONE AS LONG AS CAN BUS BACKBONE STRUCTURE GUIDELINES ARE FOLLOWED. REFER TO THE CAN BUS TERMINATION SECTION FOR FURTHER CAN BUS INFORMATION.
- 4 REFERENCE LIGHTNING PROTECTION MODULE (LPM) WIRING INTERFACE INTERCONNECT FOR DETAILED INSTALLATION REQUIREMENTS OF THE LPM.
- 5 THE GLARE SHIELD MOUNTED GPS ANTENNA P/N 011-04036-00 REQUIRES A BNC/TNC ADAPTER P/N 330-01754-00 FOR CONNECTION TO THE G5.
- 6 IF INTERFACED WITH DUAL NAVIGATORS, CONNECT THE G5 RS-232 TO THE #1 NAVIGATOR. CONNECT THE #2 NAVIGATOR VIA ARINC 429 CONNECTIONS, IF AVAILABLE. THE #2 NAVIGATOR SHALL NOT BE CONNECTED TO THE G5 VIA RS-232. SEE CONFIGURATION TABLE FOR APPLICABLE CONFIGURATION SETTINGS.

**Figure 5-7 G5 (HSI) with VHF Navigator**



## 5.7.1 HSI Configuration

| Config Page                                                       | Config Option                | Configuration Setting                                                                                         |
|-------------------------------------------------------------------|------------------------------|---------------------------------------------------------------------------------------------------------------|
| Device Information                                                | Installation Type            | Certified Instrument                                                                                          |
|                                                                   | Diagnostics/Data Log         | Enabled                                                                                                       |
| Attitude Configuration                                            | Indicator Type               | Normal                                                                                                        |
|                                                                   | Pitch Display                | Normal                                                                                                        |
|                                                                   | Roll Display                 | For Fixed Type Pointers G5 Config = Ground Pointer<br>or<br>For Movable Type Pointers G5 Config = Sky Pointer |
|                                                                   | Standard Turn Roll Reference | Hide                                                                                                          |
|                                                                   | Automatic Declutter          | Disabled                                                                                                      |
| Air Data                                                          | Air Data Sensors             | Enabled                                                                                                       |
|                                                                   | Outside Air Temp Sensor      | Enabled<br><b>Note: if a GAD 13 is not installed, select Disabled</b>                                         |
|                                                                   | Vertical Speed Indicator     | (1)(2)                                                                                                        |
| Airspeed<br><br>Note: Configure Units prior to setting airspeeds. | VNE                          | (1)(2)(3)                                                                                                     |
|                                                                   | VNO                          | (1)(2)(3)                                                                                                     |
|                                                                   | VSO                          | (1)(2)(3)                                                                                                     |
|                                                                   | VS1                          | (1)(2)(3)                                                                                                     |
|                                                                   | VFE                          | (1)(2)(3)                                                                                                     |
|                                                                   | VA                           | (1)(2)(3)                                                                                                     |
|                                                                   | VX                           | (1)(2)(3)                                                                                                     |
|                                                                   | VY                           | (1)(2)(3)                                                                                                     |
|                                                                   | VG                           | (1)(2)(3)                                                                                                     |
|                                                                   | VR                           | (1)(2)(3)                                                                                                     |
|                                                                   | VMC                          | (1)(2)(3)                                                                                                     |
| VYSE                                                              | (1)(2)(3)                    |                                                                                                               |
| Magnetometer                                                      | Magnetometer                 | Enabled                                                                                                       |
|                                                                   | Orientation                  | Connector Aft<br>Or<br>Connector Forward<br>Or<br>Connector Port<br>Or<br>Connector Starboard                 |
| Flight Controls                                                   | Garmin Autopilot Servos      | None                                                                                                          |
|                                                                   | Analog Autopilot Interface   | None<br>Or<br>See Section 5.24 if a Non-Garmin Autopilot is interfaced                                        |
| Backlight                                                         | Current Mode                 | Automatic                                                                                                     |
|                                                                   | Default Mode                 | Automatic                                                                                                     |
|                                                                   | Minimum Photocell Input      | Default                                                                                                       |
|                                                                   | Minimum Display Brightness   | Default                                                                                                       |
|                                                                   | Maximum Photocell Input      | Default                                                                                                       |
|                                                                   | Maximum Display Brightness   | Default                                                                                                       |
|                                                                   | Filter Time Constant         | Default                                                                                                       |
| Display                                                           | HSI Page                     | Enabled                                                                                                       |
|                                                                   | Power Up Page                | HSI                                                                                                           |
| Battery                                                           | Show Battery Status          | When Using Battery                                                                                            |
|                                                                   | Automatic Power Off          | On Ground Only                                                                                                |
| GPS                                                               | Internal GPS Receiver        | Enabled                                                                                                       |
|                                                                   | GPS Data Fields              | Show                                                                                                          |



| Config Page             | Config Option        | Configuration Setting                                                                                                  |
|-------------------------|----------------------|------------------------------------------------------------------------------------------------------------------------|
| Navigation              | Navigation Data      | Enabled<br><b>Note: If an autopilot interface is configured, this configuration page is set to ENABLED by default.</b> |
|                         | Selected Course      | Enabled (5)                                                                                                            |
|                         | Selected Course 1    | Enabled (6)                                                                                                            |
|                         | Selected Course 2    | Enabled (6)                                                                                                            |
|                         | VNAV Deviation Scale | (4)                                                                                                                    |
| Units                   | Altitude             | (1)(2)                                                                                                                 |
|                         | Distance             | (1)(2)                                                                                                                 |
|                         | Airspeed             | (1)(2)(3)                                                                                                              |
|                         | Vertical Speed       | (1)(2)                                                                                                                 |
|                         | Pressure             | (1)(2)                                                                                                                 |
| RS-232                  | Input Format         | Garmin VHF NAV Radio (If GNC is #1 Navigator)                                                                          |
|                         | Output Format        | Garmin VHF NAV Radio (If GNC is #1 Navigator)                                                                          |
| ARINC 429               | Output 1             | None                                                                                                                   |
|                         | Output 2             | None                                                                                                                   |
|                         | Input 1              | None                                                                                                                   |
|                         | Input 2              | Garmin VOR/ILS (SDI 1) (If GNC is #1 Navigator)                                                                        |
|                         | Input 3              | None                                                                                                                   |
|                         | Input 4              | Garmin VOR/ILS (SDI 2) (If GNC is #2 Navigator)                                                                        |
| Exit Configuration Mode |                      |                                                                                                                        |

### 5.7.2 GNC 255 Configuration

| Config Page       | Config Option      | Configuration Setting                                                                               |
|-------------------|--------------------|-----------------------------------------------------------------------------------------------------|
| Sys Configuration | RS 232 Serial Port | IO Mode = NMEA                                                                                      |
| NAV Configuration | CDI Indicator      | Serial (If GNC is #1 navigator)<br>Or<br>None (If GNC is #2 navigator)                              |
|                   | ARINC 429          | Tx = Low<br>SDI =<br>VOR/ILS 1 (If GNC is #1 Navigator)<br>Or<br>VOR/ILS 2 (If GNC is #2 Navigator) |

### 5.7.3 SL30 Configuration

| Config Page            | Config Option      | Configuration Setting |
|------------------------|--------------------|-----------------------|
| Sys Configuration      | RS 232 Serial Port | No Setting            |
| Attitude Configuration | Indicator Type     | TYPE = Serial         |

Note 1: Set configuration values and units to match the values indicated in the appropriate AFM and document settings in the space provided.

Note 2: If the aircraft has no AFM set the values as determined by the existing placards, instrument bugs or instrument markings.

Note 3: Existing placards related to airspeed limitations must be retained.

Note 4: Setting can remain at default setting, not supported in this configuration.

Note 5: The “Selected Course” will display when only one navigator is interfaced to the G5.

Note 6: “Selected Course 1” and “Selected Course 2” will display when dual navigators are interfaced.

## 5.8 G5 (HSI) with GPS/VHF Navigator

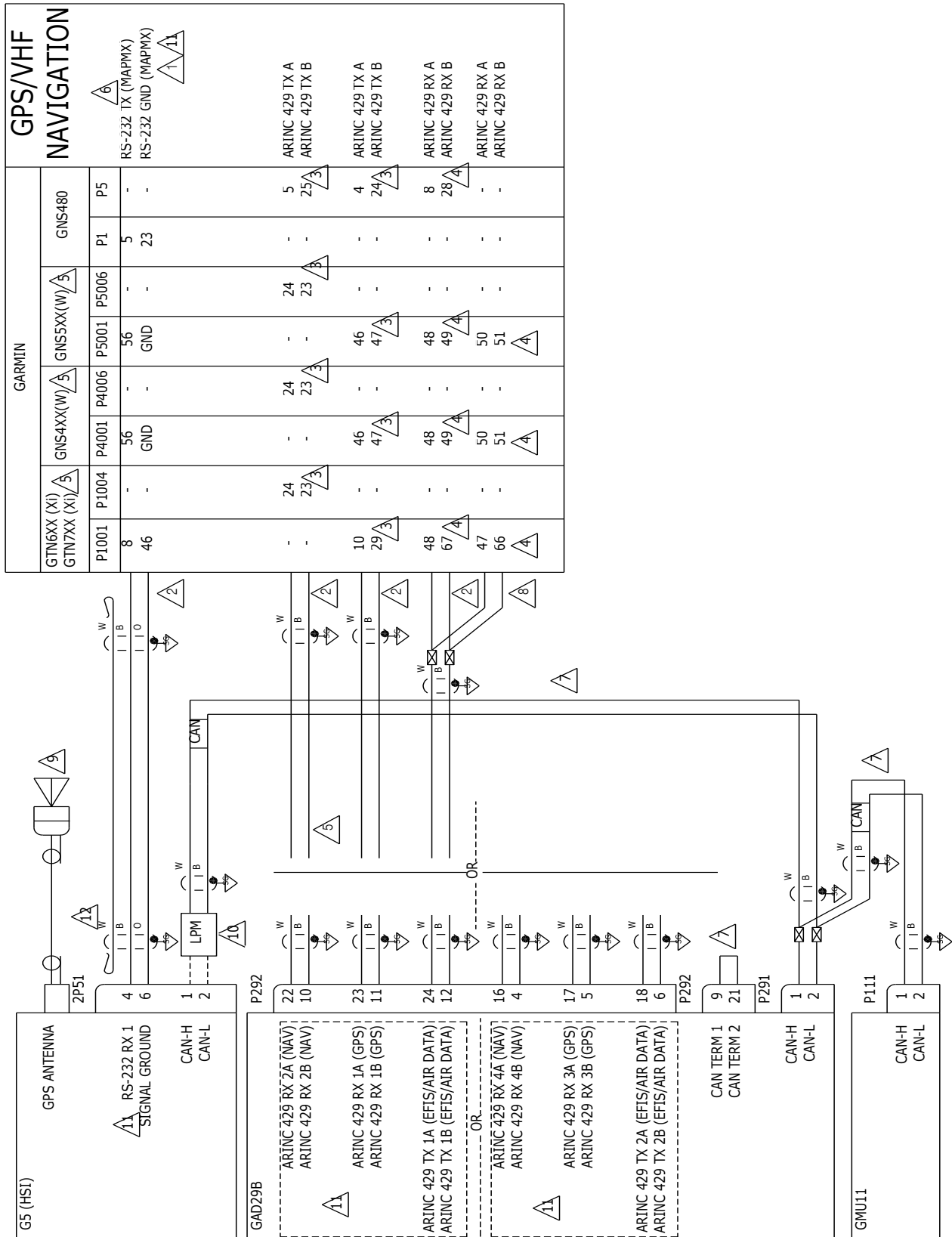


Figure 5-8 G5 (HSI) with GPS/VHF Navigator



1. CONNECT TO AN APPROPRIATELY CONFIGURED, AVAILABLE RS-232 PORT.
2. IT IS ACCEPTABLE TO SPLICE WIRES TO EXISTING WIRING OR EXISTING WIRING MAY BE RE-USED IF WIRE LENGTH IS SUFFICIENT TO REACH G5/GAD29B. TERMINATE SHIELD GROUNDS TO CONNECTOR BACKSHELL. SHIELD LEADS MUST BE MAX 3.0 INCHES. REFER TO UNIT INSTALLATION MANUALS FOR MORE INFORMATION.
3. CONNECT TO ANY APPROPRIATELY CONFIGURED, AVAILABLE ARINC 429 TX PORT.
4. CONNECT TO ANY APPROPRIATELY CONFIGURED, AVAILABLE ARINC 429 RX PORT.
5. ARINC 429 TX (NAV) CONNECTION NOT APPLICABLE WHEN INTERFACING WITH GTN625/725 UNITS OR GNS4XX(W)/5XX(W) UNITS WITHOUT VHF NAVIGATION.
6. THIS STC DOES NOT APPROVE A CDI INTERFACED WITH THE SAME NAVIGATOR AS THE G5. REMOVE ANY EXISTING CDI INTERFACED WITH THIS NAVIGATOR.
7. CAN BUS LRUS MAY BE IN ANY ORDER ALONG BACKBONE AS LONG AS CAN BUS BACKBONE STRUCTURE GUIDELINES ARE FOLLOWED. REFER TO THE CAN BUS TERMINATION SECTION FOR FURTHER CAN BUS INFORMATION.
8. CONNECTION ONLY REQUIRED WHEN INTERFACING TO A NON-GARMIN AUTOPILOT AND ONE OF THE FOLLOWING:
  1. GNS IS NOT WAAS ENABLED
  2. GTN SOFTWARE IS V6.5 OR EARLIER
  3. GNS SOFTWARE IS V5.30 OR EARLIER
9. CONNECTION TO A GPS ANTENNA IS ONLY REQUIRED WHEN INTERFACED TO A NON WAAS UNIT. THE GLARE SHIELD MOUNTED GPS ANTENNA P/N 011-04036-00 REQUIRES A BNC/TNC ADAPTER P/N 330-01754-00 FOR CONNECTION TO THE G5.
10. REFERENCE LIGHTNING PROTECTION MODULE (LPM) WIRING INTERFACE INTERCONNECT FOR DETAILED INSTALLATION REQUIREMENTS OF THE LPM.
11. IF INTERFACED WITH DUAL NAVIGATORS, CONNECT THE G5 RS-232 TO THE #1 NAVIGATOR. CONNECT THE #2 NAVIGATOR VIA ARINC 429 CONNECTIONS, IF AVAILABLE. THE #2 NAVIGATOR SHALL NOT BE CONNECTED TO THE G5 VIA RS-232. SEE CONFIGURATION TABLE FOR APPLICABLE CONFIGURATION SETTINGS.
12. IT IS ACCEPTABLE TO SPLICE THE MAPMX RS-232 TX WIRE AND GROUND WIRE WITH ANOTHER LRU THAT REQUIRES THESE CONNECTIONS.

**Figure 5-9 G5 (HSI) with GPS/VHF Navigator Notes**

### 5.8.1 HSI Configuration

| Config Page                                                              | Config Option                | Configuration Setting                                                                                         |
|--------------------------------------------------------------------------|------------------------------|---------------------------------------------------------------------------------------------------------------|
| Device Information                                                       | Installation Type            | Certified Instrument                                                                                          |
|                                                                          | Diagnostics/Data Log         | Enabled                                                                                                       |
| Attitude Configuration                                                   | Indicator Type               | Normal                                                                                                        |
|                                                                          | Pitch Display                | Normal                                                                                                        |
|                                                                          | Roll Display                 | For Fixed Type Pointers G5 Config = Ground Pointer<br>or<br>For Movable Type Pointers G5 Config = Sky Pointer |
|                                                                          | Standard Turn Roll Reference | Hide                                                                                                          |
|                                                                          | Automatic Declutter          | Disabled                                                                                                      |
| Air Data                                                                 | Air Data Sensors             | Enabled                                                                                                       |
|                                                                          | Outside Air Temp Sensor      | Enabled<br><b>Note: if a GAD 13 is not installed, select Disabled</b>                                         |
|                                                                          | Vertical Speed Indicator     | (1)(2)                                                                                                        |
| Airspeed<br><br><b>Note: Configure Units prior to setting airspeeds.</b> | VNE                          | (1)(2)(3)                                                                                                     |
|                                                                          | VNO                          | (1)(2)(3)                                                                                                     |
|                                                                          | VSO                          | (1)(2)(3)                                                                                                     |
|                                                                          | VS1                          | (1)(2)(3)                                                                                                     |
|                                                                          | VFE                          | (1)(2)(3)                                                                                                     |
|                                                                          | VA                           | (1)(2)(3)                                                                                                     |
|                                                                          | VX                           | (1)(2)(3)                                                                                                     |
|                                                                          | VY                           | (1)(2)(3)                                                                                                     |



| Config Page            | Config Option              | Configuration Setting                                                                                                                            |
|------------------------|----------------------------|--------------------------------------------------------------------------------------------------------------------------------------------------|
|                        | VG                         | (1)(2)(3)                                                                                                                                        |
|                        | VR                         | (1)(2)(3)                                                                                                                                        |
|                        | VMC                        | (1)(2)(3)                                                                                                                                        |
|                        | VYSE                       | (1)(2)(3)                                                                                                                                        |
| <b>Magnetometer</b>    | Magnetometer               | Enabled                                                                                                                                          |
|                        | Orientation                | Connector Aft<br>Or<br>Connector Forward<br>Or<br>Connector Port<br>Or<br>Connector Starboard                                                    |
| <b>Flight Controls</b> | Garmin Autopilot Servos    | None                                                                                                                                             |
|                        | Analog Autopilot Interface | None<br>Or<br>See Section 5.24 if a Non-Garmin Autopilot is interfaced                                                                           |
| <b>Backlight</b>       | Current Mode               | Automatic                                                                                                                                        |
|                        | Default Mode               | Automatic                                                                                                                                        |
|                        | Minimum Photocell Input    | Default                                                                                                                                          |
|                        | Minimum Display Brightness | Default                                                                                                                                          |
|                        | Maximum Photocell Input    | Default                                                                                                                                          |
|                        | Maximum Display Brightness | Default                                                                                                                                          |
| <b>Display</b>         | Filter Time Constant       | Default                                                                                                                                          |
|                        | HSI Page                   | Enabled                                                                                                                                          |
| <b>Battery</b>         | Power Up Page              | HSI                                                                                                                                              |
|                        | Show Battery Status        | When Using Battery                                                                                                                               |
| <b>GPS</b>             | Automatic Power Off        | On Ground Only                                                                                                                                   |
|                        | Internal GPS Receiver      | Disabled (WAAS Units)<br>Enabled (Non WAAS Units or<br>G5 is connected to GPS antenna)                                                           |
| <b>Navigation</b>      | GPS Data Fields            | Show                                                                                                                                             |
|                        | Navigation Data            | Enabled<br><b>Note: If an autopilot interface is configured, this configuration page is set to ENABLED by default.</b>                           |
| <b>Units</b>           | Selected Course            | Enabled (6)                                                                                                                                      |
|                        | Selected Course 1          | Enabled (7)                                                                                                                                      |
|                        | Selected Course 2          | Enabled (7)                                                                                                                                      |
|                        | VNAV Deviation Scale       | (5)                                                                                                                                              |
|                        | Altitude                   | (1)(2)                                                                                                                                           |
|                        | Distance                   | (1)(2)                                                                                                                                           |
|                        | Airspeed                   | (1)(2)(3)                                                                                                                                        |
| <b>RS-232</b>          | Ground Speed               | (1)(2)                                                                                                                                           |
|                        | Navigation Angle           | Magnetic                                                                                                                                         |
| <b>ARINC 429</b>       | Vertical Speed             | (1)(2)                                                                                                                                           |
|                        | Pressure                   | (1)(2)                                                                                                                                           |
| <b>ARINC 429</b>       | Input Format               | MapMx (WAAS Units)<br>AVIATION (Non WAAS Units)                                                                                                  |
|                        | Output Format              | None                                                                                                                                             |
| <b>ARINC 429</b>       | Output 1                   | EFIS / AIRDATA 1 (SDI 1)<br>(Only used with GTN 6XX/7XX (Xi) and GNS 4XX(W) /<br>5XX(W) with <b>no</b> autopilot or Garmin autopilot interfaced) |
|                        |                            | EFIS / AIRDATA 2 (SDI 1)<br>(Always used with GTN 6XX / 7XX (Xi) and GNS 4XX(W)<br>/ 5XX(W) when Non-Garmin Autopilot is interfaced)             |



| Config Page                    | Config Option | Configuration Setting                                                                                                                         |
|--------------------------------|---------------|-----------------------------------------------------------------------------------------------------------------------------------------------|
|                                | Output 2      | EFIS / AIRDATA 1 (SDI 2)<br>(Only used with GTN 6XX/7XX (Xi) and GNS 4XX(W) / 5XX(W) with <b>no</b> autopilot or Garmin autopilot interfaced) |
|                                |               | EFIS / AIRDATA 2 (SDI 2)<br>(Always used with GTN 6XX / 7XX (Xi) and GNS 4XX(W) / 5XX(W) when Non-Garmin Autopilot is interfaced)             |
|                                | Input 1       | Garmin GPS (SDI 1)<br>(If GTN (Xi)/GNS is #1 navigator)                                                                                       |
|                                | Input 2       | Garmin VOR/ILS (SDI 1) (4)<br>(If GTN (Xi)/GNS is #1 navigator)                                                                               |
|                                | Input 3       | Garmin GPS (SDI 2)<br>(If GTN (Xi)/GNS is #2 navigator)                                                                                       |
|                                | Input 4       | Garmin VOR/ILS (SDI 2) (4)<br>(If GTN (Xi)/GNS is #2 navigator)                                                                               |
| <b>Exit Configuration Mode</b> |               |                                                                                                                                               |

## 5.8.2 GTN 6XX/7XX (Xi) Configuration

| Config Page                                                                                                                                                                                | Config Option                                                                                                                                                                                                   | Configuration Setting                                                                                                                                                                                                           |
|--------------------------------------------------------------------------------------------------------------------------------------------------------------------------------------------|-----------------------------------------------------------------------------------------------------------------------------------------------------------------------------------------------------------------|---------------------------------------------------------------------------------------------------------------------------------------------------------------------------------------------------------------------------------|
| <b>ARINC 429</b>                                                                                                                                                                           | ARINC 429 In (x)<br>(x represents any available ARINC 429 Port)                                                                                                                                                 | Speed = Low<br>Data = EFIS Format 2                                                                                                                                                                                             |
|                                                                                                                                                                                            | ARINC 429 In (x)<br>(x represents any available ARINC 429 Port)<br>(Only used when Non-Garmin Autopilot is interfaced and installed GTN software version is prior to V6.60, GTN Xi does not require this input) | Speed = Low<br>Data = GAD Format 1<br>(Only used when Non-Garmin Autopilot is Interfaced and installed GTN software version is prior to V6.60, GTN Xi does not require this input)                                              |
|                                                                                                                                                                                            | ARINC 429 Out (x)<br>(x represents any available ARINC 429 Port)                                                                                                                                                | Speed = Low<br>Data = GAMA Format 1<br>or<br>Speed = Low<br>Data = GARMIN 429<br>(Only used when VNAV function is enabled and one of the following:<br>when GTN has software version 6.50 or later, when a GTN Xi is installed) |
|                                                                                                                                                                                            | ARINC 429 Out (x)<br>(x represents any available ARINC 429 Port)                                                                                                                                                | Speed = Low<br>Data = ARINC 429                                                                                                                                                                                                 |
|                                                                                                                                                                                            | SDI                                                                                                                                                                                                             | LNAV1 (If GTN (Xi) is #1 navigator)<br>Or<br>LNAV2 (If GTN (Xi) is #2 navigator)                                                                                                                                                |
|                                                                                                                                                                                            |                                                                                                                                                                                                                 |                                                                                                                                                                                                                                 |
| <b>RS-232</b>                                                                                                                                                                              | RS-232 (x)<br>(x represents any available RS-232 Port)                                                                                                                                                          | Output = MapMX Format 1                                                                                                                                                                                                         |
|                                                                                                                                                                                            |                                                                                                                                                                                                                 |                                                                                                                                                                                                                                 |
| <b>Main Indicator (Analog) Configuration</b>                                                                                                                                               | CDI Key                                                                                                                                                                                                         | Enabled                                                                                                                                                                                                                         |
|                                                                                                                                                                                            | Selected Course for GPS                                                                                                                                                                                         | Allowed                                                                                                                                                                                                                         |
|                                                                                                                                                                                            | Selected Course for VLOC                                                                                                                                                                                        | Allowed                                                                                                                                                                                                                         |
|                                                                                                                                                                                            | V-Flag State                                                                                                                                                                                                    | Normal                                                                                                                                                                                                                          |
|                                                                                                                                                                                            |                                                                                                                                                                                                                 |                                                                                                                                                                                                                                 |
| <b>VOR/LOC/GS Configuration</b>                                                                                                                                                            | Nav Radio                                                                                                                                                                                                       | Enabled (4)                                                                                                                                                                                                                     |
|                                                                                                                                                                                            | ARINC 429 Configuration                                                                                                                                                                                         | Tx Speed = Low<br>SDI =<br>VOR/ILS 1 (If GTN (Xi) is #1 navigator)<br>Or<br>VOR/ILS 2 (If GTN (Xi) is #2 navigator)                                                                                                             |
|                                                                                                                                                                                            |                                                                                                                                                                                                                 |                                                                                                                                                                                                                                 |
| <b>Vertical Navigation Configuration</b><br>(Only used when VNAV function is enabled and one of the following:<br>when GTN has software version 6.50 or later, when a GTN Xi is installed) | VNAV                                                                                                                                                                                                            | Enabled                                                                                                                                                                                                                         |
|                                                                                                                                                                                            | Transition to Approach                                                                                                                                                                                          | Disabled                                                                                                                                                                                                                        |
|                                                                                                                                                                                            | VDI Scale                                                                                                                                                                                                       | 500Ft                                                                                                                                                                                                                           |
|                                                                                                                                                                                            |                                                                                                                                                                                                                 |                                                                                                                                                                                                                                 |



| Config Page | Config Option         | Configuration Setting                                                                                   |
|-------------|-----------------------|---------------------------------------------------------------------------------------------------------|
| Main System | Heading Source Input  | Not Connected<br>This selection is made only if the GTN being interfaced to has no other Heading input. |
|             | Altitude Source Input | Connected<br>This selection is made only if the GTN being interfaced to has no other Altitude input.    |

### 5.8.3 GNS 4XX(W) / 5XX(W) Configuration

| Config Page                      | Config Option                                                                                                                        | Configuration Setting                                                                                       |
|----------------------------------|--------------------------------------------------------------------------------------------------------------------------------------|-------------------------------------------------------------------------------------------------------------|
| MAIN ARINC 429 CONFIG Page       | IN (x)<br>(x represents any available ARINC 429 Port)                                                                                | Speed = Low<br>Data = GARMIN G5 (WAAS)<br>EFIS/Airdata (Non-WAAS)                                           |
|                                  | IN (x)<br>(x represents any available ARINC 429 Port)<br>(Only used with non-WAAS GNS <b>and</b> non-Garmin Autopilot is interfaced) | Speed = Low<br>Data = GAD 42<br>(Only used with non-WAAS GNS <b>and</b> non-Garmin Autopilot is interfaced) |
|                                  | OUT                                                                                                                                  | Speed = Low<br>Data = GAMA 429                                                                              |
|                                  | VNAV                                                                                                                                 | Enable Labels                                                                                               |
| MAIN RS232 CONFIG Page           | RS-232 (x)<br>(x represents any available RS-232 Channel)                                                                            | Input = OFF<br>Output = MapMX (WAAS)<br>AVIATION (Non WAAS)                                                 |
| VOR/LOC/GS ARINC 429 CONFIG Page | SPEED                                                                                                                                | RX = Low (4)<br>TX = Low                                                                                    |
|                                  | SDI                                                                                                                                  | VOR/ILS 1 (If GNS is #1 navigator) (4)<br>Or<br>VOR/ILS 2 (If GNS is #2 navigator) (4)                      |

### 5.8.4 GNS 480 Configuration

| Config Page                        | Config Option                                             | Configuration Setting                                                                                           |
|------------------------------------|-----------------------------------------------------------|-----------------------------------------------------------------------------------------------------------------|
| GND Maint Serial Setup             | CH (x)<br>(x represents any available Serial Channel)     | Output = MapMX                                                                                                  |
| GND Maint ARINC 429 Setup          | CH In (x)<br>(x represents any available ARINC 429 Port)  | SEL = EFIS<br>SPEED = Low<br>SDI =<br>SYS1 (If GNS is #1 navigator)<br>Or<br>SYS2 (If GNS is #2 navigator)      |
|                                    | CH Out (x)<br>(x represents any available ARINC 429 Port) | SEL = GAMA 429<br>SPEED = Low<br>SDI =<br>SYS1 (If GNS is #1 navigator)<br>Or<br>SYS2 (If GNS is #2 navigator)  |
|                                    | CH Out (x)<br>(x represents any available ARINC 429 Port) | SEL = VOR / ILS<br>SPEED = Low<br>SDI =<br>SYS1 (If GNS is #1 navigator)<br>Or<br>SYS2 (If GNS is #2 navigator) |
| GND Maint Resolver Interface Setup | Resolver                                                  | Not Installed                                                                                                   |
| GND Maint Miscellaneous Setup      | CDI Select                                                | Use                                                                                                             |

Note 1: Set configuration values and units to match the values indicated in the appropriate AFM and document settings in the space provided.





Note 2: If the aircraft has no AFM set the values as determined by the existing placards, instrument bugs or instrument markings.

Note 3: Existing placards related to airspeed limitations must be retained.

Note 4: Not applicable to GPS navigators that has no VHF Navigation output. Reference Note 5 in Figure 5-9.

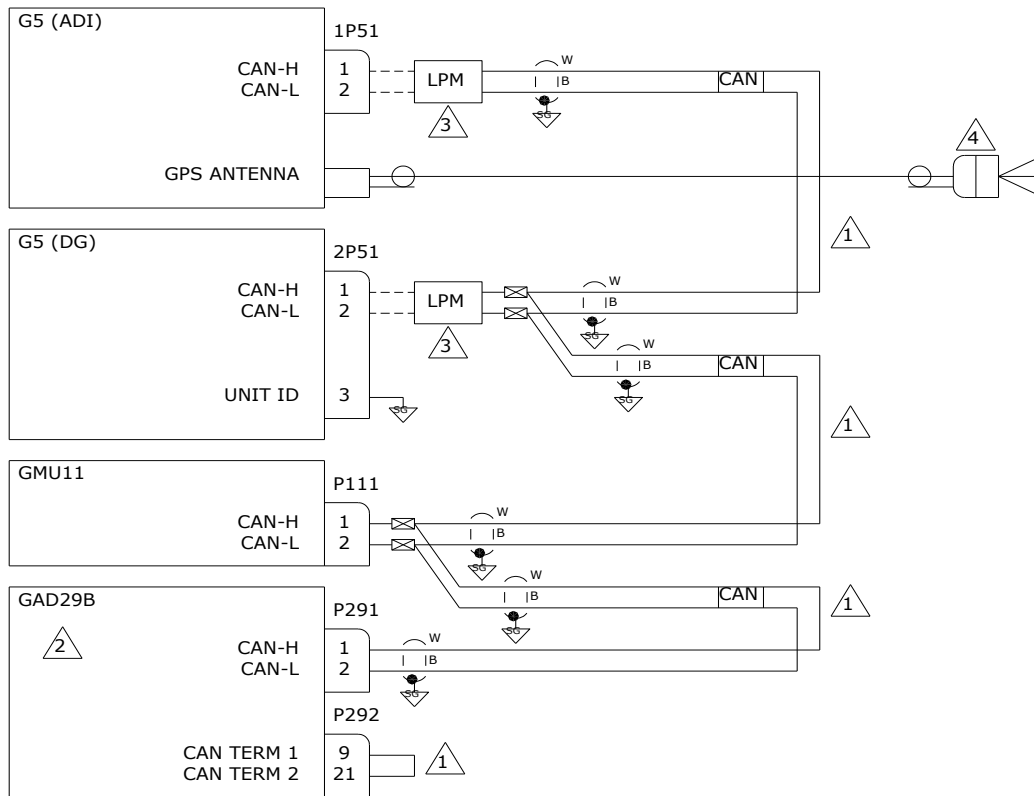
Note 5: Setting can remain at default setting, not supported in this configuration.

Note 6: The “Selected Course” will display when only one navigator is interfaced to the G5.

Note 7: “Selected Course 1” and “Selected Course 2” will display when dual navigators are interfaced.

*This area intentionally blank*

## 5.9 Dual G5 without Navigator



- 1 CAN BUS LRUS MAY BE IN ANY ORDER ALONG BACKBONE AS LONG AS CAN BUS BACKBONE STRUCTURE GUIDELINES ARE FOLLOWED. REFER TO THE CAN BUS TERMINATION SECTION FOR FURTHER CAN BUS INFORMATION.
- 2 GAD29B IS INSTALLED WHEN INTERFACING TO AN AUTOPILOT. FOR NON-GARMIN AUTOPILOT INTERCONNECTS, SEE GAD29B INTERFACE TO A NON-GARMIN AUTOPILOT INTERCONNECT DIAGRAMS FOR FURTHER INFORMATION.
- 3 REFERENCE LIGHTNING PROTECTION MODULE (LPM) WIRING INTERFACE INTERCONNECT FOR DETAILED INSTALLATION REQUIREMENTS OF THE LPM.
- 4 THE GLARE SHIELD MOUNTED GPS ANTENNA P/N 011-04036-00 REQUIRES A BNC/TNC ADAPTER P/N 330-01754-00 FOR CONNECTION TO THE G5.

**Figure 5-10 Dual G5 without Navigator**

### 5.9.1 ADI Configuration

| Config Page            | Config Option                | Configuration Setting                                                                                         |
|------------------------|------------------------------|---------------------------------------------------------------------------------------------------------------|
| Device Information     | Installation Type            | Certified Instrument                                                                                          |
|                        | Diagnostics/Data Log         | Enabled                                                                                                       |
| Attitude Configuration | Indicator Type               | Normal                                                                                                        |
|                        | Pitch Display                | Normal                                                                                                        |
|                        | Roll Display                 | For Fixed Type Pointers G5 Config = Ground Pointer<br>or<br>For Movable Type Pointers G5 Config = Sky Pointer |
|                        | Standard Turn Roll Reference | Hide                                                                                                          |
|                        | Automatic Declutter          | Enabled                                                                                                       |
| Air Data               | Air Data Sensors             | Enabled                                                                                                       |
|                        | Outside Air Temp Sensor      | Enabled<br><b>Note: if a GAD 13 is not installed, select Disabled</b>                                         |
|                        | Vertical Speed Indicator     | (1)(2)                                                                                                        |



| Config Page                                              | Config Option              | Configuration Setting                                                                                                  |
|----------------------------------------------------------|----------------------------|------------------------------------------------------------------------------------------------------------------------|
| <b>Airspeed</b>                                          | VNE                        | (1)(2)(3)                                                                                                              |
| <b>Note: Configure Units prior to setting airspeeds.</b> | VNO                        | (1)(2)(3)                                                                                                              |
|                                                          | VSO                        | (1)(2)(3)                                                                                                              |
|                                                          | VS1                        | (1)(2)(3)                                                                                                              |
|                                                          | VFE                        | (1)(2)(3)                                                                                                              |
|                                                          | VA                         | (1)(2)(3)                                                                                                              |
|                                                          | VX                         | (1)(2)(3)                                                                                                              |
|                                                          | VY                         | (1)(2)(3)                                                                                                              |
|                                                          | VG                         | (1)(2)(3)                                                                                                              |
|                                                          | VR                         | (1)(2)(3)                                                                                                              |
|                                                          | VMC                        | (1)(2)(3)                                                                                                              |
|                                                          | VYSE                       | (1)(2)(3)                                                                                                              |
| <b>Magnetometer</b>                                      | Magnetometer               | Enabled (if GMU 11 is connected)<br>Disabled (if GMU 11 is not connected)                                              |
|                                                          | Orientation                | Connector Aft<br>Or<br>Connector Forward<br>Or<br>Connector Port<br>Or<br>Connector Starboard                          |
| <b>Flight Controls</b>                                   | Garmin Autopilot Servos    | None                                                                                                                   |
|                                                          | Analog Autopilot Interface | None<br>Or<br>See Section 5.24 if a Non-Garmin Autopilot is interfaced                                                 |
| <b>Backlight</b>                                         | Current Mode               | Automatic                                                                                                              |
|                                                          | Default Mode               | Automatic                                                                                                              |
|                                                          | Minimum Photocell Input    | Default                                                                                                                |
|                                                          | Minimum Display Brightness | Default                                                                                                                |
|                                                          | Maximum Photocell Input    | Default                                                                                                                |
|                                                          | Maximum Display Brightness | Default                                                                                                                |
|                                                          | Filter Time Constant       | Default                                                                                                                |
| <b>Display</b>                                           | HSI Page                   | Disabled                                                                                                               |
|                                                          | Power Up Page              | PFD                                                                                                                    |
| <b>Battery</b>                                           | Show Battery Status        | When Using Battery                                                                                                     |
|                                                          | Automatic Power Off        | On Ground Only                                                                                                         |
| <b>GPS</b>                                               | Internal GPS Receiver      | Enabled                                                                                                                |
|                                                          | GPS Data Fields            | Show                                                                                                                   |
| <b>Navigation</b>                                        | Navigation Data            | Disable<br><b>Note: If an autopilot interface is configured, this configuration page is set to ENABLED by default.</b> |
|                                                          | Selected Course            | (4)                                                                                                                    |
|                                                          | VNAV Deviation Scale       | (4)                                                                                                                    |
| <b>Units</b>                                             | Altitude                   | (1)(2)                                                                                                                 |
|                                                          | Distance                   | (1)(2)                                                                                                                 |
|                                                          | Airspeed                   | (1)(2)(3)                                                                                                              |
|                                                          | Ground Speed               | (1)(2)                                                                                                                 |
|                                                          | Navigation Angle           | Magnetic                                                                                                               |
|                                                          | Vertical Speed             | (1)(2)                                                                                                                 |
|                                                          | Pressure                   | (1)(2)                                                                                                                 |
| <b>RS-232</b>                                            | Input Format               | None                                                                                                                   |
|                                                          | Output Format              | None                                                                                                                   |
| <b>ARINC 429</b>                                         | Output 1                   | None                                                                                                                   |
|                                                          | Output 2                   | None                                                                                                                   |
|                                                          | Input 1                    | None                                                                                                                   |



| Config Page                    | Config Option | Configuration Setting |
|--------------------------------|---------------|-----------------------|
|                                | Input 2       | None                  |
|                                | Input 3       | None                  |
|                                | Input 4       | None                  |
| <b>Exit Configuration Mode</b> |               |                       |

## 5.9.2 DG Configuration

| Config Page                    | Config Option              | Configuration Setting |
|--------------------------------|----------------------------|-----------------------|
| <b>Device Information</b>      | Installation Type          | Certified Instrument  |
|                                | Diagnostics/Data Log       | Enabled               |
| <b>Attitude Configuration</b>  |                            |                       |
|                                | Automatic Declutter        | Disabled              |
| <b>Backlight</b>               | Current Mode               | Automatic             |
|                                | Default Mode               | Automatic             |
|                                | Minimum Photocell Input    | Default               |
|                                | Minimum Display Brightness | Default               |
|                                | Maximum Photocell Input    | Default               |
|                                | Maximum Display Brightness | Default               |
| <b>Display</b>                 | Filter Time Constant       | Default               |
|                                | HSI Page                   | Enabled               |
| <b>Battery</b>                 | Power Up Page              | HSI                   |
|                                | Show Battery Status        | When Using Battery    |
| <b>GPS</b>                     | Automatic Power Off        | On Ground Only        |
|                                | Internal GPS Receiver      | Disabled              |
| <b>RS-232</b>                  |                            |                       |
|                                | Input Format               | None                  |
| <b>Exit Configuration Mode</b> |                            |                       |
|                                | Output Format              | None                  |

Note 1: Set configuration values and units to match the values indicated in the appropriate AFM and document settings in the space provided.

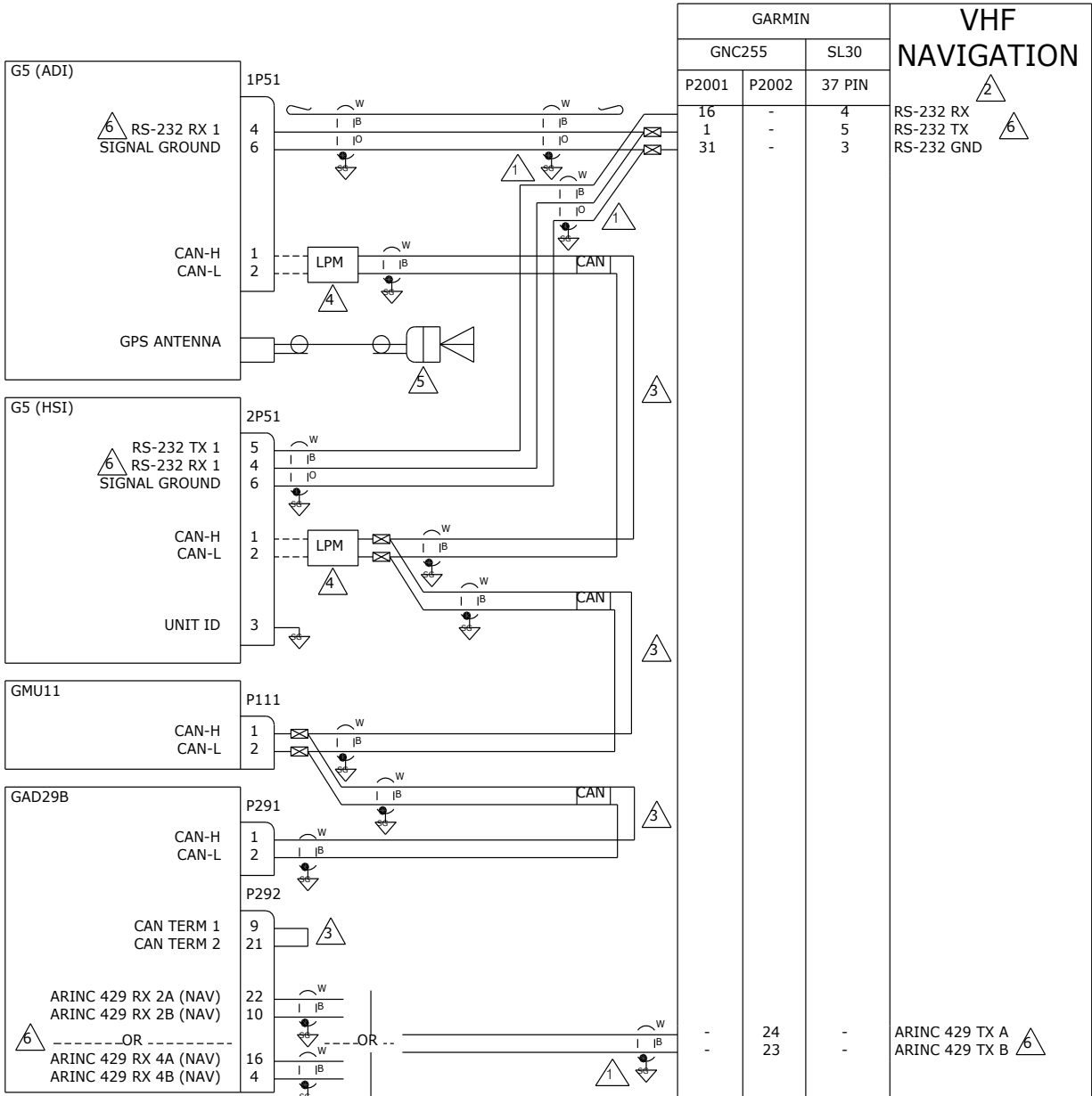
Note 2: If the aircraft has no AFM set the values as determined by the existing placards, instrument bugs or instrument markings.

Note 3: Existing placards related to airspeed limitations must be retained.

Note 4: Setting can remain at default setting, not supported in this configuration.

*This area intentionally blank*

## 5.10 Dual G5 with VHF Navigator



- 1 IT IS ACCEPTABLE TO SPLICE WIRES TO EXISTING WIRING OR EXISTING WIRING MAY BE RE-USED IF WIRE LENGTH IS SUFFICIENT TO REACH G5/GAD29B. TERMINATE SHIELD GROUNDS TO CONNECTOR BACKSHELL. SHIELD LEADS MUST BE MAX 3.0 INCHES. REFER TO UNIT INSTALLATION MANUALS FOR MORE INFORMATION.
- 2 THIS STC DOES NOT APPROVE A CDI INTERFACED WITH THE SAME NAVIGATOR AS THE G5. REMOVE ANY EXISTING CDI INTERFACED WITH THIS NAVIGATOR.
- 3 CAN BUS LRUS MAY BE IN ANY ORDER ALONG BACKBONE AS LONG AS CAN BUS BACKBONE STRUCTURE GUIDELINES ARE FOLLOWED. REFER TO THE CAN BUS TERMINATION SECTION FOR FURTHER CAN BUS INFORMATION.
- 4 REFERENCE LIGHTNING PROTECTION MODULE (LPM) WIRING INTERFACE INTERCONNECT FOR DETAILED INSTALLATION REQUIREMENTS OF THE LPM.
- 5 THE GLARE SHIELD MOUNTED GPS ANTENNA P/N 011-04036-00 REQUIRES A BNC/TNC ADAPTER P/N 330-01754-00 FOR CONNECTION TO THE G5.
- 6 IF INTERFACED WITH DUAL NAVIGATORS, CONNECT THE G5 RS-232 AND ONE SET OF ARINC 429 CONNECTIONS TO THE #1 NAVIGATOR. CONNECT THE #2 NAVIGATOR VIA ONE SET OF THE ARINC 429 CONNECTIONS. SEE CONFIGURATION TABLE FOR APPLICABLE CONFIGURATION SETTINGS.

**Figure 5-11 Dual G5 with VHF Navigator**



## 5.10.1 ADI Configuration

| Config Page                                                          | Config Option                | Configuration Setting                                                                                         |
|----------------------------------------------------------------------|------------------------------|---------------------------------------------------------------------------------------------------------------|
| Device Information                                                   | Installation Type            | Certified Instrument                                                                                          |
|                                                                      | Diagnostics/Data Log         | Enabled                                                                                                       |
| Attitude Configuration                                               | Indicator Type               | Normal                                                                                                        |
|                                                                      | Pitch Display                | Normal                                                                                                        |
|                                                                      | Roll Display                 | For Fixed Type Pointers G5 Config = Ground Pointer<br>or<br>For Movable Type Pointers G5 Config = Sky Pointer |
|                                                                      | Standard Turn Roll Reference | Hide                                                                                                          |
|                                                                      | Automatic Declutter          | Enabled                                                                                                       |
| Air Data                                                             | Air Data Sensors             | Enabled                                                                                                       |
|                                                                      | Outside Air Temp Sensor      | Enabled<br><b>Note: if a GAD 13 is not installed, select Disabled</b>                                         |
|                                                                      | Vertical Speed Indicator     | (1)(2)                                                                                                        |
| Airspeed<br><br>Note: Configure Units prior to setting<br>airspeeds. | VNE                          | (1)(2)(3)                                                                                                     |
|                                                                      | VNO                          | (1)(2)(3)                                                                                                     |
|                                                                      | VSO                          | (1)(2)(3)                                                                                                     |
|                                                                      | VS1                          | (1)(2)(3)                                                                                                     |
|                                                                      | VFE                          | (1)(2)(3)                                                                                                     |
|                                                                      | VA                           | (1)(2)(3)                                                                                                     |
|                                                                      | VX                           | (1)(2)(3)                                                                                                     |
|                                                                      | VY                           | (1)(2)(3)                                                                                                     |
|                                                                      | VG                           | (1)(2)(3)                                                                                                     |
|                                                                      | VR                           | (1)(2)(3)                                                                                                     |
|                                                                      | VMC                          | (1)(2)(3)                                                                                                     |
| VYSE                                                                 | (1)(2)(3)                    |                                                                                                               |
| Magnetometer                                                         | Magnetometer                 | Enabled (if GMU 11 is connected)<br>Disabled (if GMU 11 is not connected)                                     |
|                                                                      | Orientation                  | Connector Aft<br>Or<br>Connector Forward<br>Or<br>Connector Port<br>Or<br>Connector Starboard                 |
| Flight Controls                                                      | Garmin Autopilot Servos      | None                                                                                                          |
|                                                                      | Analog Autopilot Interface   | None<br>Or<br>See Section 5.24 if a Non-Garmin Autopilot is interfaced                                        |
| Backlight                                                            | Current Mode                 | Automatic                                                                                                     |
|                                                                      | Default Mode                 | Automatic                                                                                                     |
|                                                                      | Minimum Photocell Input      | Default                                                                                                       |
|                                                                      | Minimum Display Brightness   | Default                                                                                                       |
|                                                                      | Maximum Photocell Input      | Default                                                                                                       |
|                                                                      | Maximum Display Brightness   | Default                                                                                                       |
|                                                                      | Filter Time Constant         | Default                                                                                                       |
| Display                                                              | HSI Page                     | Disabled                                                                                                      |
|                                                                      | Power Up Page                | PFD                                                                                                           |
| Battery                                                              | Show Battery Status          | When Using Battery                                                                                            |
|                                                                      | Automatic Power Off          | On Ground Only                                                                                                |
| GPS                                                                  | Internal GPS Receiver        | Enabled                                                                                                       |
|                                                                      | GPS Data Fields              | Show                                                                                                          |



| Config Page             | Config Option        | Configuration Setting                                                                                                  |
|-------------------------|----------------------|------------------------------------------------------------------------------------------------------------------------|
| Navigation              | Navigation Data      | Enabled<br><b>Note: If an autopilot interface is configured, this configuration page is set to ENABLED by default.</b> |
|                         | Selected Course      | Enabled (5)                                                                                                            |
|                         | Selected Course 1    | Enabled (6)                                                                                                            |
|                         | Selected Course 2    | Enabled (6)                                                                                                            |
|                         | VNAV Deviation Scale | (4)                                                                                                                    |
| Units                   | Altitude             | (1)(2)                                                                                                                 |
|                         | Distance             | (1)(2)                                                                                                                 |
|                         | Airspeed             | (1)(2)(3)                                                                                                              |
|                         | Ground Speed         | (1)(2)                                                                                                                 |
|                         | Navigation Angle     | Magnetic                                                                                                               |
|                         | Vertical Speed       | (1)(2)                                                                                                                 |
|                         | Pressure             | (1)(2)                                                                                                                 |
| RS-232                  | Input Format         | Garmin VHF NAV Radio                                                                                                   |
|                         | Output Format        | None                                                                                                                   |
| ARINC 429               | Output 1             | None                                                                                                                   |
|                         | Output 2             | None                                                                                                                   |
|                         | Input 1              | None                                                                                                                   |
|                         | Input 2              | Garmin VOR/ILS (SDI 1)<br>(If GNC is #1 Navigator)                                                                     |
|                         | Input 3              | None                                                                                                                   |
|                         | Input 4              | Garmin VOR/ILS (SDI 2)<br>(If GNC is #2 Navigator)                                                                     |
| Exit Configuration Mode |                      |                                                                                                                        |

### 5.10.2 HSI Configuration

| Config Page             | Config Option              | Configuration Setting |
|-------------------------|----------------------------|-----------------------|
| Device Information      | Installation Type          | Certified Instrument  |
|                         | Diagnostics/Data Log       | Enabled               |
| Attitude Configuration  | Automatic Declutter        | Disabled              |
| Backlight               | Current Mode               | Automatic             |
|                         | Default Mode               | Automatic             |
|                         | Minimum Photocell Input    | Default               |
|                         | Minimum Display Brightness | Default               |
|                         | Maximum Photocell Input    | Default               |
|                         | Maximum Display Brightness | Default               |
|                         | Filter Time Constant       | Default               |
| Display                 | HSI Page                   | Enabled               |
|                         | Power Up Page              | HSI                   |
| Battery                 | Show Battery Status        | When Using Battery    |
|                         | Automatic Power Off        | On Ground Only        |
| GPS                     | Internal GPS Receiver      | Disabled              |
| RS-232                  | Input Format               | Garmin VHF NAV Radio  |
|                         | Output Format              | Garmin VHF NAV Radio  |
| Exit Configuration Mode |                            |                       |



### 5.10.3 GNC 255 Configuration

| Config Page       | Config Option      | Configuration Setting                                                                                  |
|-------------------|--------------------|--------------------------------------------------------------------------------------------------------|
| Sys Configuration | RS 232 Serial Port | IO Mode = NMEA                                                                                         |
| NAV Configuration | CDI Indicator      | Serial (If GNC255 is installed as #1 navigator)<br>Or<br>None (If GNC255 is installed as #2 navigator) |
|                   | ARINC 429          | Tx = Low<br>SDI =<br>VOR/ILS 1 (If GNC is #1 Navigator)<br>Or<br>VOR/ILS 2 (If GNC is #2 Navigator)    |

### 5.10.4 SL30 Configuration

| Config Page            | Config Option      | Configuration Setting |
|------------------------|--------------------|-----------------------|
| Sys Configuration      | RS 232 Serial Port | No Setting            |
| Attitude Configuration | Indicator Type     | TYPE = Serial         |

Note 1: Set configuration values and units to match the values indicated in the appropriate AFM and document settings in the space provided.

Note 2: If the aircraft has no AFM set the values as determined by the existing placards, instrument bugs or instrument markings.

Note 3: Existing placards related to airspeed limitations must be retained.

Note 4: Setting can remain at default setting, not supported in this configuration.

Note 5: The “Selected Course” will display when only one navigator is interfaced to the G5.

Note 6: “Selected Course 1” and “Selected Course 2” will display when dual navigators are interfaced.

*This area intentionally blank*



## 5.11 Dual G5 with GPS/VHF Navigator

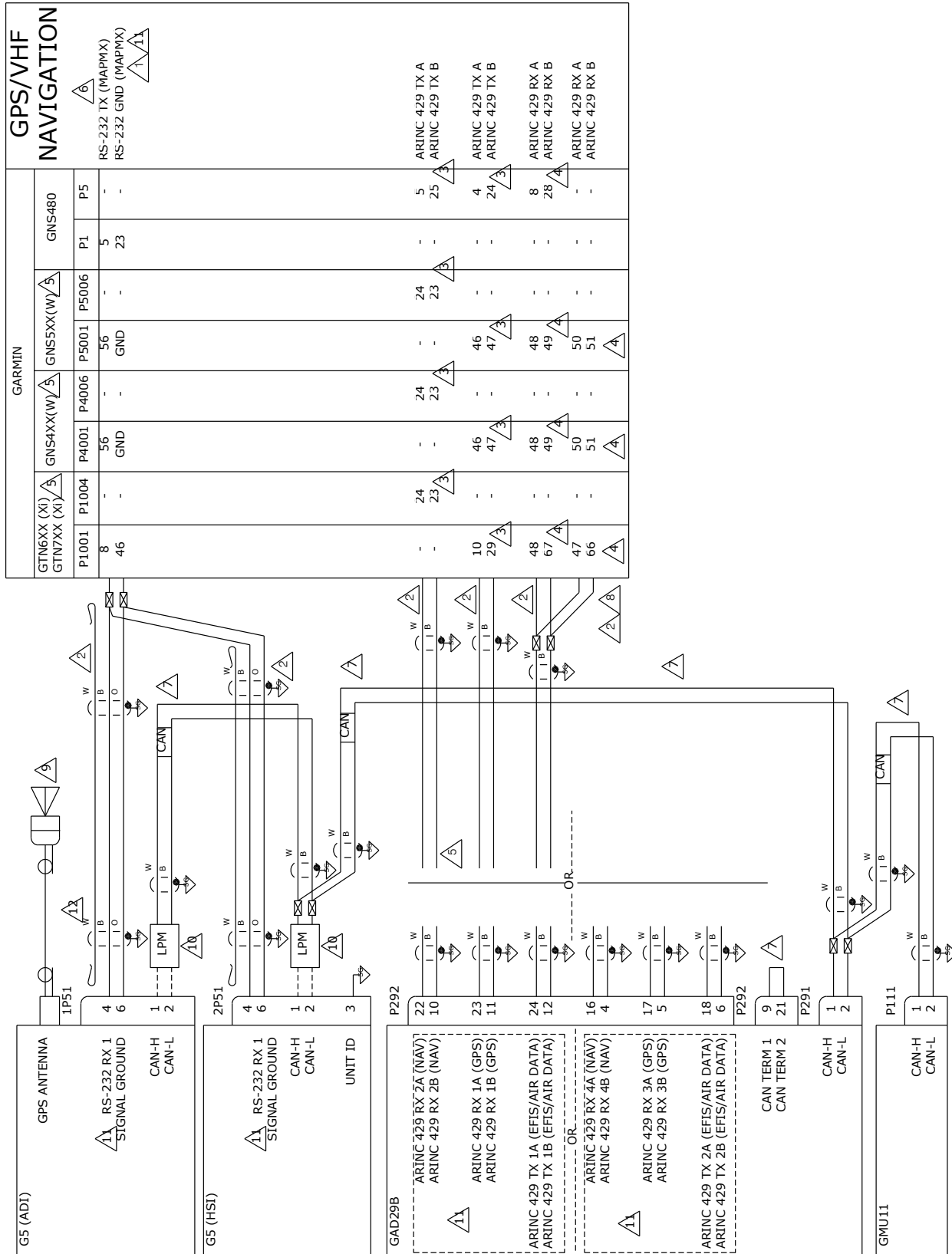


Figure 5-12 Dual G5 with GPS/VHF Navigator



1. CONNECT TO AN APPROPRIATELY CONFIGURED, AVAILABLE RS-232 PORT.
2. IT IS ACCEPTABLE TO SPLICE WIRES TO EXISTING WIRING OR EXISTING WIRING MAY BE RE-USED IF WIRE LENGTH IS SUFFICIENT TO REACH G5/GAD29B. TERMINATE SHIELD GROUNDS TO CONNECTOR BACKSHELL. SHIELD LEADS MUST BE MAX 3.0 INCHES. REFER TO UNIT INSTALLATION MANUALS FOR MORE INFORMATION.
3. CONNECT TO ANY APPROPRIATELY CONFIGURED, AVAILABLE ARINC 429 TX PORT.
4. CONNECT TO ANY APPROPRIATELY CONFIGURED, AVAILABLE ARINC 429 RX PORT.
5. ARINC 429 TX (NAV) CONNECTION NOT APPLICABLE WHEN INTERFACING WITH GTN625/725 UNITS OR GNS4XX(W)/5XX(W) UNITS WITHOUT VHF NAVIGATION.
6. THIS STC DOES NOT APPROVE A CDI INTERFACED WITH THE SAME NAVIGATOR AS THE G5. REMOVE ANY EXISTING CDI INTERFACED WITH THIS NAVIGATOR.
7. CAN BUS LRUS MAY BE IN ANY ORDER ALONG BACKBONE AS LONG AS CAN BUS BACKBONE STRUCTURE GUIDELINES ARE FOLLOWED. REFER TO THE CAN BUS TERMINATION SECTION FOR FURTHER CAN BUS INFORMATION.
8. CONNECTION ONLY REQUIRED WHEN INTERFACING TO A NON-GARMIN AUTOPILOT AND ONE OF THE FOLLOWING:
  1. GNS IS NOT WAAS ENABLED
  2. GTN SOFTWARE IS V6.5 OR EARLIER
  3. GNS SOFTWARE IS V5.30 OR EARLIER
9. CONNECTION TO A GPS ANTENNA IS ONLY REQUIRED WHEN INTERFACED TO A NON WAAS UNIT. THE GLARE SHIELD MOUNTED GPS ANTENNA P/N 011-04036-00 REQUIRES A BNC/TNC ADAPTER P/N 330-01754-00 FOR CONNECTION TO THE G5.
10. REFERENCE LIGHTNING PROTECTION MODULE (LPM) WIRING INTERFACE INTERCONNECT FOR DETAILED INSTALLATION REQUIREMENTS OF THE LPM.
11. IF INTERFACED WITH DUAL NAVIGATORS, CONNECT THE G5 RS-232 AND ONE SET OF ARINC 429 CONNECTIONS TO THE #1 NAVIGATOR. CONNECT THE #2 NAVIGATOR VIA ONE SET OF THE ARINC 429 CONNECTIONS. SEE CONFIGURATION TABLE FOR APPLICABLE CONFIGURATION SETTINGS.
12. IT IS ACCEPTABLE TO SPLICE THE MAPMX RS-232 TX WIRE AND GROUND WIRE WITH ANOTHER LRU THAT REQUIRES THESE CONNECTIONS.

**Figure 5-13 Dual G5 with GPS/VHF Navigator Notes**

### 5.11.1 ADI Configuration

| Config Page                                                                  | Config Option                | Configuration Setting                                                                                         |
|------------------------------------------------------------------------------|------------------------------|---------------------------------------------------------------------------------------------------------------|
| Device Information                                                           | Installation Type            | Certified Instrument                                                                                          |
|                                                                              | Diagnostics/Data Log         | Enabled                                                                                                       |
| Attitude Configuration                                                       | Indicator Type               | Normal                                                                                                        |
|                                                                              | Pitch Display                | Normal                                                                                                        |
|                                                                              | Roll Display                 | For Fixed Type Pointers G5 Config = Ground Pointer<br>or<br>For Movable Type Pointers G5 Config = Sky Pointer |
|                                                                              | Standard Turn Roll Reference | Hide                                                                                                          |
|                                                                              | Automatic Declutter          | Enabled                                                                                                       |
| Air Data                                                                     | Air Data Sensors             | Enabled                                                                                                       |
|                                                                              | Outside Air Temp Sensor      | Enabled<br><b>Note: if a GAD 13 is not installed, select Disabled</b>                                         |
|                                                                              | Vertical Speed Indicator     | (1)(2)                                                                                                        |
| Airspeed<br><br><b>Note: Configure Units prior to setting<br/>airspeeds.</b> | VNE                          | (1)(2)(3)                                                                                                     |
|                                                                              | VNO                          | (1)(2)(3)                                                                                                     |
|                                                                              | VSO                          | (1)(2)(3)                                                                                                     |
|                                                                              | VS1                          | (1)(2)(3)                                                                                                     |
|                                                                              | VFE                          | (1)(2)(3)                                                                                                     |
|                                                                              | VA                           | (1)(2)(3)                                                                                                     |
|                                                                              | VX                           | (1)(2)(3)                                                                                                     |
|                                                                              | VY                           | (1)(2)(3)                                                                                                     |
|                                                                              | VG                           | (1)(2)(3)                                                                                                     |
|                                                                              | VR                           | (1)(2)(3)                                                                                                     |
| VMC                                                                          | (1)(2)(3)                    |                                                                                                               |



| Config Page     | Config Option              | Configuration Setting                                                                                                                                                                                                                                                              |
|-----------------|----------------------------|------------------------------------------------------------------------------------------------------------------------------------------------------------------------------------------------------------------------------------------------------------------------------------|
|                 | VYSE                       | (1)(2)(3)                                                                                                                                                                                                                                                                          |
| Magnetometer    | Magnetometer               | Enabled                                                                                                                                                                                                                                                                            |
|                 | Orientation                | Connector Aft<br>Or<br>Connector Forward<br>Or<br>Connector Port<br>Or<br>Connector Starboard                                                                                                                                                                                      |
| Flight Controls | Garmin Autopilot Servos    | None                                                                                                                                                                                                                                                                               |
|                 | Analog Autopilot Interface | None<br>Or<br>See Section 5.24 if a Non-Garmin Autopilot is interfaced                                                                                                                                                                                                             |
| Backlight       | Current Mode               | Automatic                                                                                                                                                                                                                                                                          |
|                 | Default Mode               | Automatic                                                                                                                                                                                                                                                                          |
|                 | Minimum Photocell Input    | Default                                                                                                                                                                                                                                                                            |
|                 | Minimum Display Brightness | Default                                                                                                                                                                                                                                                                            |
|                 | Maximum Photocell Input    | Default                                                                                                                                                                                                                                                                            |
|                 | Maximum Display Brightness | Default                                                                                                                                                                                                                                                                            |
|                 | Filter Time Constant       | Default                                                                                                                                                                                                                                                                            |
| Display         | HSI Page                   | Disabled                                                                                                                                                                                                                                                                           |
|                 | Power Up Page              | PFD                                                                                                                                                                                                                                                                                |
| Battery         | Show Battery Status        | When Using Battery                                                                                                                                                                                                                                                                 |
|                 | Automatic Power Off        | On Ground Only                                                                                                                                                                                                                                                                     |
| GPS             | Internal GPS Receiver      | Disabled (WAAS Units)<br>Enabled (Non WAAS Units or<br>G5 is connected to GPS antenna)                                                                                                                                                                                             |
|                 | GPS Data Fields            | Show                                                                                                                                                                                                                                                                               |
| Navigation      | Navigation Data            | Enabled<br><b>Note: If an autopilot interface is configured, this configuration page is set to ENABLED by default.</b>                                                                                                                                                             |
|                 | Selected Course            | Enabled (5)                                                                                                                                                                                                                                                                        |
|                 | Selected Course 1          | Enabled (6)                                                                                                                                                                                                                                                                        |
|                 | Selected Course 2          | Enabled (6)                                                                                                                                                                                                                                                                        |
|                 | VNAV Deviation Scale       | (4)                                                                                                                                                                                                                                                                                |
| Units           | Altitude                   | (1)(2)                                                                                                                                                                                                                                                                             |
|                 | Distance                   | (1)(2)                                                                                                                                                                                                                                                                             |
|                 | Airspeed                   | (1)(2)(3)                                                                                                                                                                                                                                                                          |
|                 | Ground Speed               | (1)(2)                                                                                                                                                                                                                                                                             |
|                 | Navigation Angle           | Magnetic                                                                                                                                                                                                                                                                           |
|                 | Vertical Speed             | (1)(2)                                                                                                                                                                                                                                                                             |
|                 | Pressure                   | (1)(2)                                                                                                                                                                                                                                                                             |
| RS-232          | Input Format               | MapMx (WAAS Units)<br>AVIATION (Non WAAS Units)                                                                                                                                                                                                                                    |
|                 | Output Format              | None                                                                                                                                                                                                                                                                               |
| ARINC 429       | Output 1                   | EFIS / AIRDATA 1 (SDI 1)<br>(Only used with GTN 6XX / 7XX (Xi) and GNS 4XX(W) / 5XX(W) with <b>no</b> autopilot or Garmin autopilot interfaced)                                                                                                                                    |
|                 | Output 2                   | EFIS / AIRDATA 2 (SDI 1)<br>(Always used with GTN 6XX / 7XX (Xi) and GNS 4XX(W) / 5XX(W) when Non-Garmin Autopilot is interfaced)<br>EFIS / AIRDATA 1 (SDI 2)<br>(Only used with GTN 6XX/7XX (Xi) and GNS 4XX(W) / 5XX(W) with <b>no</b> autopilot or Garmin autopilot interfaced) |



| Config Page                    | Config Option | Configuration Setting                                                                                                             |
|--------------------------------|---------------|-----------------------------------------------------------------------------------------------------------------------------------|
|                                |               | EFIS / AIRDATA 2 (SDI 2)<br>(Always used with GTN 6XX / 7XX (Xi) and GNS 4XX(W) / 5XX(W) when Non-Garmin Autopilot is interfaced) |
|                                | Input 1       | Garmin GPS (SDI 1)<br>(If GTN (Xi)/GNS is #1 navigator)                                                                           |
|                                | Input 2       | Garmin VOR/ILS (SDI 1) (7)<br>(If GTN (Xi)/GNS is #1 navigator)                                                                   |
|                                | Input 3       | Garmin GPS (SDI 2)<br>(If GTN (Xi)/GNS is #2 navigator)                                                                           |
|                                | Input 4       | Garmin VOR/ILS (SDI 2) (7)<br>(If GTN (Xi)/GNS is #2 navigator)                                                                   |
| <b>Exit Configuration Mode</b> |               |                                                                                                                                   |

### 5.11.2 HSI Configuration

| Config Page                    | Config Option              | Configuration Setting                           |
|--------------------------------|----------------------------|-------------------------------------------------|
| <b>Device Information</b>      | Installation Type          | Certified Instrument                            |
|                                | Diagnostics/Data Log       | Enabled                                         |
| <b>Attitude Configuration</b>  |                            |                                                 |
|                                | Automatic Declutter        | Disabled                                        |
| <b>Backlight</b>               |                            |                                                 |
|                                | Current Mode               | Automatic                                       |
|                                | Default Mode               | Automatic                                       |
|                                | Minimum Photocell Input    | Default                                         |
|                                | Minimum Display Brightness | Default                                         |
|                                | Maximum Photocell Input    | Default                                         |
|                                | Maximum Display Brightness | Default                                         |
|                                | Filter Time Constant       | Default                                         |
| <b>Display</b>                 |                            |                                                 |
|                                | HSI Page                   | Enabled                                         |
|                                | Power Up Page              | HSI                                             |
| <b>Battery</b>                 |                            |                                                 |
|                                | Show Battery Status        | When Using Battery                              |
|                                | Automatic Power Off        | On Ground Only                                  |
| <b>GPS</b>                     |                            |                                                 |
|                                | Internal GPS Receiver      | Disabled                                        |
| <b>RS-232</b>                  |                            |                                                 |
|                                | Input Format               | MapMX (WAAS Units)<br>AVIATION (non WAAS Units) |
|                                | Output Format              | None                                            |
| <b>Exit Configuration Mode</b> |                            |                                                 |

### 5.11.3 GTN 6XX/7XX (Xi) Configuration

| Config Page      | Config Option                                                                                                                                                                                                   | Configuration Setting                                                                                                                                                                                                           |
|------------------|-----------------------------------------------------------------------------------------------------------------------------------------------------------------------------------------------------------------|---------------------------------------------------------------------------------------------------------------------------------------------------------------------------------------------------------------------------------|
| <b>ARINC 429</b> | ARINC 429 In (x)<br>(x represents any available ARINC 429 Port)                                                                                                                                                 | Speed = Low<br>Data = EFIS Format 2                                                                                                                                                                                             |
|                  | ARINC 429 In (x)<br>(x represents any available ARINC 429 Port)<br>(Only used when Non-Garmin Autopilot is interfaced and installed GTN software version is prior to V6.60, GTN Xi does not require this input) | Speed = Low<br>Data = GAD Format 1<br>(Only used when Non-Garmin Autopilot is Interfaced and installed GTN software version is prior to V6.60, GTN Xi does not require this input)                                              |
|                  | ARINC 429 Out (x)<br>(x represents any available ARINC 429 Port)                                                                                                                                                | Speed = Low<br>Data = GAMA Format 1<br>or<br>Speed = Low<br>Data = GARMIN 429<br>(Only used when VNAV function is enabled and one of the following:<br>when GTN has software version 6.50 or later, when a GTN Xi is installed) |



| Config Page                                                                                                                                                                             | Config Option                                                    | Configuration Setting                                                                                               |
|-----------------------------------------------------------------------------------------------------------------------------------------------------------------------------------------|------------------------------------------------------------------|---------------------------------------------------------------------------------------------------------------------|
|                                                                                                                                                                                         | ARINC 429 Out (x)<br>(x represents any available ARINC 429 Port) | Speed = Low<br>Data = ARINC 429                                                                                     |
|                                                                                                                                                                                         | SDI                                                              | LNAV1 (If GTN (Xi) is #1 navigator)<br>Or<br>LNAV2 (If GTN (Xi) is #2 navigator)                                    |
| <b>RS-232</b>                                                                                                                                                                           | RS-232 (x)<br>(x represents any available RS-232 Port )          | Output = MapMX Format 1                                                                                             |
| <b>Main Indicator (Analog) Configuration</b>                                                                                                                                            | CDI Key                                                          | Enabled                                                                                                             |
|                                                                                                                                                                                         | Selected Course for GPS                                          | Allowed                                                                                                             |
|                                                                                                                                                                                         | Selected Course for VLOC                                         | Allowed                                                                                                             |
|                                                                                                                                                                                         | V-Flag State                                                     | Normal                                                                                                              |
| <b>VOR/LOC/GS Configuration</b>                                                                                                                                                         | Nav Radio                                                        | Enabled (7)                                                                                                         |
|                                                                                                                                                                                         | ARINC 429 Configuration                                          | Tx Speed = Low<br>SDI =<br>VOR/ILS 1 (If GTN (Xi) is #1 navigator)<br>Or<br>VOR/ILS 2 (If GTN (Xi) is #2 navigator) |
| <b>Vertical Navigation Configuration</b><br>(Only used when VNAV function is enabled and one of the following: when GTN has software version 6.50 or later, when a GTN Xi is installed) | VNAV                                                             | Enabled                                                                                                             |
|                                                                                                                                                                                         | Transition to Approach                                           | Disabled                                                                                                            |
|                                                                                                                                                                                         | VDI Scale                                                        | 500Ft                                                                                                               |
| <b>Main System</b>                                                                                                                                                                      | Heading Source Input                                             | Not Connected<br>This selection is made only if the GTN being interfaced to has no other Heading input.             |
|                                                                                                                                                                                         | Altitude Source Input                                            | Connected<br>This selection is made only if the GTN being interfaced to has no other Altitude input.                |

#### 5.11.4 GNS 4XX(W) / 5XX(W) Configuration

| Config Page                             | Config Option                                                                                                                        | Configuration Setting                                                                                       |
|-----------------------------------------|--------------------------------------------------------------------------------------------------------------------------------------|-------------------------------------------------------------------------------------------------------------|
| <b>MAIN ARINC 429 CONFIG Page</b>       | IN (x)<br>(x represents any available ARINC 429 Port)                                                                                | Speed = Low<br>Data = GARMIN G5 (WAAS)<br>EFIS/Airdata (Non-WAAS)                                           |
|                                         | IN (x)<br>(x represents any available ARINC 429 Port)<br>(Only used with non-WAAS GNS <b>and</b> non-Garmin Autopilot is interfaced) | Speed = Low<br>Data = GAD 42<br>(Only used with non-WAAS GNS <b>and</b> non-Garmin Autopilot is interfaced) |
|                                         | OUT                                                                                                                                  | Speed = Low<br>Data = GAMA 429                                                                              |
|                                         | VNAV                                                                                                                                 | Enable Labels                                                                                               |
| <b>MAIN RS232 CONFIG Page</b>           | RS-232 (x)<br>(x represents any available RS-232 Channel)                                                                            | Input = OFF<br>Output = MapMX (WAAS)<br>AVIATION (Non WAAS)                                                 |
| <b>VOR/LOC/GS ARINC 429 CONFIG Page</b> | SPEED                                                                                                                                | RX = Low (7)<br>TX = Low                                                                                    |
|                                         | SDI                                                                                                                                  | VOR/ILS 1 (If GNS is #1 navigator) (7)<br>Or<br>VOR/ILS 2 (If GNS is #2 navigator) (7)                      |

#### 5.11.5 GNS 480 Configuration

| Config Page                   | Config Option                                         | Configuration Setting |
|-------------------------------|-------------------------------------------------------|-----------------------|
| <b>GND Maint Serial Setup</b> | CH (x)<br>(x represents any available Serial Channel) | Output = MapMX        |



| Config Page                               | Config Option                                             | Configuration Setting                                                                                           |
|-------------------------------------------|-----------------------------------------------------------|-----------------------------------------------------------------------------------------------------------------|
| <b>GND Maint ARINC 429 Setup</b>          | CH In (x)<br>(x represents any available ARINC 429 Port)  | SEL = EFIS<br>SPEED = Low<br>SDI =<br>SYS1 (If GNS is #1 navigator)<br>Or<br>SYS2 (If GNS is #2 navigator)      |
|                                           | CH Out (x)<br>(x represents any available ARINC 429 Port) | SEL = GAMA 429<br>SPEED = Low<br>SDI =<br>SYS1 (If GNS is #1 navigator)<br>Or<br>SYS2 (If GNS is #2 navigator)  |
|                                           | CH Out (x)<br>(x represents any available ARINC 429 Port) | SEL = VOR / ILS<br>SPEED = Low<br>SDI =<br>SYS1 (If GNS is #1 navigator)<br>Or<br>SYS2 (If GNS is #2 navigator) |
| <b>GND Maint Resolver Interface Setup</b> | Resolver                                                  | Not Installed                                                                                                   |
| <b>GND Maint Miscellaneous Setup</b>      | CDI Select                                                | Use                                                                                                             |

Note 1: Set configuration values and units to match the values indicated in the appropriate AFM and document settings in the space provided.

Note 2: If the aircraft has no AFM set the values as determined by the existing placards, instrument bugs or instrument markings.

Note 3: Existing placards related to airspeed limitations must be retained.

Note 4: Setting can remain at default setting, not supported in this configuration.

Note 5: The “Selected Course” will display when only one navigator is interfaced to the G5.

Note 6: “Selected Course 1” and “Selected Course 2” will display when dual navigators are interfaced.

Note 7: Not applicable to GPS navigators that has no VHF Navigation output. Reference Note 5 in Figure 5-13.

*This area intentionally blank*

## 5.12 G5 (ADI) with GPS/VHF Navigator

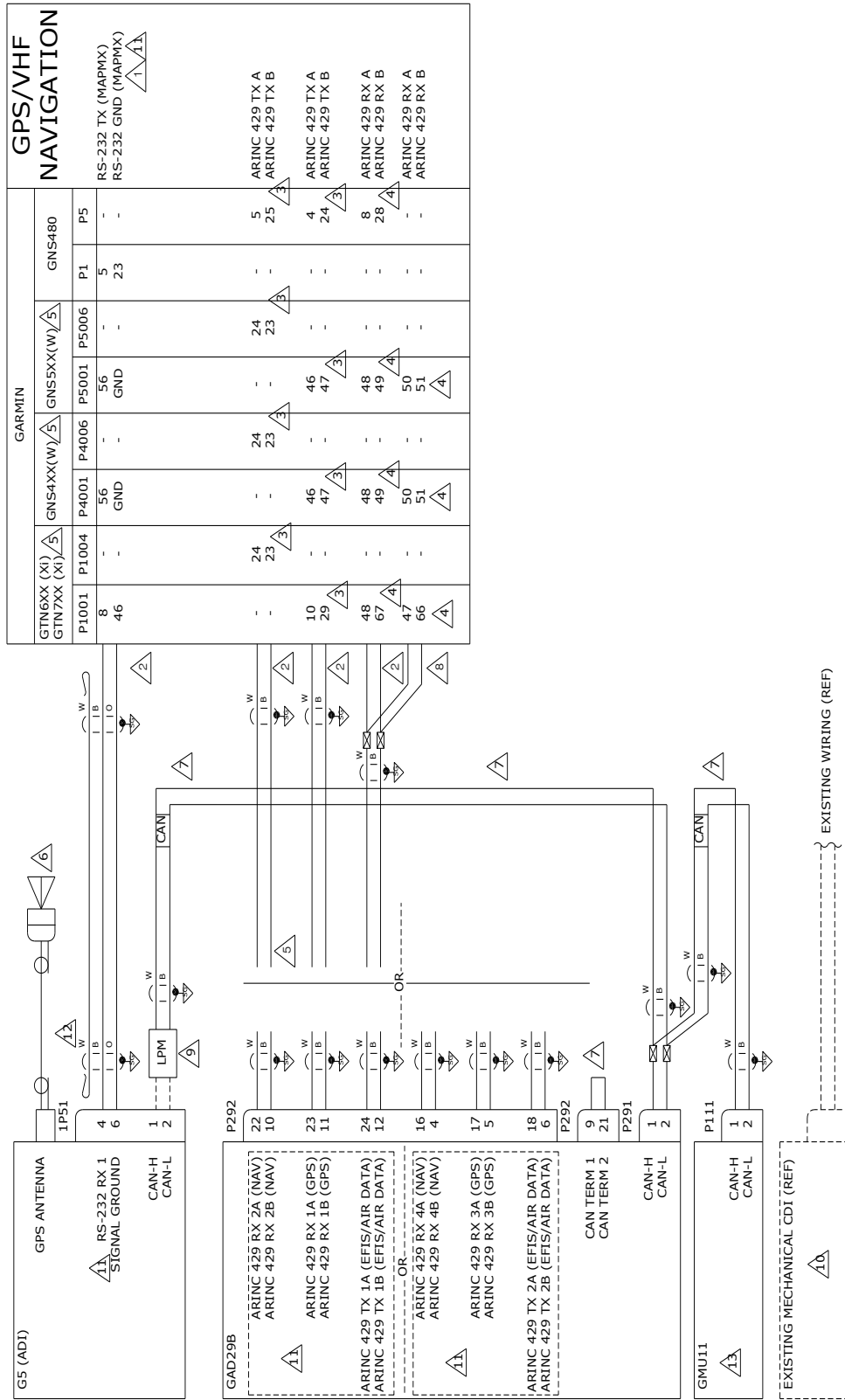















Figure 5-14 G5(ADI) with GPS/VHF Navigator

-  CONNECT TO AN APPROPRIATELY CONFIGURED, AVAILABLE RS-232 PORT.
-  IT IS ACCEPTABLE TO SPLICE WIRES TO EXISTING WIRING OR EXISTING WIRING MAY BE RE-USED IF WIRE LENGTH IS SUFFICIENT TO REACH G5/GAD29B. TERMINATE SHIELD GROUNDS TO CONNECTOR BACKSHELL. SHIELD LEADS MUST BE MAX 3.0 INCHES. REFER TO UNIT INSTALLATION MANUALS FOR MORE INFORMATION.
-  CONNECT TO ANY APPROPRIATELY CONFIGURED, AVAILABLE ARINC 429 TX PORT.
-  CONNECT TO ANY APPROPRIATELY CONFIGURED, AVAILABLE ARINC 429 RX PORT.
-  ARINC 429 TX (NAV) CONNECTION NOT APPLICABLE WHEN INTERFACING WITH GTN625/725 UNITS OR GNS4XX(W)/5XX(W) UNITS WITHOUT VHF NAVIGATION.
-  CONNECTION TO A GPS ANTENNA IS ONLY REQUIRED WHEN INTERFACED TO A NON WAAS UNIT. THE GLARE SHIELD MOUNTED GPS ANTENNA P/N 011-04036-00 REQUIRES A BNC/TNC ADAPTER P/N 330-01754-00 FOR CONNECTION TO THE G5.
-  CAN BUS LRUS MAY BE IN ANY ORDER ALONG BACKBONE AS LONG AS CAN BUS BACKBONE STRUCTURE GUIDELINES ARE FOLLOWED. REFER TO THE CAN BUS TERMINATION SECTION FOR FURTHER CAN BUS INFORMATION.
-  CONNECTION ONLY REQUIRED WHEN INTERFACING TO A NON-GARMIN AUTOPILOT AND ONE OF THE FOLLOWING:
  1. GNS IS NOT WAAS ENABLED
  2. GTN SOFTWARE IS V6.5 OR EARLIER
  3. GNS SOFTWARE IS V5.30 OR EARLIER
-  REFERENCE LIGHTNING PROTECTION MODULE (LPM) WIRING INTERFACE INTERCONNECT FOR DETAILED INSTALLATION REQUIREMENTS OF THE LPM.
-  EXISTING MECHANICAL CDI IS TO BE RETAINED FOR SINGLE G5 ADI INSTALLATIONS TO ALLOW A COURSE SETTING INPUT TO EXISTING NAVIGATORS.
-  IF INTERFACED WITH DUAL NAVIGATORS, CONNECT THE G5 RS-232 AND ONE SET OF ARINC 429 CONNECTIONS TO THE #1 NAVIGATOR. CONNECT THE #2 NAVIGATOR VIA ONE SET OF THE ARINC 429 CONNECTIONS. SEE CONFIGURATION TABLE FOR APPLICABLE CONFIGURATION SETTINGS.
-  IT IS ACCEPTABLE TO SPLICE THE MAPMX RS-232 TX WIRE AND GROUND WIRE WITH ANOTHER LRU THAT REQUIRES THESE CONNECTIONS.
-  GMU11 ONLY REQUIRED FOR A G5 INSTALLED IN THE DG POSITION. GMU11 IS OPTIONAL FOR A G5 INSTALLED IN THE ADI OR TURN COORDINATOR POSITION.

**Figure 5-15 G5 (ADI) with GPS/VHF Navigator Notes**

### 5.12.1 ADI Configuration

| Config Page                                                                         | Config Option                | Configuration Setting                                                                                         |
|-------------------------------------------------------------------------------------|------------------------------|---------------------------------------------------------------------------------------------------------------|
| <b>Device Information</b>                                                           | Installation Type            | Certified Instrument                                                                                          |
|                                                                                     | Diagnostics/Data Log         | Enabled                                                                                                       |
| <b>Attitude Configuration</b>                                                       | Indicator Type               | Normal                                                                                                        |
|                                                                                     | Pitch Display                | Normal                                                                                                        |
|                                                                                     | Roll Display                 | For Fixed Type Pointers G5 Config = Ground Pointer<br>or<br>For Movable Type Pointers G5 Config = Sky Pointer |
|                                                                                     | Standard Turn Roll Reference | Hide                                                                                                          |
|                                                                                     | Automatic Declutter          | Enabled                                                                                                       |
| <b>Air Data</b>                                                                     | Air Data Sensors             | Enabled                                                                                                       |
|                                                                                     | Outside Air Temp Sensor      | Enabled                                                                                                       |
|                                                                                     | Vertical Speed Indicator     | <b>Note: if a GAD 13 is not installed, select Disabled</b><br>(1)(2)                                          |
| <b>Airspeed</b><br><br><b>Note: Configure Units prior to setting<br/>airspeeds.</b> | VNE                          | (1)(2)(3)                                                                                                     |
|                                                                                     | VNO                          | (1)(2)(3)                                                                                                     |
|                                                                                     | VSO                          | (1)(2)(3)                                                                                                     |
|                                                                                     | VS1                          | (1)(2)(3)                                                                                                     |
|                                                                                     | VFE                          | (1)(2)(3)                                                                                                     |
|                                                                                     | VA                           | (1)(2)(3)                                                                                                     |
|                                                                                     | VX                           | (1)(2)(3)                                                                                                     |
| VY                                                                                  | (1)(2)(3)                    |                                                                                                               |





| Config Page            | Config Option              | Configuration Setting                                                                                                                                                                                                                                                              |
|------------------------|----------------------------|------------------------------------------------------------------------------------------------------------------------------------------------------------------------------------------------------------------------------------------------------------------------------------|
|                        | VG                         | (1)(2)(3)                                                                                                                                                                                                                                                                          |
|                        | VR                         | (1)(2)(3)                                                                                                                                                                                                                                                                          |
|                        | VMC                        | (1)(2)(3)                                                                                                                                                                                                                                                                          |
|                        | VYSE                       | (1)(2)(3)                                                                                                                                                                                                                                                                          |
| <b>Magnetometer</b>    | Magnetometer               | Enabled (if GMU 11 is connected)<br>Disabled (if GMU 11 is not connected)                                                                                                                                                                                                          |
|                        | Orientation                | Connector Aft<br>Or<br>Connector Forward<br>Or<br>Connector Port<br>Or<br>Connector Starboard                                                                                                                                                                                      |
| <b>Flight Controls</b> | Garmin Autopilot Servos    | None                                                                                                                                                                                                                                                                               |
|                        | Analog Autopilot Interface | None<br>Or<br>See Section 5.24 if a Non-Garmin Autopilot is interfaced                                                                                                                                                                                                             |
| <b>Backlight</b>       | Current Mode               | Automatic                                                                                                                                                                                                                                                                          |
|                        | Default Mode               | Automatic                                                                                                                                                                                                                                                                          |
|                        | Minimum Photocell Input    | Default                                                                                                                                                                                                                                                                            |
|                        | Minimum Display Brightness | Default                                                                                                                                                                                                                                                                            |
|                        | Maximum Photocell Input    | Default                                                                                                                                                                                                                                                                            |
|                        | Maximum Display Brightness | Default                                                                                                                                                                                                                                                                            |
| <b>Display</b>         | Filter Time Constant       | Default                                                                                                                                                                                                                                                                            |
|                        | HSI Page                   | Disabled                                                                                                                                                                                                                                                                           |
| <b>Battery</b>         | Power Up Page              | PFD                                                                                                                                                                                                                                                                                |
|                        | Show Battery Status        | When Using Battery                                                                                                                                                                                                                                                                 |
| <b>GPS</b>             | Automatic Power Off        | On Ground Only                                                                                                                                                                                                                                                                     |
|                        | Internal GPS Receiver      | Disabled (WAAS Units)<br>Enabled (Non WAAS Units<br>or G5 is connected to GPS antenna)                                                                                                                                                                                             |
| <b>Navigation</b>      | GPS Data Fields            | Show                                                                                                                                                                                                                                                                               |
|                        | Navigation Data            | Enabled<br><b>Note: If an autopilot interface is configured, this configuration page is set to ENABLED by default.</b>                                                                                                                                                             |
|                        | Selected Course            | Enabled (5)                                                                                                                                                                                                                                                                        |
|                        | Selected Course 1          | Enabled (6)                                                                                                                                                                                                                                                                        |
| <b>Units</b>           | Selected Course 2          | Enabled (6)                                                                                                                                                                                                                                                                        |
|                        | VNAV Deviation Scale       | (4)                                                                                                                                                                                                                                                                                |
|                        | Altitude                   | (1)(2)                                                                                                                                                                                                                                                                             |
|                        | Distance                   | (1)(2)                                                                                                                                                                                                                                                                             |
|                        | Airspeed                   | (1)(2)(3)                                                                                                                                                                                                                                                                          |
|                        | Ground Speed               | (1)(2)                                                                                                                                                                                                                                                                             |
| <b>RS-232</b>          | Navigation Angle           | Magnetic                                                                                                                                                                                                                                                                           |
|                        | Vertical Speed             | (1)(2)                                                                                                                                                                                                                                                                             |
|                        | Pressure                   | (1)(2)                                                                                                                                                                                                                                                                             |
|                        | Input Format               | MapMx (WAAS Units)<br>AVIATION (Non WAAS Units)                                                                                                                                                                                                                                    |
| <b>ARINC 429</b>       | Output Format              | None                                                                                                                                                                                                                                                                               |
|                        | Output 1                   | EFIS / AIRDATA 1 (SDI 1)<br>(Only used with GTN 6XX / 7XX (Xi) and GNS 4XX(W) / 5XX(W) with <b>no</b> autopilot or Garmin autopilot interfaced)<br>EFIS / AIRDATA 2 (SDI 1)<br>(Always used with GTN 6XX/7XX (Xi) and GNS 4XX(W) / 5XX(W) when Non-Garmin Autopilot is interfaced) |



| Config Page                    | Config Option | Configuration Setting                                                                                                                         |
|--------------------------------|---------------|-----------------------------------------------------------------------------------------------------------------------------------------------|
|                                | Output 2      | EFIS / AIRDATA 1 (SDI 2)<br>(Only used with GTN 6XX/7XX (Xi) and GNS 4XX(W) / 5XX(W) with <b>no</b> autopilot or Garmin autopilot interfaced) |
|                                |               | EFIS / AIRDATA 2 (SDI 2)<br>(Always used with GTN 6XX/7XX (Xi) and GNS 4XX(W) / 5XX(W) when Non-Garmin Autopilot is interfaced)               |
|                                | Input 1       | Garmin GPS (SDI 1)<br>(If GTN (Xi) is #1 navigator)                                                                                           |
|                                | Input 2       | Garmin VOR/ILS (SDI 1) (7)<br>(If GTN (Xi) is #1 navigator)                                                                                   |
|                                | Input 3       | Garmin GPS (SDI 2)<br>(If GTN (Xi) is #2 navigator)                                                                                           |
|                                | Input 4       | Garmin VOR/ILS (SDI 2) (7)<br>(If GTN (Xi) is #2 navigator)                                                                                   |
| <b>Exit Configuration Mode</b> |               |                                                                                                                                               |

### 5.12.2 GTN 6XX/7XX (Xi) Configuration

| Config Page                                                                                                                                                                                | Config Option                                                                                                                                                                                                   | Configuration Setting                                                                                                                                                                                                           |
|--------------------------------------------------------------------------------------------------------------------------------------------------------------------------------------------|-----------------------------------------------------------------------------------------------------------------------------------------------------------------------------------------------------------------|---------------------------------------------------------------------------------------------------------------------------------------------------------------------------------------------------------------------------------|
| <b>ARINC 429</b>                                                                                                                                                                           | ARINC 429 In (x)<br>(x represents any available ARINC 429 Port )                                                                                                                                                | Speed = Low<br>Data = EFIS Format 2                                                                                                                                                                                             |
|                                                                                                                                                                                            | ARINC 429 In (x)<br>(x represents any available ARINC 429 Port)<br>(Only used when Non-Garmin Autopilot is interfaced and installed GTN software version is prior to V6.60, GTN Xi does not require this input) | Speed = Low<br>Data = GAD Format 1<br>(Only used when Non-Garmin Autopilot is Interfaced and installed GTN software version is prior to V6.60, GTN Xi does not require this input)                                              |
|                                                                                                                                                                                            | ARINC 429 Out (x)<br>(x represents any available ARINC 429 Port)                                                                                                                                                | Speed = Low<br>Data = GAMA Format 1<br>or<br>Speed = Low<br>Data = GARMIN 429<br>(Only used when VNAV function is enabled and one of the following:<br>when GTN has software version 6.50 or later, when a GTN Xi is installed) |
|                                                                                                                                                                                            | ARINC 429 Out (x)<br>(x represents any available ARINC 429 Port)                                                                                                                                                | Speed = Low<br>Data = ARINC 429                                                                                                                                                                                                 |
|                                                                                                                                                                                            | SDI                                                                                                                                                                                                             | LNAV1 (If GTN (Xi) is #1 navigator)<br>Or<br>LNAV2 (If GTN (Xi) is #2 navigator)                                                                                                                                                |
|                                                                                                                                                                                            |                                                                                                                                                                                                                 |                                                                                                                                                                                                                                 |
| <b>RS-232</b>                                                                                                                                                                              | RS-232 (x)<br>(x represents any available RS-232 Port)                                                                                                                                                          | Output = MapMX Format 1                                                                                                                                                                                                         |
| <b>Main Indicator (Analog) Configuration</b>                                                                                                                                               | CDI Key                                                                                                                                                                                                         | Enabled                                                                                                                                                                                                                         |
|                                                                                                                                                                                            | Selected Course for GPS                                                                                                                                                                                         | Allowed                                                                                                                                                                                                                         |
|                                                                                                                                                                                            | Selected Course for VLOC                                                                                                                                                                                        | Allowed                                                                                                                                                                                                                         |
|                                                                                                                                                                                            | V-Flag State                                                                                                                                                                                                    | Normal                                                                                                                                                                                                                          |
| <b>VOR/LOC/GS Configuration</b>                                                                                                                                                            | Nav Radio                                                                                                                                                                                                       | Enabled (7)                                                                                                                                                                                                                     |
|                                                                                                                                                                                            | ARINC 429 Configuration                                                                                                                                                                                         | Tx Speed = Low<br>SDI =<br>VOR/ILS 1 (If GTN (Xi) is #1 navigator)<br>Or<br>VOR/ILS 2 (If GTN (Xi) is #2 navigator)                                                                                                             |
| <b>Vertical Navigation Configuration</b><br>(Only used when VNAV function is enabled and one of the following:<br>when GTN has software version 6.50 or later, when a GTN Xi is installed) | VNAV                                                                                                                                                                                                            | Enabled                                                                                                                                                                                                                         |
|                                                                                                                                                                                            | Transition to Approach                                                                                                                                                                                          | Disabled                                                                                                                                                                                                                        |
|                                                                                                                                                                                            | VDI Scale                                                                                                                                                                                                       | 500Ft                                                                                                                                                                                                                           |
| <b>Exit Configuration Mode</b>                                                                                                                                                             |                                                                                                                                                                                                                 |                                                                                                                                                                                                                                 |



| Config Page | Config Option         | Configuration Setting                                                                                   |
|-------------|-----------------------|---------------------------------------------------------------------------------------------------------|
| Main System | Heading Source Input  | Not Connected<br>This selection is made only if the GTN being interfaced to has no other Heading input. |
|             | Altitude Source Input | Connected<br>This selection is made only if the GTN being interfaced to has no other Altitude input.    |

### 5.12.3 GNS 4XX(W)/5XX(W) Configuration

| Config Page                      | Config Option                                                                                                                 | Configuration Setting                                                                                |
|----------------------------------|-------------------------------------------------------------------------------------------------------------------------------|------------------------------------------------------------------------------------------------------|
| MAIN ARINC 429 CONFIG Page       | IN (x)<br>(x represents any available ARINC 429 Port)                                                                         | Speed = Low<br>Data = GARMIN G5 (WAAS)<br>EFIS/Airdata (Non-WAAS)                                    |
|                                  | IN (x)<br>(x represents any available ARINC 429 Port)<br>(Only used with non-WAAS GNS and non-Garmin Autopilot is interfaced) | Speed = Low<br>Data = GAD 42<br>(Only used with non-WAAS GNS and non-Garmin Autopilot is interfaced) |
|                                  | OUT                                                                                                                           | Speed = Low<br>Data = GAMA 429                                                                       |
|                                  | VNAV                                                                                                                          | Enable Labels                                                                                        |
| MAIN RS232 CONFIG Page           | RS-232 (x)<br>(x represents any available RS-232 Channel )                                                                    | Input = OFF<br>Output = MapMX (WAAS)<br>AVIATION (Non WAAS)                                          |
| VOR/LOC/GS ARINC 429 CONFIG Page | SPEED                                                                                                                         | RX = Low (7)<br>TX = Low                                                                             |
|                                  | SDI                                                                                                                           | VOR/ILS 1 (If GNS is #1 navigator) (7)<br>Or<br>VOR/ILS 2 (If GNS is #2 navigator) (7)               |

### 5.12.4 GNS 480 Configuration

| Config Page                        | Config Option                                             | Configuration Setting                                                                                           |
|------------------------------------|-----------------------------------------------------------|-----------------------------------------------------------------------------------------------------------------|
| GND Maint Serial Setup             | CH (x)<br>(x represents any available Serial Channel)     | Output = MapMX                                                                                                  |
| GND Maint ARINC 429 Setup          | CH In (x)<br>(x represents any available ARINC 429 Port)  | SEL = EFIS<br>SPEED = Low<br>SDI =<br>SYS1 (If GNS is #1 navigator)<br>Or<br>SYS2 (If GNS is #2 navigator)      |
|                                    | CH Out (x)<br>(x represents any available ARINC 429 Port) | SEL = GAMA 429<br>SPEED = Low<br>SDI =<br>SYS1 (If GNS is #1 navigator)<br>Or<br>SYS2 (If GNS is #2 navigator)  |
|                                    | CH Out (x)<br>(x represents any available ARINC 429 Port) | SEL = VOR / ILS<br>SPEED = Low<br>SDI =<br>SYS1 (If GNS is #1 navigator)<br>Or<br>SYS2 (If GNS is #2 navigator) |
| GND Maint Resolver Interface Setup | Resolver                                                  | Not Installed                                                                                                   |
| GND Maint Miscellaneous Setup      | CDI Select                                                | Use                                                                                                             |

Note 1: Set configuration values and units to match the values indicated in the appropriate AFM and document settings in the space provided.



Note 2: If the aircraft has no AFM set the values as determined by the existing placards, instrument bugs or instrument markings.

Note 3: Existing placards related to airspeed limitations must be retained.

Note 4: Setting can remain at default setting, not supported in this configuration.

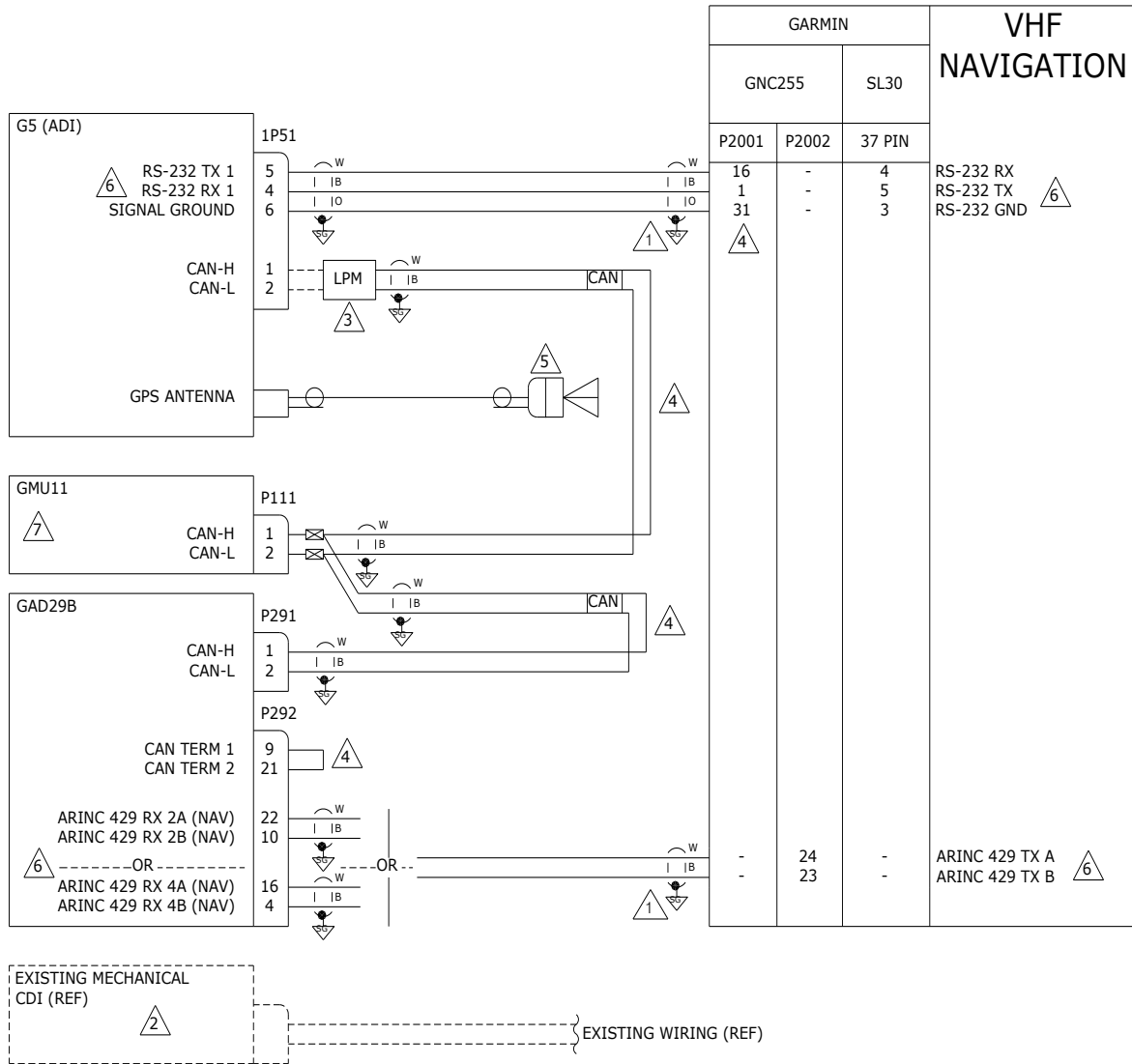
Note 5: The “Selected Course” will display when only one navigator is interfaced to the G5.

Note 6: “Selected Course 1” and “Selected Course 2” will display when dual navigators are interfaced.

Note 7: Not applicable to GPS navigators that has no VHF Navigation output. Reference Note 5 in Figure 5-13.

*This area intentionally blank*

## 5.13 G5 (ADI) with VHF Navigator



- 1 IT IS ACCEPTABLE TO SPLICE WIRES TO EXISTING WIRING OR EXISTING WIRING MAY BE RE-USED IF WIRE LENGTH IS SUFFICIENT TO REACH G5/GAD29B. TERMINATE SHIELD GROUNDS TO CONNECTOR BACKSHELL. SHIELD LEADS MUST BE MAX 3.0 INCHES. REFER TO UNIT INSTALLATION MANUALS FOR MORE INFORMATION.
- 2 EXISTING MECHANICAL CDI IS TO BE RETAINED FOR SINGLE G5 ADI INSTALLATIONS TO ALLOW A COURSE SETTING INPUT TO EXISTING NAVIGATORS.
- 3 REFERENCE LIGHTNING PROTECTION MODULE (LPM) WIRING INTERFACE INTERCONNECT FOR DETAILED INSTALLATION REQUIREMENTS OF THE LPM.
- 4 CAN BUS LRUS MAY BE IN ANY ORDER ALONG BACKBONE AS LONG AS CAN BUS BACKBONE STRUCTURE GUIDELINES ARE FOLLOWED. REFER TO THE CAN BUS TERMINATION SECTION FOR FURTHER CAN BUS INFORMATION.
- 5 THE GLARE SHIELD MOUNTED GPS ANTENNA P/N 011-04036-00 REQUIRES A BNC/TNC ADAPTER P/N 330-01754-00 FOR CONNECTION TO THE G5.
- 6 IF INTERFACED WITH DUAL NAVIGATORS, CONNECT THE G5 RS-232 AND ONE SET OF ARINC 429 CONNECTIONS TO THE #1 NAVIGATOR. CONNECT THE #2 NAVIGATOR VIA ONE SET OF THE ARINC 429 CONNECTIONS. SEE CONFIGURATION TABLE FOR APPLICABLE CONFIGURATION SETTINGS.
- 7 GMU11 ONLY REQUIRED FOR A G5 INSTALLED IN THE DG POSITION. GMU11 IS OPTIONAL FOR A G5 INSTALLED IN THE ADI OR TURN COORDINATOR POSITION.

**Figure 5-16 G5 (ADI) with VHF Navigator**



### 5.13.1 ADI Configuration

| Config Page                                                       | Config Option                | Configuration Setting                                                                                         |
|-------------------------------------------------------------------|------------------------------|---------------------------------------------------------------------------------------------------------------|
| Device Information                                                | Installation Type            | Certified Instrument                                                                                          |
|                                                                   | Diagnostics/Data Log         | Enabled                                                                                                       |
| Attitude Configuration                                            | Indicator Type               | Normal                                                                                                        |
|                                                                   | Pitch Display                | Normal                                                                                                        |
|                                                                   | Roll Display                 | For Fixed Type Pointers G5 Config = Ground Pointer<br>or<br>For Movable Type Pointers G5 Config = Sky Pointer |
|                                                                   | Standard Turn Roll Reference | Hide                                                                                                          |
|                                                                   | Automatic Declutter          | Enabled                                                                                                       |
| Air Data                                                          | Air Data Sensors             | Enabled                                                                                                       |
|                                                                   | Outside Air Temp Sensor      | Enabled<br><b>Note: if a GAD 13 is not installed, select Disabled</b>                                         |
|                                                                   | Vertical Speed Indicator     | (1)(2)                                                                                                        |
| Airspeed<br><br>Note: Configure Units prior to setting airspeeds. | VNE                          | (1)(2)(3)                                                                                                     |
|                                                                   | VNO                          | (1)(2)(3)                                                                                                     |
|                                                                   | VSO                          | (1)(2)(3)                                                                                                     |
|                                                                   | VS1                          | (1)(2)(3)                                                                                                     |
|                                                                   | VFE                          | (1)(2)(3)                                                                                                     |
|                                                                   | VA                           | (1)(2)(3)                                                                                                     |
|                                                                   | VX                           | (1)(2)(3)                                                                                                     |
|                                                                   | VY                           | (1)(2)(3)                                                                                                     |
|                                                                   | VG                           | (1)(2)(3)                                                                                                     |
|                                                                   | VR                           | (1)(2)(3)                                                                                                     |
|                                                                   | VMC                          | (1)(2)(3)                                                                                                     |
| VYSE                                                              | (1)(2)(3)                    |                                                                                                               |
| Magnetometer                                                      | Magnetometer                 | Enabled (if GMU 11 is connected)<br>Disabled (if GMU 11 is not connected)                                     |
|                                                                   | Orientation                  | Connector Aft<br>Or<br>Connector Forward<br>Or<br>Connector Port<br>Or<br>Connector Starboard                 |
| Flight Controls                                                   | Garmin Autopilot Servos      | None                                                                                                          |
|                                                                   | Analog Autopilot Interface   | None<br>Or<br>See Section 5.24 if a Non-Garmin Autopilot is interfaced                                        |
| Backlight                                                         | Current Mode                 | Automatic                                                                                                     |
|                                                                   | Default Mode                 | Automatic                                                                                                     |
|                                                                   | Minimum Photocell Input      | Default                                                                                                       |
|                                                                   | Minimum Display Brightness   | Default                                                                                                       |
|                                                                   | Maximum Photocell Input      | Default                                                                                                       |
|                                                                   | Maximum Display Brightness   | Default                                                                                                       |
|                                                                   | Filter Time Constant         | Default                                                                                                       |
| Display                                                           | HSI Page                     | Disabled                                                                                                      |
|                                                                   | Power Up Page                | PFD                                                                                                           |
| Battery                                                           | Show Battery Status          | When Using Battery                                                                                            |
|                                                                   | Automatic Power Off          | On Ground Only                                                                                                |
| GPS                                                               | Internal GPS Receiver        | Enabled                                                                                                       |
|                                                                   | GPS Data Fields              | Show                                                                                                          |



| Config Page                    | Config Option        | Configuration Setting                                                                                                                                            |
|--------------------------------|----------------------|------------------------------------------------------------------------------------------------------------------------------------------------------------------|
| <b>Navigation</b>              | Navigation Data      | Disabled<br><b>Note: Only used if an autopilot is configured. If an autopilot interface is configured, this configuration page is set to ENABLED by default.</b> |
|                                | Selected Course      | Enabled (5)                                                                                                                                                      |
|                                | Selected Course 1    | Enabled (6)                                                                                                                                                      |
|                                | Selected Course 2    | Enabled (6)                                                                                                                                                      |
|                                | VNAV Deviation Scale | (4)                                                                                                                                                              |
| <b>Units</b>                   | Altitude             | (1)(2)                                                                                                                                                           |
|                                | Distance             | (1)(2)                                                                                                                                                           |
|                                | Airspeed             | (1)(2)(3)                                                                                                                                                        |
|                                | Vertical Speed       | (1)(2)                                                                                                                                                           |
|                                | Pressure             | (1)(2)                                                                                                                                                           |
| <b>RS-232</b>                  | Input Format         | Garmin VHF NAV Radio                                                                                                                                             |
|                                | Output Format        | Garmin VHF NAV Radio                                                                                                                                             |
| <b>ARINC 429</b>               | Output 1             | None                                                                                                                                                             |
|                                | Output 2             | None                                                                                                                                                             |
|                                | Input 1              | Garmin VOR/ILS (SDI 1)<br>(If GNC is #1 Navigator)                                                                                                               |
|                                | Input 2              | None                                                                                                                                                             |
|                                | Input 3              | Garmin VOR/ILS (SDI 2)<br>(If GNC is #2 Navigator)                                                                                                               |
|                                | Input 4              | None                                                                                                                                                             |
| <b>Exit Configuration Mode</b> |                      |                                                                                                                                                                  |

### 5.13.2 GNC 255 Configuration

| Config Page              | Config Option      | Configuration Setting                                                                                  |
|--------------------------|--------------------|--------------------------------------------------------------------------------------------------------|
| <b>Sys Configuration</b> | RS 232 Serial Port | IO Mode = NMEA                                                                                         |
| <b>NAV Configuration</b> | CDI Indicator      | Serial (If GNC255 is installed as #1 navigator)<br>Or<br>None (If GNC255 is installed as #2 navigator) |
|                          | ARINC 429          | Tx = Low<br>SDI =<br>VOR/ILS 1 (If GNC is #1 Navigator)<br>Or<br>VOR/ILS 2 (If GNC is #2 Navigator)    |

### 5.13.3 SL30 Configuration

| Config Page                   | Config Option      | Configuration Setting |
|-------------------------------|--------------------|-----------------------|
| <b>Sys Configuration</b>      | RS 232 Serial Port | No Setting            |
| <b>Attitude Configuration</b> | Indicator Type     | TYPE = Serial         |

Note 1: Set configuration values and units to match the values indicated in the appropriate AFM and document settings in the space provided.

Note 2: If the aircraft has no AFM set the values as determined by the existing placards, instrument bugs or instrument markings.

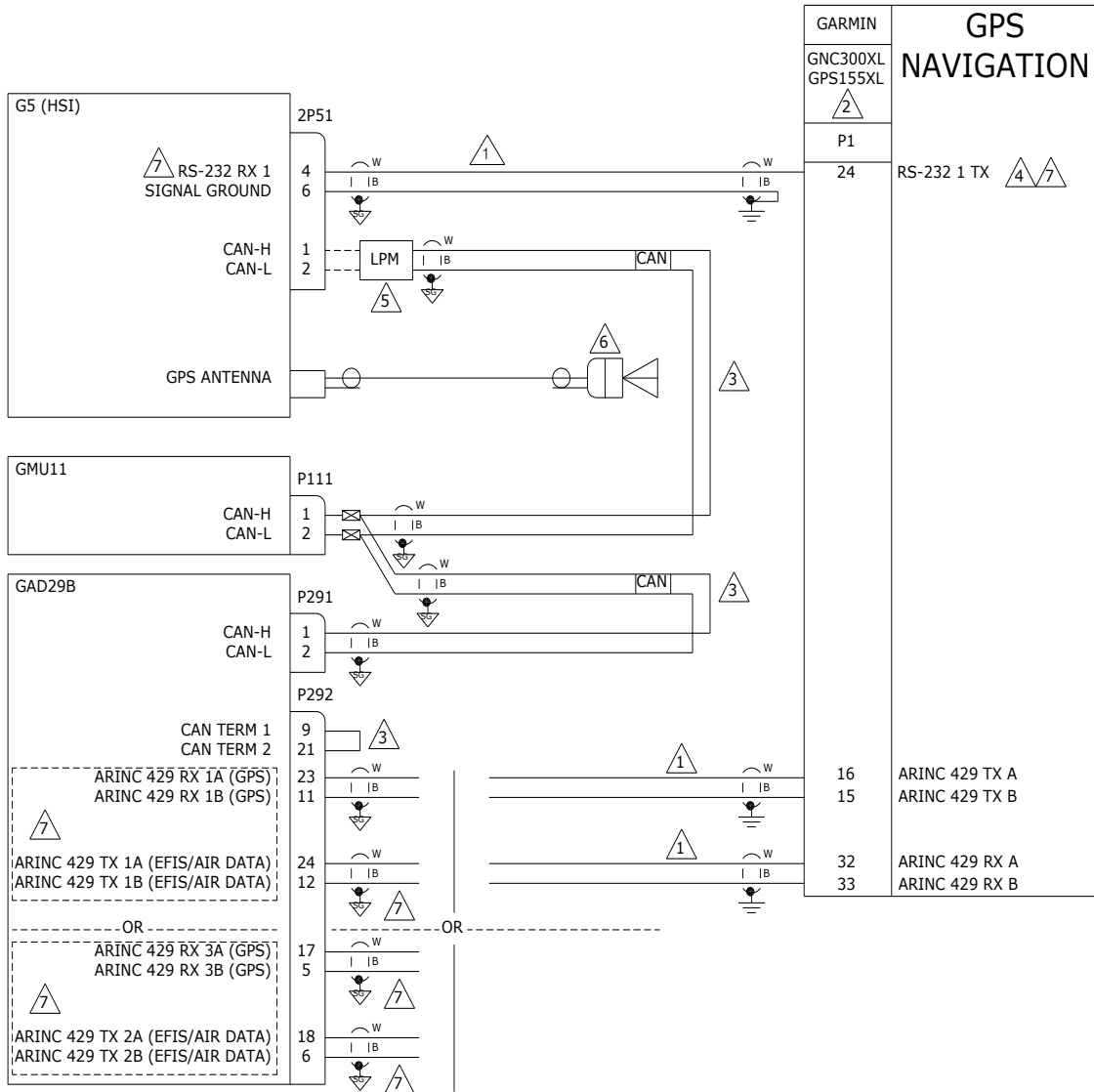
Note 3: Existing placards related to airspeed limitations must be retained.

Note 4: Setting can remain at default setting, not supported in this configuration.

Note 5: The “Selected Course” will display when only one navigator is interfaced to the G5.

Note 6: “Selected Course 1” and “Selected Course 2” will display when dual navigators are interfaced.

## 5.14 G5 (HSI) with GPS Navigator



- 1 IT IS ACCEPTABLE TO SPLICE WIRES TO EXISTING WIRING OR EXISTING WIRING MAY BE RE-USED IF WIRE LENGTH IS SUFFICIENT TO REACH G5/GAD29B. SHIELD LEADS MUST BE MAX 3.0 INCHES. REFER TO UNIT INSTALLATION MANUALS FOR MORE INFORMATION.
- 2 THIS STC DOES NOT APPROVE A CDI INTERFACED WITH THE SAME NAVIGATOR AS THE G5. REMOVE ANY EXISTING CDI INTERFACED WITH THIS NAVIGATOR.
- 3 CAN BUS LRUS MAY BE IN ANY ORDER ALONG BACKBONE AS LONG AS CAN BUS BACKBONE STRUCTURE GUIDELINES ARE FOLLOWED. REFER TO THE CAN BUS TERMINATION SECTION FOR FURTHER CAN BUS INFORMATION.
- 4 CONNECT TO ANY APPROPRIATELY CONFIGURED, AVAILABLE RS-232 PORT.
- 5 REFERENCE LIGHTNING PROTECTION MODULE (LPM) WIRING INTERFACE INTERCONNECT FOR DETAILED INSTALLATION REQUIREMENTS OF THE LPM.
- 6 CONNECTION TO A GPS ANTENNA REQUIRED. THE GPS155XL/GNC300XL ARE NON WAAS UNITS. THE GLARE SHIELD MOUNTED GPS ANTENNA P/N 011-04036-00 REQUIRES A BNC/TNC ADAPTER P/N 330-01754-00 FOR CONNECTION TO THE G5.
- 7 IF INTERFACED WITH DUAL NAVIGATORS, CONNECT THE G5 RS-232 AND ONE SET OF ARINC 429 CONNECTIONS TO THE #1 NAVIGATOR. CONNECT THE #2 NAVIGATOR VIA ONE SET OF THE ARINC 429 CONNECTIONS. SEE CONFIGURATION TABLE FOR APPLICABLE CONFIGURATION SETTINGS.

**Figure 5-17 G5 (HSI) with GPS Navigator**





## 5.14.1 HSI Configuration

| Config Page                                                                  | Config Option                | Configuration Setting                                                                                         |
|------------------------------------------------------------------------------|------------------------------|---------------------------------------------------------------------------------------------------------------|
| Device Information                                                           | Installation Type            | Certified Instrument                                                                                          |
|                                                                              | Diagnostics/Data Log         | Enabled                                                                                                       |
| Attitude Configuration                                                       | Indicator Type               | Normal                                                                                                        |
|                                                                              | Pitch Display                | Normal                                                                                                        |
|                                                                              | Roll Display                 | For Fixed Type Pointers G5 Config = Ground Pointer<br>or<br>For Movable Type Pointers G5 Config = Sky Pointer |
|                                                                              | Standard Turn Roll Reference | Hide                                                                                                          |
|                                                                              | Automatic Declutter          | Enabled                                                                                                       |
| Air Data                                                                     | Air Data Sensors             | Enabled                                                                                                       |
|                                                                              | Outside Air Temp Sensor      | Enabled<br><b>Note: if a GAD 13 is not installed, select Disabled</b>                                         |
|                                                                              | Vertical Speed Indicator     | (1)(2)                                                                                                        |
| Airspeed<br><br><b>Note: Configure Units prior to setting<br/>airspeeds.</b> | VNE                          | (1)(2)(3)                                                                                                     |
|                                                                              | VNO                          | (1)(2)(3)                                                                                                     |
|                                                                              | VSO                          | (1)(2)(3)                                                                                                     |
|                                                                              | VS1                          | (1)(2)(3)                                                                                                     |
|                                                                              | VFE                          | (1)(2)(3)                                                                                                     |
|                                                                              | VA                           | (1)(2)(3)                                                                                                     |
|                                                                              | VX                           | (1)(2)(3)                                                                                                     |
|                                                                              | VY                           | (1)(2)(3)                                                                                                     |
|                                                                              | VG                           | (1)(2)(3)                                                                                                     |
|                                                                              | VR                           | (1)(2)(3)                                                                                                     |
|                                                                              | VMC                          | (1)(2)(3)                                                                                                     |
| VYSE                                                                         | (1)(2)(3)                    |                                                                                                               |
| Magnetometer                                                                 | Magnetometer                 | Enabled                                                                                                       |
|                                                                              | Orientation                  | Connector Aft<br>Or<br>Connector Forward<br>Or<br>Connector Port<br>Or<br>Connector Starboard                 |
| Flight Controls                                                              | Garmin Autopilot Servos      | None                                                                                                          |
|                                                                              | Analog Autopilot Interface   | None<br>Or<br>See Section 5.24 if a Non-Garmin Autopilot is interfaced                                        |
| Backlight                                                                    | Current Mode                 | Automatic                                                                                                     |
|                                                                              | Default Mode                 | Automatic                                                                                                     |
|                                                                              | Minimum Photocell Input      | Default                                                                                                       |
|                                                                              | Minimum Display Brightness   | Default                                                                                                       |
|                                                                              | Maximum Photocell Input      | Default                                                                                                       |
|                                                                              | Maximum Display Brightness   | Default                                                                                                       |
|                                                                              | Filter Time Constant         | Default                                                                                                       |
| Display                                                                      | HSI Page                     | Enabled                                                                                                       |
|                                                                              | Power Up Page                | HSI                                                                                                           |
| Battery                                                                      | Show Battery Status          | When Using Battery                                                                                            |
|                                                                              | Automatic Power Off          | On Ground Only                                                                                                |
| GPS                                                                          | Internal GPS Receiver        | Enabled                                                                                                       |
|                                                                              | GPS Data Fields              | Show                                                                                                          |



| Config Page             | Config Option        | Configuration Setting                                                                                                   |
|-------------------------|----------------------|-------------------------------------------------------------------------------------------------------------------------|
| Navigation              | Navigation Data      | Disabled<br><b>Note: If an autopilot interface is configured, this configuration page is set to ENABLED by default.</b> |
|                         | Selected Course      | Enabled (5)                                                                                                             |
|                         | Selected Course 1    | Enabled (6)                                                                                                             |
|                         | Selected Course 2    | Enabled (6)                                                                                                             |
|                         | VNAV Deviation Scale | (4)                                                                                                                     |
| Units                   | Altitude             | (1)(2)                                                                                                                  |
|                         | Distance             | (1)(2)                                                                                                                  |
|                         | Airspeed             | (1)(2)(3)                                                                                                               |
|                         | Ground Speed         | (1)(2)                                                                                                                  |
|                         | Navigation Angle     | Magnetic                                                                                                                |
|                         | Vertical Speed       | (1)(2)                                                                                                                  |
|                         | Pressure             | (1)(2)                                                                                                                  |
| RS-232                  | Input Format         | Aviation                                                                                                                |
|                         | Output Format        | None                                                                                                                    |
| ARINC 429               | Output 1             | EFIS / AIRDATA 1 (SDI 1)<br>(If GPS/GNC is installed as #1 navigator)                                                   |
|                         | Output 2             | EFIS / AIRDATA 1 (SDI 2)<br>(If GPS/GNC is installed as #2 navigator)                                                   |
|                         | Input 1              | Garmin GPS (Common)<br>(If GPS/GNC is installed as #1 navigator)                                                        |
|                         | Input 2              | None                                                                                                                    |
|                         | Input 3              | Garmin GPS (Common)<br>(If GPS/GNC is installed as #2 navigator)                                                        |
|                         | Input 4              | None                                                                                                                    |
| Exit Configuration Mode |                      |                                                                                                                         |

### 5.14.2 GNC 300XL / GPS 155XL Configuration

| Config Page             | Config Option   | Configuration Setting |
|-------------------------|-----------------|-----------------------|
| RS-232 Configuration    | CHANNEL1 IN     | Input = OFF           |
|                         | CHANNEL1 OUT    | Output = AVIATION     |
| ARINC 429 Configuration | ARINC 429 In 1  | Course/Heading        |
|                         | ARINC 429 Out 1 | KING EFS 40/50        |

Note 1: Set configuration values and units to match the values indicated in the appropriate AFM and document settings in the space provided.

Note 2: If the aircraft has no AFM set the values as determined by the existing placards, instrument bugs or instrument markings.

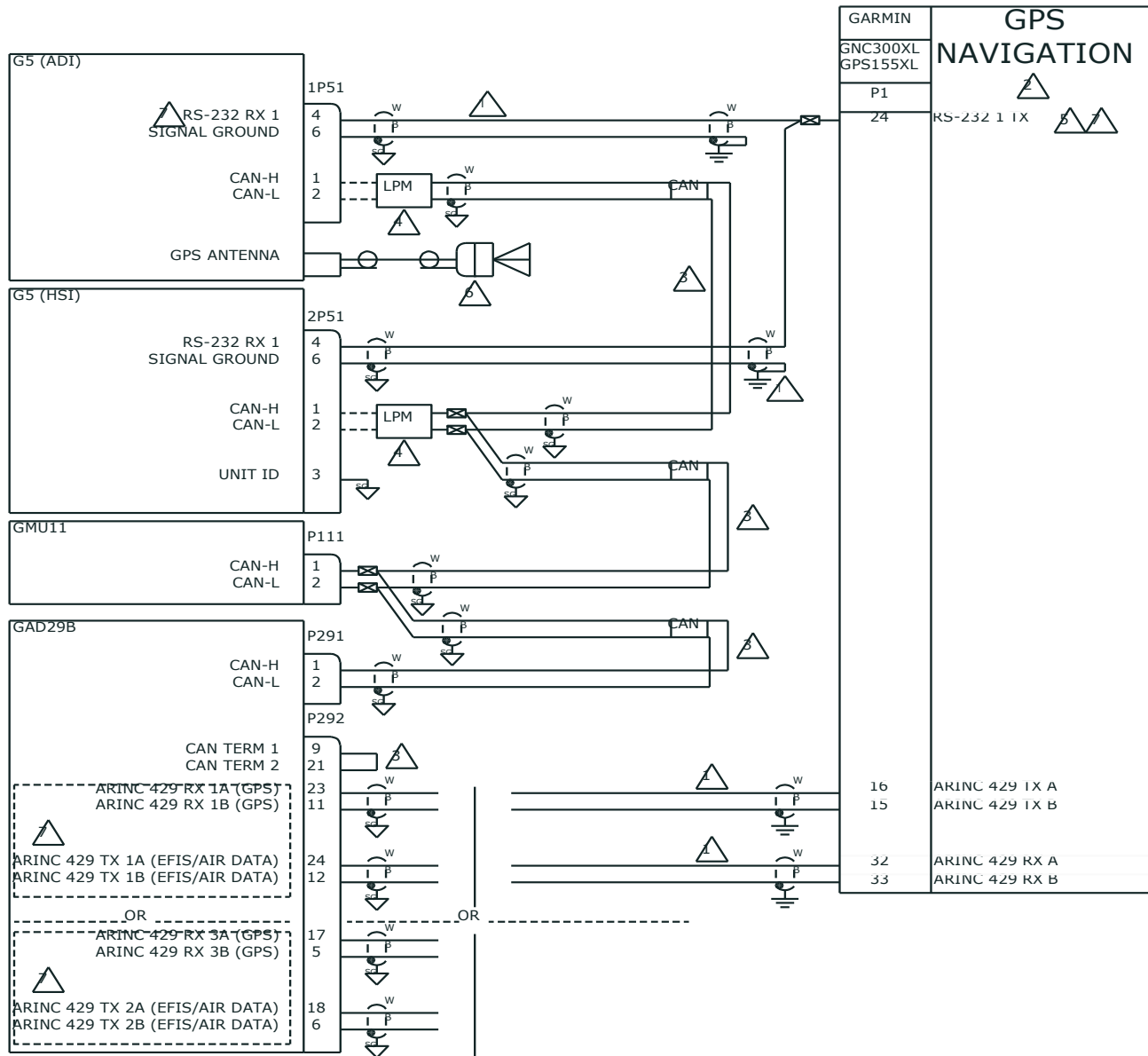
Note 3: Existing placards related to airspeed limitations must be retained.

Note 4: Setting can remain at default setting, not supported in this configuration.

Note 5: The “Selected Course” will display when only one navigator is interfaced to the G5.

Note 6: “Selected Course 1” and “Selected Course 2” will display when dual navigators are interfaced.

## 5.15 Dual G5 with GPS Navigator



- IT IS ACCEPTABLE TO SPLICE WIRES TO EXISTING WIRING OR EXISTING WIRING MAY BE RE-USED IF WIRE LENGTH IS SUFFICIENT TO REACH G5/GAD29B. SHIELD LEADS MUST BE MAX 3.0 INCHES. REFER TO UNIT INSTALLATION MANUALS FOR MORE INFORMATION.
- THIS STC DOES NOT APPROVE A CDI INTERFACED WITH THE SAME NAVIGATOR AS THE G5. REMOVE ANY EXISTING CDI INTERFACED WITH THIS NAVIGATOR.
- CAN BUS LRUS MAY BE IN ANY ORDER ALONG BACKBONE AS LONG AS CAN BUS BACKBONE STRUCTURE GUIDELINES ARE FOLLOWED. REFER TO THE CAN BUS TERMINATION SECTION FOR FURTHER CAN BUS INFORMATION.
- REFERENCE LIGHTNING PROTECTION MODULE (LPM) WIRING INTERFACE INTERCONNECT FOR DETAILED INSTALLATION REQUIREMENTS OF THE LPM.
- CONNECT TO ANY APPROPRIATELY CONFIGURED, AVAILABLE RS-232 PORT.
- CONNECTION TO A GPS ANTENNA REQUIRED. THE GPS155XL/GNC300XL ARE NON WAAS UNITS. THE GLARE SHIELD MOUNTED GPS ANTENNA P/N 011-04036-00 REQUIRES A BNC/TNC ADAPTER P/N 330-01754-00 FOR CONNECTION TO THE G5.
- IF INTERFACED WITH DUAL NAVIGATORS, CONNECT THE G5 RS-232 AND ONE SET OF ARINC 429 CONNECTIONS TO THE #1 NAVIGATOR. CONNECT THE #2 NAVIGATOR VIA ONE SET OF THE ARINC 429 CONNECTIONS. SEE CONFIGURATION TABLE FOR APPLICABLE CONFIGURATION SETTINGS.

**Figure 5-18 Dual G5 with GPS Navigator**



### 5.15.1 ADI Configuration

| Config Page                                                          | Config Option                | Configuration Setting                                                                                         |
|----------------------------------------------------------------------|------------------------------|---------------------------------------------------------------------------------------------------------------|
| Device Information                                                   | Installation Type            | Certified Instrument                                                                                          |
|                                                                      | Diagnostics/Data Log         | Enabled                                                                                                       |
| Attitude Configuration                                               | Indicator Type               | Normal                                                                                                        |
|                                                                      | Pitch Display                | Normal                                                                                                        |
|                                                                      | Roll Display                 | For Fixed Type Pointers G5 Config = Ground Pointer<br>or<br>For Movable Type Pointers G5 Config = Sky Pointer |
|                                                                      | Standard Turn Roll Reference | Hide                                                                                                          |
|                                                                      | Automatic Declutter          | Enabled                                                                                                       |
| Air Data                                                             | Air Data Sensors             | Enabled                                                                                                       |
|                                                                      | Outside Air Temp Sensor      | Enabled<br><b>Note: if a GAD 13 is not installed, select Disabled</b>                                         |
|                                                                      | Vertical Speed Indicator     | (1)(2)                                                                                                        |
| Airspeed<br><br>Note: Configure Units prior to setting<br>airspeeds. | VNE                          | (1)(2)(3)                                                                                                     |
|                                                                      | VNO                          | (1)(2)(3)                                                                                                     |
|                                                                      | VSO                          | (1)(2)(3)                                                                                                     |
|                                                                      | VS1                          | (1)(2)(3)                                                                                                     |
|                                                                      | VFE                          | (1)(2)(3)                                                                                                     |
|                                                                      | VA                           | (1)(2)(3)                                                                                                     |
|                                                                      | VX                           | (1)(2)(3)                                                                                                     |
|                                                                      | VY                           | (1)(2)(3)                                                                                                     |
|                                                                      | VG                           | (1)(2)(3)                                                                                                     |
|                                                                      | VR                           | (1)(2)(3)                                                                                                     |
| VMC                                                                  | (1)(2)(3)                    |                                                                                                               |
| VYSE                                                                 | (1)(2)(3)                    |                                                                                                               |
| Magnetometer                                                         | Magnetometer                 | Enabled                                                                                                       |
|                                                                      | Orientation                  | Connector Aft<br>Or<br>Connector Forward<br>Or<br>Connector Port<br>Or<br>Connector Starboard                 |
| Flight Controls                                                      | Garmin Autopilot Servos      | None                                                                                                          |
|                                                                      | Analog Autopilot Interface   | None<br>Or<br>See Section 5.24 if a Non-Garmin Autopilot is interfaced                                        |
| Backlight                                                            | Current Mode                 | Automatic                                                                                                     |
|                                                                      | Default Mode                 | Automatic                                                                                                     |
|                                                                      | Minimum Photocell Input      | Default                                                                                                       |
|                                                                      | Minimum Display Brightness   | Default                                                                                                       |
|                                                                      | Maximum Photocell Input      | Default                                                                                                       |
|                                                                      | Maximum Display Brightness   | Default                                                                                                       |
| Filter Time Constant                                                 | Default                      |                                                                                                               |
| Display                                                              | HSI Page                     | Disabled                                                                                                      |
|                                                                      | Power Up Page                | PFD                                                                                                           |
| Battery                                                              | Show Battery Status          | When Using Battery                                                                                            |
|                                                                      | Automatic Power Off          | On Ground Only                                                                                                |
| GPS                                                                  | Internal GPS Receiver        | Enabled                                                                                                       |
|                                                                      | GPS Data Fields              | Show                                                                                                          |



| Config Page             | Config Option        | Configuration Setting                                                                                                  |
|-------------------------|----------------------|------------------------------------------------------------------------------------------------------------------------|
| Navigation              | Navigation Data      | Enabled<br><b>Note: If an autopilot interface is configured, this configuration page is set to ENABLED by default.</b> |
|                         | Selected Course      | Enabled (5)                                                                                                            |
|                         | Selected Course 1    | Enabled (6)                                                                                                            |
|                         | Selected Course 2    | Enabled (6)                                                                                                            |
|                         | VNAV Deviation Scale | (4)                                                                                                                    |
| Units                   | Altitude             | (1)(2)                                                                                                                 |
|                         | Distance             | (1)(2)                                                                                                                 |
|                         | Airspeed             | (1)(2)(3)                                                                                                              |
|                         | Ground Speed         | (1)(2)                                                                                                                 |
|                         | Navigation Angle     | Magnetic                                                                                                               |
|                         | Vertical Speed       | (1)(2)                                                                                                                 |
|                         | Pressure             | (1)(2)                                                                                                                 |
| RS-232                  | Input Format         | AVIATION                                                                                                               |
|                         | Output Format        | None                                                                                                                   |
| ARINC 429               | Output 1             | EFIS / AIRDATA 1 (SDI 1)<br>(If GPS/GNC is installed as #1 navigator)                                                  |
|                         | Output 2             | EFIS / AIRDATA 1 (SDI 2)<br>(If GPS/GNC is installed as #2 navigator)                                                  |
|                         | Input 1              | Garmin GPS (Common)<br>(If GPS/GNC is installed as #1 navigator)                                                       |
|                         | Input 2              | None                                                                                                                   |
|                         | Input 3              | Garmin GPS (Common)<br>(If GPS/GNC is installed as #2 navigator)                                                       |
|                         | Input 4              | None                                                                                                                   |
| Exit Configuration Mode |                      |                                                                                                                        |

### 5.15.2 HSI Configuration

| Config Page             | Config Option              | Configuration Setting |
|-------------------------|----------------------------|-----------------------|
| Device Information      | Installation Type          | Certified Instrument  |
|                         | Diagnostics/Data Log       | Enabled               |
| Attitude Configuration  | Automatic Declutter        | Disabled              |
| Backlight               | Current Mode               | Automatic             |
|                         | Default Mode               | Automatic             |
|                         | Minimum Photocell Input    | Default               |
|                         | Minimum Display Brightness | Default               |
|                         | Maximum Photocell Input    | Default               |
|                         | Maximum Display Brightness | Default               |
|                         | Filter Time Constant       | Default               |
| Display                 | HSI Page                   | Enabled               |
|                         | Power Up Page              | HSI                   |
| Battery                 | Show Battery Status        | When Using Battery    |
|                         | Automatic Power Off        | On Ground Only        |
| GPS                     | Internal GPS Receiver      | Disabled              |
| RS-232                  | Input Format               | AVIATION              |
|                         | Output Format              | None                  |
| Exit Configuration Mode |                            |                       |



### 5.15.3 GNC 300XL / GPS 155XL Configuration

| Config Page             | Config Option   | Configuration Setting |
|-------------------------|-----------------|-----------------------|
| RS-232 Configuration    | CHANNEL1 IN     | Input = OFF           |
|                         | CHANNEL1 OUT    | Output = AVIATION     |
| ARINC 429 Configuration | ARINC 429 In 1  | Course/Heading        |
|                         | ARINC 429 Out 1 | KING EFS 40/50        |

Note 1: Set configuration values and units to match the values indicated in the appropriate AFM and document settings in the space provided.

Note 2: If the aircraft has no AFM set the values as determined by the existing placards, instrument bugs or instrument markings.

Note 3: Existing placards related to airspeed limitations must be retained.

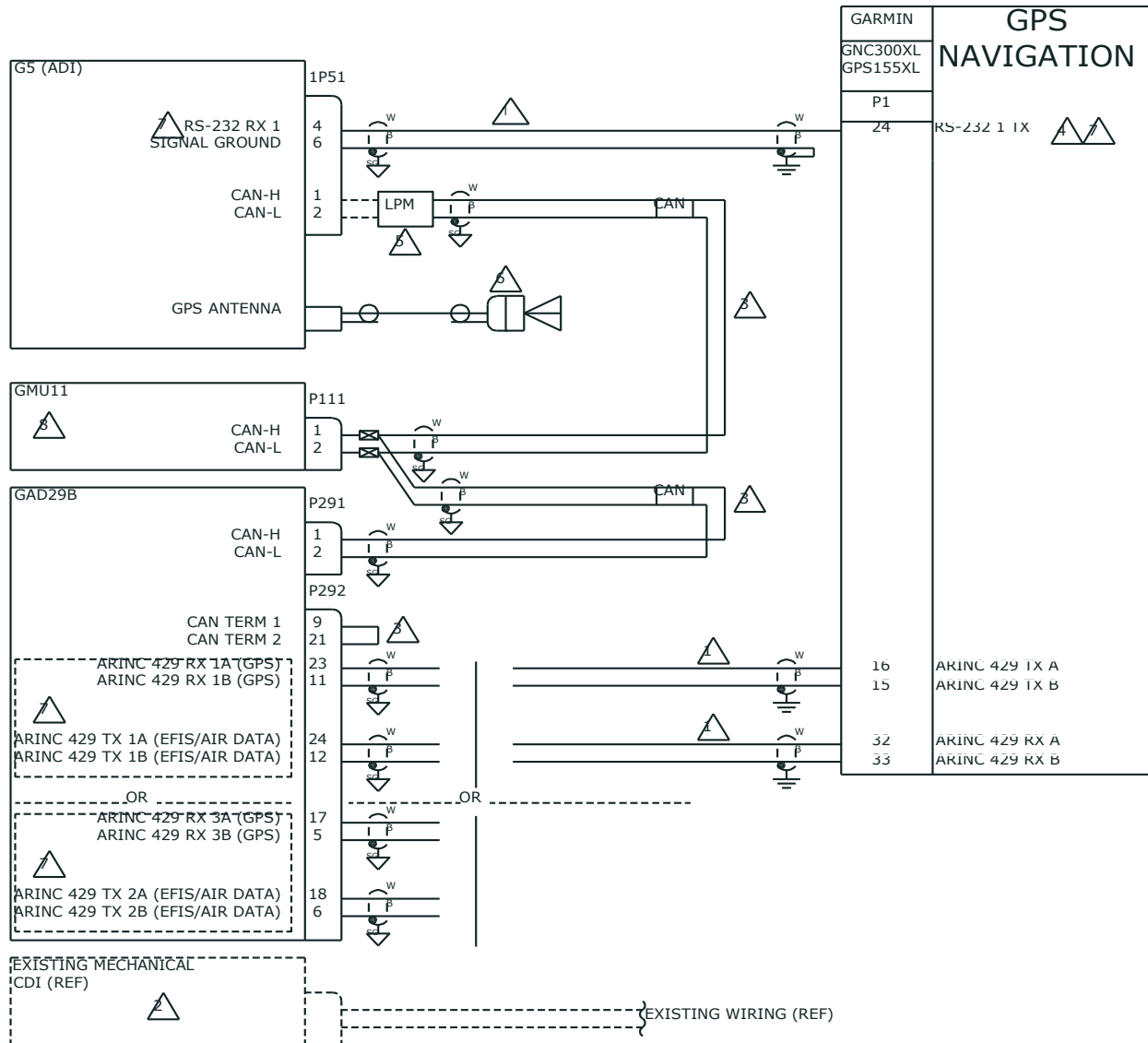
Note 4: Setting can remain at default setting, not supported in this configuration.

Note 5: The “Selected Course” will display when only one navigator is interfaced to the G5.

Note 6: “Selected Course 1” and “Selected Course 2” will display when dual navigators are interfaced.

*This area intentionally blank*

## 5.16 G5 (ADI) with GPS Navigator



- IT IS ACCEPTABLE TO SPLICE WIRES TO EXISTING WIRING OR EXISTING WIRING MAY BE RE-USED IF WIRE LENGTH IS SUFFICIENT TO REACH G5/GAD29B. SHIELD LEADS MUST BE MAX 3.0 INCHES. REFER TO UNIT INSTALLATION MANUALS FOR MORE INFORMATION.
- EXISTING MECHANICAL CDI IS TO BE RETAINED FOR SINGLE G5 ADI INSTALLATIONS TO ALLOW A COURSE SETTING INPUT TO EXISTING NAVIGATORS.
- CAN BUS LRUS MAY BE IN ANY ORDER ALONG BACKBONE AS LONG AS CAN BUS BACKBONE STRUCTURE GUIDELINES ARE FOLLOWED. REFER TO THE CAN BUS TERMINATION SECTION FOR FURTHER CAN BUS INFORMATION.
- CONNECT TO ANY APPROPRIATELY CONFIGURED, AVAILABLE RS-232 PORT.
- REFERENCE LIGHTNING PROTECTION MODULE (LPM) WIRING INTERFACE INTERCONNECT FOR DETAILED INSTALLATION REQUIREMENTS OF THE LPM.
- CONNECTION TO A GPS ANTENNA REQUIRED. THE GPS155XL/GNC300XL ARE NON WAAS UNITS. THE GLARE SHIELD MOUNTED GPS ANTENNA P/N 011-04036-00 REQUIRES A BNC/TNC ADAPTER P/N 330-01754-00 FOR CONNECTION TO THE G5.
- IF INTERFACED WITH DUAL NAVIGATORS, CONNECT THE G5 RS-232 AND ONE SET OF ARINC 429 CONNECTIONS TO THE #1 NAVIGATOR. CONNECT THE #2 NAVIGATOR VIA ONE SET OF THE ARINC 429 CONNECTIONS. SEE CONFIGURATION TABLE FOR APPLICABLE CONFIGURATION SETTINGS.
- GMU11 ONLY REQUIRED FOR A G5 INSTALLED IN THE DG POSITION. GMU11 IS OPTIONAL FOR A G5 INSTALLED IN THE ADI OR TURN COORDINATOR POSITION.

**Figure 5-19 G5 (ADI) with GPS Navigator**



## 5.16.1 ADI Configuration

| Config Page                                                                  | Config Option                | Configuration Setting                                                                                         |
|------------------------------------------------------------------------------|------------------------------|---------------------------------------------------------------------------------------------------------------|
| Device Information                                                           | Installation Type            | Certified Instrument                                                                                          |
|                                                                              | Diagnostics/Data Log         | Enabled                                                                                                       |
| Attitude Configuration                                                       | Indicator Type               | Normal                                                                                                        |
|                                                                              | Pitch Display                | Normal                                                                                                        |
|                                                                              | Roll Display                 | For Fixed Type Pointers G5 Config = Ground Pointer<br>or<br>For Movable Type Pointers G5 Config = Sky Pointer |
|                                                                              | Standard Turn Roll Reference | Hide                                                                                                          |
|                                                                              | Automatic Declutter          | Enabled                                                                                                       |
| Air Data                                                                     | Air Data Sensors             | Enabled                                                                                                       |
|                                                                              | Outside Air Temp Sensor      | Enabled<br><b>Note: if a GAD 13 is not installed, select Disabled</b>                                         |
|                                                                              | Vertical Speed Indicator     | (1)(2)                                                                                                        |
| Airspeed<br><br><b>Note: Configure Units prior to setting<br/>airspeeds.</b> | VNE                          | (1)(2)(3)                                                                                                     |
|                                                                              | VNO                          | (1)(2)(3)                                                                                                     |
|                                                                              | VSO                          | (1)(2)(3)                                                                                                     |
|                                                                              | VS1                          | (1)(2)(3)                                                                                                     |
|                                                                              | VFE                          | (1)(2)(3)                                                                                                     |
|                                                                              | VA                           | (1)(2)(3)                                                                                                     |
|                                                                              | VX                           | (1)(2)(3)                                                                                                     |
|                                                                              | VY                           | (1)(2)(3)                                                                                                     |
|                                                                              | VG                           | (1)(2)(3)                                                                                                     |
|                                                                              | VR                           | (1)(2)(3)                                                                                                     |
|                                                                              | VMC                          | (1)(2)(3)                                                                                                     |
| VYSE                                                                         | (1)(2)(3)                    |                                                                                                               |
| Magnetometer                                                                 | Magnetometer                 | Enabled (if GMU 11 is connected)<br>Disabled (if GMU 11 is not connected)                                     |
|                                                                              | Orientation                  | Connector Aft<br>Or<br>Connector Forward<br>Or<br>Connector Port<br>Or<br>Connector Starboard                 |
| Flight Controls                                                              | Garmin Autopilot Servos      | None                                                                                                          |
|                                                                              | Analog Autopilot Interface   | None<br>Or<br>See Section 5.24 if a Non-Garmin Autopilot is interfaced                                        |
| Backlight                                                                    | Current Mode                 | Automatic                                                                                                     |
|                                                                              | Default Mode                 | Automatic                                                                                                     |
|                                                                              | Minimum Photocell Input      | Default                                                                                                       |
|                                                                              | Minimum Display Brightness   | Default                                                                                                       |
|                                                                              | Maximum Photocell Input      | Default                                                                                                       |
|                                                                              | Maximum Display Brightness   | Default                                                                                                       |
|                                                                              | Filter Time Constant         | Default                                                                                                       |
| Display                                                                      | HSI Page                     | Disabled                                                                                                      |
|                                                                              | Power Up Page                | PFD                                                                                                           |
| Battery                                                                      | Show Battery Status          | When Using Battery                                                                                            |
|                                                                              | Automatic Power Off          | On Ground Only                                                                                                |
| GPS                                                                          | Internal GPS Receiver        | Enabled                                                                                                       |
|                                                                              | GPS Data Fields              | Show                                                                                                          |





| Config Page             | Config Option        | Configuration Setting                                                                                                  |
|-------------------------|----------------------|------------------------------------------------------------------------------------------------------------------------|
| Navigation              | Navigation Data      | Enabled<br><b>Note: If an autopilot interface is configured, this configuration page is set to ENABLED by default.</b> |
|                         | Selected Course      | Enabled (5)                                                                                                            |
|                         | Selected Course 1    | Enabled (6)                                                                                                            |
|                         | Selected Course 2    | Enabled (6)                                                                                                            |
|                         | VNAV Deviation Scale | (4)                                                                                                                    |
| Units                   | Altitude             | (1)(2)                                                                                                                 |
|                         | Distance             | (1)(2)                                                                                                                 |
|                         | Airspeed             | (1)(2)(3)                                                                                                              |
|                         | Ground Speed         | (1)(2)                                                                                                                 |
|                         | Navigation Angle     | Magnetic                                                                                                               |
|                         | Vertical Speed       | (1)(2)                                                                                                                 |
|                         | Pressure             | (1)(2)                                                                                                                 |
| RS-232                  | Input Format         | AVIATION                                                                                                               |
|                         | Output Format        | None                                                                                                                   |
| ARINC 429               | Output 1             | EFIS / AIRDATA 1 (SDI 1)<br>(If GPS/GNC is installed as #1 navigator)                                                  |
|                         | Output 2             | EFIS / AIRDATA 1 (SDI 2)<br>(If GPS/GNC is installed as #2 navigator)                                                  |
|                         | Input 1              | Garmin GPS (Common)<br>(If GPS/GNC is installed as #1 navigator)                                                       |
|                         | Input 2              | None                                                                                                                   |
|                         | Input 3              | Garmin GPS (Common)<br>(If GPS/GNC is installed as #2 navigator)                                                       |
|                         | Input 4              | None                                                                                                                   |
| Exit Configuration Mode |                      |                                                                                                                        |

### 5.16.2 GNC300XL/GPS155XL Configuration

| Config Page             | Config Option   | Configuration Setting |
|-------------------------|-----------------|-----------------------|
| RS-232 Configuration    | CHANNEL1 IN     | Input = OFF           |
|                         | CHANNEL1 OUT    | Output = AVIATION     |
| ARINC 429 Configuration | ARINC 429 In 1  | Course/Heading        |
|                         | ARINC 429 Out 1 | KING EFS 40/50        |

Note 1: Set configuration values and units to match the values indicated in the appropriate AFM and document settings in the space provided.

Note 2: If the aircraft has no AFM set the values as determined by the existing placards, instrument bugs or instrument markings.

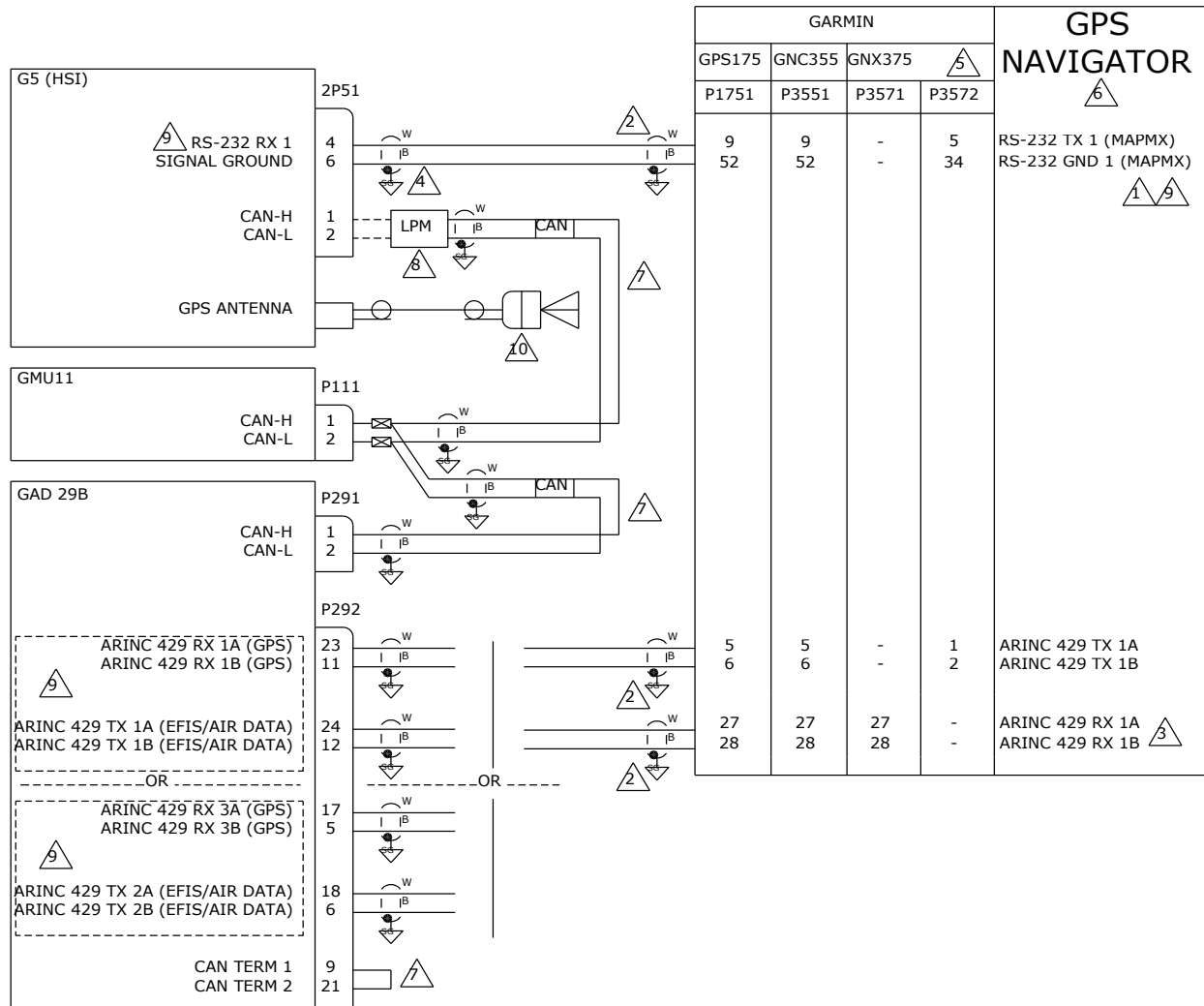
Note 3: Existing placards related to airspeed limitations must be retained.

Note 4: Setting can remain at default setting, not supported in this configuration.

Note 5: The “Selected Course” will display when only one navigator is interfaced to the G5.

Note 6: “Selected Course 1” and “Selected Course 2” will display when dual navigators are interfaced.

## 5.17 G5 (HSI) with Two-Inch GPS Navigator



- 1 CONNECT TO AN APPROPRIATELY CONFIGURED, AVAILABLE RS-232 PORT. FOR THE GNX375, THIS MUST BE PORT 1 OR PORT 2. SEE CONFIGURATION TABLE BELOW FOR CONFIGURATION SETTINGS.
- 2 IT IS ACCEPTABLE TO SPLICE WIRES TO EXISTING WIRING OR EXISTING WIRING MAY BE RE-USED IF WIRE LENGTH IS SUFFICIENT TO REACH G5/GAD29B. TERMINATE SHIELD GROUNDS TO CONNECTOR BACKSHELL. SHIELD LEADS MUST BE MAX 3.0 INCHES. REFER TO UNIT INSTALLATION MANUALS FOR MORE INFORMATION.
- 3 CONNECT TO ANY APPROPRIATELY CONFIGURED, AVAILABLE ARINC 429 RX PORT.
- 4 IT IS ACCEPTABLE TO SPLICE THE MAPMX RS-232 TX WIRE AND GROUND WIRE WITH ANOTHER LRU THAT REQUIRES THESE CONNECTIONS.
- 5 MAPMX RS-232 SHALL BE CONNECTED TO RS-232 PORT 1 OR 2 ON THE GNX375.
- 6 THIS STC DOES NOT APPROVE A CDI INTERFACED WITH THE SAME NAVIGATOR AS THE G5. REMOVE ANY EXISTING CDI INTERFACED WITH THIS NAVIGATOR.
- 7 CAN BUS LRUS MAY BE IN ANY ORDER ALONG BACKBONE AS LONG AS CAN BUS BACKBONE STRUCTURE GUIDELINES ARE FOLLOWED. REFER TO THE CAN BUS TERMINATION SECTION FOR FURTHER CAN BUS INFORMATION.
- 8 REFERENCE LIGHTNING PROTECTION MODULE (LPM) WIRING INTERFACE INTERCONNECT FOR DETAILED INSTALLATION REQUIREMENTS OF THE LPM.
- 9 IF INTERFACED WITH DUAL NAVIGATORS, CONNECT THE G5 RS-232 TO THE #1 NAVIGATOR. CONNECT THE #2 NAVIGATOR VIA ARINC 429 CONNECTIONS, IF AVAILABLE. THE #2 NAVIGATOR SHALL NOT BE CONNECTED TO THE G5 VIA RS-232. SEE CONFIGURATION TABLE FOR APPLICABLE CONFIGURATION SETTINGS.
- 10 THE GLARE SHIELD MOUNTED GPS ANTENNA P/N 011-04036-00 REQUIRES A BNC/TNC ADAPTER P/N 330-01754-00 FOR CONNECTION TO THE G5.

**Figure 5-20 G5 (HSI) with GPS Navigator**



## 5.17.1 HSI Configuration

| Config Page                                                       | Config Option                | Configuration Setting                                                                                         |
|-------------------------------------------------------------------|------------------------------|---------------------------------------------------------------------------------------------------------------|
| Device Information                                                | Installation Type            | Certified Instrument                                                                                          |
|                                                                   | Diagnostics/Data Log         | Enabled                                                                                                       |
| Attitude Configuration                                            | Indicator Type               | Normal                                                                                                        |
|                                                                   | Pitch Display                | Normal                                                                                                        |
|                                                                   | Roll Display                 | For Fixed Type Pointers G5 Config = Ground Pointer<br>or<br>For Movable Type Pointers G5 Config = Sky Pointer |
|                                                                   | Standard Turn Roll Reference | Hide                                                                                                          |
|                                                                   | Automatic Declutter          | Disabled                                                                                                      |
| Air Data                                                          | Air Data Sensors             | Enabled                                                                                                       |
|                                                                   | Outside Air Temp Sensor      | Enabled<br><b>Note: if a GAD 13 is not installed, select Disabled</b>                                         |
|                                                                   | Vertical Speed Indicator     | (1)(2)                                                                                                        |
| Airspeed<br><br>Note: Configure Units prior to setting airspeeds. | VNE                          | (1)(2)(3)                                                                                                     |
|                                                                   | VNO                          | (1)(2)(3)                                                                                                     |
|                                                                   | VSO                          | (1)(2)(3)                                                                                                     |
|                                                                   | VS1                          | (1)(2)(3)                                                                                                     |
|                                                                   | VFE                          | (1)(2)(3)                                                                                                     |
|                                                                   | VA                           | (1)(2)(3)                                                                                                     |
|                                                                   | VX                           | (1)(2)(3)                                                                                                     |
|                                                                   | VY                           | (1)(2)(3)                                                                                                     |
|                                                                   | VG                           | (1)(2)(3)                                                                                                     |
|                                                                   | VR                           | (1)(2)(3)                                                                                                     |
|                                                                   | VMC                          | (1)(2)(3)                                                                                                     |
| VYSE                                                              | (1)(2)(3)                    |                                                                                                               |
| Magnetometer                                                      | Magnetometer                 | Enabled                                                                                                       |
|                                                                   | Orientation                  | Connector Aft<br>Or<br>Connector Forward<br>Or<br>Connector Port<br>Or<br>Connector Starboard                 |
| Flight Controls                                                   | Garmin Autopilot Servos      | None                                                                                                          |
|                                                                   | Analog Autopilot Interface   | None<br>Or<br>See Section 5.24 if a Non-Garmin Autopilot is interfaced                                        |
| Backlight                                                         | Current Mode                 | Automatic                                                                                                     |
|                                                                   | Default Mode                 | Automatic                                                                                                     |
|                                                                   | Minimum Photocell Input      | Default                                                                                                       |
|                                                                   | Minimum Display Brightness   | Default                                                                                                       |
|                                                                   | Maximum Photocell Input      | Default                                                                                                       |
|                                                                   | Maximum Display Brightness   | Default                                                                                                       |
| Filter Time Constant                                              | Default                      |                                                                                                               |
| Display                                                           | HSI Page                     | Enabled                                                                                                       |
|                                                                   | Power Up Page                | HSI                                                                                                           |
| Battery                                                           | Show Battery Status          | When Using Battery                                                                                            |
|                                                                   | Automatic Power Off          | On Ground Only                                                                                                |
| GPS                                                               | Internal GPS Receiver        | Disabled (if G5 is not connected to GPS antenna)<br>Enabled (if G5 is connected to GPS antenna)               |
|                                                                   | GPS Data Fields              | Show                                                                                                          |



| Config Page             | Config Option        | Configuration Setting                                                                                                  |
|-------------------------|----------------------|------------------------------------------------------------------------------------------------------------------------|
| Navigation              | Navigation Data      | Enabled<br><b>Note: If an autopilot interface is configured, this configuration page is set to ENABLED by default.</b> |
|                         | Selected Course      | Enabled (5)                                                                                                            |
|                         | Selected Course 1    | Enabled (6)                                                                                                            |
|                         | Selected Course 2    | Enabled (6)                                                                                                            |
|                         | VNAV Deviation Scale | (4)                                                                                                                    |
| Units                   | Altitude             | (1)(2)                                                                                                                 |
|                         | Distance             | (1)(2)                                                                                                                 |
|                         | Airspeed             | (1)(2)(3)                                                                                                              |
|                         | Ground Speed         | (1)(2)                                                                                                                 |
|                         | Navigation Angle     | Magnetic                                                                                                               |
|                         | Vertical Speed       | (1)(2)                                                                                                                 |
|                         | Pressure             | (1)(2)                                                                                                                 |
| RS-232                  | Input Format         | MapMx                                                                                                                  |
|                         | Output Format        | None                                                                                                                   |
| ARINC 429               | Output 1             | EFIS / AIRDATA 1 (SDI 1)<br>(Only used with <b>no</b> autopilot or Garmin autopilot interfaced )                       |
|                         |                      | EFIS / AIRDATA 2 (SDI 1)<br>(Always used when Non-Garmin Autopilot is interfaced )                                     |
|                         | Output 2             | EFIS / AIRDATA 1 (SDI 2)<br>(Only used with <b>no</b> autopilot or Garmin autopilot interfaced )                       |
|                         |                      | EFIS / AIRDATA 2 (SDI 2)<br>(Always used when Non-Garmin Autopilot is interfaced )                                     |
|                         | Input 1              | Garmin GPS (SDI 1)<br>(If GPS/GNX is #1 navigator)                                                                     |
|                         | Input 2              | None                                                                                                                   |
|                         | Input 3              | Garmin GPS (SDI 2)<br>(If GPS/GNX is #2 navigator)                                                                     |
|                         | Input 4              | None                                                                                                                   |
| Exit Configuration Mode |                      |                                                                                                                        |

### 5.17.2 GPS 175/GNC 355 Configuration

| Config Page                      | Config Option                                                    | Configuration Setting                                                          |
|----------------------------------|------------------------------------------------------------------|--------------------------------------------------------------------------------|
| Interfaced Equipment - ARINC 429 | ARINC RX Port (x)<br>(x represents any available ARINC 429 Port) | Speed = Low<br>Format = GDU Format 1                                           |
|                                  | ARINC TX Port 1                                                  | Speed = Low<br>Format = GAMA Format 1                                          |
|                                  | SDI                                                              | LNAV1 (If GPS/GNC is #1 navigator)<br>Or<br>LNAV2 (If GPS/GNC is #2 navigator) |
| Interfaced Equipment – RS 232    | Port (x)<br>(x represents any available RS-232 Port)             | MapMX (Format 1)                                                               |
| Main System                      | Composite CDI                                                    | Disabled                                                                       |
| Main Indicator (Analog)          | Selected Course                                                  | Allowed                                                                        |

### 5.17.3 GNX 375 Configuration

| Config Page            | Config Option                                                    | Configuration Setting                 |
|------------------------|------------------------------------------------------------------|---------------------------------------|
| Interfaces - ARINC 429 | ARINC RX Port (x)<br>(x represents any available ARINC 429 Port) | Speed = Low<br>Format = EFIS/Air Data |
|                        | ARINC TX Port 1                                                  | Speed = Low<br>Format = GAMA Format 1 |



| Config Page                    | Config Option                                 | Configuration Setting                                                  |
|--------------------------------|-----------------------------------------------|------------------------------------------------------------------------|
|                                | SDI                                           | LNAV1 (If GNX is #1 navigator)<br>Or<br>LNAV2 (If GNX is #2 navigator) |
| <b>Interfaces – RS-232</b>     | Port (x)<br>(x represents RS-232 Port 1 or 2) | MapMX (Format 1)                                                       |
| <b>Main System</b>             | Composite CDI                                 | Disabled                                                               |
| <b>Main Indicator (Analog)</b> | Selected Course                               | Allowed                                                                |

Note 1: Set configuration values and units to match the values indicated in the appropriate AFM and document settings in the space provided.

Note 2: If the aircraft has no AFM set the values as determined by the existing placards, instrument bugs or instrument markings.

Note 3: Existing placards related to airspeed limitations must be retained.

Note 4: Setting can remain at default setting, not supported in this configuration.

Note 5: The “Selected Course” will display when only one navigator is interfaced to the G5.

Note 6: “Selected Course 1” and “Selected Course 2” will display when dual navigators are interfaced.

*This area intentionally blank*

## 5.18 Dual G5 with Two-Inch GPS Navigator

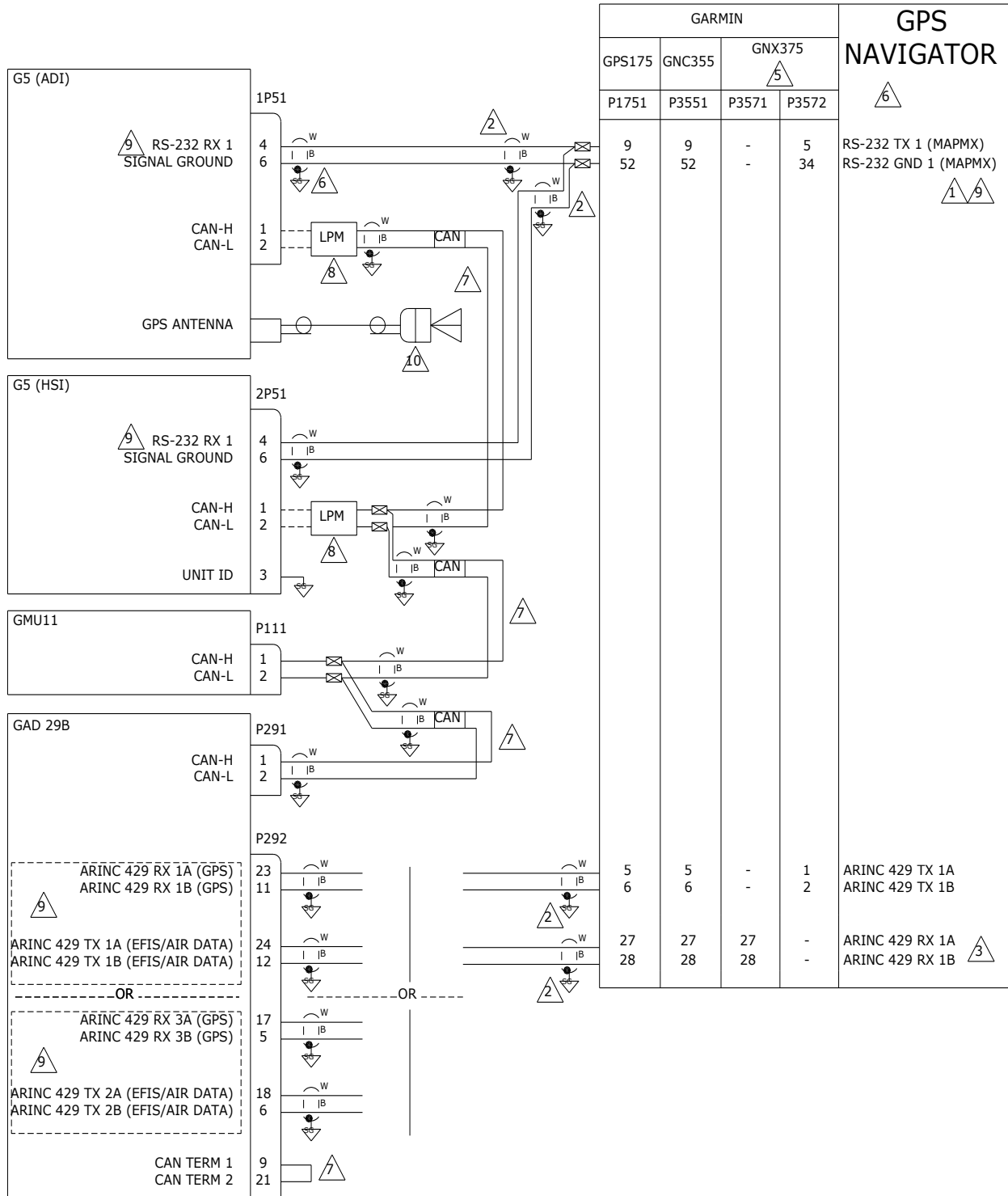


Figure 5-21 Dual G5 with Two-Inch GPS Navigator



- 1 CONNECT TO AN APPROPRIATELY CONFIGURED, AVAILABLE RS-232 PORT. SEE CONFIGURATION TABLE BELOW FOR CONFIGURATION SETTINGS.
- 2 IT IS ACCEPTABLE TO SPLICE WIRES TO EXISTING WIRING OR EXISTING WIRING MAY BE RE-USED IF WIRE LENGTH IS SUFFICIENT TO REACH G5/GAD29B. TERMINATE SHIELD GROUNDS TO CONNECTOR BACKSHELL. SHIELD LEADS MUST BE MAX 3.0 INCHES. REFER TO UNIT INSTALLATION MANUALS FOR MORE INFORMATION.
- 3 CONNECT TO ANY APPROPRIATELY CONFIGURED, AVAILABLE ARINC 429 RX PORT.
- 4 IT IS ACCEPTABLE TO SPLICE THE MAPMX RS-232 TX WIRE AND GROUND WIRE WITH ANOTHER LRU THAT REQUIRES THESE CONNECTIONS.
- 5 MAPMX RS-232 SHALL BE CONNECTED TO RS-232 PORT 1 OR 2 ON THE GNX375.
- 6 THIS STC DOES NOT APPROVE A CDI INTERFACED WITH THE SAME NAVIGATOR AS THE G5. REMOVE ANY EXISTING CDI INTERFACED WITH THIS NAVIGATOR.
- 7 CAN BUS LRUS MAY BE IN ANY ORDER ALONG BACKBONE AS LONG AS CAN BUS BACKBONE STRUCTURE GUIDELINES ARE FOLLOWED. REFER TO THE CAN BUS TERMINATION SECTION FOR FURTHER CAN BUS INFORMATION.
- 8 REFERENCE LIGHTNING PROTECTION MODULE (LPM) WIRING INTERFACE INTERCONNECT FOR DETAILED INSTALLATION REQUIREMENTS OF THE LPM.
- 9 IF INTERFACED WITH DUAL NAVIGATORS, CONNECT THE G5 RS-232 TO THE #1 NAVIGATOR. CONNECT THE #2 NAVIGATOR VIA ARINC 429 CONNECTIONS, IF AVAILABLE. THE #2 NAVIGATOR SHALL NOT BE CONNECTED TO THE G5 VIA RS-232. SEE CONFIGURATION TABLE FOR APPLICABLE CONFIGURATION SETTINGS.
- 10 THE GLARE SHIELD MOUNTED GPS ANTENNA P/N 011-04036-00 REQUIRES A BNC/TNC ADAPTER P/N 330-01754-00 FOR CONNECTION TO THE G5.

**Figure 5-22 Dual G5 with Two-Inch GPS Navigator Notes**

### 5.18.1 ADI Configuration

| Config Page                                                                  | Config Option                | Configuration Setting                                                                                         |
|------------------------------------------------------------------------------|------------------------------|---------------------------------------------------------------------------------------------------------------|
| Device Information                                                           | Installation Type            | Certified Instrument                                                                                          |
|                                                                              | Diagnostics/Data Log         | Enabled                                                                                                       |
| Attitude Configuration                                                       | Indicator Type               | Normal                                                                                                        |
|                                                                              | Pitch Display                | Normal                                                                                                        |
|                                                                              | Roll Display                 | For Fixed Type Pointers G5 Config = Ground Pointer<br>or<br>For Movable Type Pointers G5 Config = Sky Pointer |
|                                                                              | Standard Turn Roll Reference | Hide                                                                                                          |
|                                                                              | Automatic Declutter          | Enabled                                                                                                       |
| Air Data                                                                     | Air Data Sensors             | Enabled                                                                                                       |
|                                                                              | Outside Air Temp Sensor      | Enabled                                                                                                       |
|                                                                              | Vertical Speed Indicator     | <b>Note: if a GAD 13 is not installed, select Disabled</b><br>(1)(2)                                          |
| Airspeed<br><br><b>Note: Configure Units prior to setting<br/>airspeeds.</b> | VNE                          | (1)(2)(3)                                                                                                     |
|                                                                              | VNO                          | (1)(2)(3)                                                                                                     |
|                                                                              | VSO                          | (1)(2)(3)                                                                                                     |
|                                                                              | VS1                          | (1)(2)(3)                                                                                                     |
|                                                                              | VFE                          | (1)(2)(3)                                                                                                     |
|                                                                              | VA                           | (1)(2)(3)                                                                                                     |
|                                                                              | VX                           | (1)(2)(3)                                                                                                     |
|                                                                              | VY                           | (1)(2)(3)                                                                                                     |
|                                                                              | VG                           | (1)(2)(3)                                                                                                     |
|                                                                              | VR                           | (1)(2)(3)                                                                                                     |
|                                                                              | VMC                          | (1)(2)(3)                                                                                                     |
| VYSE                                                                         | (1)(2)(3)                    |                                                                                                               |



| Config Page     | Config Option              | Configuration Setting                                                                                                  |
|-----------------|----------------------------|------------------------------------------------------------------------------------------------------------------------|
| Magnetometer    | Magnetometer               | Enabled                                                                                                                |
|                 | Orientation                | Connector Aft<br>Or<br>Connector Forward<br>Or<br>Connector Port<br>Or<br>Connector Starboard                          |
| Flight Controls | Garmin Autopilot Servos    | None                                                                                                                   |
|                 | Analog Autopilot Interface | None<br>Or<br>See Section 5.24 if a Non-Garmin Autopilot is interfaced                                                 |
| Backlight       | Current Mode               | Automatic                                                                                                              |
|                 | Default Mode               | Automatic                                                                                                              |
|                 | Minimum Photocell Input    | Default                                                                                                                |
|                 | Minimum Display Brightness | Default                                                                                                                |
|                 | Maximum Photocell Input    | Default                                                                                                                |
|                 | Maximum Display Brightness | Default                                                                                                                |
|                 | Filter Time Constant       | Default                                                                                                                |
| Display         | HSI Page                   | Disabled                                                                                                               |
|                 | Power Up Page              | PFD                                                                                                                    |
| Battery         | Show Battery Status        | When Using Battery                                                                                                     |
|                 | Automatic Power Off        | On Ground Only                                                                                                         |
| GPS             | Internal GPS Receiver      | Disabled (if G5 is not connected to GPS antenna)<br>Enabled (if G5 is connected to GPS antenna)                        |
|                 | GPS Data Fields            | Show                                                                                                                   |
| Navigation      | Navigation Data            | Enabled<br><b>Note: If an autopilot interface is configured, this configuration page is set to ENABLED by default.</b> |
|                 | Selected Course            | Enabled (5)                                                                                                            |
|                 | Selected Course 1          | Enabled (6)                                                                                                            |
|                 | Selected Course 2          | Enabled (6)                                                                                                            |
|                 | VNAV Deviation Scale       | (4)                                                                                                                    |
| Units           | Altitude                   | (1)(2)                                                                                                                 |
|                 | Distance                   | (1)(2)                                                                                                                 |
|                 | Airspeed                   | (1)(2)(3)                                                                                                              |
|                 | Ground Speed               | (1)(2)                                                                                                                 |
|                 | Navigation Angle           | Magnetic                                                                                                               |
|                 | Vertical Speed             | (1)(2)                                                                                                                 |
|                 | Pressure                   | (1)(2)                                                                                                                 |
| RS-232          | Input Format               | MapMx                                                                                                                  |
|                 | Output Format              | None                                                                                                                   |
| ARINC 429       | Output 1                   | EFIS / AIRDATA 1 (SDI 1)<br>(Only used with <b>no</b> autopilot or Garmin autopilot interfaced )                       |
|                 |                            | EFIS / AIRDATA 2 (SDI 1)<br>(Always used when Non-Garmin Autopilot is interfaced )                                     |
|                 | Output 2                   | EFIS / AIRDATA 1 (SDI 2)<br>(Only used with <b>no</b> autopilot or Garmin autopilot interfaced )                       |
|                 |                            | EFIS / AIRDATA 2 (SDI 2)<br>(Always used when Non-Garmin Autopilot is interfaced )                                     |
|                 | Input 1                    | Garmin GPS (SDI 1)<br>(If GPS/GNX is #1 navigator)                                                                     |
| Input 2         | None                       |                                                                                                                        |





| Config Page                    | Config Option | Configuration Setting                |
|--------------------------------|---------------|--------------------------------------|
|                                | Input 3       | Garmin GPS (SDI 2)                   |
|                                | Input 4       | (If GPS/GNX is #2 navigator)<br>None |
| <b>Exit Configuration Mode</b> |               |                                      |

### 5.18.2 HSI Configuration

| Config Page                    | Config Option              | Configuration Setting |
|--------------------------------|----------------------------|-----------------------|
| <b>Device Information</b>      | Installation Type          | Certified Instrument  |
|                                | Diagnostics/Data Log       | Enabled               |
| <b>Attitude Configuration</b>  | Automatic Declutter        | Disabled              |
| <b>Backlight</b>               | Current Mode               | Automatic             |
|                                | Default Mode               | Automatic             |
|                                | Minimum Photocell Input    | Default               |
|                                | Minimum Display Brightness | Default               |
|                                | Maximum Photocell Input    | Default               |
|                                | Maximum Display Brightness | Default               |
|                                | Filter Time Constant       | Default               |
| <b>Display</b>                 | HSI Page                   | Enabled               |
|                                | Power Up Page              | HSI                   |
| <b>Battery</b>                 | Show Battery Status        | When Using Battery    |
|                                | Automatic Power Off        | On Ground Only        |
| <b>GPS</b>                     | Internal GPS Receiver      | Disabled              |
| <b>RS-232</b>                  | Input Format               | MapMx                 |
|                                | Output Format              | None                  |
| <b>Exit Configuration Mode</b> |                            |                       |

### 5.18.3 GPS 175/GNC 355 Configuration

| Config Page                             | Config Option                                                    | Configuration Setting                                                          |
|-----------------------------------------|------------------------------------------------------------------|--------------------------------------------------------------------------------|
| <b>Interfaced Equipment - ARINC 429</b> | ARINC RX Port (x)<br>(x represents any available ARINC 429 Port) | Speed = Low<br>Format = GDU Format 1                                           |
|                                         | ARINC TX Port 1                                                  | Speed = Low<br>Format = GAMA Format 1                                          |
|                                         | SDI                                                              | LNAV1 (If GPS/GNC is #1 navigator)<br>Or<br>LNAV2 (If GPS/GNC is #2 navigator) |
| <b>Interfaced Equipment – RS 232</b>    | Port (x)<br>(x represents any available RS-232 Port)             | MapMX (Format 1)                                                               |
| <b>Main System</b>                      | Composite CDI                                                    | Disabled                                                                       |
| <b>Main Indicator (Analog)</b>          | Selected Course                                                  | Allowed                                                                        |

### 5.18.4 GNX 375 Configuration

| Config Page                   | Config Option                                                    | Configuration Setting                 |
|-------------------------------|------------------------------------------------------------------|---------------------------------------|
| <b>Interfaces - ARINC 429</b> | ARINC RX Port (x)<br>(x represents any available ARINC 429 Port) | Speed = Low<br>Format = EFIS/Air Data |
|                               | ARINC TX Port 1                                                  | Speed = Low<br>Format = GAMA Format 1 |



| Config Page                    | Config Option                                 | Configuration Setting                                                  |
|--------------------------------|-----------------------------------------------|------------------------------------------------------------------------|
|                                | SDI                                           | LNAV1 (If GNX is #1 navigator)<br>Or<br>LNAV2 (If GNX is #2 navigator) |
| <b>Interfaces – RS-232</b>     | Port (x)<br>(x represents RS-232 Port 1 or 2) | MapMX (Format 1)                                                       |
| <b>Main System</b>             | Composite CDI                                 | Disabled                                                               |
| <b>Main Indicator (Analog)</b> | Selected Course                               | Allowed                                                                |

Note 1: Set configuration values and units to match the values indicated in the appropriate AFM and document settings in the space provided.

Note 2: If the aircraft has no AFM set the values as determined by the existing placards, instrument bugs or instrument markings.

Note 3: Existing placards related to airspeed limitations must be retained.

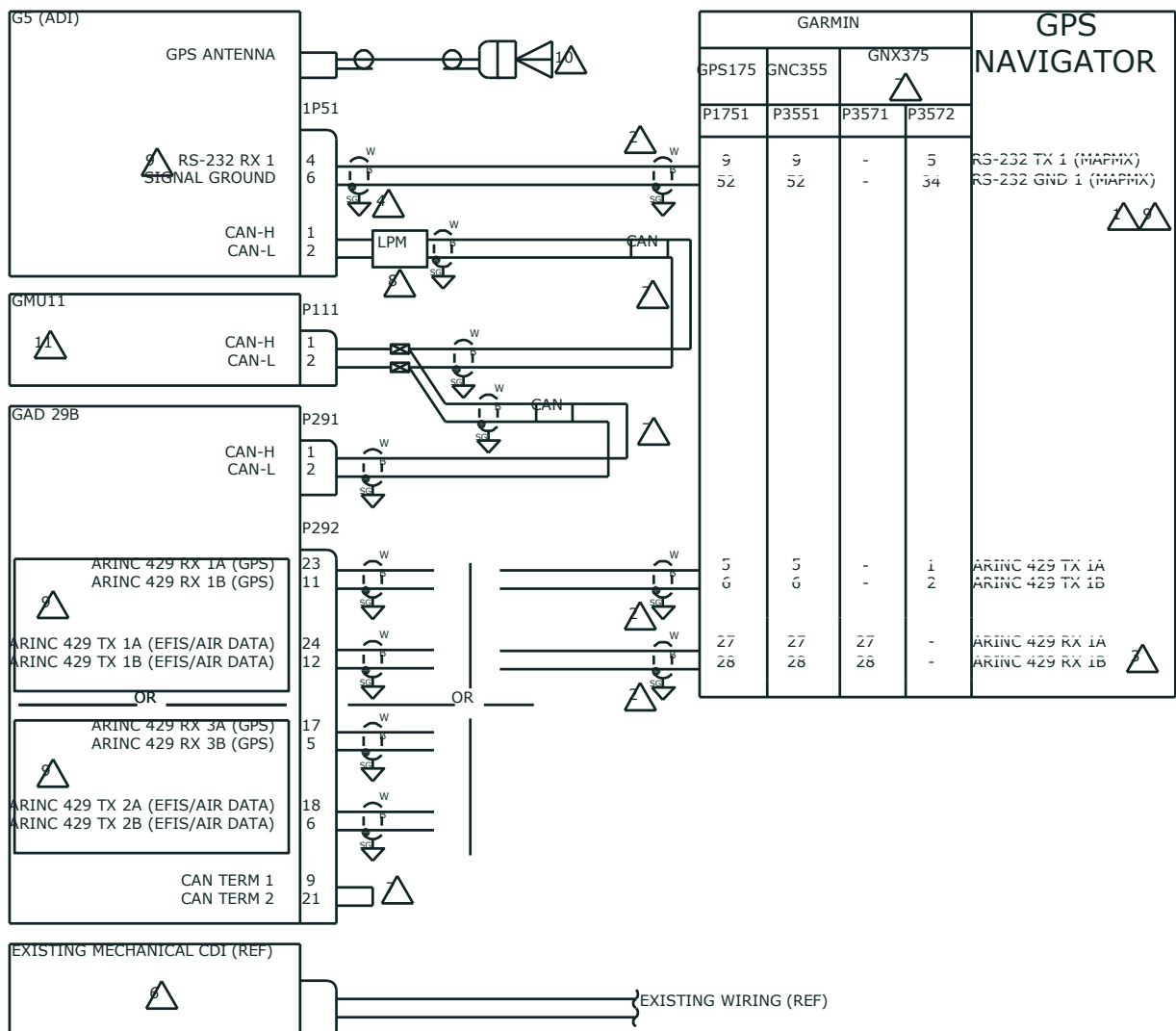
Note 4: Setting can remain at default setting, not supported in this configuration.

Note 5: The “Selected Course” will display when only one navigator is interfaced to the G5.

Note 6: “Selected Course 1” and “Selected Course 2” will display when dual navigators are interfaced.

*This area intentionally blank*

## 5.19 G5 (ADI) with Two-Inch GPS Navigator



- CONNECT TO AN APPROPRIATELY CONFIGURED, AVAILABLE RS-232 PORT. SEE CONFIGURATION TABLE BELOW FOR CONFIGURATION SETTINGS.
- IT IS ACCEPTABLE TO SPLICE WIRES TO EXISTING WIRING OR EXISTING WIRING MAY BE RE-USED IF WIRE LENGTH IS SUFFICIENT TO REACH G5/GAD29B. TERMINATE SHIELD GROUNDS TO CONNECTOR BACKSHELL. SHIELD LEADS MUST BE MAX 3.0 INCHES. REFER TO UNIT INSTALLATION MANUALS FOR MORE INFORMATION.
- CONNECT TO ANY APPROPRIATELY CONFIGURED, AVAILABLE ARINC 429 RX PORT.
- IT IS ACCEPTABLE TO SPLICE THE MAPMX RS-232 TX WIRE AND GROUND WIRE WITH ANOTHER LRU THAT REQUIRES THESE CONNECTIONS.
- MAPMX RS-232 SHALL BE CONNECTED TO RS-232 PORT 1 OR 2 ON THE GNX375.
- EXISTING MECHANICAL CDI IS TO BE RETAINED FOR SINGLE G5 ADI INSTALLATIONS TO ALLOW A COURSE SETTING INPUT TO EXISTING NAVIGATORS.
- CAN BUS LRUS MAY BE IN ANY ORDER ALONG BACKBONE AS LONG AS CAN BUS BACKBONE STRUCTURE GUIDELINES ARE FOLLOWED. REFER TO THE CAN BUS TERMINATION SECTION FOR FURTHER CAN BUS INFORMATION.
- REFERENCE LIGHTNING PROTECTION MODULE (LPM) WIRING INTERFACE INTERCONNECT FOR DETAILED INSTALLATION REQUIREMENTS OF THE LPM.
- IF INTERFACED WITH DUAL NAVIGATORS, CONNECT THE G5 RS-232 TO THE #1 NAVIGATOR. CONNECT THE #2 NAVIGATOR VIA ARINC 429 CONNECTIONS, IF AVAILABLE. THE #2 NAVIGATOR SHALL NOT BE CONNECTED TO THE G5 VIA RS-232. SEE CONFIGURATION TABLE FOR APPLICABLE CONFIGURATION SETTINGS.
- THE GLARE SHIELD MOUNTED GPS ANTENNA P/N 011-04036-00 REQUIRES A BNC/TNC ADAPTER P/N 330-01754-00 FOR CONNECTION TO THE G5.
- GMU11 ONLY REQUIRED FOR A G5 INSTALLED IN THE DG POSITION. GMU11 IS OPTIONAL FOR A G5 INSTALLED IN THE ADI OR TURN COORDINATOR POSITION.

**Figure 5-23 G5 (ADI) with Two-Inch GPS Navigator**



## 5.19.1 ADI Configuration

| Config Page                                                                  | Config Option                | Configuration Setting                                                                                         |
|------------------------------------------------------------------------------|------------------------------|---------------------------------------------------------------------------------------------------------------|
| Device Information                                                           | Installation Type            | Certified Instrument                                                                                          |
|                                                                              | Diagnostics/Data Log         | Enabled                                                                                                       |
| Attitude Configuration                                                       | Indicator Type               | Normal                                                                                                        |
|                                                                              | Pitch Display                | Normal                                                                                                        |
|                                                                              | Roll Display                 | For Fixed Type Pointers G5 Config = Ground Pointer<br>or<br>For Movable Type Pointers G5 Config = Sky Pointer |
|                                                                              | Standard Turn Roll Reference | Hide                                                                                                          |
|                                                                              | Automatic Declutter          | Enabled                                                                                                       |
| Air Data                                                                     | Air Data Sensors             | Enabled                                                                                                       |
|                                                                              | Outside Air Temp Sensor      | Enabled<br><b>Note: if a GAD 13 is not installed, select Disabled</b>                                         |
|                                                                              | Vertical Speed Indicator     | (1)(2)                                                                                                        |
| Airspeed<br><br><b>Note: Configure Units prior to setting<br/>airspeeds.</b> | VNE                          | (1)(2)(3)                                                                                                     |
|                                                                              | VNO                          | (1)(2)(3)                                                                                                     |
|                                                                              | VSO                          | (1)(2)(3)                                                                                                     |
|                                                                              | VS1                          | (1)(2)(3)                                                                                                     |
|                                                                              | VFE                          | (1)(2)(3)                                                                                                     |
|                                                                              | VA                           | (1)(2)(3)                                                                                                     |
|                                                                              | VX                           | (1)(2)(3)                                                                                                     |
|                                                                              | VY                           | (1)(2)(3)                                                                                                     |
|                                                                              | VG                           | (1)(2)(3)                                                                                                     |
|                                                                              | VR                           | (1)(2)(3)                                                                                                     |
|                                                                              | VMC                          | (1)(2)(3)                                                                                                     |
| VYSE                                                                         | (1)(2)(3)                    |                                                                                                               |
| Magnetometer                                                                 | Magnetometer                 | Enabled (if GMU 11 is connected)<br>Disabled (if GMU 11 is not connected)                                     |
|                                                                              | Orientation                  | Connector Aft<br>Or<br>Connector Forward<br>Or<br>Connector Port<br>Or<br>Connector Starboard                 |
| Flight Controls                                                              | Garmin Autopilot Servos      | None                                                                                                          |
|                                                                              | Analog Autopilot Interface   | None<br>Or<br>See Section 5.24 if a Non-Garmin Autopilot is interfaced                                        |
| Backlight                                                                    | Current Mode                 | Automatic                                                                                                     |
|                                                                              | Default Mode                 | Automatic                                                                                                     |
|                                                                              | Minimum Photocell Input      | Default                                                                                                       |
|                                                                              | Minimum Display Brightness   | Default                                                                                                       |
|                                                                              | Maximum Photocell Input      | Default                                                                                                       |
|                                                                              | Maximum Display Brightness   | Default                                                                                                       |
|                                                                              | Filter Time Constant         | Default                                                                                                       |
| Display                                                                      | HSI Page                     | Disabled                                                                                                      |
|                                                                              | Power Up Page                | PFD                                                                                                           |
| Battery                                                                      | Show Battery Status          | When Using Battery                                                                                            |
|                                                                              | Automatic Power Off          | On Ground Only                                                                                                |
| GPS                                                                          | Internal GPS Receiver        | Disabled (if G5 is not connected to GPS antenna)<br>Enabled (if G5 is connected to GPS antenna)               |
|                                                                              | GPS Data Fields              | Show                                                                                                          |



| Config Page             | Config Option        | Configuration Setting                                                                                                  |
|-------------------------|----------------------|------------------------------------------------------------------------------------------------------------------------|
| Navigation              | Navigation Data      | Enabled<br><b>Note: If an autopilot interface is configured, this configuration page is set to ENABLED by default.</b> |
|                         | Selected Course      | Enabled (5)                                                                                                            |
|                         | Selected Course 1    | Enabled (6)                                                                                                            |
|                         | Selected Course 2    | Enabled (6)                                                                                                            |
|                         | VNAV Deviation Scale | (4)                                                                                                                    |
| Units                   | Altitude             | (1)(2)                                                                                                                 |
|                         | Distance             | (1)(2)                                                                                                                 |
|                         | Airspeed             | (1)(2)(3)                                                                                                              |
|                         | Ground Speed         | (1)(2)                                                                                                                 |
|                         | Navigation Angle     | Magnetic                                                                                                               |
|                         | Vertical Speed       | (1)(2)                                                                                                                 |
|                         | Pressure             | (1)(2)                                                                                                                 |
| RS-232                  | Input Format         | MapMx                                                                                                                  |
|                         | Output Format        | None                                                                                                                   |
| ARINC 429               | Output 1             | EFIS / AIRDATA 1 (SDI 1)<br>(Only used with <b>no</b> autopilot or Garmin autopilot interfaced)                        |
|                         |                      | EFIS / AIRDATA 2 (SDI 1)<br>(Always used when Non-Garmin Autopilot is interfaced )                                     |
|                         | Output 2             | EFIS / AIRDATA 1 (SDI 2)<br>(Only used with <b>no</b> autopilot or Garmin autopilot interfaced)                        |
|                         |                      | EFIS / AIRDATA 2 (SDI 2)<br>(Always used when Non-Garmin Autopilot is interfaced )                                     |
|                         | Input 1              | Garmin GPS (SDI 1)<br>(If GPS/GNX is #1 navigator)                                                                     |
|                         | Input 2              | None                                                                                                                   |
|                         | Input 3              | Garmin GPS (SDI 2)<br>(If GPS/GNX is #2 navigator)                                                                     |
| Input 4                 | None                 |                                                                                                                        |
| Exit Configuration Mode |                      |                                                                                                                        |

### 5.19.2 GPS 175/GNC 355 Configuration

| Config Page                      | Config Option                                                    | Configuration Setting                                                          |
|----------------------------------|------------------------------------------------------------------|--------------------------------------------------------------------------------|
| Interfaced Equipment - ARINC 429 | ARINC RX Port (x)<br>(x represents any available ARINC 429 Port) | Speed = Low<br>Format = GDU Format 1                                           |
|                                  | ARINC TX Port 1                                                  | Speed = Low<br>Format = GAMA Format 1                                          |
|                                  | SDI                                                              | LNAV1 (If GPS/GNC is #1 navigator)<br>Or<br>LNAV2 (If GPS/GNC is #2 navigator) |
| Interfaced Equipment – RS 232    | Port (x)<br>(x represents any available RS-232 Port)             | MapMX (Format 1)                                                               |

### 5.19.3 GNX 375 Configuration

| Config Page            | Config Option                                                    | Configuration Setting                                                  |
|------------------------|------------------------------------------------------------------|------------------------------------------------------------------------|
| Interfaces - ARINC 429 | ARINC RX Port (x)<br>(x represents any available ARINC 429 Port) | Speed = Low<br>Format = EFIS/Air Data                                  |
|                        | ARINC TX Port 1                                                  | Speed = Low<br>Format = GAMA Format 1                                  |
|                        | SDI                                                              | LNAV1 (If GNX is #1 navigator)<br>Or<br>LNAV2 (If GNX is #2 navigator) |



| Config Page         | Config Option                                 | Configuration Setting |
|---------------------|-----------------------------------------------|-----------------------|
| Interfaces – RS-232 | Port (x)<br>(x represents RS-232 Port 1 or 2) | MapMX (Format 1)      |
|                     |                                               |                       |

Note 1: Set configuration values and units to match the values indicated in the appropriate AFM and document settings in the space provided.

Note 2: If the aircraft has no AFM set the values as determined by the existing placards, instrument bugs or instrument markings.

Note 3: Existing placards related to airspeed limitations must be retained.

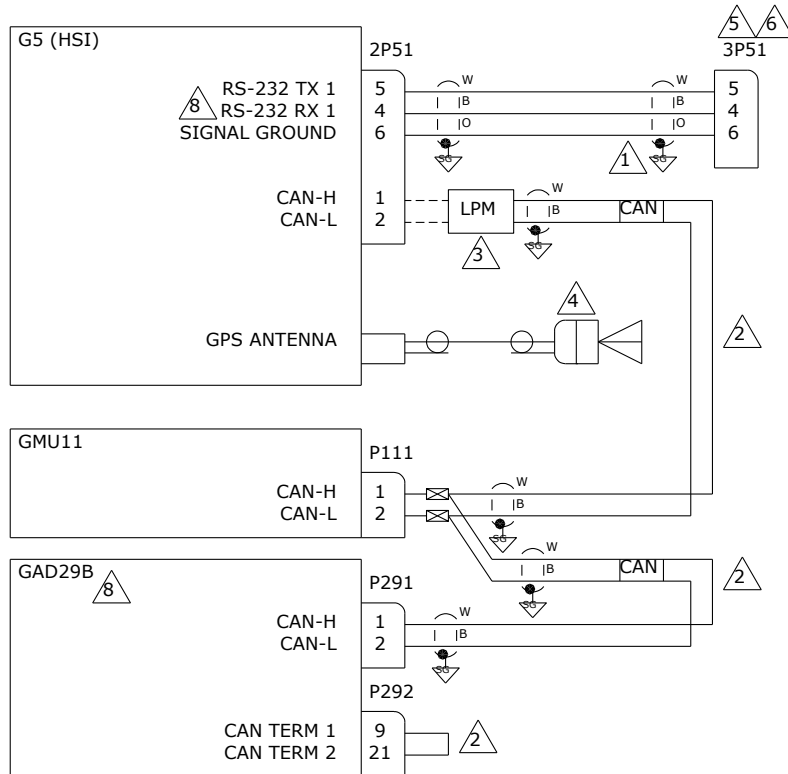
Note 4: Setting can remain at default setting, not supported in this configuration.

Note 5: The “Selected Course” will display when only one navigator is interfaced to the G5.

Note 6: “Selected Course 1” and “Selected Course 2” will display when dual navigators are interfaced.

*This area intentionally blank*

## 5.20 G5 Portable Avionics Unit Interface



- 1 TERMINATE SHIELD GROUNDS TO CONNECTOR BACKSHELL. SHIELD LEADS MUST BE MAX 3.0 INCHES.
- 2 CAN BUS LRUS MAY BE IN ANY ORDER ALONG BACKBONE AS LONG AS CAN BUS BACKBONE STRUCTURE GUIDELINES ARE FOLLOWED. REFER TO THE CAN BUS TERMINATION SECTION FOR FURTHER CAN BUS INFORMATION.
- 3 REFERENCE LIGHTNING PROTECTION MODULE (LPM) WIRING INTERFACE INTERCONNECT FOR DETAILED INSTALLATION REQUIREMENTS OF THE LPM.
- 4 CONNECTION TO A GPS ANTENNA REQUIRED. PORTABLE AVIONIC DEVICES ARE NOT QUALIFIED TO PROVIDE GPS DATA FOR ATTITUDE AIDING IN G5 INSTALLATIONS. THE GLARE SHIELD MOUNTED GPS ANTENNA P/N 011-04036-00 REQUIRES A BNC/TNC ADAPTER P/N 330-01754-00 FOR CONNECTION TO THE G5.
- 5 DISCONNECT CONNECTOR TO BE CONSTRUCTED OF THE FOLLOWING PARTS:
  1. P/N 330-00184-09, 9-PIN SOCKET CONNECTOR (QTY: 1)
  2. P/N 336-00022-00, 20 GA SOCKET (QTY: 3)
  3. P/N 011-00950-00, BACKSHELL KIT (QTY: 1)
  4. P/N 214-00023-11, STANDOFFS (QTY: 2)
- 6 REFER TO SECTION 4.1.8 FOR INSTALLATION AND ELECTRICAL BONDING GUIDANCE OF THE PANEL MOUNT CONNECTOR 3P51.
- 7 THE GLARE SHIELD MOUNTED GPS ANTENNA P/N 011-04036-00 REQUIRES A BNC/TNC ADAPTER P/N 330-01754-00 FOR CONNECTION TO THE G5.
- 8 GAD29B IS INSTALLED WHEN INTERFACING TO AN AUTOPILOT. FOR NON-GARMIN AUTOPILOT INTERCONNECTS, SEE GAD29B INTERFACE TO A NON-GARMIN AUTOPILOT INTERCONNECT DIAGRAMS FOR FURTHER INFORMATION.

**Figure 5-24 G5 Portable Avionics Unit Interface**



## 5.20.1 HSI Configuration

| Config Page                                                       | Config Option                | Configuration Setting                                                                                         |                    |
|-------------------------------------------------------------------|------------------------------|---------------------------------------------------------------------------------------------------------------|--------------------|
| Device Information                                                | Installation Type            | Certified Instrument                                                                                          |                    |
|                                                                   | Diagnostics/Data Log         | Enabled                                                                                                       |                    |
| Attitude Configuration                                            | Indicator Type               | Normal                                                                                                        |                    |
|                                                                   | Pitch Display                | Normal                                                                                                        |                    |
|                                                                   | Roll Display                 | For Fixed Type Pointers G5 Config = Ground Pointer<br>or<br>For Movable Type Pointers G5 Config = Sky Pointer |                    |
|                                                                   | Standard Turn Roll Reference | Hide                                                                                                          |                    |
|                                                                   | Automatic Declutter          | Disabled                                                                                                      |                    |
| Air Data                                                          | Air Data Sensors             | Enabled                                                                                                       |                    |
|                                                                   | Outside Air Temp Sensor      | Enabled<br><b>Note: if a GAD 13 is not installed, select Disabled</b>                                         |                    |
|                                                                   | Vertical Speed Indicator     | (1)(2)                                                                                                        |                    |
| Airspeed<br><br>Note: Configure Units prior to setting airspeeds. | VNE                          | (1)(2)(3)                                                                                                     |                    |
|                                                                   | VNO                          | (1)(2)(3)                                                                                                     |                    |
|                                                                   | VSO                          | (1)(2)(3)                                                                                                     |                    |
|                                                                   | VS1                          | (1)(2)(3)                                                                                                     |                    |
|                                                                   | VFE                          | (1)(2)(3)                                                                                                     |                    |
|                                                                   | VA                           | (1)(2)(3)                                                                                                     |                    |
|                                                                   | VX                           | (1)(2)(3)                                                                                                     |                    |
|                                                                   | VY                           | (1)(2)(3)                                                                                                     |                    |
|                                                                   | VG                           | (1)(2)(3)                                                                                                     |                    |
|                                                                   | VR                           | (1)(2)(3)                                                                                                     |                    |
|                                                                   | VMC                          | (1)(2)(3)                                                                                                     |                    |
| VYSE                                                              | (1)(2)(3)                    |                                                                                                               |                    |
| Magnetometer                                                      | Magnetometer                 | Enabled                                                                                                       |                    |
|                                                                   | Orientation                  | Connector Aft<br>Or<br>Connector Forward<br>Or<br>Connector Port<br>Or<br>Connector Starboard                 |                    |
| Flight Controls                                                   | Garmin Autopilot Servos      | None                                                                                                          |                    |
|                                                                   | Analog Autopilot Interface   | None<br>Or<br>See Section 5.24 if a Non-Garmin Autopilot is interfaced                                        |                    |
| Backlight                                                         | Current Mode                 | Automatic                                                                                                     |                    |
|                                                                   | Default Mode                 | Automatic                                                                                                     |                    |
|                                                                   | Minimum Photocell Input      | Default                                                                                                       |                    |
|                                                                   | Minimum Display Brightness   | Default                                                                                                       |                    |
|                                                                   | Maximum Photocell Input      | Default                                                                                                       |                    |
|                                                                   | Maximum Display Brightness   | Default                                                                                                       |                    |
| Display                                                           | Filter Time Constant         | Default                                                                                                       |                    |
|                                                                   | HSI Page                     | Enabled                                                                                                       |                    |
|                                                                   |                              | Power Up Page                                                                                                 | HSI                |
|                                                                   | Battery                      | Show Battery Status                                                                                           | When Using Battery |
|                                                                   |                              | Automatic Power Off                                                                                           | On Ground Only     |
|                                                                   | GPS                          | Internal GPS Receiver                                                                                         | Enabled            |
|                                                                   |                              | GPS Data Fields                                                                                               | Show               |





| Config Page             | Config Option        | Configuration Setting                                                                                                  |
|-------------------------|----------------------|------------------------------------------------------------------------------------------------------------------------|
| Navigation              | Navigation Data      | Enabled<br><b>Note: If an autopilot interface is configured, this configuration page is set to ENABLED by default.</b> |
|                         | Selected Course      | Enabled                                                                                                                |
|                         | VNAV Deviation Scale | (4)                                                                                                                    |
| Units                   | Altitude             | (1)(2)                                                                                                                 |
|                         | Distance             | (1)(2)                                                                                                                 |
|                         | Airspeed             | (1)(2)(3)                                                                                                              |
|                         | Ground Speed         | (1)(2)                                                                                                                 |
|                         | Navigation Angle     | Magnetic                                                                                                               |
|                         | Vertical Speed       | (1)(2)                                                                                                                 |
|                         | Pressure             | (1)(2)                                                                                                                 |
| RS-232                  | Input Format         | NMEA                                                                                                                   |
|                         | Output Format        | NMEA                                                                                                                   |
|                         | Baud Rate            | 4800                                                                                                                   |
| ARINC 429               | Output 1             | None                                                                                                                   |
|                         | Output 2             | None                                                                                                                   |
|                         | Input 1              | None                                                                                                                   |
|                         | Input 2              | None                                                                                                                   |
|                         | Input 3              | None                                                                                                                   |
|                         | Input 4              | None                                                                                                                   |
| Exit Configuration Mode |                      |                                                                                                                        |

Note 1: Set configuration values and units to match the values indicated in the appropriate AFM and document settings in the space provided.

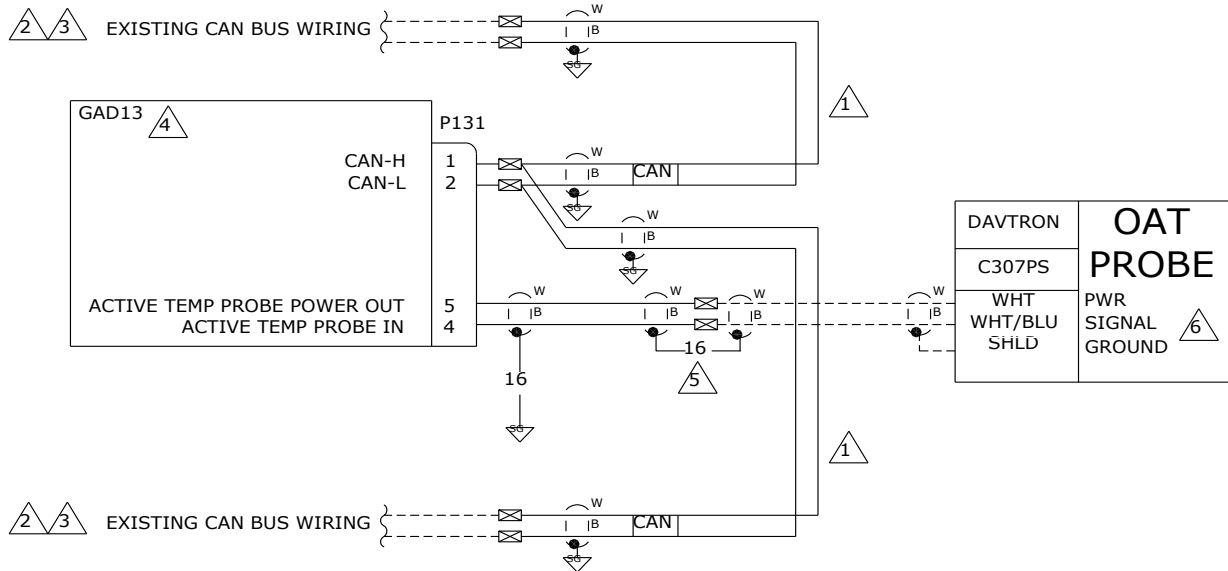
Note 2: If the aircraft has no AFM set the values as determined by the existing placards, instrument bugs or instrument markings.

Note 3: Existing placards related to airspeed limitations must be retained.

Note 4: Setting can remain at default setting, not supported in this configuration.

*This area intentionally blank*

## 5.21 GAD 13 Interface



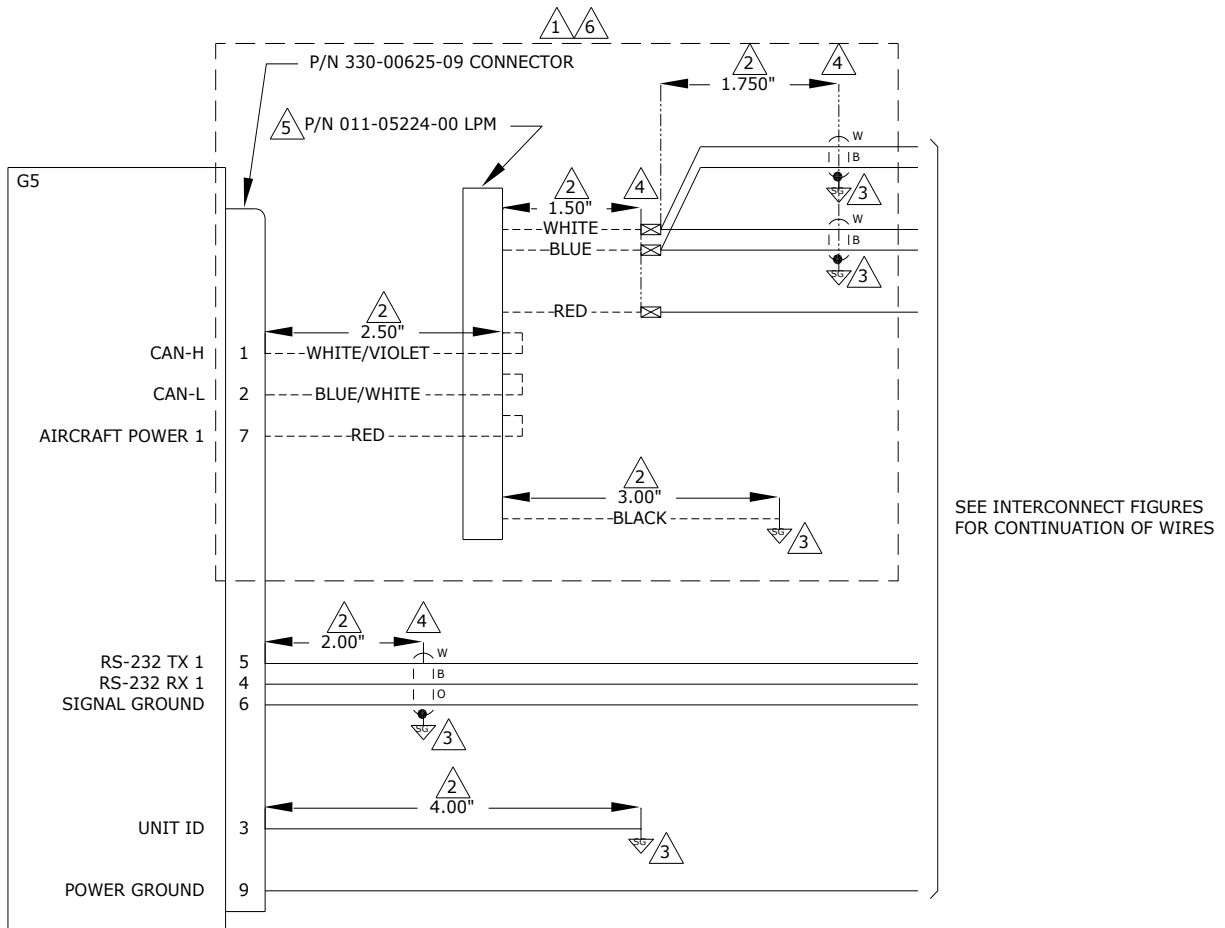
- 1 CAN BUS LRUS MAY BE IN ANY ORDER ALONG BACKBONE AS LONG AS CAN BUS BACKBONE STRUCTURE GUIDELINES ARE FOLLOWED. REFER TO THE CAN BUS TERMINATION SECTION FOR FURTHER CAN BUS INFORMATION.
- 2 IF INSTALLING GAD13 ON A PREVIOUSLY INSTALLED CAN BUS, CONNECT TO THE EXISTING CAN BUS USING GUIDELINES IN SECTION 3.4. IF THE GAD13 IS INSTALLED AS THE TERMINATOR OF A CAN BUS, CAN BUS TERMINATOR P/N 011-02887-00 MUST BE INSTALLED ON CONNECTOR P131.
- 3 IF INSTALLING THE GAD13 AS PART OF A NEW G5 INSTALLATION, REFERENCE THE APPROPRIATE INTERCONNECT DIAGRAM FOR COMPLETE WIRING OF THE CAN BUS. FOLLOW GUIDELINES IN SECTION 3.4 FOR CAN BUS INSTALLATION PROCEDURES.
- 4 GAD13 INSTALLED TO PROVIDE OAT INFORMATION TO THE G5 SYSTEM.
- 5 IF EXISTING WIRE IS NOT LONG ENOUGH TO REACH THE GAD13 THEN CRIMP NEW WIRE TO EXISTING WIRES AS SHOWN. THE SHIELD OF THE TWISTED SHIELDED WIRE SHALL BE CARRIED THROUGH AND TERMINATED USING 16 AWG WIRE THAT HAS A MAXIMUM LENGTH OF 3.5 INCHES.
- 6 FOR GTP59 WIRING, REFER TO POWER AND GROUND FIGURE.

**Figure 5-25 GAD 13 Interface**

### 5.21.1 ADI or HSI Configuration

| Config Page             | Config Option                  | Configuration Setting                                                                |
|-------------------------|--------------------------------|--------------------------------------------------------------------------------------|
| Air Data                | Outside Air Temperature Sensor | Enabled                                                                              |
| Units                   | Temperature                    | Set configuration units to match the values indicated in the appropriate AFM or POH. |
| Exit Configuration Mode |                                |                                                                                      |

## 5.22 Lightning Protection Module (LPM) Wiring Interface



- 1 DASHED WIRES SHOWN ARE PRE-INSTALLED WIRES IN THE LPM ASSEMBLY 011-05224-00.
- 2 DIMENSIONS SHOWN ARE MAXIMUM LENGTHS.
- 3 SHIELD GROUNDS/UNIT ID WIRE ARE GROUNDED TO THE BACKSHELL OF THE LPM ASSEMBLY 011-05224-00.
- 4 DIMENSIONS SHOWN FOR SHIELD GROUNDS ARE MEASURED FROM CONNECTOR/SPLICE END TO BEGINNING OF SOLDER SLEEVE.
- 5 REFER TO SECTION 4 FOR DETAILED CONNECTOR BUILDUP USING THE LPM.
- 6 INSTALLATION OF THE LPM IS ACCEPTABLE IN LIEU OF THE REQUIREMENTS FOR THE INSTALLATION OF RESISTORS AND DIODE STATED IN "ELECTRICAL BONDING AND CONNECTIONS" STATED IN THE G3X CERTIFIED INSTALLATION MANUAL, 190-02472-01 APPENDIX E

**Figure 5-26 Lightning Protection Module (LPM) Wiring Interface**



## **5.23 GAD 29B Interface to Garmin Autopilots**

### **5.23.1 GAD 29B Interface to Garmin GFC 600 Autopilot**

For configuration of a G5 when interfaced to a Garmin GFC 600 autopilot, see GFC 600 AFCS Installation Manual, 190-01937-00.

#### **5.23.1.1 G5 Configuration GFC 600 Autopilots**

For configuration of a G5 when interfaced to a Garmin GFC 600 autopilot, see GFC 600 AFCS Installation Manual, 190-01937-00.

### **5.23.2 GAD 29B Interface to Garmin GFC 500 Autopilot**

For information regarding interface of a GAD 29B to a GFC 500 autopilot, see GFC 500 AFCS Installation Manual, 190-02291-00.

#### **5.23.2.1 G5 Configuration GFC 500 Autopilots**

For configuration of a G5 when interfaced to a Garmin GFC 500 autopilot, see GFC 500 AFCS Installation Manual, 190-02291-00.

*This area intentionally blank*



## 5.24 GAD 29B Interface to Non-Garmin Autopilots

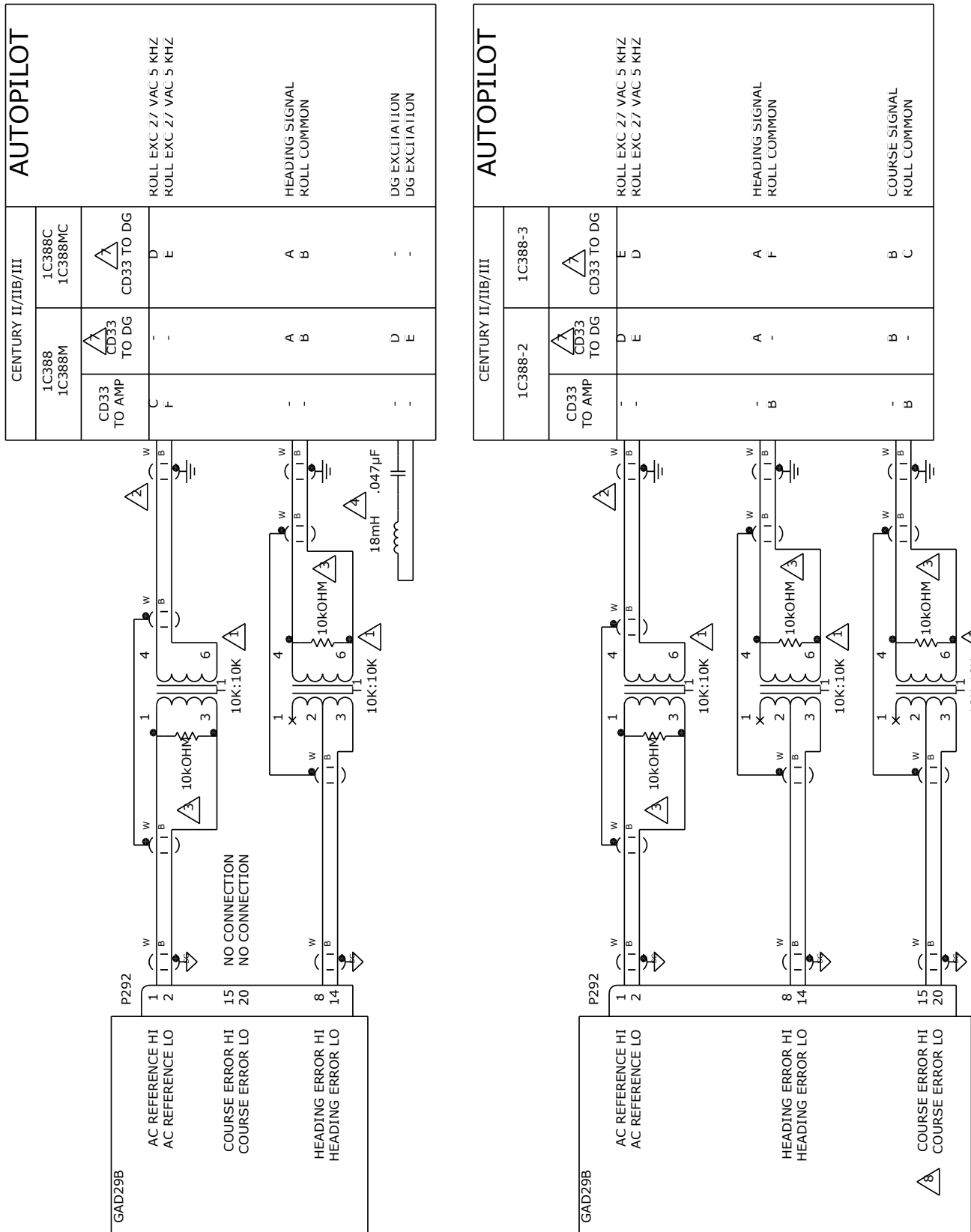
This section only applies to installations using a GAD 29B data converter and an interface to one of the autopilots listed in Table 5-1. Specific configuration details are covered in the following sections.

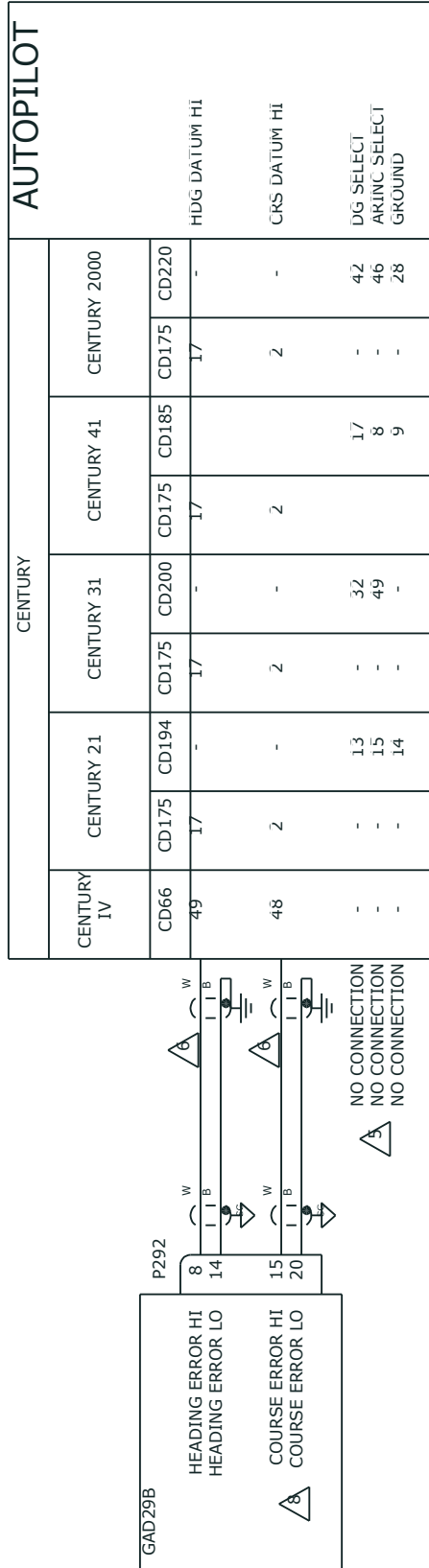
**Table 5-1: Non-Garmin Autopilots**

| Autopilot Mfg            | Autopilot Model                                                                                                 |
|--------------------------|-----------------------------------------------------------------------------------------------------------------|
| Century                  | Century 1C388*                                                                                                  |
|                          | Century 1C388M*                                                                                                 |
|                          | Century 1C388C*                                                                                                 |
|                          | Century 1C388MC*                                                                                                |
|                          | Century 1C388-2*                                                                                                |
|                          | Century 1C388-3*                                                                                                |
|                          | Century 2000                                                                                                    |
|                          | Century 21                                                                                                      |
|                          | Century 31                                                                                                      |
|                          | Century 41                                                                                                      |
|                          | Century IV                                                                                                      |
|                          | * Radio Coupler P/N indicated and based on aircraft installation could be interfaced in a Century II(B) or III. |
| Cessna                   | Cessna 300, 400 & 800 IFCS                                                                                      |
|                          | Cessna 300B, 400B & 800B IFCS                                                                                   |
| Honeywell (Bendix /King) | Bendix King KAP 100                                                                                             |
|                          | Bendix King KAP 140                                                                                             |
|                          | Bendix King KAP 150                                                                                             |
|                          | Bendix King KAP 200                                                                                             |
|                          | Bendix King KFC 150                                                                                             |
|                          | Bendix King KFC 200                                                                                             |
|                          | Bendix King KFC 225                                                                                             |
| S-TEC                    | S-TEC System 20                                                                                                 |
|                          | S-TEC System 30                                                                                                 |
|                          | S-TEC System 40                                                                                                 |
|                          | S-TEC System 50                                                                                                 |
|                          | S-TEC System 55                                                                                                 |
|                          | S-TEC System 55X                                                                                                |
|                          | S-TEC System 60                                                                                                 |
|                          | S-TEC System 65                                                                                                 |
| Piper                    | Piper Altimatic III                                                                                             |
|                          | Piper Altimatic IIIB                                                                                            |
|                          | Piper Altimatic IIIC                                                                                            |
|                          | Piper Autocontrol III                                                                                           |
|                          | Piper Autocontrol IIIB-1                                                                                        |
|                          | Piper Autocontrol IIIC                                                                                          |

*This area intentionally blank*

## 5.24.1 GAD 29B Interface to Century Autopilots





- A USE MIL-T-27 TYPE TF5S21ZZ TRANSFORMER TRIAD MAGNETICS P/N SP-66. REFER TO GAD29B TRANSFORMER MOUNTING INSTRUCTIONS FOR TRANSFORMER MOUNTING AND INSTALLATION INSTRUCTIONS.
- A SPLICE NEW WIRING TO EXISTING WIRING AT RADIO COUPLER.
- 3 USE MIL-R-10509 TYPE RN RESISTOR VISHAY P/N RN60D1002FB14. SEE SECTION 3.4 FOR EXAMPLE INSTRUCTIONS ON HOW TO INSTALL THIS RESISTOR.
- 4 USE CENTURY TANK CIRCUIT (CENTURY P/N 24A93) OR INDUCTOR JW MILLER P/N 8250-183K-RC AND MIL-PRF-39014 CAPACITOR KEMET P/N CKR05BX473M OR EQUIVALENT. SEE SECTION 3.4 FOR EXAMPLE INSTRUCTIONS ON HOW TO INSTALL THIS RESISTOR.
- 5 WHEN INTERFACING WITH A CENTURY 31/41/2000 A/P, REMOVE ALL JUMPERS AT PINS NOTED IN THE TABLE.
- 6 EXISTING WIRING MAY BE RE-USED IF WIRE LENGTH IS SUFFICIENT TO REACH GAD29B.
- 7 FOR CONNECTIONS TO "CD33 TO DG" PIGTAIL AT RADIO COUPLER, BUILD MATING CONNECTOR USING P/N 126-217-1000.
- 8 COURSE ERROR OUT IS ONLY CONNECTED WHEN THE G5 IS INTERFACING WITH A GARMIN NAVIGATOR.

**Figure 5-28 GAD 29B Interface to Century Autopilots, Sheet 2 of 2**



### 5.24.1.1 G5 Configuration Century Autopilots

**Note:** The Flight Controls Configuration shown below only needs to be set on the master G5. In a single installation the master must be the G5 DG/HSI. In a dual installation the master is the G5 Attitude indicator.

| Config Page                                                                                                                                                                                                                                                                                                             | Config Option              | Configuration Setting               |                  | Interfacing Equipment Configuration Information          |
|-------------------------------------------------------------------------------------------------------------------------------------------------------------------------------------------------------------------------------------------------------------------------------------------------------------------------|----------------------------|-------------------------------------|------------------|----------------------------------------------------------|
| Flight Controls                                                                                                                                                                                                                                                                                                         | Analog Autopilot Interface | <b>AP Model / Radio Coupler P/N</b> | <b>G5 Config</b> | <b>Century A/P Config</b>                                |
|                                                                                                                                                                                                                                                                                                                         |                            | 1C388                               | Century 1C388    | As per the wiring interface in Figure 5-27 & Figure 5-28 |
|                                                                                                                                                                                                                                                                                                                         |                            | 1C388-2                             | Century 1C388-2  |                                                          |
|                                                                                                                                                                                                                                                                                                                         |                            | 1C388-3                             | Century 1C388-3  |                                                          |
|                                                                                                                                                                                                                                                                                                                         |                            | 1C388C                              | Century 1C388C   |                                                          |
|                                                                                                                                                                                                                                                                                                                         |                            | 1C388M                              | Century 1C388M   |                                                          |
|                                                                                                                                                                                                                                                                                                                         |                            | 1C388MC                             | Century 1C388MC  |                                                          |
|                                                                                                                                                                                                                                                                                                                         |                            | Century 2000                        | Century 2000     |                                                          |
|                                                                                                                                                                                                                                                                                                                         |                            | Century 21                          | Century 21       |                                                          |
|                                                                                                                                                                                                                                                                                                                         |                            | Century 31                          | Century 31       |                                                          |
|                                                                                                                                                                                                                                                                                                                         |                            | Century 41                          | Century 41       |                                                          |
|                                                                                                                                                                                                                                                                                                                         | Century IV (DC)            | Century IV                          |                  |                                                          |
|                                                                                                                                                                                                                                                                                                                         |                            | GPS Steering*                       | Enabled          |                                                          |
|                                                                                                                                                                                                                                                                                                                         | GPSS Scale Factor*         | 1.00**                              |                  | ---                                                      |
| * GPS Steering and GPSS Scale Factor is configured the same for all listed Analog Autopilot interfaces<br>** If the autopilot does not turn tightly enough while roll steering, increase the GPSS Scale Factor setting. If the autopilot turns too tightly while roll steering, decrease the GPSS Scale Factor setting. |                            |                                     |                  | ---                                                      |

*This area intentionally blank*



## 5.24.2 GAD 29B Interface to Cessna Autopilots

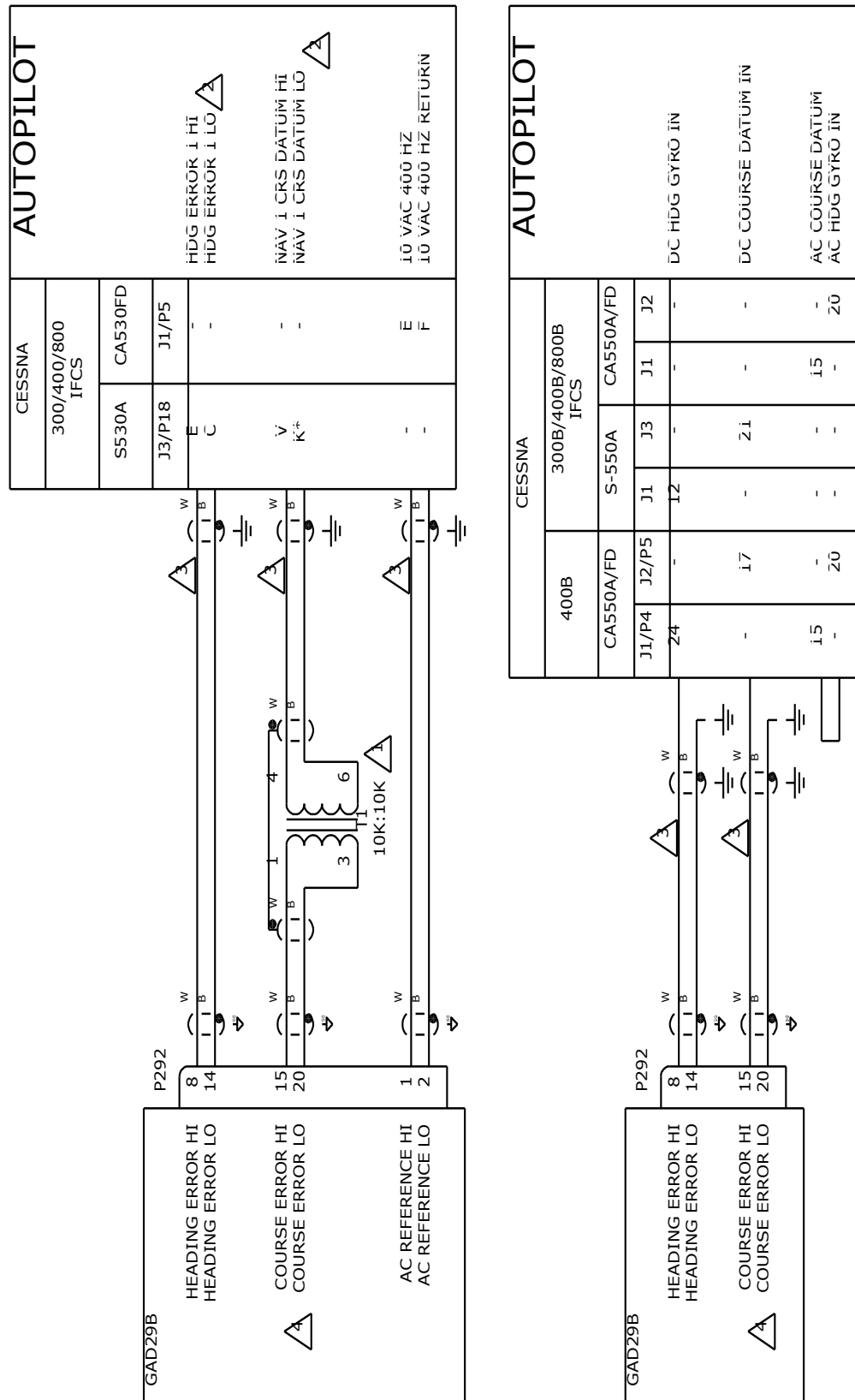


Figure 5-29 GAD 29B Interface to Cessna Autopilots

- ⚠️ USE MIL-T-27 TYPE TF5S21ZZ TRANSFORMER TRIAD MAGNETICS P/N SP-66. REFER TO GAD29B TRANSFORMER MOUNTING INSTRUCTIONS FOR TRANSFORMER MOUNTING AND INSTALLATION INSTRUCTIONS.
- ⚠️ TUNE RESISTANCE POTS ON HEADING ERROR HI AND COURSE ERROR HI TO END OF TRAVEL IN ORDER NOT TO AFFECT THE HEADING AND COURSE ERROR SIGNALS. REFER TO CESSNA 300/400/800 IFCS MAINTENANCE MANUAL FOR FURTHER INFORMATION.
- ⚠️ EXISTING WIRING MAY BE RE-USED IF WIRE LENGTH IS SUFFICIENT TO REACH GAD29B.
- ⚠️ COURSE ERROR OUT IS ONLY CONNECTED WHEN THE G5 IS INTERFACING WITH A GARMIN NAVIGATOR.



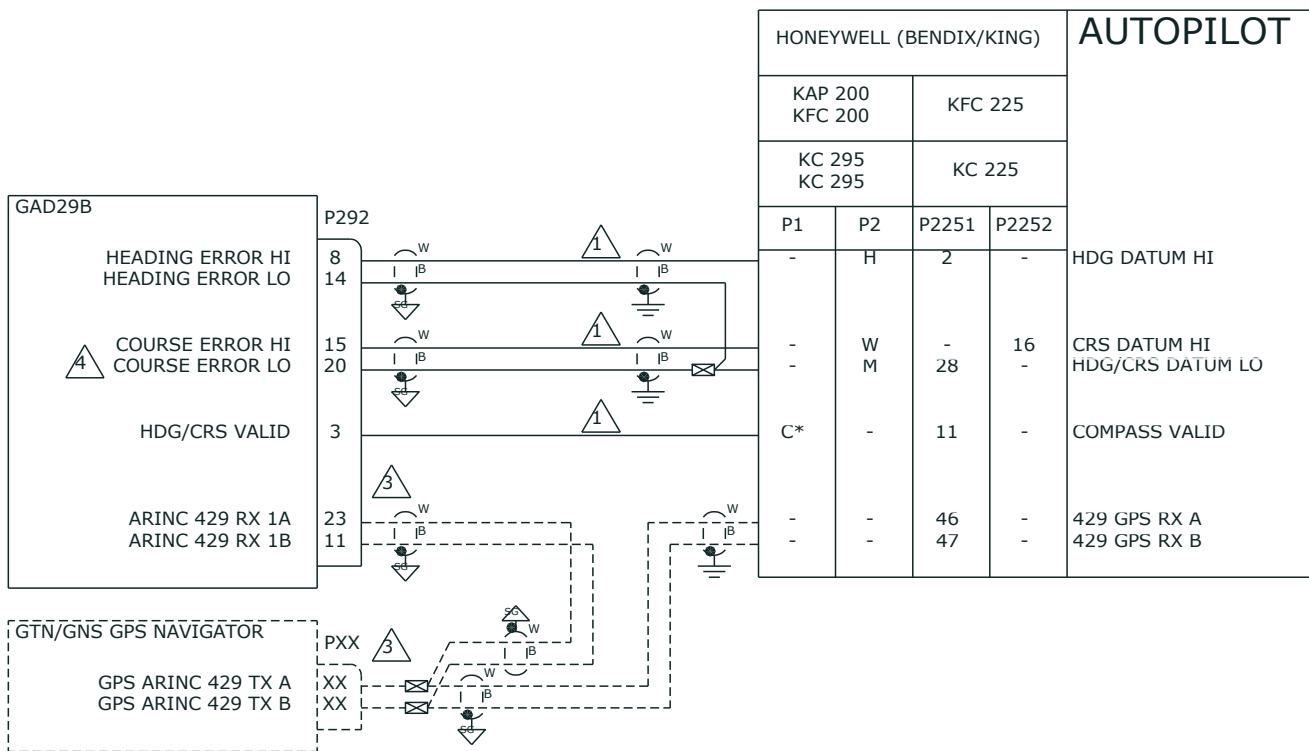
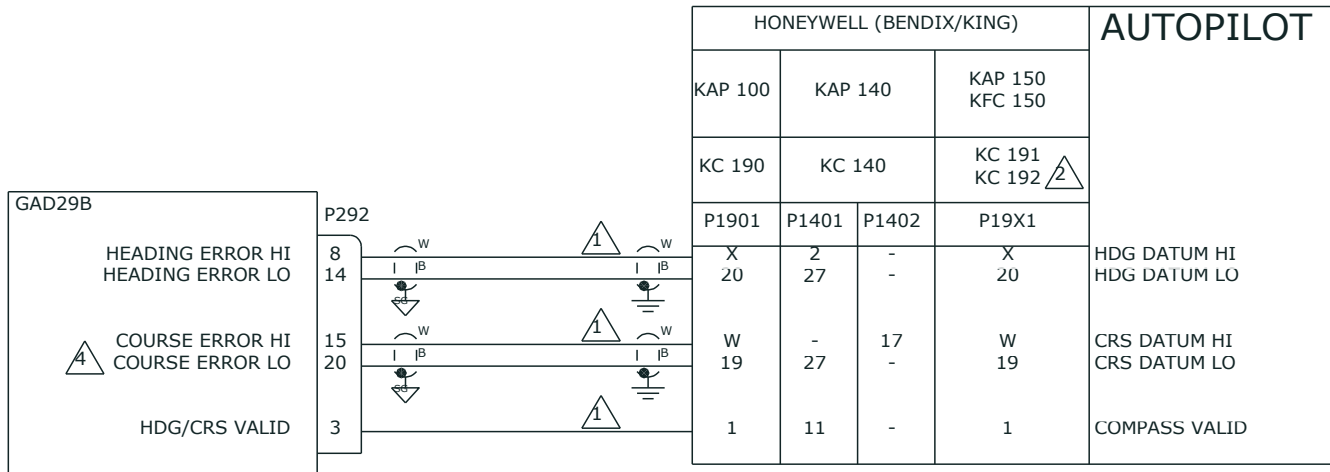
### 5.24.2.1 G5 Configuration Cessna Autopilots

**Note:** The Flight Controls Configuration shown below only needs to be set on the master G5. In a single installation the master is the only G5 indicator installed. In a dual installation the master is the G5 Attitude indicator.

| Config Page                                                                                                                                                                                                                                                                                                             | Config Option              | Configuration Setting   |                  | Interfacing Equipment Configuration Information                 |
|-------------------------------------------------------------------------------------------------------------------------------------------------------------------------------------------------------------------------------------------------------------------------------------------------------------------------|----------------------------|-------------------------|------------------|-----------------------------------------------------------------|
| Flight Controls                                                                                                                                                                                                                                                                                                         | Analog Autopilot Interface | <b>AP Model</b>         | <b>G5 Config</b> | Cessna A/P Config<br><br>As per wiring interface in Figure 5-29 |
|                                                                                                                                                                                                                                                                                                                         |                            | Cessna 300 IFCS         | Cessna 300 (AC)  |                                                                 |
|                                                                                                                                                                                                                                                                                                                         |                            | Cessna 400 & 800 IFCS   | Cessna 400 (AC)  |                                                                 |
|                                                                                                                                                                                                                                                                                                                         |                            | Cessna 300B IFCS        | Cessna 300 (DC)  |                                                                 |
|                                                                                                                                                                                                                                                                                                                         |                            | Cessna 400B & 800B IFCS | Cessna 400 (DC)  |                                                                 |
|                                                                                                                                                                                                                                                                                                                         | GPS Steering*              | Enabled                 |                  | ---                                                             |
| GPSS Scale Factor*                                                                                                                                                                                                                                                                                                      | 1.00**                     |                         |                  |                                                                 |
| * GPS Steering and GPSS Scale Factor is configured the same for all listed Analog Autopilot interfaces<br>** If the autopilot does not turn tightly enough while roll steering, increase the GPSS Scale Factor setting. If the autopilot turns too tightly while roll steering, decrease the GPSS Scale Factor setting. |                            |                         |                  |                                                                 |

*This area intentionally blank*

## 5.24.3 GAD 29B Interface to Honeywell Autopilots



- <sup>1</sup> EXISTING WIRING MAY BE RE-USED IF WIRE LENGTH IS SUFFICIENT TO REACH GAD29B.
- <sup>2</sup> EFIS-ENABLED KC 19X COMPUTER (P/N 065-0042-16) IS NOT SUPPORTED.
- <sup>3</sup> SEE GAD29B INTERFACE TO GPS/VHF NAVIGATOR FIGURES.
- <sup>4</sup> COURSE ERROR OUT IS ONLY CONNECTED WHEN THE G5 IS INTERFACING WITH A GARMIN NAVIGATOR.

**Figure 5-30 GAD 29B Interface to Honeywell Autopilots**



### 5.24.3.1 G5 Configuration Honeywell (Bendix King) Autopilots

**Note:** The Flight Controls Configuration shown below only needs to be set on the master G5. In a single installation the master is the only G5 indicator installed. In a dual installation the master is the G5 Attitude indicator.

| Config Page                                                                                                                                                                                                                                                                                                                                                                                              | Config Option              | Configuration Setting |                                                                                                                        | Interfacing Equipment Configuration Information                                                         |
|----------------------------------------------------------------------------------------------------------------------------------------------------------------------------------------------------------------------------------------------------------------------------------------------------------------------------------------------------------------------------------------------------------|----------------------------|-----------------------|------------------------------------------------------------------------------------------------------------------------|---------------------------------------------------------------------------------------------------------|
| Flight Controls                                                                                                                                                                                                                                                                                                                                                                                          | Analog Autopilot Interface | <b>AP Model</b>       | <b>G5 Config</b>                                                                                                       | <b>KAP/KFC A/P Config</b><br><br>Must be configured to operate with the KI-525 (KCS-55) heading system. |
|                                                                                                                                                                                                                                                                                                                                                                                                          |                            | KAP 100               | Bendix King KAP 100                                                                                                    |                                                                                                         |
|                                                                                                                                                                                                                                                                                                                                                                                                          |                            | KAP 140               | Bendix King KAP 140                                                                                                    |                                                                                                         |
|                                                                                                                                                                                                                                                                                                                                                                                                          |                            | KAP 150               | Bendix King KAP 150                                                                                                    |                                                                                                         |
|                                                                                                                                                                                                                                                                                                                                                                                                          |                            | KAP 200               | Bendix King KAP 200                                                                                                    |                                                                                                         |
|                                                                                                                                                                                                                                                                                                                                                                                                          |                            | KFC 150               | Bendix King KFC 150                                                                                                    |                                                                                                         |
|                                                                                                                                                                                                                                                                                                                                                                                                          |                            | KFC 200               | Bendix King KFC 200                                                                                                    |                                                                                                         |
|                                                                                                                                                                                                                                                                                                                                                                                                          | KFC 225 **                 | Bendix King KFC 225   | Must be configured to operate with the KI-525 (KCS-55) heading system.<br><br>Must be configured for DC analog heading |                                                                                                         |
|                                                                                                                                                                                                                                                                                                                                                                                                          | GPS Steering*              | Enabled               |                                                                                                                        | ---                                                                                                     |
|                                                                                                                                                                                                                                                                                                                                                                                                          | GPSS Scale Factor*         | 1.00***               |                                                                                                                        | ---                                                                                                     |
| * GPS Steering and GPSS Scale Factor is configured the same for all listed Analog Autopilot interfaces except KFC 225<br>** GPS Steering is not an available configuration for KFC 225<br>*** If the autopilot does not turn tightly enough while roll steering, increase the GPSS Scale Factor setting. If the autopilot turns too tightly while roll steering, decrease the GPSS Scale Factor setting. |                            |                       |                                                                                                                        | ---                                                                                                     |

*This area intentionally blank*

## 5.24.4 GAD 29B Interface to S-TEC Autopilots

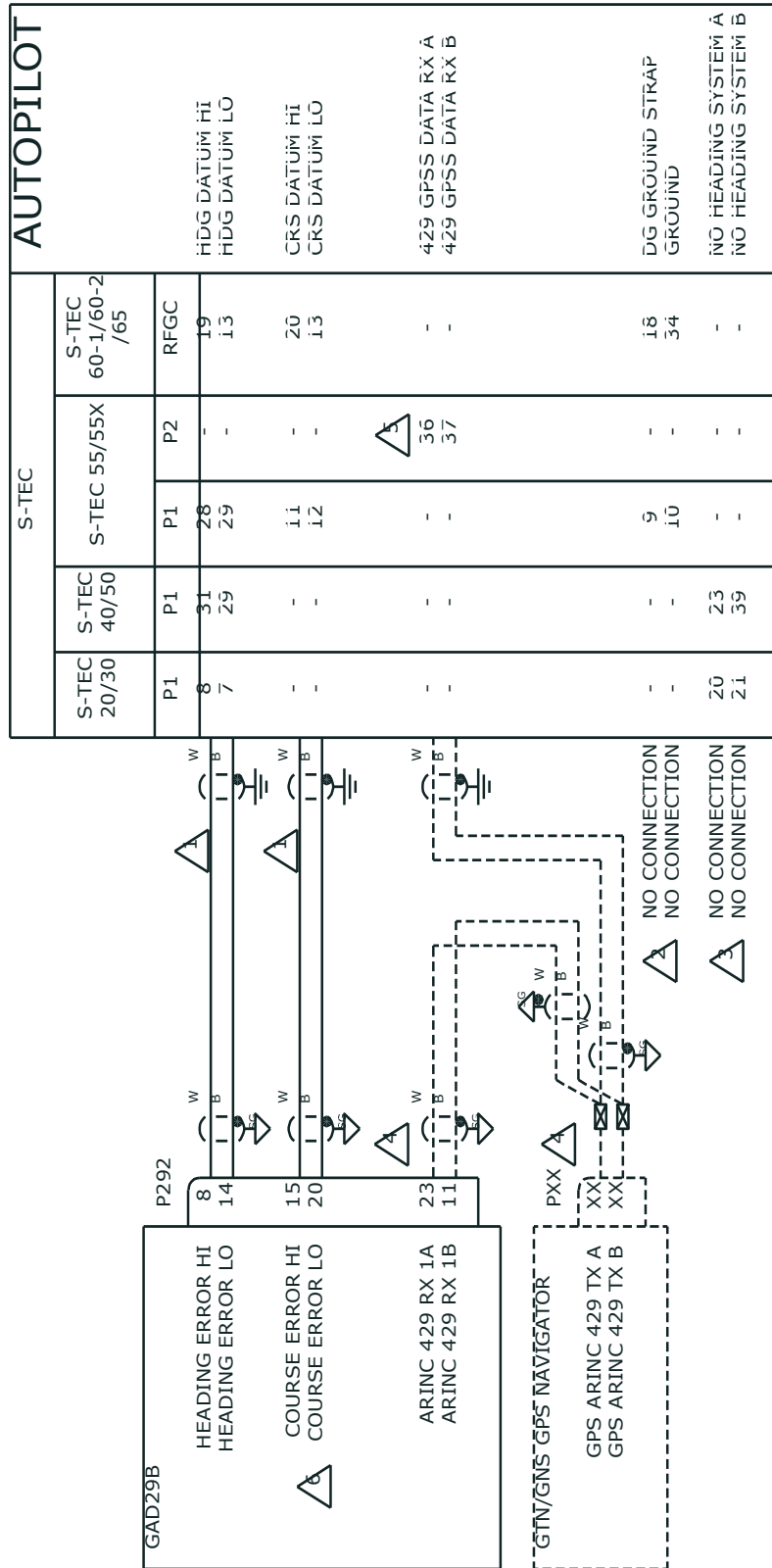


Figure 5-31 GAD 29B Interface to S-TEC Autopilots

- EXISTING WIRING MAY BE RE-USED IF WIRE LENGTH IS SUFFICIENT TO REACH GAD29B.
- REMOVE ALL JUMPERS FOR DG GROUND STRAP.
- REMOVE ALL JUMPERS FOR NO HEADING SYSTEM.
- SEE GAD29B INTERFACE TO GPS/VHF NAVIGATOR FIGURES.
- 429 GPSS DATA RX A/B APPLIES TO S-TEC 55X SYSTEM ONLY.
- COURSE ERROR OUT IS ONLY CONNECTED WHEN THE G5 IS INTERFACING WITH A GARMIN NAVIGATOR.



### 5.24.4.1 G5 Configuration S-TEC Autopilots

**Note:** The Flight Controls Configuration shown below only needs to be set on the master G5. In a single installation the master is the only G5 indicator installed. In a dual installation the master is the G5 Attitude indicator.

| Config Page     | Config Option              | Configuration Setting |                  | Interfacing Equipment Configuration Information                                                       |
|-----------------|----------------------------|-----------------------|------------------|-------------------------------------------------------------------------------------------------------|
| Flight Controls | Analog Autopilot Interface | <b>AP Model</b>       | <b>G5 Config</b> | <b>S-TEC A/P Config</b><br><br>Must be configured to operate with the KI-525 (KCS-55) heading system. |
|                 |                            | System 20             | S-TEC System 20  |                                                                                                       |
|                 |                            | System 30             | S-TEC System 30  |                                                                                                       |
|                 |                            | System 40             | S-TEC System 40  |                                                                                                       |
|                 |                            | System 50             | S-TEC System 50  |                                                                                                       |
|                 |                            | System 55             | S-TEC System 55  |                                                                                                       |
|                 |                            | System 55X**          | S-TEC System 55X |                                                                                                       |
|                 |                            | System 60             | S-TEC System 60  |                                                                                                       |
|                 | System 65                  | S-TEC System 65       |                  |                                                                                                       |
|                 |                            | GPS Steering*         | Enabled          |                                                                                                       |
|                 | GPSS Scale Factor*         | 1.00***               |                  |                                                                                                       |

\* GPS Steering and GPSS Scale Factor is configured the same for all listed Analog Autopilot interfaces except System 55X  
 \*\* GPS Steering is not an available configuration for System 55X  
 \*\*\* If the autopilot does not turn tightly enough while roll steering, increase the GPSS Scale Factor setting. If the autopilot turns too tightly while roll steering, decrease the GPSS Scale Factor setting.

*This area intentionally blank*

## 5.24.5 GAD 29B Interface to Piper Autopilots

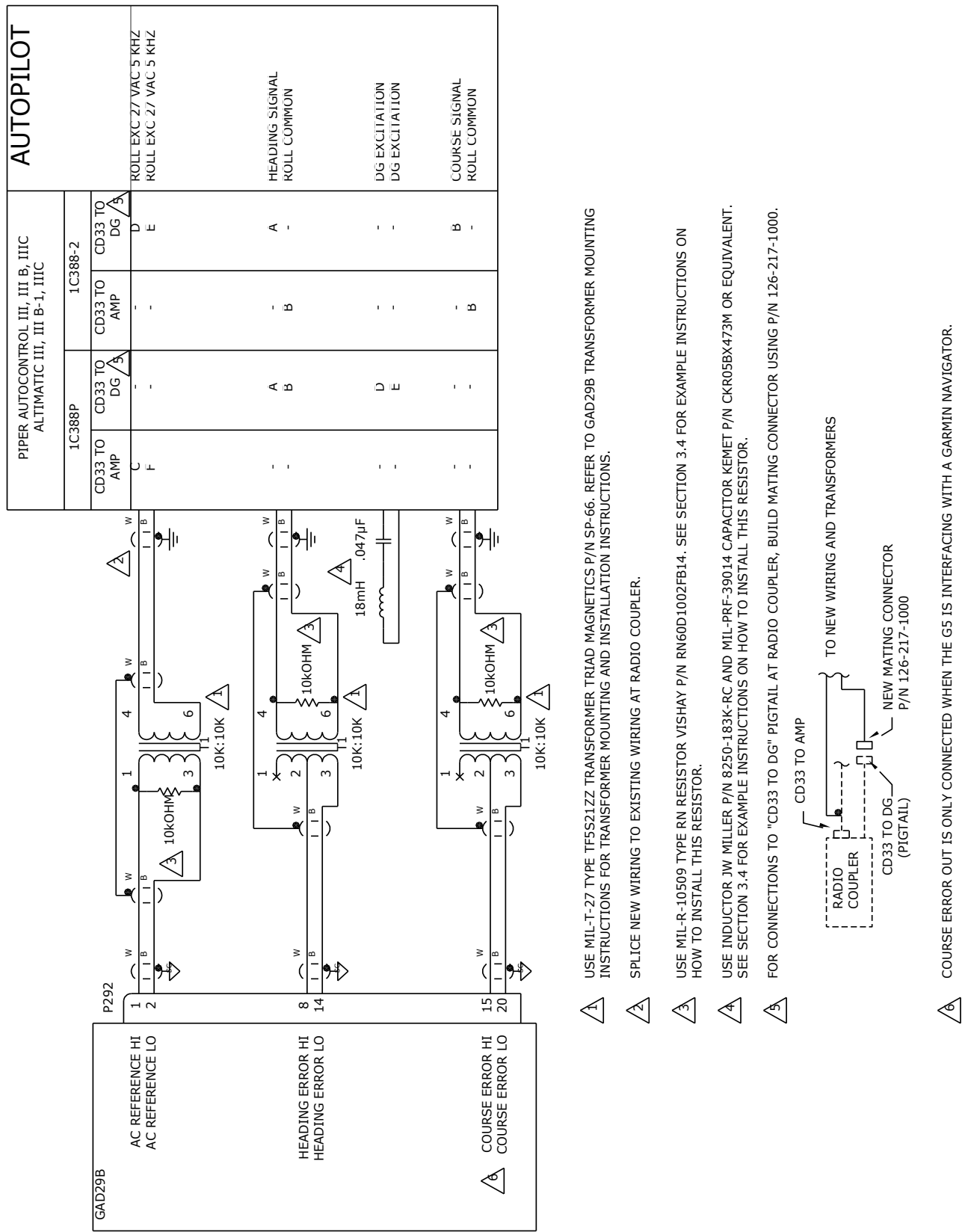


Figure 5-32 GAD 29B Interface To Piper Autopilots



### 5.24.5.1 G5 Configuration Piper Autopilots

**Note:** The Flight Controls Configuration shown below only needs to be set on the master G5. In a single installation the master must be the G5 DG/HSI. In a dual installation the master is the G5 Attitude Indicator.

| Config Page                                                                                                                                                                                                                                                                                                             | Config Option              | Configuration Setting               |                      | Interfacing Equipment Configuration Information |
|-------------------------------------------------------------------------------------------------------------------------------------------------------------------------------------------------------------------------------------------------------------------------------------------------------------------------|----------------------------|-------------------------------------|----------------------|-------------------------------------------------|
| Flight Controls                                                                                                                                                                                                                                                                                                         | Analog Autopilot Interface | <b>AP Model / Radio Coupler P/N</b> | <b>G5 Config</b>     | <b>Piper A/P Config</b>                         |
|                                                                                                                                                                                                                                                                                                                         |                            | Altimatec III                       | Piper Altimatec (AC) | As per the wiring interface in Figure 5-32      |
|                                                                                                                                                                                                                                                                                                                         |                            | Altimatec IIIB                      | Piper Altimatec (AC) |                                                 |
|                                                                                                                                                                                                                                                                                                                         |                            | Altimatec IIIC                      | Piper Altimatec (AC) |                                                 |
|                                                                                                                                                                                                                                                                                                                         |                            | Autocontrol III                     | Piper Autocontrol    |                                                 |
|                                                                                                                                                                                                                                                                                                                         |                            | Autocontrol IIIB-1                  | Piper Autocontrol    |                                                 |
|                                                                                                                                                                                                                                                                                                                         | Autocontrol IIIC           | Piper Autocontrol                   |                      |                                                 |
|                                                                                                                                                                                                                                                                                                                         | GPS Steering*              | Enabled                             |                      | ---                                             |
|                                                                                                                                                                                                                                                                                                                         | GPSS Scale Factor*         | 1.00**                              |                      | ---                                             |
| * GPS Steering and GPSS Scale Factor is configured the same for all listed Analog Autopilot interfaces<br>** If the autopilot does not turn tightly enough while roll steering, increase the GPSS Scale Factor setting. If the autopilot turns too tightly while roll steering, decrease the GPSS Scale Factor setting. |                            |                                     |                      | ---                                             |

*This area intentionally blank*





## 6 SYSTEM CONFIGURATION AND CHECKOUT PROCEDURES

### 6.1 Overview

This section contains instructions for configuration and checkout of the G5 Electronic Flight Instrument, GMU 11, GAD 29/29B/29D, and GAD 13. The steps which are not applicable to a particular installation may be skipped. A summary of the steps required for checkout of the G5 is as follows:

- Perform mounting, wiring, and power checks (see section 6.2)
- Configure the G5 (see Section 6.3)
- Perform post-installation checkout procedures (see Section 6.3)
- Perform documentation checks (see section 6.4)



#### NOTE

*Throughout the next sections, many screenshots and examples are used to illustrate the software loading and configuration and checkout process. Changes may occur which result in the examples being out of date.*

### 6.2 Mounting, Wiring, and Power Checks

Verify all wire harnesses are properly secured and shields are connected to the shield blocks of the connectors. Check the movement of the flight and engine controls to verify there is no interference. Prior to powering up the G5 and supporting equipment, the wire harnesses must be checked for proper connections to the aircraft systems and other avionics equipment. Point to point continuity must be checked on all wiring to expose any faults such as shorting to ground. Any faults or discrepancies must be corrected before proceeding.

After accomplishing a continuity check, perform power and ground checks. Remove power from the aircraft upon completion of the wire harness checkout.

The G5 and supporting equipment can be installed after completion of the continuity and power checks.

### 6.3 Post-Installation Checkout Procedures

The following procedures will verify the proper operation of the G5 and its intended function as an attitude indicator or DG/HSI. The G5 can be installed in several different configurations that affect the following testing. If a section of testing is not supported by the installed configuration disregard that testing. It is assumed that the person performing these checks is familiar with the aircraft, has a working knowledge of typical avionics systems, and has experience using the test equipment defined in this section.



#### NOTE

*For G5 operational instructions, see 190-01112-12, Pilot's Guide, Garmin G5 Electronic Flight Instrument, Part 23 AML STC.*

**NOTE**

*Some procedures in this section require that the GPS receiver is receiving sufficient satellite signal to compute a present position. This requires outdoor line-of-site to GPS satellite signals or a GPS indoor repeater.*

**NOTE**

*As these procedures involve engine run-up and moving the aircraft, it is recommended that the installer read this entire section before beginning the checkout procedure.*

**NOTE**

*All test equipment should have current calibration records.*

### 6.3.1 Recommended Test Equipment

The following test equipment is recommended to conduct and complete all post installation checkout procedures in this section:

- Pitot/static ramp tester
- Digital Multi-Meter (DMM)
- Ground power unit capable of supplying 14/28 Vdc power to the aircraft systems and avionics
- Outdoor line-of-sight to GPS satellite signals or GPS indoor repeater
- Digital Level or equivalent
- VHF NAV Test Set

### 6.3.2 Configuration Mode

All of the configuration and calibration procedures in this section are performed in configuration mode. To enter configuration mode, hold down the knob while powering on the G5. Configuration selections are made by rotating and pressing the knob on the face of the G5 as necessary to select the correct configurations.

### 6.3.3 Software Loader Card Creation

The software image is an executable self-extracting file which builds the correct file structure onto a microSD card for use loading software to all installed G5's. To obtain the current software image is an executable self-extracting file follow the procedures outlined below.

**NOTE**

*If the G5 is installed as part of the G3X STC, the software for the G5 is included with the G3X software. Refer to the G3X STC for procedures to install the latest G5 software.*

**NOTE**

*If the G5 units report the same software P/N and versions as indicated on the Aviation Product/General Aviation/Indicators/G5 page, it is not required to complete this section.*

1. To obtain the latest software version approved for this STC, visit [www.Garmin.com](http://www.Garmin.com) and navigate to the Aviation Product/General Aviation/Indicators/G5 page. Do not download software from the Experimental Aircraft web page.



2. Download the self-extracting update file onto your hard drive.
3. Insert a FAT32-formatted micro SD card with at least 20 MB of free space into your card reader.
4. Open the self-extracting update file and follow the instructions provided by the installer application. You will be prompted to specify the drive letter of the SD card you wish to use for the update. When the transfer is complete, safely eject the SD card.

### 6.3.4 Initial Power On

1. Apply power to the G5 unit(s).
2. On the G5 attitude indicator, verify the attitude is displayed and there are no invalid parameters (no red-X shown).
3. On the G5 HSI/DG , verify heading information is displayed and there are no invalid parameters (no red-X shown).



#### NOTE

*On power-up, "Magnetometer not calibrated." may be displayed on the G5 #1 if a GMU 11 is installed. This will cause the compass card on the HSI/DG to display GPS track if installed as an HSI and nothing if installed as a DG. Magnetometer calibration is completed later in section 6.3.7.4.*

4. Continue to Section 6.3.5.

### 6.3.5 SOFTWARE LOADING PROCEDURE

G5 software loading can be performed in either normal or configuration mode.



#### NOTE

*If the G5 unit reports the same software P/N and version as indicated on the Aviation Product/General Aviation/Indicators/G5 page, it is not required to complete this section.*



#### NOTE

*If two G5's are installed, this procedure must be completed on both G5's and can be done concurrently. If both G5 units software do not match the G5 will post a "Software Version Mismatch" message on the display. This message will be removed when both units have been loaded with matching software.*

1. Power on the G5, then insert a properly formatted microSD™ card into the microSD™ card slot.



#### NOTE

*It is also acceptable to insert the microSD™ card before powering on the unit.*

2. A software update pop-up will appear on the screen. Select OK to begin the update.



#### NOTE

*The software update pop-up will only be displayed if the version of software to be loaded is newer than the version currently on the unit.*



3. The unit will reboot to the software update screen and the software update will begin automatically. This screen will show the progress of the software update.
4. Ensure power is not removed while the update is being performed.
5. The unit will reboot after the update is complete.
6. The new software version will be displayed while the unit powers on or in the configuration mode menu.

## 6.3.6 CONFIGURATION PAGES

### 6.3.6.1 Configuration Pages Summary

When in configuration mode the G5 displays the following configurations pages:

- Device Information – used to display LRU (device) specific information such as the software version and basic indicator configuration.
- Attitude – used to configure Indicator Type, Pitch Display preferences, and User Pitch offset.
- Air Data – used to enable/ disable the G5 Air Data Sensors and configure the Vertical Speed rate.
- Airspeed – allows for configuration of the reference speeds.
- Magnetometer – allows configuration of magnetometer and magnetometer positioning.
- Flight Controls – used to configure the system for Garmin and Non-Garmin autopilots if installed.
- Backlight – used to configure backlight configuration parameters.
- Display – used to configure the display format of the G5.
- Battery – used to set backup battery status and power off modes.
- GPS – used to configure the internal GPS receiver.
- Navigation – used to configure the display of navigation information.
- Units – This page is used to configure the units type to display altitude, airspeed, ground speed, vertical speed and pressure displays.
- RS-232 – used to configure the RS-232 input and output ports used of the G5.
- ARINC 429 - used to configure the ARINC 429 input and output ports used of the G5.
- Exit Configuration Mode – used to exit configuration mode.

### 6.3.6.2 G5 Configuration

Reference Section 5 to select the corresponding equipment configuration that is installed in the aircraft. The configuration settings are provided in the appropriate section for each installation possibility. See Section 6.4.1 for information about recording the configuration settings to keep in the aircraft records for future reference.

- G5 (Attitude Indicator) with a GPS Antenna – Section 5.3
- G5 (Attitude Indicator) with GPS Position Input (RS-232) – Section 5.4
- G5 (Attitude Indicator) and GMU 11 with GPS Position Input (RS-232) – Section 5.5
- G5 (Attitude Indicator or DG), GMU 11 and GPS Antenna – Section 5.6
- G5 (HSI) with VHF Navigator Section - 5.7
- G5 (HSI) with GPS/VHF Navigator Section - 5.8
- Dual G5 without Navigator Section - 5.9
- Dual G5 with VHF Navigator Section - 5.10
- Dual G5 with GPS/VHF Navigator Section - 5.11
- G5 (ADI) with GPS/VHF Navigator Section - 5.12

- G5 (ADI) with VHF Navigator Section - 5.13
- G5 (HSI) with GPS Navigator Section - 5.14
- Dual G5 with GPS Navigator Section - 5.15
- G5 (ADI) with GPS Navigator Section - 5.16
- G5 (HSI) with Two-inch GPS Navigator Section - 5.17
- Dual G5 with Two-Inch GPS Navigator Section - 5.18
- G5 (ADI) with Two-Inch GPS Navigator Section - 5.19
- G5 Portable Avionics Unit Interface Section - 5.20
- GAD 13 Interface Section - 5.21
- GAD 29B Interface to Garmin Autopilots Section - 5.23
- G5 Interface to Non-Garmin Autopilots Section - 5.24

### 6.3.7 G5 POST-INSTALLATION CALIBRATION PROCEDURES

After mechanical and electrical installation of the G5 has been completed, prior to operation, a set of post-installation calibration procedures must be carried out. Table 6-1 describes the required and optional calibration procedures.

**Table 6-1: Post-Installation Calibration Procedure Summary**

| Calibration Procedure | Procedure Name                       | Procedure Description                              | Installations Requiring Procedure                                                                                               |
|-----------------------|--------------------------------------|----------------------------------------------------|---------------------------------------------------------------------------------------------------------------------------------|
| A                     | Pitch/Roll Offset Compensation       | Level aircraft                                     | Procedure A is required for all installations                                                                                   |
| B                     | Engine Run-Up Vibration Test         | Validate vibration characteristics of installation | Procedure B is required for all installations                                                                                   |
| C                     | Air Data Static Pressure Calibration | Altitude Calibration                               | Procedure C is only required if Section 6.3.8.2 results for the G5 fall outside the tolerances of the Part 43 Appendix E tests. |
| D                     | GMU 11 Magnetometer Calibration      | Magnetometer Calibration                           | Procedure D is only required if a GMU 11 was installed                                                                          |

#### 6.3.7.1 CALIBRATION PROCEDURE A: PITCH/ROLL OFFSET COMPENSATION



**NOTE**

*The G5(s) must be installed within the tolerances shown in Figure 4-4 and Figure 4-5.*



**NOTE**

*If two G5's are installed, this procedure must be done on both and can be done concurrently.*



See Section 6.3.7.1.1 for example of this calibration procedure.

Using the following procedure, complete these equations.

$$\begin{array}{ccc} \text{New Pitch Offset} & \text{A/C Pitch Offset} & \text{Pitch Calibration} \\ \text{(From Step 9)} & \text{(From Step 2)} & \text{(For Step 10)} \\ \boxed{\phantom{000}} & - \boxed{\phantom{000}} & = \boxed{\phantom{000}} \end{array}$$
  
$$\begin{array}{ccc} \text{New Roll Offset} & \text{A/C Roll Offset} & \text{Roll Calibration} \\ \text{(From Step 9)} & \text{(From Step 2)} & \text{(For Step 10)} \\ \boxed{\phantom{000}} & - \boxed{\phantom{000}} & = \boxed{\phantom{000}} \end{array}$$

1. \*Consult the aircraft's maintenance manual and locate the longitudinal (ROLL) and lateral (PITCH) leveling points.
2. Using a digital level, document the Aircraft Roll and Pitch offsets from these leveling points as the aircraft sits on the landing gear. (Do not enter, exit, or move the aircraft at this point.) Use a negative number for left wing up or nose up readings. Use a positive number for left wing down or nose down readings.
3. Select the Attitude Configuration Page.
4. Select Calibrate Pitch/Roll.
5. Ensure that aircraft and the unit comply with all on-screen instructions then select Start.  
-Disregard item 1, leveling the aircraft is not necessary.
6. A progress screen will then be displayed. There is a 30 second countdown timer for the procedure that resets if the aircraft moves.
7. When the calibration is complete, a successful status message will be displayed along with the new pitch and roll offsets.
8. If the leveling offsets documented from Step 2 were both 0.0, the calibration is complete. If either new offset were other than 0.0, continue to step 9.
9. Document the "New Roll Offset" and "New Pitch Offset" numbers and complete the equation.
10. Press "Done" and adjust the values of the "Roll Calibration" and the "Pitch Calibration" values to the answers from the equations.



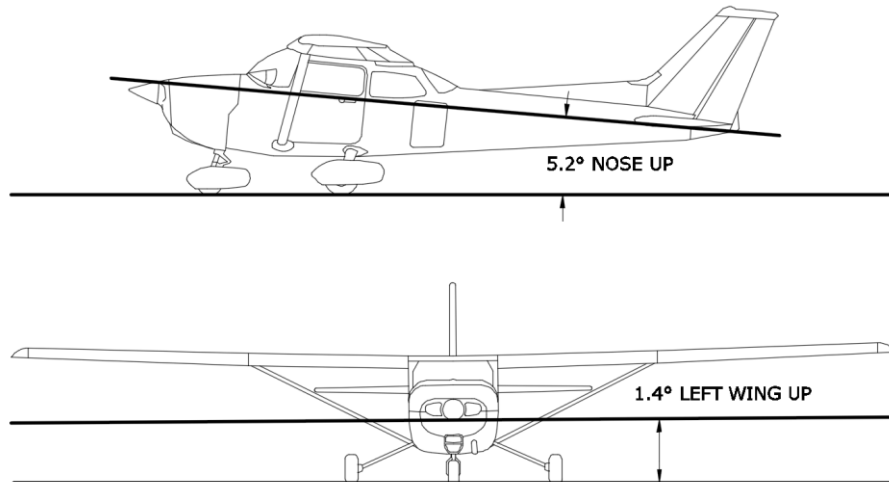
#### NOTE

It is recommended that the adjusted "Roll Calibration" and the "Pitch Calibration" values from step 10 be recorded in *Garmin G5 Electronic Flight Instrument Part 23 AML STC Maintenance Manual including Instructions for Continued Airworthiness*, P/N 190-01112-11, Appendix A and is retained with the aircraft permanent records.

11. Exit Configuration Mode.
12. This completes the Attitude Calibration Procedure.

## 6.3.7.1.1 Attitude Calibration Example

In the Figure 6-1, the aircraft is sitting 5.2° nose up and 1.4° left wing up, (both negative number). Also, the G5 is mounted in the pilot's panel, which has an 8° forward tilt. After completing the Calibration Procedure in Step 7, the value in the Pitch Calibration field on the G5 is 2.8° and -1.4° in the Roll Calibration field. See Figure 6-2 for the completed equations.



**Figure 6-1 Attitude Calibration Example**

|                                   |                                   |                                    |
|-----------------------------------|-----------------------------------|------------------------------------|
| New Pitch Offset<br>(From Step 9) | A/C Pitch Offset<br>(From Step 2) | Pitch Calibration<br>(For Step 10) |
| 2.8                               | -5.2                              | 8.0                                |
| New Roll Offset<br>(From Step 9)  | A/C Roll Offset<br>(From Step 2)  | Roll Calibration<br>(For Step 10)  |
| -1.4                              | -1.4                              | 0.0                                |

**Figure 6-2 Example of Calibration Equations**

*This area intentionally blank*

### 6.3.7.2 CALIBRATION PROCEDURE B: ENGINE RUN-UP VIBRATION TEST



**NOTE**

*Calibration Procedure B is required for all installations to validate the vibration characteristics of the installation.*



**NOTE**

*This section of the Calibration Procedure can be run in conjunction with the compass rose swing (Section 6.3.7.4.1).*



**NOTE**

*If two G5's are installed, this procedure must be done on both and can be done concurrently.*

Conduct the Engine Run-Up Vibration Test. The test is intended to help discover mounting issues and does not account for all possible vibration profiles that may be encountered during normal aircraft operation.

1. Select the Attitude configuration page.
2. Select Vibration Test.
3. Ensure the aircraft complies with all on-screen instructions, then select Start.
4. Gradually increase engine power from idle to full power and back to idle in 1-2 minutes. A screen will be displayed showing the test in progress.
5. After the gradual increase and decrease in aircraft power verify for passing or failing results.
  - a. If the green check mark remains during the engine power sequence, this indicates Passing results, select Done. This checkout is complete.
    - i. Exit configuration mode.
  - b. Failing results will be indicated by a red "X" as shown in Figure 6-3 below. Select Done when the test has been completed and follow the instructions in Step 6 below.

*This area intentionally blank*





**Figure 6-3 Engine Vibration Test Failure Indication**

6. If failures are indicated, repeat the test. If failures persist, the installation is unreliable until the source of the vibration problem is identified and remedied. Record the out of range limit values for future reference.

The following are potential causes for failures of the engine run-up test:

- a. Excessive flexing of the G5 mechanical mounting with respect to airframe
- b. Vibration or motion of the G5 caused by neighboring equipment and/or supports.
- c. Mounting of the G5 in a location that is subject to severe vibrations (e.g. close to an engine mount).
- d. Instrument panel shock mounts worn, broken, or permit excessive movement.
- e. Mounting screws and other hardware for G5 not firmly attached.
- f. G5 connector not firmly attached to unit.
- g. Cabling leading to the G5 not firmly secured to a supporting structure.
- h. An engine/propeller combination that is significantly out of balance.



**NOTE**

*In some aircraft, attempting the engine run-up test on a day with very strong and/or gusty winds may cause the test to occasionally fail. However, a failure during windy conditions cannot not be taken as evidence that the test would pass in calm conditions; an actual pass is required before the installation can be considered adequate.*

**6.3.7.3 CALIBRATION PROCEDURE C: AIR DATA STATIC PRESSURE CALIBRATION**



**NOTE**

**Procedure C is only required if Section 6.3.8.2 results for the G5 fall outside the tolerances of the Part 43 Appendix E tests.**



**NOTE**

*If two G5's are installed, this procedure must be done on both and can be done concurrently.*

The Air Data configuration page has a selection for static pressure calibration. This procedure is used to perform an altimeter calibration.



The static pressure calibration requires the use of a pressure control system (test set) with an altitude accuracy of at least  $\pm 5$  ft. at sea level and  $\pm 20$  ft. at 30,000 ft. It is necessary to re-calibrate to sea level (0 ft.), 10,000 ft., 20,000 ft., and optionally to 30,000 ft. The operator is allowed to finish the calibration at the end of the 20,000 ft. calibration if the aircraft operational ceiling is below 20,000 ft.



### CAUTION

*To avoid damaging the G5 pressure sensors, both the pitot and static ports must be connected to the test set.*

1. Prior to running the calibration procedure below perform a static system leak check in accordance with 14 CFR Part 43 Appendix E.
2. Select the Air Data configuration page.
3. Select Calibrate Static Pressure.
4. Ensure all on-screen instructions have been complied with, then press Start.
5. At each calibration point the display will present a screen indicating the pressure altitude to set. Once the altitude is set, select Ready to calibrate this pressure.
6. During the calibration at each pressure, the pressure must be held constant for 30 seconds for the calibration step to be successful. The calibration may be cancelled at any point should the test setup require adjustment before repeating. A progress screen will be displayed showing the status of the test.
7. Select Done when the static pressure calibration is successfully completed.
8. Exit configuration mode.

#### 6.3.7.4 CALIBRATION PROCEDURE D: GMU 11 Magnetometer Calibration



### NOTE

*All selections made in configuration mode in this section are made on the G5 ID strapped as #1. Refer to APPENDIX A for details on ID strapping.*



### CAUTION

*This magnetometer calibration procedure should be carried out on a compass rose to guarantee measurements free of environmental magnetic disturbances. If a compass rose is not available a sight compass can be used. Attempting to carry out this procedure on a typical ramp area may not yield a successful calibration. The accuracy of the heading display on the G5 cannot be guaranteed if this calibration is not performed on a magnetically clean and level surface.*

**NOTE**

*The calibration procedure in Section 6.3.7.1 must be completed prior to performing this procedure.*

**NOTE**

*A magnetometer calibration failure is indicated by a “Magnetometer not Calibrated” message on the G5 on power up. In the event of a failure, verify that the installation passes the magnetometer interference test in Section 6.3.8.3. If necessary, move the aircraft to a different location and attempt the magnetic calibration again.*

1. Start the aircraft engine in accordance with the aircraft AFM or POH.
2. After aircraft engine startup, taxi the aircraft to a properly calibrated compass rose.
3. At the compass rose, align the aircraft to a heading of magnetic north (+/- 10°).
4. Restart the G5 in configuration mode.
5. If the G5 installation being calibrated does not utilize a GPS input, go to the “GPS” page group and “Enable” the Internal GPS Receiver.
6. Go to the “Magnetometer” page Group on the G5 unit.
7. Select the “Calibrate Magnetometer...” page.
8. The G5 will display instructions. Follow the on-screen instructions and select “Next” to cycle through each page of instructions.
9. On the final page, select “Start” to begin the calibration.
10. The G5 display advises the operator when to turn the aircraft, when to stop, and when to turn again.
11. Upon instruction to turn, taxi the aircraft in a right turn. After approximately 25° to 30° of turn from the last heading, the G5 display advises the operator when to stop the aircraft.

**NOTE**

*If smooth accurate turns are not made, the G5 may incorrectly interpret a station and instruct to “Hold current position...” prior to or after completion of the heading change. If this scenario is encountered, it is best for the operator to temporarily ignore the “Hold current position...” command and instead use compass rose references to complete the heading change. Dwelling at these 30° increments for the time recommended by the G5 should result in successful calibration.*

12. The G5 instructs the operator to dwell at multiple headings around a complete circle.
13. Repeat the turn-and-stop process until the G5 advises that a successful calibration is complete and “Calibration: Success” is displayed on the G5.
14. Select “Done” on the G5 to conclude this procedure
15. If the Internal GPS receiver was “Enabled” above for G5 installations that do not utilize a GPS input “Disable” the Internal GPS receiver before exiting configuration mode.
16. Exit configuration mode.

### 6.3.7.4.1 Compass Swing

After the Magnetic Calibration Procedure is completed, a compass swing must be performed to verify the GMU 11 heading accuracy. If each heading displayed on the G5 (or G5 #1 and G5 #2) is within  $\pm 10^\circ$  of the actual heading no further adjustments are necessary.

1. With the G5 (or G5 #1 and G5 #2 for a dual G5 installation) in normal mode, all of the aircraft and avionics systems powered and operating normally, position the aircraft on a known compass rose at a heading  $360^\circ$  (North), or select a level and magnetically clean location and use a sight compass to position the aircraft to a heading of  $360^\circ$  (North).
2. Record the heading displayed on the G5 (or G5 #1 and G5 #2 for a dual G5 installation) in Table 6-2. Also record the heading displayed on the standby compass (these values can be used to complete the standby compass calibration card).
3. Repeat step 2 for each of the headings listed in Table 6-2.
4. Calculate the heading errors by subtracting the displayed (B) value from the actual (A) value for each of the headings in Table 6-2.

**Table 6-2: Heading Verification**

| Heading (A)         | Displayed G5 Heading (B) | Heading Error (A-B) | Stby Compass Heading |
|---------------------|--------------------------|---------------------|----------------------|
| $360^\circ$ (North) |                          |                     |                      |
| $30^\circ$          |                          |                     |                      |
| $60^\circ$          |                          |                     |                      |
| $90^\circ$ (East)   |                          |                     |                      |
| $120^\circ$         |                          |                     |                      |
| $150^\circ$         |                          |                     |                      |
| $180^\circ$ (South) |                          |                     |                      |
| $210^\circ$         |                          |                     |                      |
| $240^\circ$         |                          |                     |                      |
| $270^\circ$ (West)  |                          |                     |                      |
| $300^\circ$         |                          |                     |                      |
| $330^\circ$         |                          |                     |                      |

5. If all calculated heading errors for the G5 are  $\pm 10^\circ$  from the surveyed heading, the installation is acceptable and no further work is required to correct the GMU 11 installation. Proceed to Section 6.3.8.3.
6. If a Heading Error (A-B) is greater than  $\pm 10^\circ$ , calculate the average error by adding all errors and dividing by 12. This is the angle by which the GMU 11 must be physically rotated to correct the installation.
7. Modify the installation to rotate the GMU 11 by the amount calculated in the previous step. When looking down at the GMU 11, rotate clockwise for positive values, and counterclockwise for negative values.
8. After physically correcting the GMU 11 installation, repeat the procedures in Section 6.3.7.4 and this section.

### 6.3.8 G5 Post Installation Checks



**NOTE**

*If failures occur during post installation checks refer to Garmin P/N 190-01112-11, Garmin G5 Electronic Flight Instrument Part 23 AML STC Maintenance Manual Including ICA, Chapter 5 for troubleshooting assistance.*

### 6.3.8.1 Pitot Static System Leak Check

Perform a pitot static system leak check in accordance with the aircraft manufacturer's approved data.



#### CAUTION

*To avoid damaging the G5 pressure sensors, both the pitot and static ports must be connected to the air data test set.*

### 6.3.8.2 Altimeter System Check

For aircraft that are IFR certified, perform an altimeter system test of the G5 in accordance with 14 CFR Part 43 Appendix E.

- Do not perform paragraph (b)(1)(iv) Friction
- Do not perform paragraph (b)(1)(vi) Barometric Scale Error

### 6.3.8.3 Magnetometer Interference Check

With the G5 in configuration mode, initiate the magnetometer interference test procedure by performing the following steps:



#### NOTE

*All selections made in configuration mode in this section are made on the G5 ID strapped as #1. Refer to APPENDIX A for details on ID strapping.*

1. Select the "Magnetometer" page group on the G5 #1
2. Select the "Interference Test..." page.
3. Follow the instructions on each page displayed on the G5. Select "Next" to cycle through the pages and "Back" to go to the previous page.



#### NOTE

*The last page instructs the operator to prepare a detailed test sequence list with precise start and stop times for exercising all electronic devices. Only the electronic devices that are likely to affect the operation of the GMU 11 magnetometer need be included in the test sequence. The list of relevant electronic devices varies from aircraft to aircraft. This sequence is the same sequence developed for the magnetometer interference survey in APPENDIX C.*

4. Select "Start" to begin the test procedure.
5. The operator should carry out the actions called for in the prepared test sequence.



#### NOTE

*It is important that all actions are carried out in the order and at the precise elapsed time as specified in the prepared test sequence.*

6. After the "Begin test sequence" appears, wait approximately five seconds and perform each of the actions listed in the test sequence table. Refer to Section C.3 for an example of a test sequence.
7. When the test sequence is completed, wait approximately five seconds and then select "Done" to complete the test.

The G5 informs the operator if the installation has passed or failed the magnetometer interference test.



The results displayed indicate the worst case percentage of limit and the time at which it occurred. If the test passes, no further action is required.

If the test fails, the installation should be considered unreliable until the source of magnetic interference is identified and remedied. The magnetometer interference test must be repeated until passed. When the magnetometer interference test fails, record the magnetometer maximum deviation value and its corresponding timestamp. Compare the corresponding timestamp with the prepared test sequence to identify which action produced the problem.

Two common reasons for a failed magnetometer interference test are:

1. New equipment is installed in close proximity to the GMU 11 magnetometer.
2. An existing or new electronic device has become grounded through the aircraft structure instead of via the proper ground wire in a twisted shielded pair, especially if the ground return path through the aircraft structure passes near the GMU 11.

#### **6.3.8.4 Initial Power On Checks**

1. Apply power to the aircraft and aircraft systems and allow the aircraft systems to initialize.
2. On the G5 Attitude display, verify the following;
  - No red-X's displayed
  - Attitude display
  - Heading display (if interfaced to a GMU 11) Ground Track display (if not interfaced to a GMU 11)
  - Airspeed Tape (Digital read out will be dashes)
  - Altitude Tape (Digital readout should be reasonable to field elevation)
  - Ground speed field
  - Slip skid display
  - Current HDG/TRK bug
  - Barometric Pressure setting field
3. On the G5 HSI display, verify the following;
  - No red-X's displayed
  - Heading/ Ground Track display
    - Heading Display - if interfaced to a GMU 11, indicated by white numbers indicating magnetic heading.
    - Ground Track display (if not interfaced to a GMU 11, indicated by magenta numbers indicating GPS ground track.
  - Ground speed field (configurations without a GPS input will not display Ground Speed)
  - Current HDG/TRK bug
  - Rotating compass rose.

#### **6.3.8.5 GPS Position Check (Installations using a GPS Antenna Interfaced to the G5)**

This test must be conducted outside, as the use of a GPS repeater inside a hangar may result in a failed test.

1. Apply power to the aircraft and aircraft systems and allow the aircraft systems to initialize and the G5(s) to acquire sufficient satellites for a GPS solution.
2. Enter configuration mode on the G5 Attitude indicator and the G5 HSI if the optional GPS antenna is interfaced, and navigate to the GPS Configuration Page.
3. Ensure a valid GPS position fix is obtained by monitoring the GPS status. The following status indications are valid fixes for this test.



- 3D GPS
- 3D DIFFERENTIAL

#### **6.3.8.6 GPS Position Check (Installations using a GPS Navigator(s) Interfaced to the G5)**

This test must be conducted outside, as the use of a GPS repeater inside a hangar may result in a failed test. This test must be performed twice if the G5 is interfaced to two GPS navigators.

1. Apply power to the aircraft and aircraft systems and allow the aircraft systems to initialize and the GPS Navigator to acquire sufficient satellites for a GPS solution.
2. If installed with two GPS navigators, on a G5 select GPS1 as the navigation source.
3. On the G5 Attitude display, verify the following;
  - Ground Track display (if not interfaced to a GMU 11, indicated by magenta numbers indicating GPS ground track.)
  - Ground speed field
4. On the G5 HSI display, verify the following;
  - Ground Track display (if not interfaced to a GMU 11, indicated by magenta numbers indicating GPS ground track.)
  - Ground speed field
  - Current track bug
5. Repeat using GPS2 as the navigation source (if interfaced).

*This area intentionally blank*



### 6.3.8.7 VOR/LOC/GS Check

This test is only performed for installations that have an HSI installed and interfaced to a VHF navigation source(s). These tests must be performed twice if the G5 is interfaced to two VHF navigation sources.

Check the VOR, ILS, and Glideslope functions with ramp test equipment. Operate the equipment according to the test equipment manufacturer's instructions. Adjust the RF signal to a level adequate to perform the test. Select the appropriate HSI source as required by the VHF navigation source interfaced to the G5 HSI.



#### NOTE

*The HSI does not show a course deviation bar unless a valid VHF navigation frequency is tuned.*

#### 6.3.8.7.1 VOR

1. Apply power to the aircraft and aircraft systems and allow the aircraft systems to initialize.
2. Tune the VHF NAV to the NAV/COM Test Set frequency for VOR operation.
3. If installed with two VHF navigation sources, on the G5 HSI select VOR1, VLOC1, or LOC1 as the navigation source.
4. On the G5 HSI set the CDI course to 360 degrees.
5. On the NAV ramp tester simulate a centered VOR needle presentation.
6. Verify the G5 HSI CDI displays a centered deviation bar for VOR.
7. On the NAV ramp tester simulate 355 degrees.
8. Verify the G5 CDI deviation bar is one dot left.
9. On the NAV ramp tester simulate 350 degrees.
10. Verify the CDI deviation bar is two dots left.
11. On the NAV ramp tester simulate 340 degrees.
12. Verify the G5 HSI CDI deviation bar is full scale to the left.
13. On NAV ramp tester simulate 005 degrees.
14. Verify the G5 HSI CDI deviation bar is one dot right.
15. On the NAV ramp tester simulate 010 degrees.
16. Verify the G5 HSI CDI deviation bar is two dots right.
17. On the NAV ramp tester simulate 020 degrees.
18. Verify the G5 HSI CDI deviation bar is full scale to the right.
19. Repeat using VOR2, VLOC2, or LOC2 as the navigation source (if interfaced).





### 6.3.8.7.2 LOC/GS

1. Tune the VHF NAV to the NAV/COM Test Set frequency for LOC/GS operation.
2. On the NAV ramp tester simulate centered LOC and GS needles presentation.
3. If installed with two VHF navigation sources, on the G5 HSI select VOR1, VLOC1, or LOC1 as the navigation source.
4. Verify the G5 HSI CDI displays centered deviation for both LOC and GS.
5. On the NAV ramp tester simulate one dot left for LOC and one dot down for GS.
6. Verify G5 HSI CDI deviation bar is one dot left and the GS vertical deviation indicates one dot down.
7. On the NAV ramp tester simulate two dots left for LOC and two dots down for GS.
8. Verify G5 HSI CDI displays two dots left and the GS vertical deviation indicates two dots down.
9. On the NAV ramp tester simulate full scale left for LOC and full scale down for GS.
10. Verify G5 HSI CDI deviation bar is full scale left and the GS vertical deviation indicates full scale down.
11. On the NAV ramp tester simulate one dot right for LOC and one dot up for GS.
12. Verify G5 HSI CDI deviation bar is one dot right and the GS vertical deviation indicates one dot up.
13. On the NAV ramp tester simulate two dots right for LOC and two dots up for GS.
14. Verify G5 HSI CDI displays two dots right and the GS vertical deviation indicates two dots up.
15. On the NAV ramp tester simulate full scale right for LOC and full scale up for GS.
16. Verify G5 HSI CDI deviation bar is full scale right and the GS vertical deviation indicates full scale up.
17. Repeat using VOR2, VLOC2, or LOC2 as the navigation source (if interfaced).

### 6.3.8.8 GPS Navigation Interface Check

This test is only performed for installations that have an HSI installed and interfaced to a GPS navigation source. This test must be performed twice if the G5 is interfaced to two GPS navigators.

Conduct this test with the aircraft positioned where it can receive GPS signal.

1. Apply power to the aircraft and aircraft systems and allow the aircraft systems to initialize and the GPS navigator to acquire sufficient satellites for the GPS solution 3D Diff Nav.
2. If installed with two GPS navigators, on a G5 select GPS1 as the navigation source.
3. Enter a simple flight plan that contains a GPS LPV approach and activate the approach.
4. On the G5 Attitude indicator, verify the following:
  - a lateral deviation indicator is displayed directly above the slip skid indicator and a deviation pointer magenta in color.
  - A vertical deviation indicator to the right of the aircraft symbol.
5. On the G5 HSI verify the following:
  - A vertical deviation indicator to the right of the rotating compass rose.
  - GPS LPV displayed in magenta located in the top center of the rotating compass rose.
  - A lateral deviation indicator displayed in magenta.
  - A to/From indicator displayed in magenta.
  - A cyan bearing pointer. (Bearing Pointer may need to be activated on the HSI Menu)
6. Repeat using GPS2 as the navigation source (if interfaced).

### 6.3.8.9 GPS Receiver COM Interference Check

This test must be conducted outside, as the use of a GPS repeater inside a hangar may result in a failed test.

1. Apply power to the aircraft and aircraft systems and allow the aircraft systems to initialize and the G5(s) or GPS navigator (if installed) to acquire sufficient satellites for a GPS solution.



#### NOTE

*For G5's interfaced to a GPS navigator for position source access to the G5(s) configuration page is not necessary. Monitoring the G5 Attitude and/or G5 HSI for a loss of GPS information or amber LOI on the HSI is sufficient.*

For G5's interfaced to a GPS antenna:

2. Enter configuration mode on the G5 Attitude indicator and the G5 HSI if the optional GPS antenna is interfaced, and navigate to the GPS Configuration Page.
3. Ensure a valid GPS position fix is obtained by monitoring the GPS status. The following status indications are valid fixes for this test.
  - 3D GPS
  - 3D DIFFERENTIAL
4. Select 121.150 MHz on the COM transceiver.
5. Transmit for a period of 30 seconds while monitoring the GPS status.
6. During the transmit period,
  - On G5(s) with a direct GPS antenna connected, verify that the GPS status does not lose a valid GPS position fix.
  - On G5(s) interfaced to a GPS navigator for position source monitor the G5 Attitude indicator and/or G5 HSI for a loss of GPS information (ground speed information) or amber LOI on the HSI.
7. Repeat steps 2 through 4 for the following frequencies:
  - 121.175 MHz
  - 121.200 MHz
  - 131.250 MHz
  - 131.275 MHz
  - 131.300 MHz
8. Repeat steps 2 through 5 for all other installed COM transceivers (if applicable).
9. If an installed COM supports 8.33 MHz channel spacing, increase the transmit period to 35 seconds and repeat steps 3 through 5 for the following frequencies:
  - 121.185 MHz
  - 121.190 MHz
  - 130.285 MHz
  - 131.290 MHz
10. Repeat step 7 for all other installed COM transceivers supporting 8.33 MHz channel spacing (if applicable).

### 6.3.9 OAT Test (GAD 13)

This test is required when a GAD 13 has been installed with the G5, perform only applicable steps to the G5 installation.

1. Apply power to the aircraft and aircraft systems and allow the aircraft systems to initialize.
2. Once G5(s) have initialized, verify on the ADI (if installed):
  - a. OAT information on ADI is valid and within  $\pm 1.5^{\circ}\text{C}$  ( $\pm 2.7^{\circ}\text{F}$ ) of ambient air temperature.
  - b. DENSITY ALT is displayed in the lower right corner.
  - c. TAS is correct given the current aircraft configuration.

**Note:** TAS will display as "--" if aircraft is stationary.



Figure 6-4 ADI display of OAT and TAS (typical values shown)

*This area intentionally blank*

3. Once G5(s) have initialized on the HSI (if installed):
  - a. Remove power from the G5 ADI (if installed).
 

**Note:** Manual reversion to HSI format may be required.
  - b. Verify crosswind information box is displayed on the HSI.
 

**Note:** If crosswinds display as NO WIND DATA this is acceptable.
  - c. If only a G5 HSI is installed, verify the OAT is shown and valid in the bottom left hand corner of the G5 HSI.



Figure 6-5 HSI Display of Crosswind (Typical Values Shown)

### 6.3.10 Electromagnetic Compatibility (EMC) Check

An EMC check must be conducted once the G5(s) and supporting equipment is installed and all interfaces to external equipment are verified to be correctly working. The EMC check makes sure the equipment is not producing unacceptable interference to the other avionics systems, and other avionics systems are not producing unacceptable interference to the G5.

An example EMC Source/Victim matrix is shown in Figure 6-6.

1. Enter equipment installed in the aircraft into the Source row and Victim column of the fillable form.
2. Apply power to all avionics systems except the equipment installed under this STC.
3. Make sure all existing avionics systems are properly functioning.
4. Apply power to the G5.
5. Remove power from all other avionics systems.
6. Apply power and/or operate the systems listed on the fillable form, one system at a time. Make sure to pull/push circuit breakers or turn on/off large loads, e.g. heaters, cycling flaps (if electrical) etc.
7. Make sure the G5 properly functions.
  - a. When the VHF COM is operating as a source, transmit on low/med/high unused frequencies.
8. Make sure each radio properly functions.
  - a. For each VHF COM radio, monitor one local frequency, one remote (far field) frequency, and one unused frequency.
  - b. Make sure there are no unintended squelch breaks or audio tones interfere with communications.



- c. For each VHF NAV radio, monitor one local frequency, one remote (far field) frequency, and one unused frequency.
  - d. Make sure there are no guidance errors.
  - e. Make sure there are no audio tones that interfere with the station ID.
  - f. For each GPS Navigator, enter a simple flight plan and display as appropriate. i.e. Navigator Display, G5, HSI, CDI etc., if installed.
  - g. Make sure there are no guidance errors.
9. Make sure all other avionics properly function.

|                      |                           | VICTIM |                      |                       |                               |                       |                  |       |               |                         |                 |                     |                        |                |            |            |             |           |        |              |         |                     |             |            |                 |          |             |             |         |               |                      |  |
|----------------------|---------------------------|--------|----------------------|-----------------------|-------------------------------|-----------------------|------------------|-------|---------------|-------------------------|-----------------|---------------------|------------------------|----------------|------------|------------|-------------|-----------|--------|--------------|---------|---------------------|-------------|------------|-----------------|----------|-------------|-------------|---------|---------------|----------------------|--|
|                      |                           | G5 #1  | G5 #2 (If installed) | GMU 11 (If installed) | GAD 29/29B/29D (If installed) | GAD 13 (if installed) | Magnetic Compass | Clock | OAT Indicator | Power Plant Instruments | Autopilot / SAS | Navigation Radio(s) | Communication Radio(s) | Engine Relight | Fuel Valve | Pitot Heat | Pulse Light | Generator | Pos Lt | Anti Coll Lt | Ldg Lts | Gov RPM Incr / Decr | Eng Deicing | Hyd System | Radar Altimeter | TAS/TCAS | Transponder | Audio Panel | GTX 3X5 | DME equipment | <add equipment here> |  |
| SOURCE               | G5 #1                     |        |                      |                       |                               |                       |                  |       |               |                         |                 |                     |                        |                |            |            |             |           |        |              |         |                     |             |            |                 |          |             |             |         |               |                      |  |
|                      | G5 #2 (If installed)      |        |                      |                       |                               |                       |                  |       |               |                         |                 |                     |                        |                |            |            |             |           |        |              |         |                     |             |            |                 |          |             |             |         |               |                      |  |
|                      | GMU 11 (If installed)     |        |                      |                       |                               |                       |                  |       |               |                         |                 |                     |                        |                |            |            |             |           |        |              |         |                     |             |            |                 |          |             |             |         |               |                      |  |
|                      | GAD 29/29B (If installed) |        |                      |                       |                               |                       |                  |       |               |                         |                 |                     |                        |                |            |            |             |           |        |              |         |                     |             |            |                 |          |             |             |         |               |                      |  |
|                      | GAD 13 (if installed)     |        |                      |                       |                               |                       |                  |       |               |                         |                 |                     |                        |                |            |            |             |           |        |              |         |                     |             |            |                 |          |             |             |         |               |                      |  |
|                      | Magnetic Compass          |        |                      |                       |                               |                       |                  |       |               |                         |                 |                     |                        |                |            |            |             |           |        |              |         |                     |             |            |                 |          |             |             |         |               |                      |  |
|                      | Clock                     |        |                      |                       |                               |                       |                  |       |               |                         |                 |                     |                        |                |            |            |             |           |        |              |         |                     |             |            |                 |          |             |             |         |               |                      |  |
|                      | OAT Indicator             |        |                      |                       |                               |                       |                  |       |               |                         |                 |                     |                        |                |            |            |             |           |        |              |         |                     |             |            |                 |          |             |             |         |               |                      |  |
|                      | Power Plant Instruments   |        |                      |                       |                               |                       |                  |       |               |                         |                 |                     |                        |                |            |            |             |           |        |              |         |                     |             |            |                 |          |             |             |         |               |                      |  |
|                      | Autopilot / SAS           |        |                      |                       |                               |                       |                  |       |               |                         |                 |                     |                        |                |            |            |             |           |        |              |         |                     |             |            |                 |          |             |             |         |               |                      |  |
|                      | Navigation Radio(s)       |        |                      |                       |                               |                       |                  |       |               |                         |                 |                     |                        |                |            |            |             |           |        |              |         |                     |             |            |                 |          |             |             |         |               |                      |  |
|                      | Communication Radio(s)    |        |                      |                       |                               |                       |                  |       |               |                         |                 |                     |                        |                |            |            |             |           |        |              |         |                     |             |            |                 |          |             |             |         |               |                      |  |
|                      | Engine Relight            |        |                      |                       |                               |                       |                  |       |               |                         |                 |                     |                        |                |            |            |             |           |        |              |         |                     |             |            |                 |          |             |             |         |               |                      |  |
|                      | Fuel Valve                |        |                      |                       |                               |                       |                  |       |               |                         |                 |                     |                        |                |            |            |             |           |        |              |         |                     |             |            |                 |          |             |             |         |               |                      |  |
|                      | Pitot Heat                |        |                      |                       |                               |                       |                  |       |               |                         |                 |                     |                        |                |            |            |             |           |        |              |         |                     |             |            |                 |          |             |             |         |               |                      |  |
|                      | Pulse Light               |        |                      |                       |                               |                       |                  |       |               |                         |                 |                     |                        |                |            |            |             |           |        |              |         |                     |             |            |                 |          |             |             |         |               |                      |  |
|                      | Generator                 |        |                      |                       |                               |                       |                  |       |               |                         |                 |                     |                        |                |            |            |             |           |        |              |         |                     |             |            |                 |          |             |             |         |               |                      |  |
|                      | Pos Lt                    |        |                      |                       |                               |                       |                  |       |               |                         |                 |                     |                        |                |            |            |             |           |        |              |         |                     |             |            |                 |          |             |             |         |               |                      |  |
|                      | Anti Coll Lt              |        |                      |                       |                               |                       |                  |       |               |                         |                 |                     |                        |                |            |            |             |           |        |              |         |                     |             |            |                 |          |             |             |         |               |                      |  |
|                      | Ldg Lts                   |        |                      |                       |                               |                       |                  |       |               |                         |                 |                     |                        |                |            |            |             |           |        |              |         |                     |             |            |                 |          |             |             |         |               |                      |  |
|                      | Gov RPM Incr / Decr       |        |                      |                       |                               |                       |                  |       |               |                         |                 |                     |                        |                |            |            |             |           |        |              |         |                     |             |            |                 |          |             |             |         |               |                      |  |
|                      | Eng Deicing               |        |                      |                       |                               |                       |                  |       |               |                         |                 |                     |                        |                |            |            |             |           |        |              |         |                     |             |            |                 |          |             |             |         |               |                      |  |
|                      | Hyd System                |        |                      |                       |                               |                       |                  |       |               |                         |                 |                     |                        |                |            |            |             |           |        |              |         |                     |             |            |                 |          |             |             |         |               |                      |  |
| Radar Altimeter      |                           |        |                      |                       |                               |                       |                  |       |               |                         |                 |                     |                        |                |            |            |             |           |        |              |         |                     |             |            |                 |          |             |             |         |               |                      |  |
| TAS/TCAS             |                           |        |                      |                       |                               |                       |                  |       |               |                         |                 |                     |                        |                |            |            |             |           |        |              |         |                     |             |            |                 |          |             |             |         |               |                      |  |
| Transponder          |                           |        |                      |                       |                               |                       |                  |       |               |                         |                 |                     |                        |                |            |            |             |           |        |              |         |                     |             |            |                 |          |             |             |         |               |                      |  |
| Audio Panel          |                           |        |                      |                       |                               |                       |                  |       |               |                         |                 |                     |                        |                |            |            |             |           |        |              |         |                     |             |            |                 |          |             |             |         |               |                      |  |
| GTX 3X5              |                           |        |                      |                       |                               |                       |                  |       |               |                         |                 |                     |                        |                |            |            |             |           |        |              |         |                     |             |            |                 |          |             |             |         |               |                      |  |
| DME Eqmt             |                           |        |                      |                       |                               |                       |                  |       |               |                         |                 |                     |                        |                |            |            |             |           |        |              |         |                     |             |            |                 |          |             |             |         |               |                      |  |
| <add equipment here> |                           |        |                      |                       |                               |                       |                  |       |               |                         |                 |                     |                        |                |            |            |             |           |        |              |         |                     |             |            |                 |          |             |             |         |               |                      |  |

Figure 6-6 Example EMC Source/Victim Matrix



### 6.3.11 Vacuum System Pressure Setting

If a vacuum instrument was removed by the installation of the G5 Electronic Flight Instrument and there are other instruments using the vacuum system, follow the aircraft manufacturers procedure to set instrument vacuum system pressure.

### 6.3.12 Non-Garmin Autopilot Interface Tests

The G5 system can interface with various autopilots. Before proceeding with the autopilot interface tests, verify that the G5 has been configured for the installed autopilot, if applicable, as defined in Section 5.24. Only those interfaces which are directly affected by the G5 AML STC are covered by this manual; if any other autopilot modifications were performed they are outside the scope of this STC and must be checked in accordance with the autopilot installation manual.



#### **WARNING**

*It is important that the G5 system be properly configured in order to prevent signals from the G5 system from damaging the autopilot computer. Refer to section 5.24.*



#### **NOTE**

*The following procedures are general in nature and it may be necessary to reference the autopilot manufacturers testing instructions to allow the autopilot to be tested properly.*

#### 6.3.12.1 Heading and Course Error Tests

##### 6.3.12.1.1 Heading

1. Apply power to the aircraft and aircraft systems and allow the aircraft systems to initialize.
2. On the G5 HSI, set the heading bug to the current aircraft heading.
3. Engage the autopilot in heading mode.
4. Adjust the heading bug to the left of the aircraft heading.
5. Verify that the flight controls move toward the left.
6. On the G5 HSI, adjust the heading bug to the right of the aircraft heading.
7. Verify the flight controls move toward the right.
8. Center the heading bug at the aircraft heading.
9. Disengage the autopilot.

*This area intentionally blank*



### 6.3.12.1.2 VOR Course

1. Apply power to the aircraft and aircraft systems and allow the aircraft systems to initialize.
2. Tune the VHF NAV to the NAV/COM Test Set frequency for VOR operation.
3. Set the Course pointer on the G5 HSI 15 degrees to the left of aircraft heading and ensure that the G5 HSI CDI is displaying VOR navigation information.
4. Simulate a VOR signal with a “TO” course equal to the aircraft heading.
5. Slowly adjust the course pointer on the G5 HSI CDI toward the aircraft heading until VOR captures.
6. Center G5 HSI CDI course pointer on the aircraft heading.
7. Engage the autopilot in NAV mode.
8. Adjust the NAV ramp tester course and the G5 HSI CDI course pointer 20 degrees to the left of current aircraft heading.
9. Verify that the flight controls move toward the left.
10. Adjust NAV ramp tester course to aircraft heading.
11. Adjust the NAV ramp tester course and the G5 HSI CDI course pointer 20 degrees to the right of current aircraft heading.
12. Verify that the flight controls move toward the right.
13. Adjust the NAV ramp tester course to aircraft heading.
14. Disengage the autopilot.

### 6.3.12.1.3 LOC

1. Tune the VHF NAV to the NAV/COM Test Set frequency for LOC operation.
2. On the NAV ramp tester simulate centered LOC needle presentation.
3. Set the Course pointer on the G5 HSI to the current aircraft heading.
4. Verify the G5 HSI CDI displays centered deviation for LOC.
5. On the NAV ramp tester simulate 0.093 DDM Left LOC.
6. Verify G5 HSI CDI deviation bar is one dot left.
7. Verify that the flight controls turn to the left.
8. On the NAV ramp tester simulate 0.093 DDM Right LOC.
9. Verify G5 HSI CDI displays one dot right.
10. Verify that the flight controls turn to the right.
11. On the NAV ramp tester simulate centered LOC needle presentation.
12. Disengage the autopilot.

### 6.3.12.1.4 GPSS Course

This test is only performed for installations that are interfaced to a GPS navigation source and the interfaced autopilot did not previously have a GPSS function. Conduct this test with the aircraft positioned where it can receive GPS signal.

1. On the GPS navigator, enter a simple Direct-To flight plan with a waypoint that is on the current aircraft heading and select the G5 HSI CDI to display GPS. If the navigator has the capability to enter user waypoints, a user waypoint can be entered to facilitate this test. It is suggested that the waypoint be within 5 miles of the current aircraft position for best results.
2. On the G5 Attitude display, press the multifunction knob to display the G5 attitude menu, highlight GPSS and press the multifunction knob to select GPSS.
3. Verify the following;  
On the G5 Attitude (if Installed)



- GPSS field in the menu has a green bar at the bottom indicating GPSS is selected.
- The heading bug is a hollow cyan bug.
- An advisory display is presented in the upper left hand corner that shows a normal heading bug crossed by a white X and GPSS in white next to the bug.

On the G5 HSI

- GPSS field in the menu has a green bar at the bottom indicating GPSS is selected.
  - The heading bug is a hollow cyan bug.
  - An advisory display is presented in the upper left hand corner that shows a normal heading bug crossed by a white X and GPSS in white next to the bug.
4. On the navigator select OBS to enter GPS OBS mode.
  5. Set the OBS course for the current aircraft heading. (it is assumed the waypoint is on the current aircraft heading)
  6. Engage the autopilot in HDG mode.
  7. Adjust the OBS course 20 degrees to the left of current aircraft heading.
  8. Verify that the flight controls move toward the left.
  9. Adjust the OBS course 20 degrees to the right of current aircraft heading.
  10. Verify that the flight controls move toward the right.
  11. Adjust the OBS course to aircraft heading.
  12. Disengage the autopilot.

## 6.4 Documentation Checks

### 6.4.1 Instructions for Continued Airworthiness (ICA)

Ensure the appropriate aircraft information is recorded in *Garmin G5 Electronic Flight Instrument Part 23 AML STC Maintenance Manual including Instructions for Continued Airworthiness*, P/N 190-01112-11, Appendix A, Appendix B and Appendix C and is retained with the aircraft permanent records.

Insert the completed Appendices of the STC MM/ICA into the aircraft permanent records.

### 6.4.2 Weight and Balance

Addition of the G5(s) and supporting equipment must allow the empty weight center of gravity (CG) to fall within the aircraft's acceptable range (refer to the aircraft's POH or AFM). Perform a weight and balance computation and update the aircraft records.





### 6.4.3 AFMS Autopilot Information Record

Ensure that the Airplane Flight Manual Supplement (AFMS) 190-01112-13 is completed and inserted in the AFM or POH.

1. Fill in the required airplane information on the AFMS cover sheet.
2. In AFMS Section 4.4 (Autopilot Operations with the G5 HSI), fill in all applicable checkboxes corresponding to the interfaces to the autopilot. More than one box may be checked, depending upon the installation.

The G5 Electronic Flight Instrument installation in this aircraft provides the following autopilot functions (check the appropriate boxes):

- This installation does not interface with the autopilot (basic wing leveling autopilot or no autopilot is installed in the aircraft).
- A GAD 29B is installed in this aircraft.
  - Course / NAV Selection coupling to the autopilot.
  - Heading Bug coupling capability to the autopilot.
  - Roll Steering (GPSS) emulated via heading mode.

OR

- Roll Steering capable autopilot (GPSS menu function for emulation not applicable).
  - GAD 13 is installed in this aircraft.
    - OAT is available for navigation use
3. Insert the completed AFMS into the AFM or POH.

*This area intentionally blank*

## APPENDIX A - CONNECTOR INFORMATION

### A.1 G5

#### A.1.1 J51

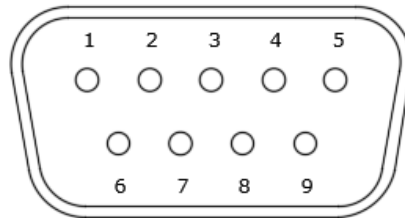


Figure 6-7 J51 on the G5

#### J51 Pin Descriptions

| Pin | Pin Name         | I/O |
|-----|------------------|-----|
| 1   | CAN-H            | I/O |
| 2   | CAN-L            | I/O |
| 3   | UNIT ID          | In  |
| 4   | RS-232 RX 1      | In  |
| 5   | RS-232 TX 1      | Out |
| 6   | SIGNAL GROUND    | --  |
| 7   | AIRCRAFT POWER 1 | In  |
| 8   | AIRCRAFT POWER 2 | In  |
| 9   | POWER GROUND     | --  |

#### A.1.2 Aircraft Power

The G5 operates using power from one 14 / 28 VDC input. Pin 8 (AIRCRAFT POWER 2) is not used as a part of this STC.



#### NOTE

*AIRCRAFT POWER 2 is for connecting to an alternate power source, such as on aircraft with two electrical buses.*

#### A.1.3 RS-232

The G5 has one RS-232 channel that may be used to interface to an existing GPS navigator or GPS source to receive GPS data for attitude aiding. Also, the G5 RS-232 port can be used to receive VHF and GPS navigation information.

For specific configuration settings for RS-232 refer to Section 6.3.6.2.

If an existing connection is made to the RS-232 port, the G5 connection can be spliced into the existing wiring at the connector. For specific wiring information, refer to Section 5.

### A.1.4 CAN

The G5 CAN bus conforms to the BOSCH standard for Controller Area Network (CAN) 2.0-B and ISO 11989. See Section 3.4.5.2 for details. The G5 can utilize CAN bus connections when specified by a specific equipment configuration to allow heading information from the GMU 11, communication of navigation data from the GAD 29/29B/29D, communication between the G5 Attitude or Turn Coordinator and the G5 HSI, and communication from the GAD 13 for Outside Air Temperature (OAT) information.

For specific wiring information, refer to Section 5.

### A.1.5 Unit ID

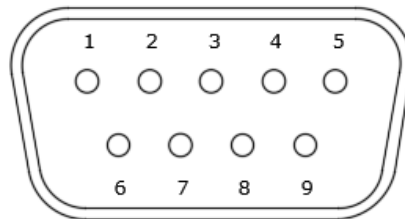
The G5 detects its assigned unit type at startup by checking the UNIT ID pin. This pin can be strapped into the following configurations. A maximum of two G5 units may be used in a single installation.

**Unit ID Configurations**

| Unit ID | Comment             |
|---------|---------------------|
| G5 #1   | Pin 3 No Connection |
| G5 #2   | Ground pin 3        |

## A.2 GMU 11

### A.2.1 J111



**Figure 6-8 J111 on the GMU 11**

**J111 Pin Descriptions**

| Pin | Pin Name         | I/O |
|-----|------------------|-----|
| 1   | CAN-H            | I/O |
| 2   | CAN-L            | I/O |
| 3   | UNIT ID          | In  |
| 4   | RS-232 RX 1      | In  |
| 5   | RS-232 TX 1      | Out |
| 6   | SIGNAL GROUND    | --  |
| 7   | AIRCRAFT POWER 1 | In  |
| 8   | AIRCRAFT POWER 2 | In  |
| 9   | POWER GROUND     | --  |



### A.2.2 Aircraft Power

The GMU 11 operates using power from one 14 / 28 VDC input. Pin 8 (AIRCRAFT POWER 2) is not used as a part of this STC.



#### NOTE

*AIRCRAFT POWER 2 is for connecting to an alternate power source, such as on aircraft with two electrical buses.*

### A.2.3 RS-232

RS-232 is not used or approved for use by this STC.

### A.2.4 CAN Bus

The GMU 11 CAN bus conforms to the BOSCH standard for Controller Area Network (CAN) 2.0-B and ISO 11898. See Section 3.4.5.2 for details. The CAN bus connection on the GMU 11 is used to connect the GMU 11 to one or two G5s, a GAD 29/29B/29D, and a GAD 13.

For specific wiring information, refer to Section 5.

### A.2.5 Unit ID

The GMU 11 detects its assigned unit type at startup by checking the UNIT ID pin. Only one GMU 11 may be installed by this STC. Ensure pin 3 is not connected to allow the GMU 11 to properly detect its assigned unit type.

**Unit ID Configurations**

| <b>Unit ID</b>       | <b>Comment</b>          |
|----------------------|-------------------------|
| GMU 11 #1            | Pin 3 No Connection     |
| GMU 11 #2 (Not Used) | Ground pin 3 (Not Used) |

*This area intentionally blank*

### A.3 GAD 29/29B/29D

#### A.3.1 J291

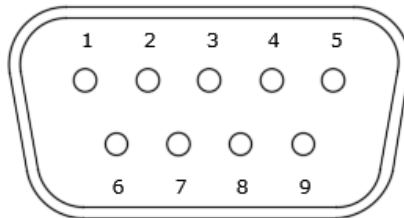


Figure 6-9 J291 on the GAD 29/29B/29D

J291 Pin Descriptions

| Pin | Pin Name         | I/O |
|-----|------------------|-----|
| 1   | CAN-H            | I/O |
| 2   | CAN-L            | I/O |
| 3   | RESERVED         | --  |
| 4   | RESERVED         | --  |
| 5   | RESERVED         | --  |
| 6   | GROUND           | --  |
| 7   | AIRCRAFT POWER 1 | In  |
| 8   | AIRCRAFT POWER 2 | In  |
| 9   | GROUND           | --  |

#### A.3.2 J292

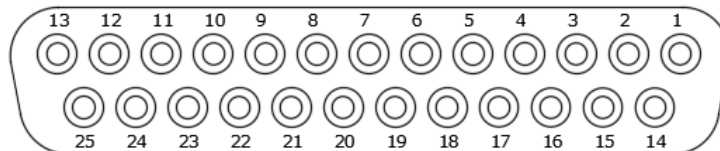


Figure 6-10 J292 on the GAD 29/29B/29D

J292 Pin Descriptions

| Pin | Pin Name                           | I/O |
|-----|------------------------------------|-----|
| 1   | AC REFERENCE HI<br>(GAD 29B ONLY)  | In  |
| 2   | AC REFERENCE LO<br>(GAD 29B ONLY)  | In  |
| 3   | HDG/CRS VALID<br>(GAD 29B ONLY)    | Out |
| 4   | ARINC 429 RX 4B                    | In  |
| 5   | ARINC 429 RX 3B                    | In  |
| 6   | ARINC 429 TX 2B                    | Out |
| 7   | ARINC 429 TX 2B                    | Out |
| 8   | HEADING ERROR HI<br>(GAD 29B ONLY) | Out |

|    |                                    |     |
|----|------------------------------------|-----|
| 9  | CAN TERM 1                         | --  |
| 10 | ARINC 429 RX 2B                    | In  |
| 11 | ARINC 429 RX 1B                    | In  |
| 12 | ARINC 429 TX 1B                    | Out |
| 13 | ARINC 429 TX 1B                    | Out |
| 14 | HEADING ERROR LO<br>(GAD 29B ONLY) | In  |
| 15 | COURSE ERROR HI<br>(GAD 29B ONLY)  | Out |
| 16 | ARINC 429 RX 4A                    | In  |
| 17 | ARINC 429 RX 3A                    | In  |
| 18 | ARINC 429 TX 2A                    | Out |
| 19 | ARINC 429 TX 2A                    | Out |
| 20 | COURSE ERROR LO<br>(GAD 29B ONLY)  | In  |
| 21 | CAN TERM 2                         | --  |
| 22 | ARINC 429 RX 2A                    | In  |
| 23 | ARINC 429 RX 1A                    | In  |
| 24 | ARINC 429 TX 1A                    | Out |
| 25 | ARINC 429 TX 1A                    | Out |

### A.3.3 Aircraft Power

The GAD 29/29B/29D operates using power from one 14 / 28 VDC input. Pin 8 (AIRCRAFT POWER 2) is not used as a part of this STC.



#### NOTE

*AIRCRAFT POWER 2 is for connecting to an alternate power source, such as on aircraft with two electrical buses.*

### A.3.4 CAN Bus

The GAD 29/29B/29D CAN bus conforms to the BOSCH standard for Controller Area Network (CAN) 2.0-B and ISO 11898. See Section 3.4.5.2 for details. The CAN bus connection on the GAD 29/29B/29D is used to connect the GAD 29/29B/29D to one or two G5s, a GMU 11, and a GAD 13.

For specific wiring information, refer to Section 5.

### A.3.5 ARINC 429

The ARINC 429 outputs conform to ARINC 429 electrical specifications when loaded with up to 5 standard ARINC 429 receivers. The G5 in conjunction with the GAD 29/29B/29D can receive GPS and VHF navigation data and send selected course when connected to a GPS or GPS/VHF navigator.

For specific wiring information, refer to Section 5

### A.3.6 Autopilot Heading/Course (GAD 29B/29D Only)

The GAD 29B/29D can provide analog heading and course error outputs to third-party analog autopilots. In the case of an AC autopilot, the GAD 29B/29D has an AC REFERENCE signal input.

For specific wiring information, refer to Section 5.

## A.4 GAD 13

### A.4.1 J131

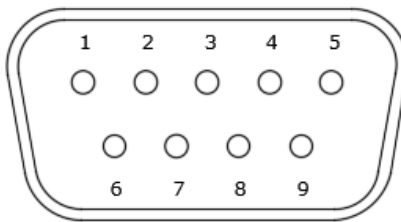


Figure 6-11 J131 on the GAD 13

J131 Pin Descriptions

| Pin | Pin Name                    | I/O |
|-----|-----------------------------|-----|
| 1   | CAN-H                       | I/O |
| 2   | CAN-L                       | I/O |
| 3   | TEMP PROBE IN HI            | In  |
| 4   | ACTIVE TEMP PROBE IN        | In  |
| 5   | ACTIVE TEMP PROBE POWER OUT | Out |
| 6   | TEMP PROBE IN LO            | In  |
| 7   | AIRCRAFT POWER              | In  |
| 8   | TEMP PROBE POWER OUT        | Out |
| 9   | GROUND                      | --  |

#### A.4.2 Aircraft Power

The GAD 13 operates using power from one 14 / 28 VDC input.

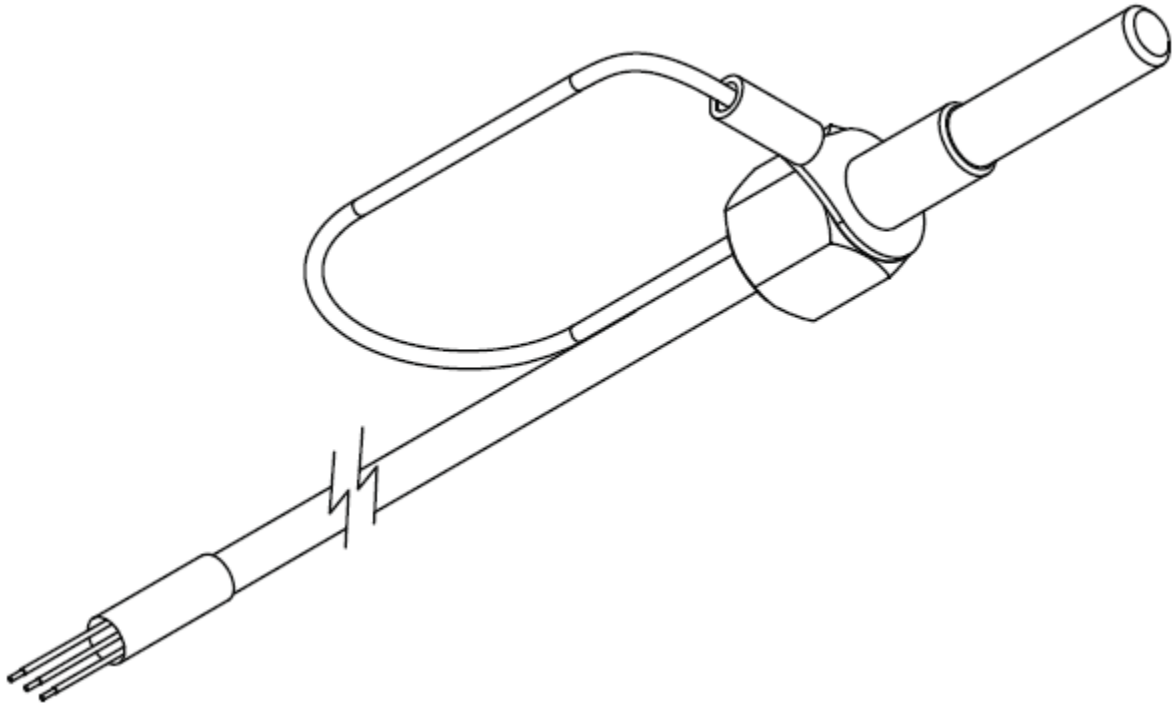
#### A.4.3 CAN Bus

The GAD 13 CAN bus conforms to the BOSCH standard for Controller Area Network (CAN) 2.0-B and ISO 11898. See Section 3.4.5.2 for details. The CAN bus connection on the GAD 13 is used to connect the GAD 13 to one or two G5s, a GMU 11, and a GAD 29/29B/29D.

For specific wiring information, refer to Section 5.

#### A.4.4 OAT Probe Interface

The GAD 13 has three pins for interface to a passive (RTD type) and two pins for interface to an active OAT probe. This interface provides excitation voltage/current, and temperature sensing capabilities for a OAT probe. For specific wiring information, refer to Section 5.



**Figure 6-12 GTP 59**

| PIN | WIRE                | I/O |
|-----|---------------------|-----|
| WH  | TEMP PROBE POWER IN | IN  |
| BL  | TEMP PROBE OUT HI   | OUT |
| OR  | TEMP PROBE OUT LO   | OUT |

### A.5.1 OAT Sensing

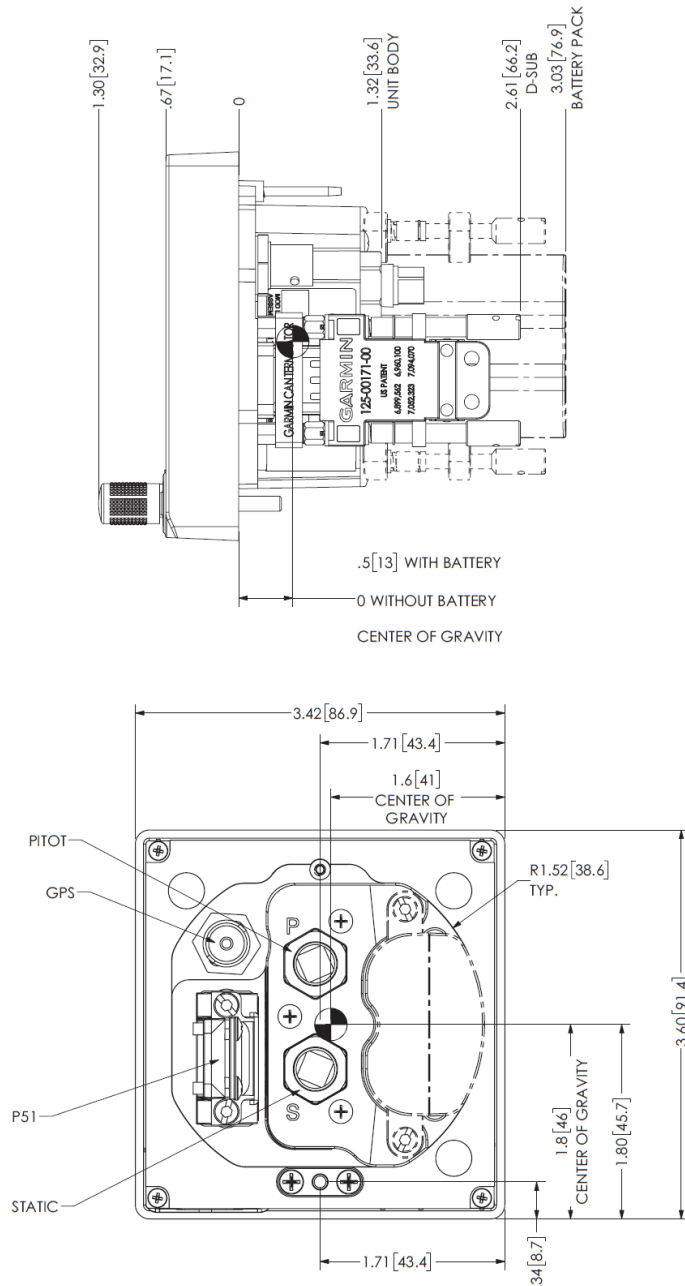
The GTP 59 is an OAT sensing device. The connection to this LRU is made via pre-installed lead wires, if they are not long enough to reach the GAD 13, crimp splices can be used to extend the lead wire to the GAD 13. The pre-installed lead wires are ten feet in length. For specific wiring information, refer to Section 5.

*This area intentionally blank*



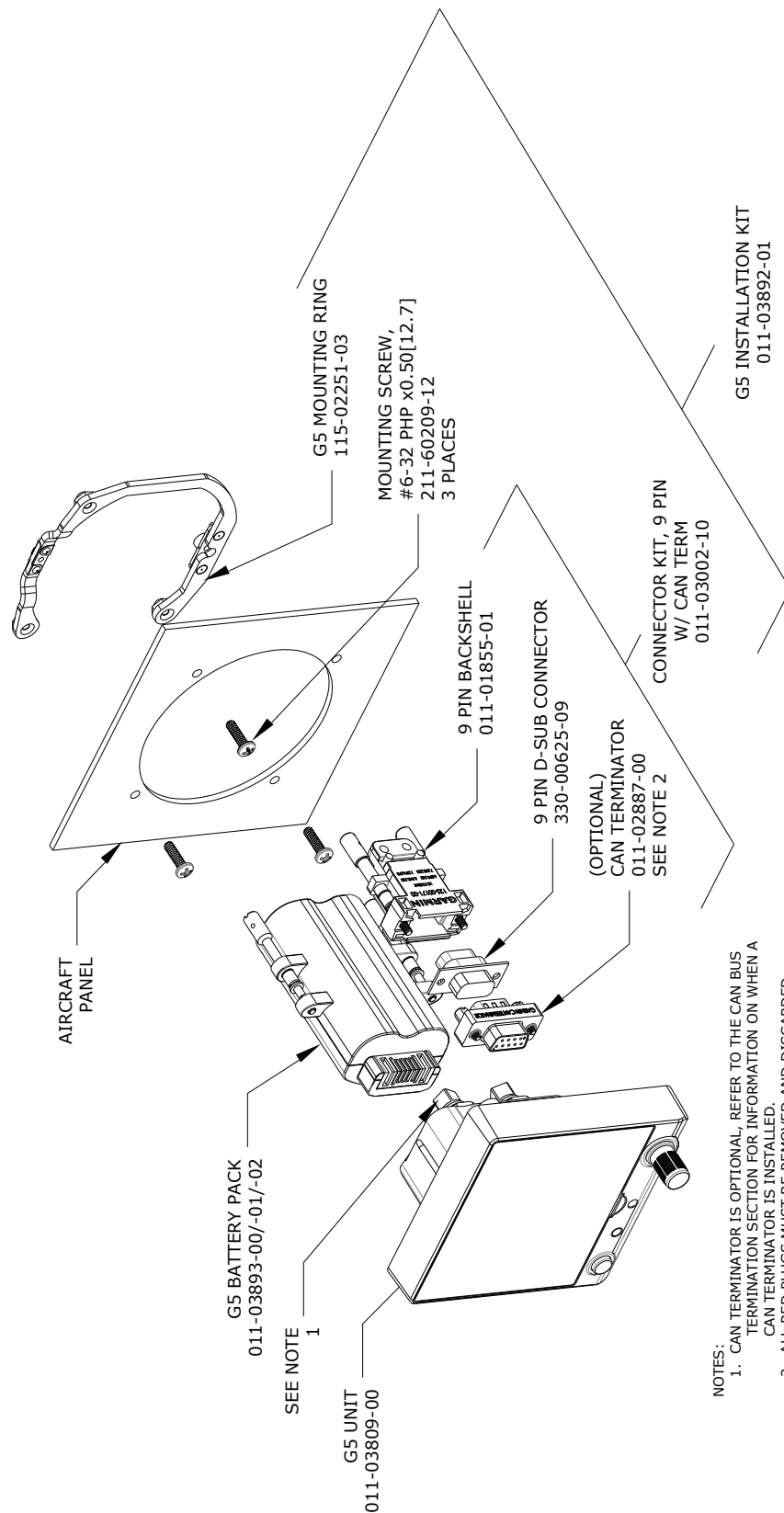
## APPENDIX B - OUTLINE AND INSTALLATION DRAWINGS

### B.1 G5



NOTES:  
 1-1. DIMENSIONS: INCHES[mm]. METRIC VALUES ARE FOR REFERENCE ONLY.  
 1-2. DIMENSIONS ARE NOMINAL AND TOLERANCES

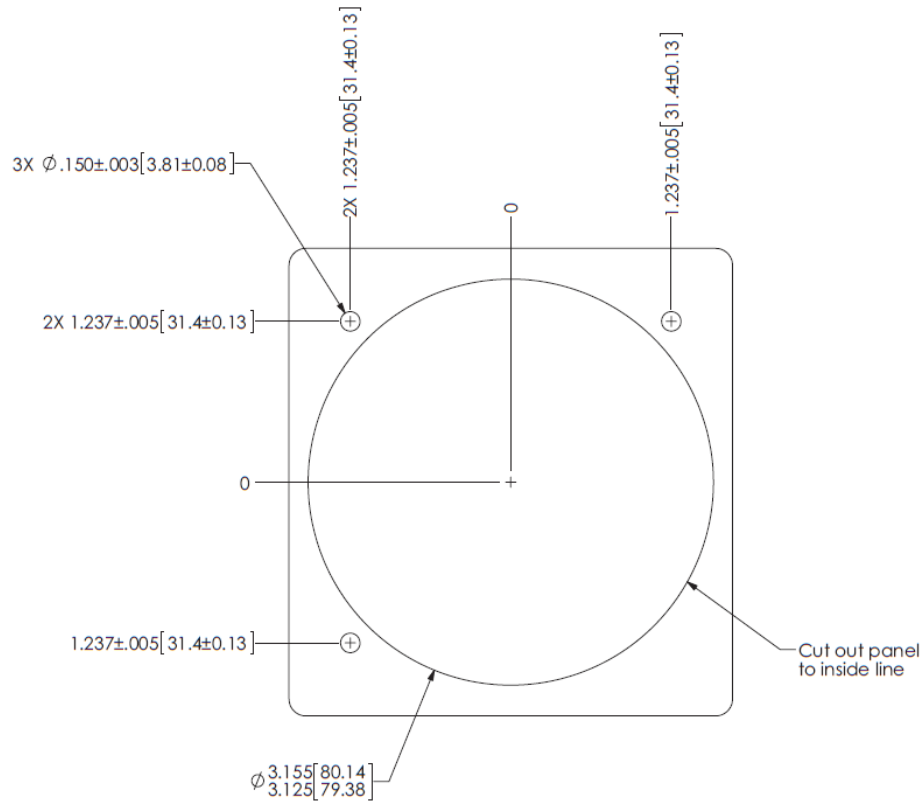
**Figure 6-13 G5 Outline Drawing**



NOTES:

1. CAN TERMINATOR IS OPTIONAL. REFER TO THE CAN BUS TERMINATION SECTION FOR INFORMATION ON WHEN A CAN TERMINATOR IS INSTALLED.
2. ALL RED PLUGS MUST BE REMOVED AND DISCARDED. THEY ARE NOT TO BE USED FOR CAPPING AND SEALING UNUSED PORTS.

**Figure 6-14 G5 Installation Drawing**



**Figure 6-15 G5 Panel Cutout Measurements (Not to Scale)**

*This area intentionally blank*

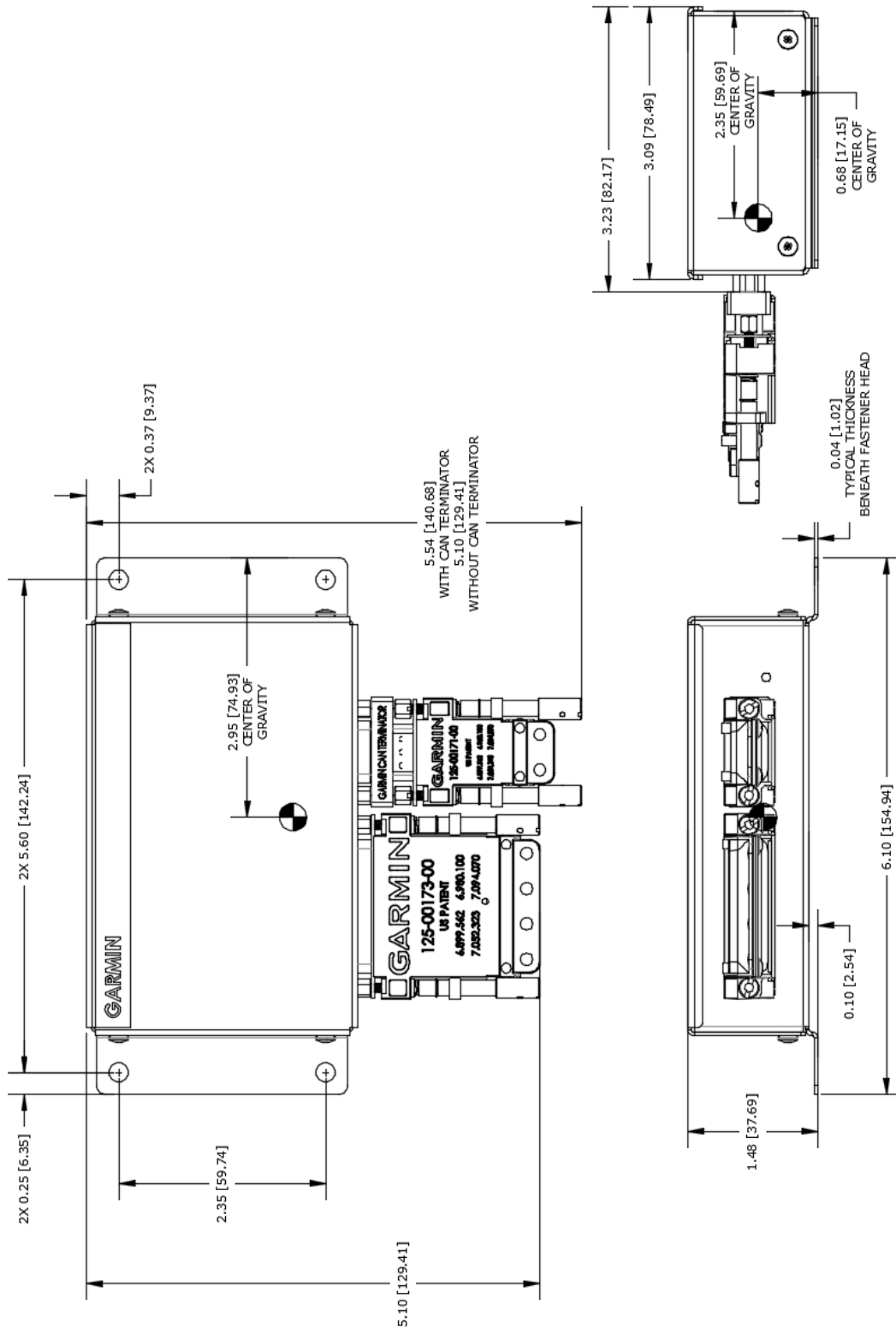


Figure 6-16 GAD 29/29B/29D Outline Drawing

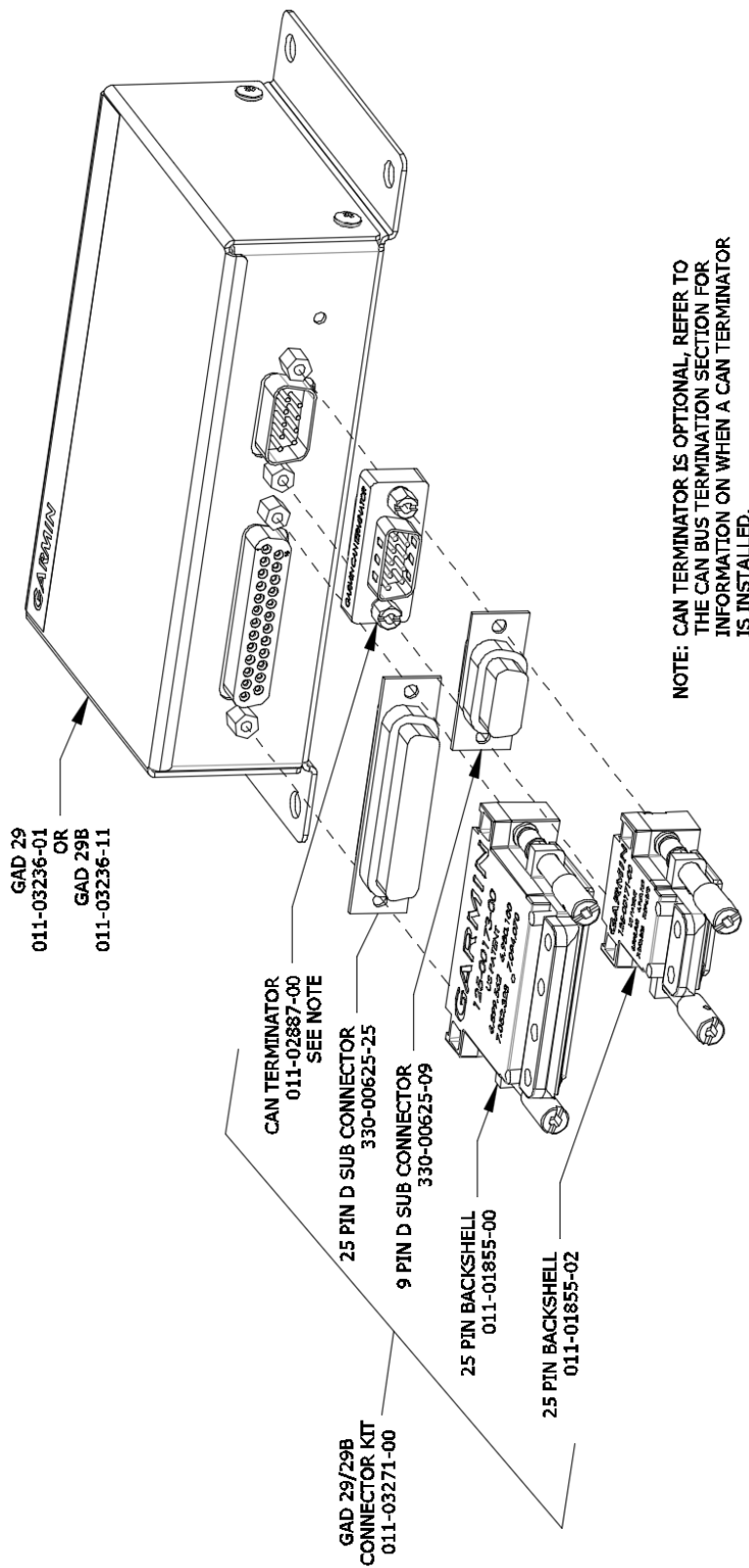


Figure 6-17 GAD 29/29B/29D Install Breakdown

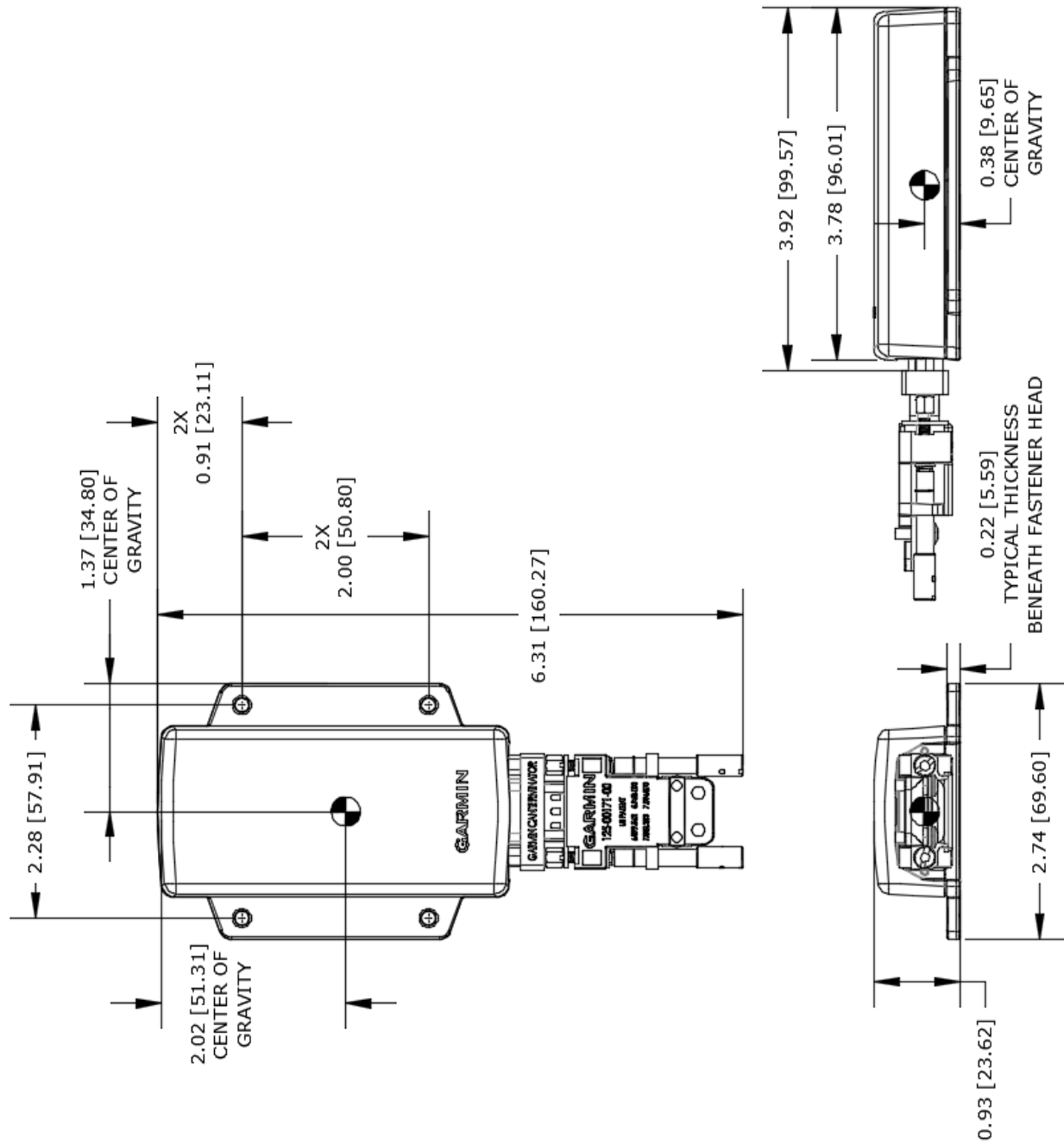


Figure 6-18 GMU 11 Outline Drawing

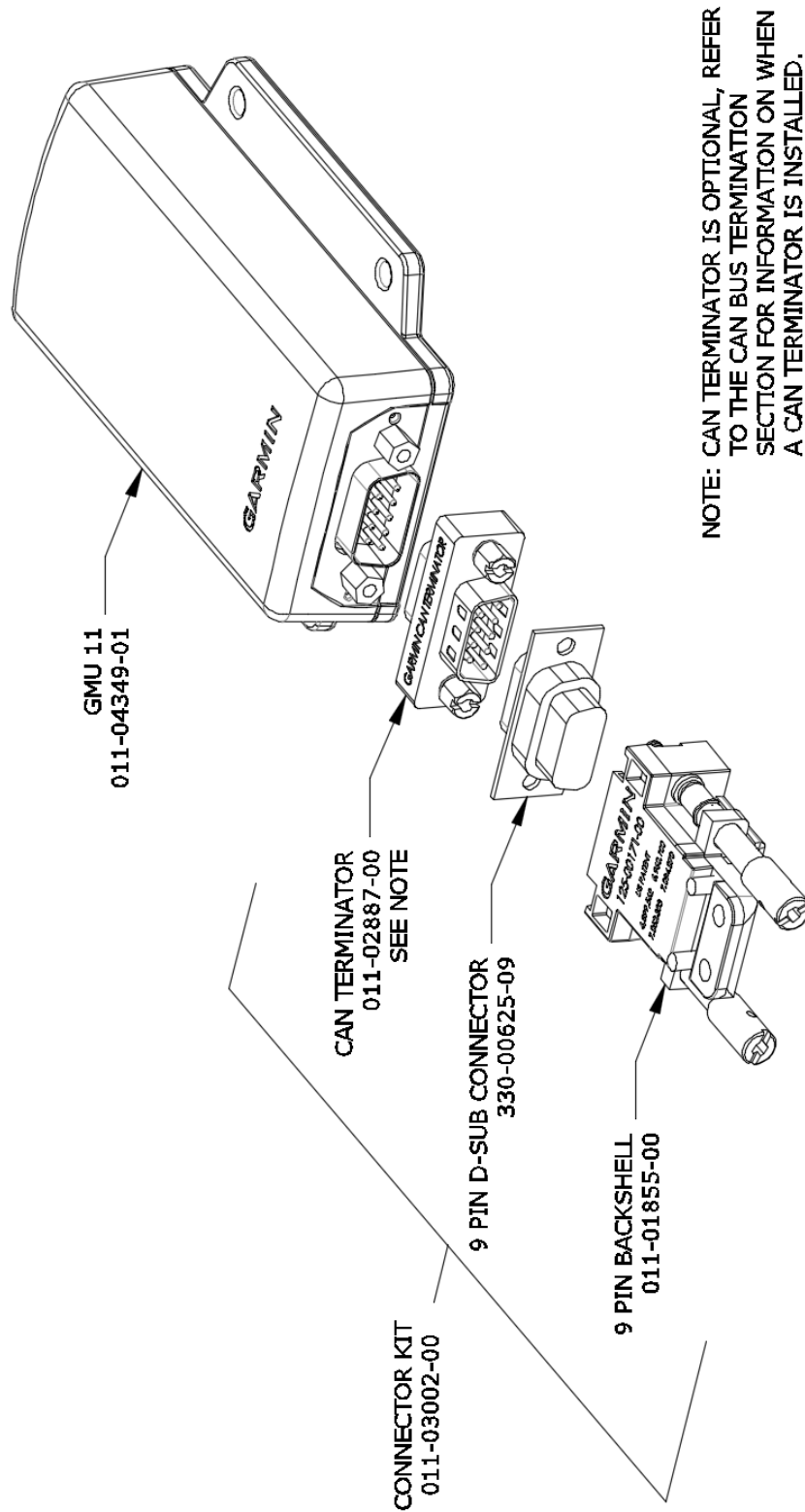


Figure 6-19 GMU 11 Install Breakdown

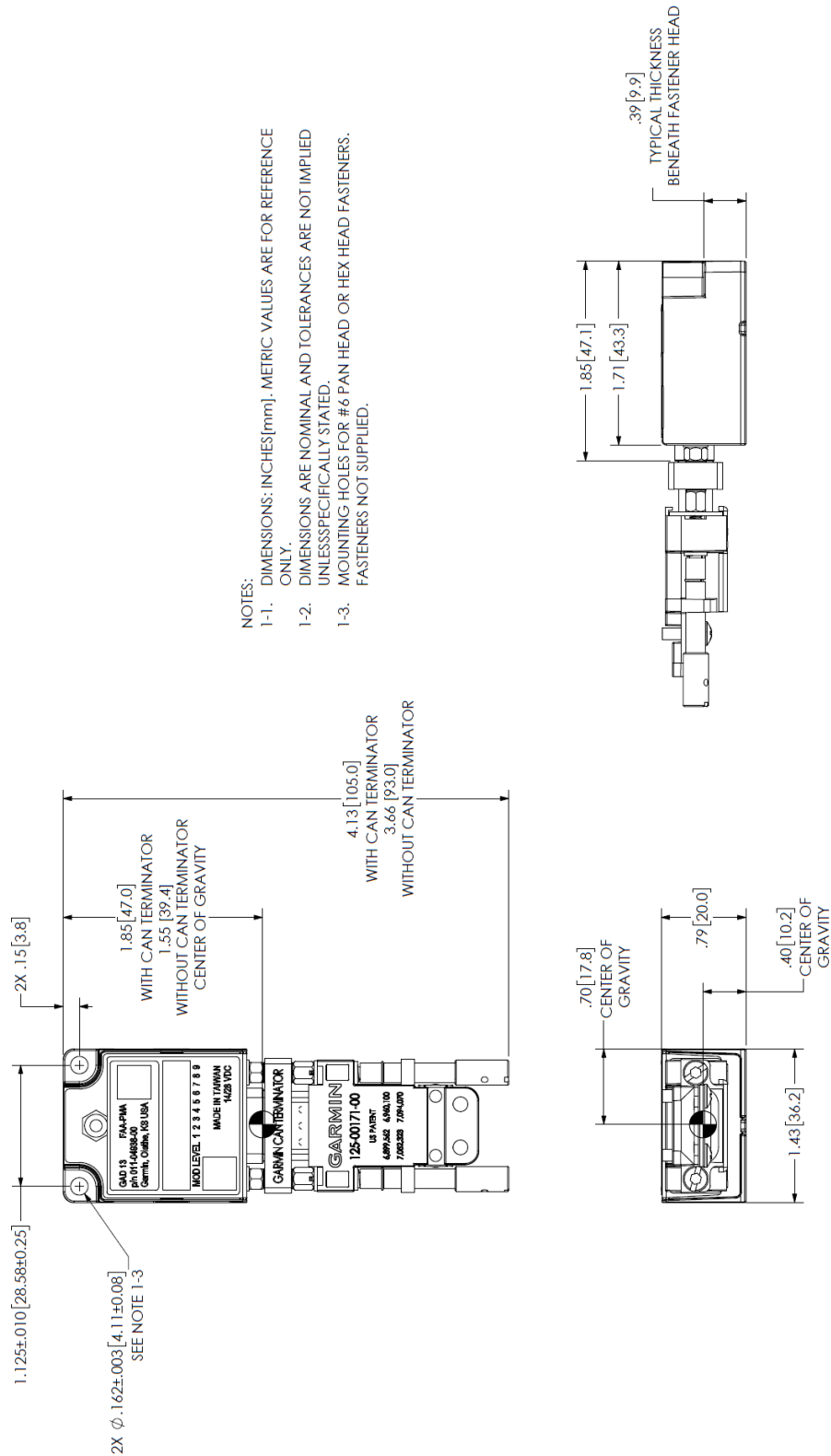
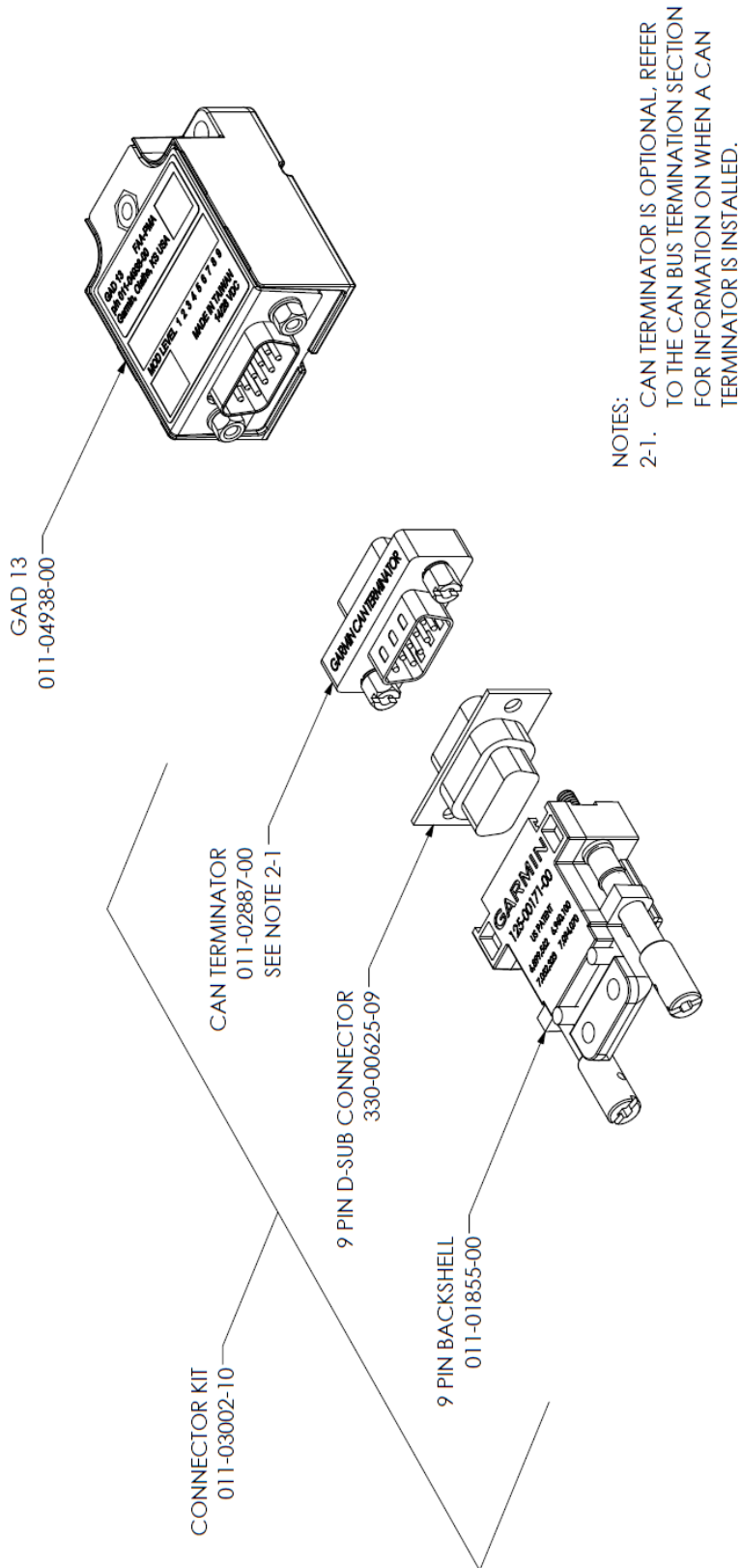


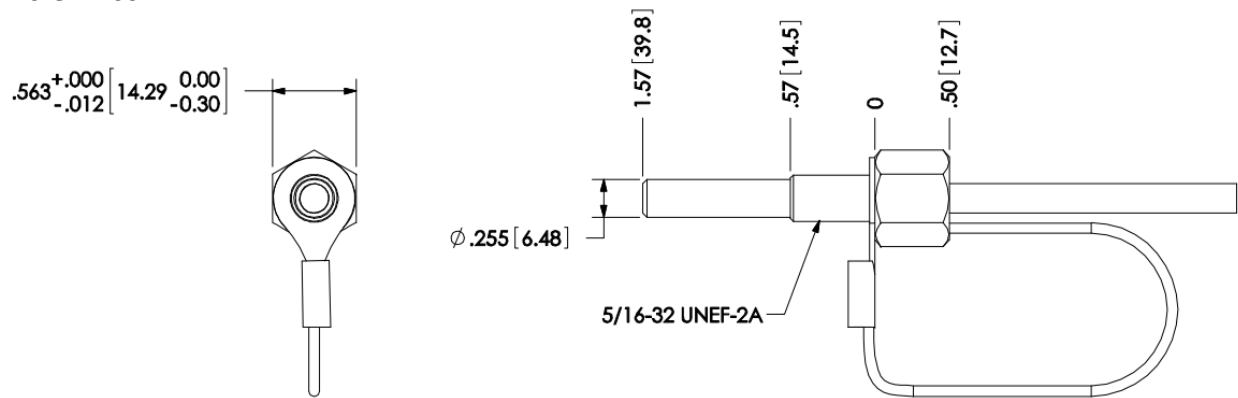
Figure 6-20 GAD 13 Outline Drawing



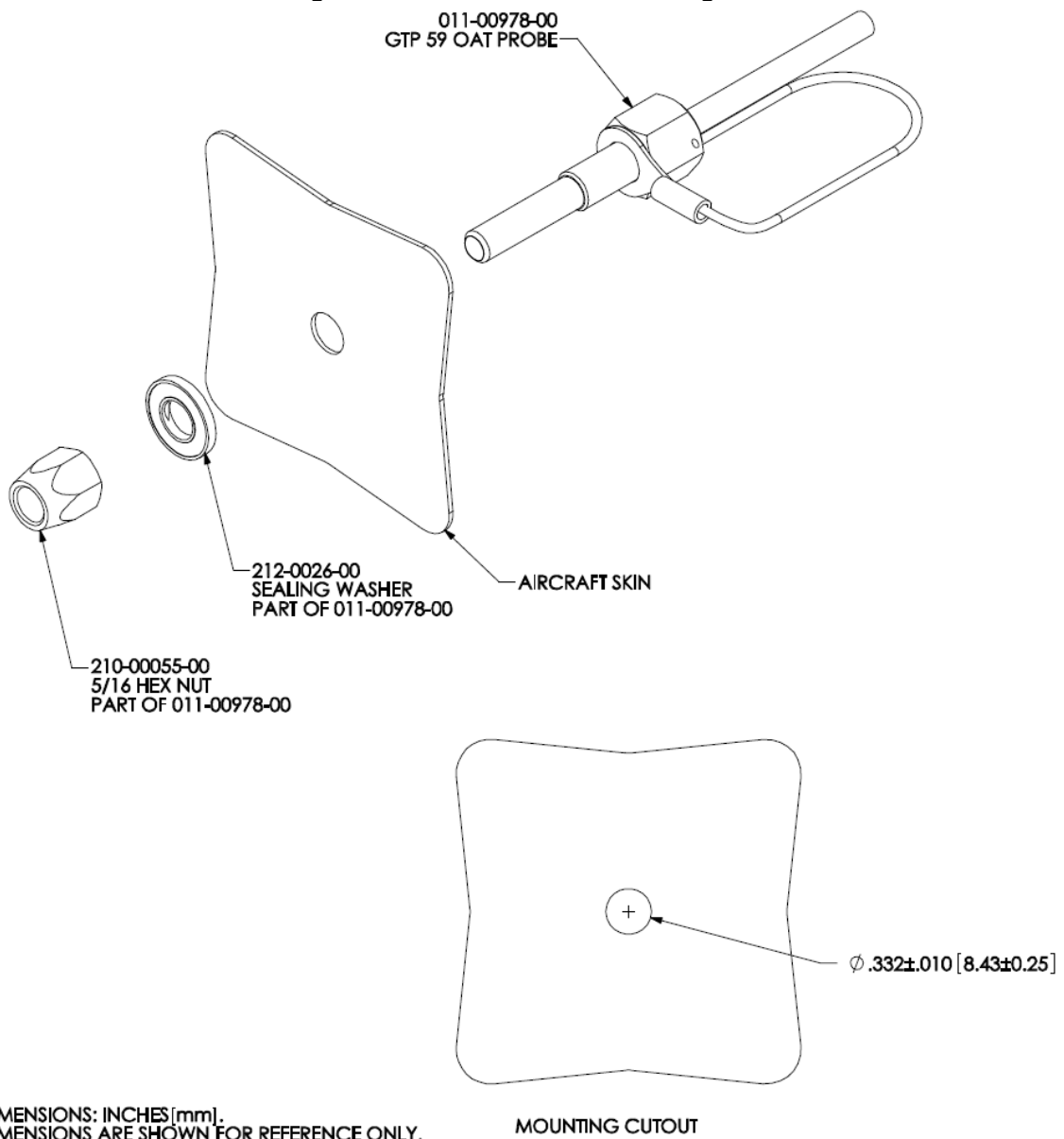


**Figure 6-21 GAD 13 Install Breakdown**

## B.5 GTP 59



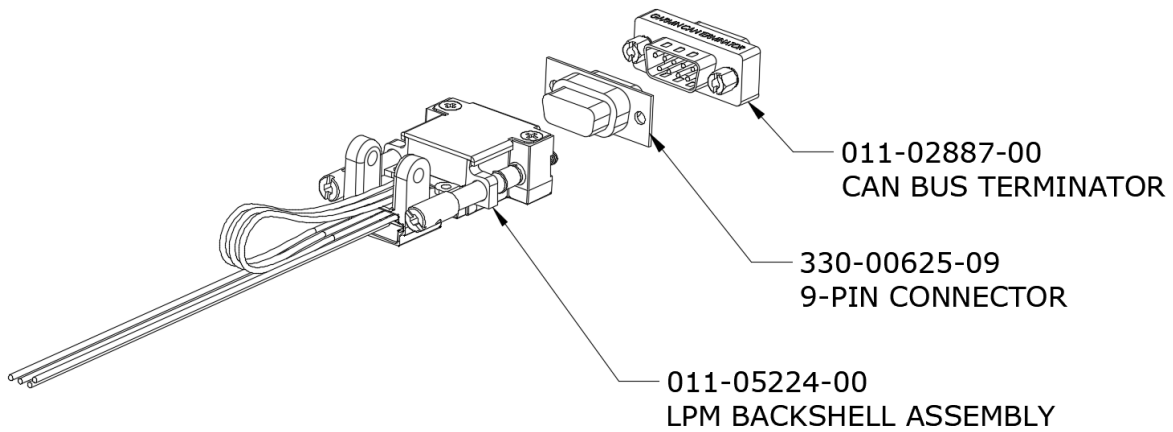
**Figure 6-22 GTP 59 Outline Drawing**



- NOTES:  
 1. DIMENSIONS: INCHES[mm].  
 2. DIMENSIONS ARE SHOWN FOR REFERENCE ONLY.

**Figure 6-23 GTP 59 Install Breakdown**

## B.6 G5 connector Kit Assembly with LPM



011-03002-20 LPM ASSEMBLY

**Figure 6-24 G5 Connector Kit Assembly with LPM (011-03002-20)**

*This area intentionally blank*



## APPENDIX C - MAGNETIC INTERFERENCE SURVEY

### C.1 Introduction

The magnetic interference survey is used to identify a location within an aircraft with acceptable levels of magnetic interference where the GMU 11 can be correctly installed. This appendix describes the materials, precautions, setup, and procedures required to successfully conduct the magnetic interference survey.

### C.2 Required Materials

The following items are required to complete the magnetic interference survey.

#### **DC Power Source**

In order to perform the magnetic interference survey, it is required to use a DC power source capable of supplying 8-36 VDC/350 mA to the G5 and GMU 11 magnetometer for test purposes.

#### **G5**

It is required to use a G5 to run the magnetic interference survey. If a G5 with charged battery attached is used, the G5 does not need to be powered from the DC Power Source.

The GMU 11 will still need power from a DC Power Source. A good temporary power source would be a 9 VDC battery.

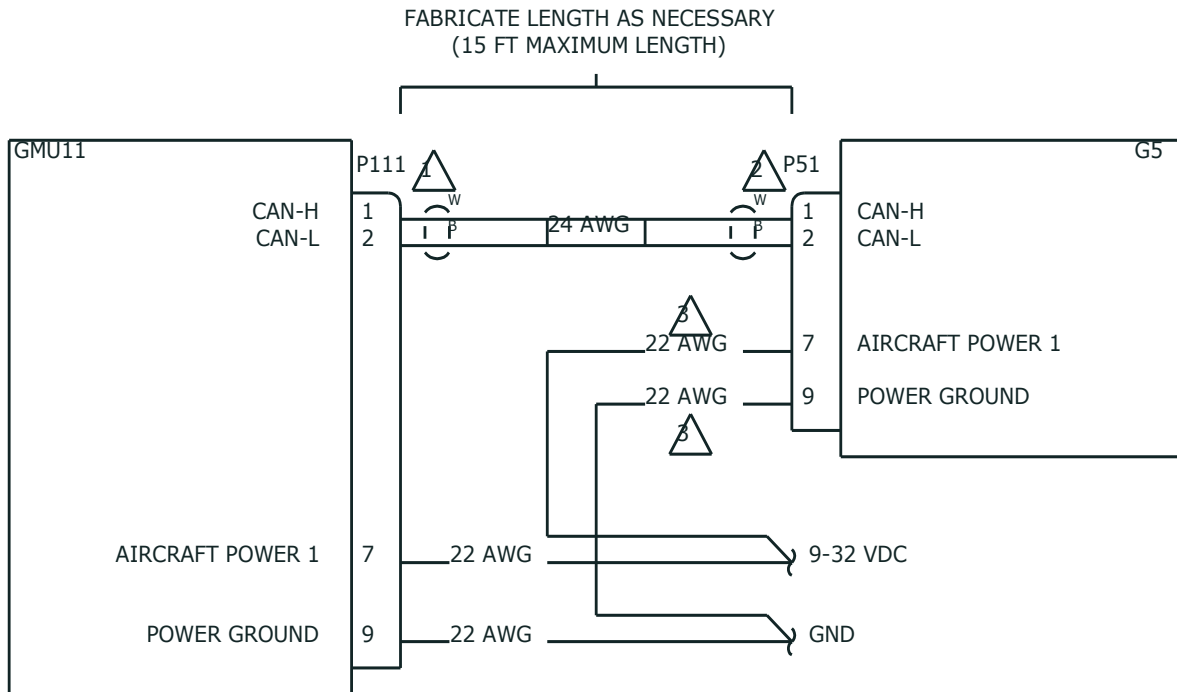
#### **Stopwatch or Watch with a Second Hand**




During the survey test sequence, it is required to use a stopwatch, or watch with a second hand, in order to measure the time for turning equipment on and off.

#### **Magnetic Interference Survey Test Cable**

In order to perform the magnetic interference survey, it is required to use a test cable fabricated by the installer. Fabricate a test cable in accordance with Figure 6-25.

*This area intentionally blank*



-  P111 IS PART OF GARMIN CONNECTOR KIT P/N 011-03002-00. ALTERNATELY, P111 CAN BE MADE USING A TE CONNECTIVITY P/N 1757820-1 OR POSITRONIC P/N RD09F0000X. INSTALL CAN TERMINATION KIT (GARMIN P/N 011-02887-00), PART OF GARMIN CONNECTOR KIT P/N 011-03002-00.
-  P51 IS PART OF GARMIN CONNECTOR KIT P/N 011-03002-00. ALTERNATELY, P51 CAN BE MADE USING A TE CONNECTIVITY P/N 1757820-1 OR POSITRONIC P/N RD09F0000X. INSTALL CAN TERMINATION KIT (GARMIN P/N 011-02887-00), PART OF GARMIN CONNECTOR KIT P/N 011-03002-00.
-  POWER AND GROUND WIRES FOR THE G5 ARE NOT REQUIRED IF A G5 WITH CHARGED BATTERY ATTACHED IS USED FOR THIS TEST SET UP.

**Figure 6-25 Magnetic Interference Test Harness**

### C.3 Conducting the GMU 11 Location Survey

This section describes the setup and procedure required to successfully complete the GMU 11 location survey using the G5.

#### C.3.1 Aircraft and GMU 11 Setup

Prepare the aircraft and GMU 11 for the location survey by completing the following steps:

1. Prepare a detailed survey sequence list with start and stop times for exercising all aircraft components and devices that may affect the operation of the GMU 11 magnetometer through movement of ferrous metal parts or electrical inductance. Aircraft components included on the list will vary depending on aircraft model. An example survey sequence is provided below.
2. Position the aircraft in a magnetically quiet area. This step may involve repositioning large metal objects including aircraft and ground support equipment away from the survey area.
3. Position the GMU 11 in the aircraft location to be surveyed.



**CAUTION**

*Do not permanently install the GMU 11 prior to successfully completing the GMU 11 location survey. An unsurveyed location may be unsuitable for permanent installation and cause the GMU 11 to function incorrectly.*

**Example Survey Sequence**

| A/C Reg.:          |                        | Survey data file name:                                                |
|--------------------|------------------------|-----------------------------------------------------------------------|
| Elapsed Time (sec) | Elapsed Time (min:sec) | Action                                                                |
| 0                  | 0:00                   | Test begins (calibration period – no activity permitted)              |
| 20                 | 0:20                   | Calibration period ends                                               |
| 30                 | 0:30                   | Aileron full right                                                    |
| 40                 | 0:40                   | Aileron full left                                                     |
| 50                 | 0:50                   | Aileron level                                                         |
| 60                 | 1:00                   | Rudder full right                                                     |
| 70                 | 1:10                   | Rudder full left                                                      |
| 80                 | 1:20                   | Rudder neutral                                                        |
| 90                 | 1:30                   | Elevators full up                                                     |
| 100                | 1:40                   | Elevators full down                                                   |
| 110                | 1:50                   | Elevators neutral                                                     |
| 120                | 2:00                   | Flaps down                                                            |
| 140                | 2:20                   | Flaps up                                                              |
| 160                | 2:40                   | Landing gear up                                                       |
| 180                | 3:00                   | Landing gear down                                                     |
| 190                | 3:10                   | Speed brake up                                                        |
| 200                | 3:20                   | Speed brake down                                                      |
| 210                | 3:30                   | Navigation lights on                                                  |
| 220                | 3:40                   | Navigation lights off                                                 |
| 230                | 3:50                   | Landing lights on                                                     |
| 240                | 4:00                   | Landing lights off                                                    |
| 250                | 4:10                   | Taxi lights on                                                        |
| 260                | 4:20                   | Taxi lights off                                                       |
| 270                | 4:30                   | Air conditioning on                                                   |
| 280                | 4:40                   | Air conditioning off                                                  |
| 290                | 4:50                   | Landing lights and taxi lights on                                     |
| 300                | 5:00                   | Landing lights and taxi lights off                                    |
| 310                | 5:10                   | Strobes on                                                            |
| 320                | 5:20                   | Strobes off                                                           |
| 330                | 5:30                   | Recognition lights on                                                 |
| 340                | 5:40                   | Recognition lights off                                                |
| 350                | 5:50                   | Turn on all wingtip lights simultaneously                             |
| 360                | 6:00                   | Turn off all wingtip lights simultaneously                            |
| 370                | 6:10                   | Beacon on                                                             |
| 380                | 6:20                   | Beacon off                                                            |
| 390                | 6:30                   | Autopilot engaged in a pitch and roll made (to engage servo clutches) |
| 400                | 6:40                   | Autopilot disengaged                                                  |
| 410                | 6:50                   | Pitot heat on                                                         |
| 420                | 7:00                   | Pitot heat off                                                        |
| 430                | 7:10                   | End of test                                                           |



### **C.3.2 G5 Tool Setup Procedure and operation**

Before beginning the survey, ensure that all items listed on the test sequence are in their pre-exercise states (e.g. control surfaces neutral, flaps up, lights off). Perform the survey by completing the following steps.

1. Power up the aircraft (master switch, avionics bus, etc.).
2. Connect the test harness to the G5 with a battery installed and an 8-36 VDC/350mA limited power supply as shown in Figure 6-25 above.
3. Turn the G5 on in configuration mode.
4. Navigate to the “Magnetometer” page.
5. Select “Interference Test...”.
6. Follow the instructions displayed on the G5.
7. Select “Start” on the G5.
8. Perform each exercise on the survey sequence sheet. Perform each exercise at its specified elapsed time and for its specified duration. This will help ensure correct identification of magnetic field deviation sources after the survey is complete.
9. Monitor the magnetic field deviation percentage throughout the survey. If deviation levels exceed thresholds, mark the survey sequence exercises during which these deviations occurred.
10. When all exercises in the survey sequence have been completed, the G5 status page will display the worst case percentage of magnetic interference and the time stamp at which it occurred.

### **C.4 G5 Data Analysis**

The G5 status page will display a “Test status:” of either “Pass” or “Fail” and the worst case percentage of magnetic interference and the time stamp at which it occurred. Use this time stamp in conjunction with the completed survey sequence to conclude which item created the highest magnetic interference. If the test passes, then the location chosen for the test is a valid candidate for mounting the GMU 11. No further testing is required.

If the test fails, the location chosen for the test should be considered unreliable until the source of magnetic interference is identified and remedied. Compare the corresponding timestamp with the prepared test sequence to identify which action produced the problem. If the source of the magnet interference is not able to be identified or remedied, a new location for testing should be chosen. Repeat the test until a suitable location is found.

*This area intentionally blank*

## APPENDIX D - GMU 11 MOUNTING IN NONMETALLIC WINGTIP

### D.1 Overview

In some installations it is desirable to mount the GMU 11 magnetometer in the wingtip of a metal aircraft that has non-metallic (e.g. fiberglass) wingtip covers. If this is the case, the following requirements must be met:

- The aircraft must have wingtip navigation lights installed.
- Heavy overbraid must be installed over the wiring from the GMU to the entry into the wing.
- The overbraid must be terminated at this wing entry point using a #10 terminal lug and stud.
- The GMU 11 must be mounted to a metal rib that does not enclose a fuel bay.
- There must be at least one intermediate rib between the rib that encloses the fuel bay and the rib on which the GMU 11 is installed.
- The GMU 11 mounting bracket must be electrically bonded to the wing using fasteners or rivets.

### D.2 Materials Required but Not Supplied

The following materials (or equivalents) are required to install the GMU 11 in a non-metallic wingtip:

- Tinned copper flat braid, 1/4", QQB575F36T0250
- Electrical tie-down strap, adjustable, MS3367-{1, 2, or 7}-X
- Terminal lug, #10, insulated, MS25036-108
- Terminal stud, #10
- Terminal lug, #8, insulated, MS25036-153

### D.3 Overbraid Fabrication and Installation

The length of overbraid required is approximately equal to the length of the GMU 11 service loop (measured from the wing rib to the collar of P111) plus 4 inches.

Refer to Figure 6-26 and Figure 6-27 while completing the following overbraid installation procedure:



#### NOTE

*It is recommended this procedure is completed prior to terminating wires to connector P111. If this procedure is completed before assembly of P111, proceed to step 3.*

1. Disconnect P111 from the GMU 11.
2. De-pin wires from P111 to facilitate placing overbraid over wire bundle.
3. Slide the overbraid over wire bundle extending from wing rib.
4. Terminate the end nearest the metal wing rib with the overbraid in accordance with one of the two methods in Section D.3.1 using a #8 terminal lug.
5. Secure the overbraid pigtail to the shield block of P111 when assembling P111 (Refer to Section 4.2.3).
6. Terminate the end nearest the GMU with the overbraid in accordance with one of the two methods in Section D.3.1 using a #10 terminal lug.
7. Secure the overbraid pigtail to a #10 terminal stud. Refer to Section D.3.2 for stud location instructions.



## D.3.1 Overbraid Termination Methods

Overbraid must be terminated with an appropriate lug by one of the two following approved methods. Whichever method is used, overbraid pigtail length must not exceed two inches. Refer to Figure 6-27.

### Method A

1. Carefully separate overbraid wire strands by hand to create an opening in the overbraid for passage of the GMU 11 connector and cables.



### CAUTION

*Do not cut an opening in the overbraid strands. Loose overbraid wire ends can chafe the cable and cause the GMU 11 to malfunction.*

2. Trim the overbraid pigtail to a maximum length of two inches.
3. Terminate the braid pigtail in an appropriate terminal lug.

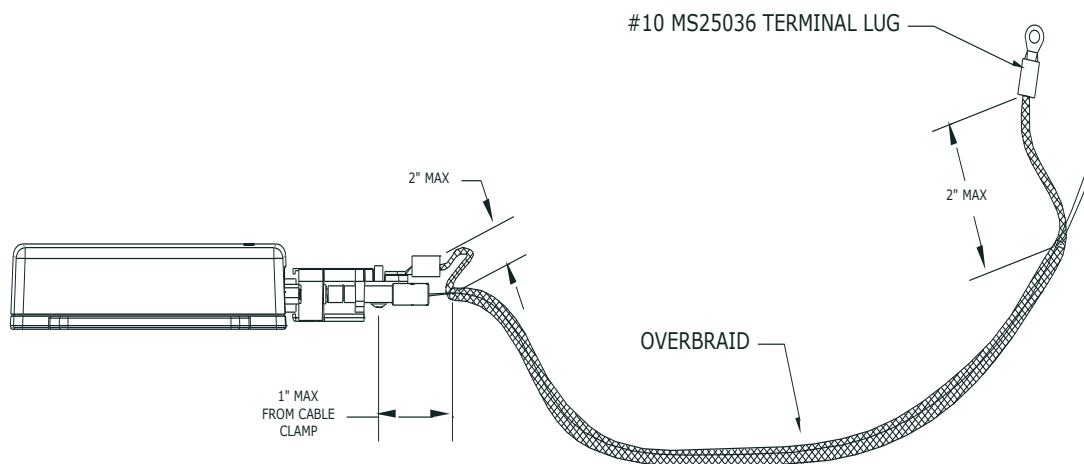
### Method B

1. Comb out a maximum of two inches of overbraid pigtail.
2. Twist the pigtail and terminate it in an appropriate terminal lug.

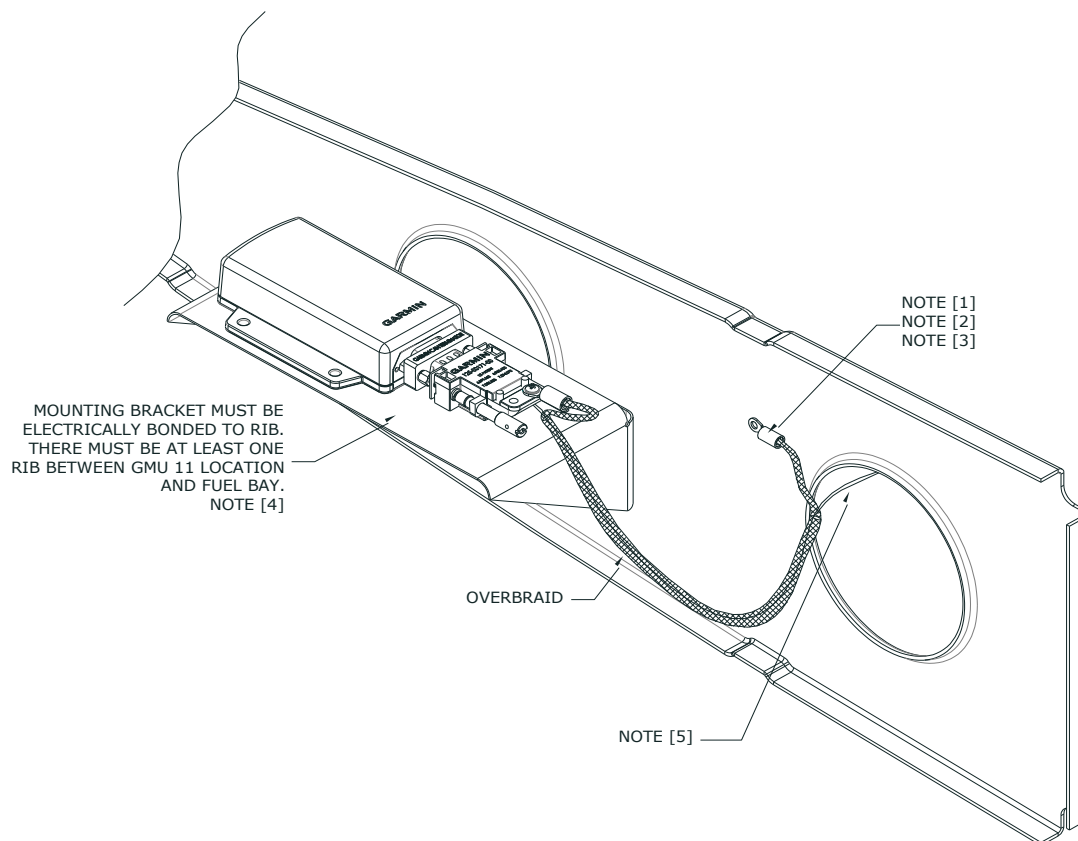
## D.3.2 Overbraid Terminal Bonding

Electrical bond preparation for all aluminum-to-aluminum interfaces must be done in accordance with SAE ARP1870 section 5.1 and 5.5. The overbraid terminal lug must be electrically bonded to a #10 stud installed in accordance with AC43.13-1B Section 11-189, as well as the following restrictions:

1. If possible, use an existing tooling hole to install the stud.
2. If no suitable tooling hole exists, use an existing fastener (#10 or larger).
3. If there is no suitable fastener, install a new #10 stud as follows:
  - a. When adding a new stud hole to the rib, the center of the hole must be located a minimum of one inch away from any existing, non-stiffened rib hole.
  - b. The new stud hole must be located such that the terminal lug face, neck, or attaching hardware will not intrude into the flange bend radius of any rib edge or stiffened rib hole. Refer to SAE AS25036 for terminal lug dimensions.
4. Verify overbraid terminal bonding by checking resistance between the overbraid and the rib. Resistance should be less than 2.5 mΩ. For installations with overbraid length in excess of 10-inches refer to Section 4.5 for electrical bonding requirements.



**Figure 6-26 GMU 11 Overbraid Installation**



**NOTES:**

- [1] Install #10 grounding hardware in accordance with AC 43.13-1B, section 11-189. If there is an existing hole located in an appropriate area it may be utilized for the grounding hardware. If there is no existing hole usable for this purpose then drill and de-burr a 0.196"-0.206" hole.
- [2] MS25036-103 terminal lug (or equivalent).
- [3] Terminal lug face or connecting hardware must not interfere with bend radius of rib edge or stiffened holes. Stud hole must be located a minimum 1" from unstiffened holes. Refer to SAE AS25036 for lug dimensions.
- [4] If the overbraid length is less than 10-inches, no additional bonding strap per Section 4.5 is required. For installations with overbraid length in excess of 10-inches refer to Section 4.5 for electrical bonding requirements.
- [5] The exposed cable not having overbraid in the wing tip areas must be 6 inches or less. If wiring is not over braided, a bonding strap will need to be installed as described in section 4.5.

**Figure 6-27 GMU 11 Overbraid Termination**



## APPENDIX E - MODEL SPECIFIC DATA

This appendix provides the following information for every model listed on the AML:

- The lightning zoning figures from APPENDIX F that are applicable to a particular aircraft model.
- Suitable lightning zones for installation of the GTP 59 Temperature Probe, GMU 11 Magnetometer in a particular aircraft model. For additional information, refer to Section 4.1.7 for GTP 59, Section 4.1.3 for GMU 11
- Any notes related to a particular aircraft model.



### **NOTE**

*Any aircraft model listed in Table 6-3 and not explicitly called out as nonmetallic by an end note should be considered an all-metal aircraft.*



**Table 6-3: Aircraft Model-Specific Data**

| Airplane Make (TCDS Holder) [common name or previous make]                                                      | Airplane Model Designation                                                | Lightning Zone Type (Ref. Appendix F) |             |             | GTP 59 Location        | GMU 11 Location         | Notes                                             |
|-----------------------------------------------------------------------------------------------------------------|---------------------------------------------------------------------------|---------------------------------------|-------------|-------------|------------------------|-------------------------|---------------------------------------------------|
|                                                                                                                 |                                                                           | Wing                                  | Fuselage    | Empennage   |                        |                         |                                                   |
| <b>Aermacchi S.p.A</b><br>(Aermacchi S.p.A) [Siai Marchetti]                                                    | F.260, F.260B, F.260C, F.260D, F.260E, F.260F                             | Figure 6-28, Figure 6-30              | Figure 6-31 | Figure 6-41 | Zone 3, Zone 2A [1][2] | All [5][7]              |                                                   |
| <b>Aermacchi S.p.A</b><br>(Aermacchi S.p.A) [Siai Marchetti]                                                    | S.205-18/F, S.205-18/R, S.205-20/F, S.205-20/R, S.205-22/R, S.208, S.208A | Figure 6-28, Figure 6-30              | Figure 6-31 | Figure 6-41 | Zone 3, Zone 2A [1][2] | All [5][7]              |                                                   |
| <b>Aero Commander</b><br>(Dynac Aerospace Corp) [Voltaire]                                                      | 10, 10A, 100, 100A, 100-180                                               | Figure 6-28, Figure 6-30              | Figure 6-31 | Figure 6-41 | Zone 3, Zone 2A [1][2] | All [5][7]              |                                                   |
| <b>Aerostar</b> (Aerostar Aircraft Corporation)                                                                 | PA-60-600 (Aerostar 600), PA-60-601 (Aerostar 601)                        | Figure 6-28, Figure 6-30              | Figure 6-31 | Figure 6-41 | Zone 3, Zone 2A [1][2] | All [5][7]              | Ensure compliance with AD 74-25-02 if applicable. |
| <b>Aerostar</b> (Aerostar Aircraft Corporation)                                                                 | PA-60-601P (Aerostar 601P), PA-60-602P (Aerostar 602P)                    | Figure 6-28, Figure 6-30              | Figure 6-35 | Figure 6-41 | Zone 3, Zone 2A [1][2] | All [5][7]              | Ensure compliance with AD 74-25-02 if applicable. |
| <b>Aeromere</b> (Aeromere S.A.) [Falco]                                                                         | Falco F.8.L                                                               | Figure 6-29, Figure 6-30              | Figure 6-31 | Figure 6-41 | Zone 3 [4]             | All (fuselage only) [6] | Installation approved for VFR operation only. [8] |
| <b>Aeronautica Macchi Aerfer</b> (Aeronautica Macchi S.p.A. & Aerfer-Industrie Aerospaziali Meridionali S.p.A.) | AM-3                                                                      | Figure 6-29, Figure 6-30              | Figure 6-31 | Figure 6-41 | Zone 3, Zone 2A [1][2] | All [5][7]              |                                                   |
| <b>Airbus Defense and Space GMBH</b> (Airbus Defense and Space GMBH) [Bolkow]                                   | Bolkow Jr.                                                                | Figure 6-28, Figure 6-30              | Figure 6-31 | Figure 6-41 | Zone 3, Zone 2A [1][2] | All [5][7]              |                                                   |



| Airplane Make (TCDS Holder) [common name or previous make]                    | Airplane Model Designation                               | Lightning Zone Type (Ref. Appendix F) |                          |             | GTP 59 Location        | GMU 11 Location                            | Notes |
|-------------------------------------------------------------------------------|----------------------------------------------------------|---------------------------------------|--------------------------|-------------|------------------------|--------------------------------------------|-------|
|                                                                               |                                                          | Wing                                  | Fuselage                 | Empennage   |                        |                                            |       |
| <b>Airbus Defense and Space GMBH</b> (Airbus Defense and Space GMBH) [Bolkow] | BO-209-150 FV & RV, BO-209-160 FV & RV, BO-209-150 FF    | Figure 6-28, Figure 6-30              | Figure 6-31              | Figure 6-41 | Zone 3, Zone 2A [1][2] | All [5][7]                                 |       |
| <b>Alexandria Aircraft</b> (Alexandria Aircraft, LLC) [Bellanca]              | 14-19, 14-19-2, 14-19-3, 14-19-3A, 17-30, 17-31, 17-31TC | Not Allowed                           | Figure 6-31              | Figure 6-41 | Zone 2A [1][3]         | All (except wing) [5]                      | [8]   |
| <b>Alexandria Aircraft</b> (Alexandria Aircraft LLC) [Bellanca]               | 17-30A, 17-31A, 17-31ATC                                 | Not Allowed                           | Figure 6-31              | Figure 6-41 | Zone 2A [1][3]         | All (except wing) [5]                      | [8]   |
| <b>Alpha Aviation Concept Ltd</b> (Alpha Aviation Concept Limited)            | R2160                                                    | Figure 6-29, Figure 6-30              | Figure 6-31              | Figure 6-41 | Zone 3, Zone 2A [1][2] | All [5][7]                                 |       |
| <b>American Champion</b> (American Champion Aircraft Corporation)             | 7ECA, 7GCAA, 7GCBC, 7KCAB                                | Not Allowed                           | Figure 6-31              | Figure 6-41 | Zone 3, Zone 2A [1][3] | All (except wing) [5]                      | [8]   |
| <b>American Champion</b> (American Champion Aircraft Corporation)             | 8KCAB, 8GCBC                                             | Not Allowed                           | Figure 6-31              | Figure 6-41 | Zone 3, Zone 2A [1][3] | All (except wing) [5]                      | [8]   |
| <b>APEX Aircraft</b> (APEX Aircraft) [AVIONS MUDRY et CIE]                    | CAP 10B                                                  | Figure 6-29, Figure 6-30              | Figure 6-31,             | Figure 6-41 | Not Allowed            | All (except wing) [5]                      | [8]   |
| <b>Aviat Aircraft, Inc.</b> (Aviat Aircraft, Inc.) [Sky International]        | A-1, A-1A, A-1B, A-1C-180, A-1C-200                      | Figure 6-28, Figure 6-30              | Figure 6-31              | Figure 6-41 | Zone 3, Zone 2A [1][3] | All (fuselage and emp.), Zone 3 (wing) [5] | [8]   |
| <b>Aviat Aircraft, Inc.</b> (Aviat Aircraft, Inc.) [Sky International]        | S-1S, S-1T, S-2, S-2A, S-2S, S-2B, S-2C                  | Not Allowed                           | Figure 6-31, Figure 6-40 | Figure 6-41 | Zone 3, Zone 2A [1][2] | All (except wing) [5]                      | [8]   |
| <b>Bellanca</b> (Bellanca Aircraft Corporation)                               | 14-13-2, 14-13-3W, 14-13-3, 14-13                        | Not Allowed                           | Figure 6-31              | Figure 6-41 | Zone 3, Zone 2A [1][3] | All (except wing) [5]                      | [8]   |



| Airplane Make (TCDS Holder) [common name or previous make]     | Airplane Model Designation                                                                          | Lightning Zone Type (Ref. Appendix F) |                                                          |             | GTP 59 Location        | GMU 11 Location                            | Notes   |
|----------------------------------------------------------------|-----------------------------------------------------------------------------------------------------|---------------------------------------|----------------------------------------------------------|-------------|------------------------|--------------------------------------------|---------|
|                                                                |                                                                                                     | Wing                                  | Fuselage                                                 | Empennage   |                        |                                            |         |
| <b>Boeing Airplane Company</b> (Boeing) [Boeing-Stearman]      | A75L3, 75, A75, B75, E75, A75J1, A75L300, A75N1, B75N1, D75N1, IB75A, E75N1                         | Not Allowed                           | Figure 6-31, Figure 6-40                                 | Figure 6-41 | Zone 2 [1][3]          | All (except wing) [5]                      | [8]     |
| <b>Boeing</b> (The Boeing Company) [Rockwell International]    | BC-1A, AT-6 (SNJ-2), AT-6A (SNJ-3), AT-6B, AT-6C (SNJ-4), AT-6D (SNJ-5), AT-6F (SNJ-6), SNJ-7, T-6G | Figure 6-28, Figure 6-30              | Figure 6-31                                              | Figure 6-41 | Zone 3, Zone 2A [1][2] | All [5][7]                                 |         |
| <b>Cessna</b> (Cessna Aircraft Company)                        | T-50 (Army AT-17, and UC-78 series, and Navy JRC-1)                                                 | Not Allowed                           | Figure 6-35 (for tube-and-fabric; otherwise not allowed) | Not Allowed | Zone 2A [1][3]         | All (fuselage only) [5]                    | [8]     |
| <b>Cessna</b> (Regal Air Incorporated)                         | 305A, 305C, 305D, 305F                                                                              | Figure 6-28, Figure 6-30              | Figure 6-31                                              | Figure 6-41 | Zone 3, Zone 2A [1][2] | All [5][7]                                 |         |
| <b>Cessna</b> (Regal Air Incorporated)                         | 305B, 305E                                                                                          | Figure 6-28, Figure 6-30              | Figure 6-31                                              | Figure 6-41 | Zone 3, Zone 2A [1][2] | All [5][7]                                 |         |
| <b>Cirrus Design Corporation</b> (Cirrus Design Corporation)   | SR20, SR22, SR22T                                                                                   | Figure 6-28, Figure 6-30              | Figure 6-31                                              | Figure 6-41 | Zone 3 [4]             | All (fuselage and emp.), Zone 3 (wing) [6] | [8][10] |
| <b>Commander</b> (Commander Aircraft Corporation) [CPAC, Inc.] | 112, 112TC, 112B, 112TCA, 114, 114A, 114B, 114TC                                                    | Figure 6-28, Figure 6-30              | Figure 6-31                                              | Figure 6-41 | Zone 3, Zone 2A [1][2] | Zone 3, Zone 2A [5][7]                     |         |



| Airplane Make (TCDS Holder) [common name or previous make]                                      | Airplane Model Designation                                          | Lightning Zone Type (Ref. Appendix F) |             |             | GTP 59 Location        | GMU 11 Location                     | Notes                                                                                                                                                  |
|-------------------------------------------------------------------------------------------------|---------------------------------------------------------------------|---------------------------------------|-------------|-------------|------------------------|-------------------------------------|--------------------------------------------------------------------------------------------------------------------------------------------------------|
|                                                                                                 |                                                                     | Wing                                  | Fuselage    | Empennage   |                        |                                     |                                                                                                                                                        |
| <b>Costruzioni Aeronautiche Tecnam S.P.A.</b> (Costruzioni Aeronautiche Tecnam S.P.A.) [Tecnam] | P2006T                                                              | Figure 6-28, Figure 6-30              | Figure 6-37 | Figure 6-41 | Zone 3, Zone 2A [1][2] | All [5][7]                          | Existing Attitude indicator must be retained. The G5 can be installed as a secondary Attitude indicator. The G5 cannot be installed as an HSI          |
| <b>Costruzioni Aeronautiche Tecnam S.P.A.</b> (Costruzioni Aeronautiche Tecnam S.P.A.) [Tecnam] | P2010                                                               | Figure 6-28, Figure 6-30              | Figure 6-31 | Figure 6-41 | Zone 3 [4]             | Zone 3 [6]                          | Existing Attitude indicator must be retained. The G5 can be installed as a secondary Attitude indicator. The G5 cannot be installed as an HSI. [8][10] |
| <b>Cougar</b> (Cougar Aircraft Corporation)[SOCATA S.A.] [Grumman]                              | GA-7 (Cougar)                                                       | Figure 6-28, Figure 6-30              | Figure 6-35 | Figure 6-41 | Zone 3, Zone 2A [1][2] | All [5][7]                          |                                                                                                                                                        |
| <b>Cub Crafters</b> (Cub Crafters Inc.)                                                         | CC19-180                                                            | Figure 6-29, Figure 6-30              | Figure 6-31 | Figure 6-41 | Zone 3, Zone 2A [1][3] | All [5][7]                          |                                                                                                                                                        |
| <b>DeHavilland Support Limited</b>                                                              | Beagle B.121 Series 1, Beagle B.121 Series 2, Beagle B.121 Series 3 | Figure 6-28, Figure 6-30              | Figure 6-31 | Figure 6-41 | Zone 3, Zone 2A [1][2] | All [5][7]                          |                                                                                                                                                        |
| <b>Diamond</b> (Diamond Aircraft Industries, Inc.)                                              | DA20-A1, DA20-C1                                                    | Figure 6-29, Figure 6-30              | Figure 6-31 | Figure 6-41 | Zone 3 [4]             | Zone 3, Zone 2A (fuselage only) [6] | Installation approved for VFR operation only. [8]                                                                                                      |



| Airplane Make (TCDS Holder) [common name or previous make]                       | Airplane Model Designation                                         | Lightning Zone Type (Ref. Appendix F) |             |             | GTP 59 Location        | GMU 11 Location             | Notes                                                   |
|----------------------------------------------------------------------------------|--------------------------------------------------------------------|---------------------------------------|-------------|-------------|------------------------|-----------------------------|---------------------------------------------------------|
|                                                                                  |                                                                    | Wing                                  | Fuselage    | Empennage   |                        |                             |                                                         |
| <b>Diamond</b> (Diamond Aircraft Industries, Inc)                                | DA 40, DA 40F, DA 40 NG VFR Version (with no lightning protection) | Figure 6-29, Figure 6-30              | Figure 6-31 | Figure 6-41 | Zone 3 [4]             | Zone 3 [6]                  | [8]                                                     |
| <b>Diamond</b> (Diamond Aircraft Industries, Inc)                                | DA 40, DA 40F, DA 40 NG                                            | Figure 6-28, Figure 6-30              | Figure 6-31 | Figure 6-41 | Zone 3 [4]             | Zone 3 [6]                  | Must have Diamond SB OSB 40-004/3 incorporated. [8][10] |
| <b>EADS-PZL "Warszawa-Okecie"</b> (EADS-PZL "Warszawa-Okecie" S.A.)              | PZL-104 WILGA 80, PZL-104M WILGA 2000, PZL-104MA WILGA 2000        | Figure 6-28, Figure 6-30              | Figure 6-31 | Figure 6-41 | Zone 3, Zone 2A [1][2] | All [5][7]                  |                                                         |
| <b>EADS-PZL "Warszawa-Okecie"</b> (EADS-PZL "Warszawa-Okecie" S.A.)              | PZL-KOLIBER 150A, PZL-KOLIBER 160A                                 | Figure 6-28, Figure 6-30              | Figure 6-31 | Figure 6-41 | Zone 3, Zone 2A [1][2] | All [5][7]                  |                                                         |
| <b>Extra</b> (Extra Flugzeugproduktions- und Vertriebs- GmbH)                    | EA-300L, EA-300S, EA-300/200, EA-300, EA 300/LC                    | Not Allowed                           | Figure 6-31 | Figure 6-41 | Zone 3, Zone 2A [1][3] | All (except wing) [5]       | [8]                                                     |
| <b>FFT-GmbH</b> (FFT Gesellschaft für Flugzeug - & Faserverbund-Technologie mbH) | SC01 B-160 Gyroflug Speed Canard                                   | Figure 6-29                           | Figure 6-32 | Not Allowed | Not Allowed            | All (fuselage and wing) [5] | GTP59 installation not allowed. [8]                     |
| <b>Fleet Aircraft, Ltd</b> (Flight Aircraft Ltd)                                 | FLEET 80                                                           | Figure 6-28, Figure 6-30              | Figure 6-31 | Figure 6-41 | Zone 3, Zone 2A [3]    | All [5]                     | [8]                                                     |
| <b>Frakes Aviation</b> (Frakes Aviation) [Gulfstream American Corporation]       | G-44, G-44A, SCAN Type 30                                          | Figure 6-28, Figure 6-30              | Figure 6-35 | Figure 6-41 | Zone 3, Zone 2A [1][2] | All [5][7]                  |                                                         |





| Airplane Make (TCDS Holder) [common name or previous make]                                       | Airplane Model Designation                                 | Lightning Zone Type (Ref. Appendix F)                          |             |             | GTP 59 Location        | GMU 11 Location       | Notes                                                                                                                                                       |
|--------------------------------------------------------------------------------------------------|------------------------------------------------------------|----------------------------------------------------------------|-------------|-------------|------------------------|-----------------------|-------------------------------------------------------------------------------------------------------------------------------------------------------------|
|                                                                                                  |                                                            | Wing                                                           | Fuselage    | Empennage   |                        |                       |                                                                                                                                                             |
| <b>Pacific Aerospace Limited. (Pacific Aerospace Ltd.)</b> (Found Aircraft Canada, Inc.)         | FBA-2C, FBA-2C1 (Bush Hawk), FBA-2C2 (Bush Hawk XP)        | Figure 6-28, Figure 6-30                                       | Figure 6-31 | Figure 6-41 | Zone 3, Zone 2A [1][2] | All [5][7]            |                                                                                                                                                             |
| <b>Found Brothers</b> (Found Brothers Aviation Limited)                                          | FBA Centennial "100"                                       | Figure 6-28, Figure 6-30                                       | Figure 6-31 | Figure 6-41 | Zone 3, Zone 2A [1][2] | All [5][7]            |                                                                                                                                                             |
| <b>FS 2002 Corp.</b> (FS 2002 Corporation.) [The New Piper Aircraft, Inc.]                       | PA-14                                                      | Figure 6-29, Figure 6-30                                       | Figure 6-31 | Figure 6-41 | Not Allowed            | All (except wing) [5] | [8]                                                                                                                                                         |
| <b>FS2003 Corp.</b> (FS 2003 Corporation) [The New Piper Aircraft, Inc.]                         | PA-12, PA-12S                                              | Not Allowed                                                    | Figure 6-31 | Not Allowed | Zone 3, Zone 2A [3]    | All (except wing) [5] | [8]                                                                                                                                                         |
| <b>Fuji</b> (Fuji Heavy Industries, Ltd)                                                         | FA-200-160, FA-200-180, FA-200-180AO                       | Figure 6-28, Figure 6-30                                       | Figure 6-31 | Figure 6-41 | Zone 3, Zone 2A [1][2] | All [5][7]            |                                                                                                                                                             |
| <b>Gomolzig Flugzeug- und Maschinenbau GmbH</b> (Gomolzig Flugzeug- und Maschinenbau GmbH) [FFA] | AS 202/15 "BRAVO", AS 202/18A "BRAVO", AS 202/18A4 "BRAVO" | Figure 6-28, Figure 6-30                                       | Figure 6-31 | Figure 6-41 | Zone 3, Zone 2A [1][2] | All [5][7]            |                                                                                                                                                             |
| <b>GROB Aircraft AG</b> (GROB Aircraft AG)                                                       | G115, G115A, G115B, G115C, G115C2, G115D, G115D2, G115EG   | Figure 6-28 or Figure 6-29 (refer to note column), Figure 6-30 | Figure 6-31 | Figure 6-41 | Zone 3 [4]             | Zone 3 [6]            | Aircraft may be IFR or limited to VFR per prior certification. For IFR aircraft, use Wing Figure 6-28. For VFR only aircraft, use Wing Figure 6-29. [8][10] |
| <b>Lancair</b> (Textron Aviation) [Columbia]                                                     | LC40-550FG, LC41-550FG, LC42-550FG                         | Figure 6-28, Figure 6-30                                       | Figure 6-31 | Figure 6-41 | Zone 3 [4]             | Zone 3 [6]            | [8]                                                                                                                                                         |



| Airplane Make (TCDS Holder) [common name or previous make]                                     | Airplane Model Designation                                                                                       | Lightning Zone Type (Ref. Appendix F)            |             |             | GTP 59 Location        | GMU 11 Location                                        | Notes                                                  |
|------------------------------------------------------------------------------------------------|------------------------------------------------------------------------------------------------------------------|--------------------------------------------------|-------------|-------------|------------------------|--------------------------------------------------------|--------------------------------------------------------|
|                                                                                                |                                                                                                                  | Wing                                             | Fuselage    | Empennage   |                        |                                                        |                                                        |
| <b>Legend Aviation &amp; Marine</b> (Legend Aviation & Marine LLC) [STOL Aircraft Corporation] | UC-1                                                                                                             | Figure 6-28, Figure 6-30                         | Figure 6-35 | Figure 6-41 | Zone 3, Zone 2A [1][2] | All [5][7]                                             |                                                        |
| <b>Liberty</b> (Liberty XL2 Holdings, LLC)                                                     | XL-2                                                                                                             | Figure 6-28, Figure 6-30                         | Not Allowed | Figure 6-41 | Zone 3 [4]             | Zone 3 [6]                                             | [8]                                                    |
| <b>Luscombe</b> (Good Earthkeeping Organization Inc)                                           | 8A, 8B, 8C, 8D, 8E, 8F, 8, T-8F                                                                                  | Figure 6-28, Figure 6-30                         | Figure 6-31 | Figure 6-41 | Zone 3, Zone 2A [1][2] | All [5][7]                                             |                                                        |
| <b>Helio</b> (Helio Aircraft, LLC)                                                             | H-250, H-295 (USAF U-10D), HT-295, H-391 (USAF YL-24), H-391B, H-395 (USAF L-28A or U-10B), H-395A, H-700, H-800 | Figure 6-28 (refer to notes column), Figure 6-30 | Figure 6-31 | Figure 6-41 | Zone 3, Zone 2A [1][2] | All [5][7]                                             | H-800 only: cannot mount GMU 11 or GTP 59 in the wing. |
| <b>Howard</b> (Howard Aircraft Foundation)                                                     | DGA-15P (Army UC-70, Navy GH-1, GH-2, GH-3, NH-1), DGA-15J (Army UC-70B), DGA-15W                                | Figure 6-28, Figure 6-30                         | Figure 6-31 | Figure 6-41 | Zone 3, Zone 2A [1][2] | Zone 3, Zone 2A (fuselage and emp.), Zone 3 (wing) [5] | [8]                                                    |
| <b>Interstate</b> (STOL Aviation LLC)                                                          | S-1B1, S-1B2                                                                                                     | Not Allowed                                      | Figure 6-31 | Figure 6-41 | Zone 3, Zone 2A [1][3] | All (except wing) [5]                                  | [8]                                                    |
| <b>Interceptor</b> (Interceptor Aircraft Inc) [Prop-Jets, Inc.; Meyers]                        | 200, 200A, 200B, 200C, 200D, 400                                                                                 | Figure 6-28, Figure 6-30                         | Figure 6-31 | Figure 6-41 | Zone 3, Zone 2A [1][2] | All [5][7]                                             |                                                        |
| <b>Lovaux Ltd</b> (FLS Aerospace (Lovaux) Ltd.)                                                | OA7 Optica Series 300                                                                                            | Figure 6-28, Figure 6-30                         | Not Allowed | Not Allowed | Zone 3, Zone 2A [1][2] | All (wing only) [5]                                    |                                                        |



| Airplane Make (TCDS Holder) [common name or previous make]              | Airplane Model Designation                                                                                                                                                                                                                                                                                                                                                                                                                                                                             | Lightning Zone Type (Ref. Appendix F) |             |             | GTP 59 Location        | GMU 11 Location                             | Notes |
|-------------------------------------------------------------------------|--------------------------------------------------------------------------------------------------------------------------------------------------------------------------------------------------------------------------------------------------------------------------------------------------------------------------------------------------------------------------------------------------------------------------------------------------------------------------------------------------------|---------------------------------------|-------------|-------------|------------------------|---------------------------------------------|-------|
|                                                                         |                                                                                                                                                                                                                                                                                                                                                                                                                                                                                                        | Wing                                  | Fuselage    | Empennage   |                        |                                             |       |
| <b>Maule</b> (Maule Aerospace Technology, Inc.)                         | Bee Dee M-4, M-4, M-4C, M-4S, M-4T, M-4-180C, M-4-180S, M-4-180T, M-4-180V, M-4-210, M-4-210C, M-4-210S, M-4-210T, M-4-220, M-4-220C, M-4-220S, M-4-220T, M-5-180C, M-5-200, M-5-210C, M-5-210TC, M-5-220C, M-5-235C, M-6-180, M-6-235, M-7-235, MX-7-235, MX-7-180, MX-7-420, MXT-7-180, MT-7-235, M-8-235, MX-7-160, MXT-7-160, MX-7-180A, MXT-7-180A, MX-7-180B, M-7-235B, M-7-235A, M-7-235C, MX-7-180C, M-7-260, MT-7-260, M-7-260C, M-7-420AC, MX-7-160C, MX-7-180AC, M-7-420A, MT-7-420 M-9-235 | Figure 6-28, Figure 6-30              | Figure 6-31 | Figure 6-41 | Zone 3, Zone 2A [1][3] | All, (fuselage and emp.), Zone 3 (wing) [5] | [8]   |
| <b>MICCO Aircraft Co., Inc.</b> (MICCO Aircraft Company, Inc.) [Meyers] | MAC-125C, MAC-145, MAC-145A, MAC-145B                                                                                                                                                                                                                                                                                                                                                                                                                                                                  | Figure 6-28, Figure 6-30              | Figure 6-31 | Figure 6-41 | Zone 3, Zone 2A [1][2] | All [5][7]                                  |       |



| Airplane Make (TCDS Holder) [common name or previous make]                                                                                                 | Airplane Model Designation                                                                          | Lightning Zone Type (Ref. Appendix F) |             |             | GTP 59 Location        | GMU 11 Location | Notes |
|------------------------------------------------------------------------------------------------------------------------------------------------------------|-----------------------------------------------------------------------------------------------------|---------------------------------------|-------------|-------------|------------------------|-----------------|-------|
|                                                                                                                                                            |                                                                                                     | Wing                                  | Fuselage    | Empennage   |                        |                 |       |
| <b>Mooney</b> (Mooney International Corporation) [Mooney Aviation Company, Inc.; Mooney Airplane Co.; Mooney Aircraft Corporation; Aerostar Aircraft Corp] | M20, M20A, M20B, M20C, M20D, M20E, M20F, M20G, M20J, M20K, M20L, M20M, M20R, M20S                   | Figure 6-28, Figure 6-30              | Figure 6-31 | Figure 6-41 | Zone 3, Zone 2A [1][2] | All [5][7]      |       |
| <b>Mooney</b> (Mooney Aircraft Corporation)                                                                                                                | M22                                                                                                 | Figure 6-28, Figure 6-30              | Figure 6-31 | Figure 6-41 | Zone 3, Zone 2A [1][2] | All [5][7]      |       |
| <b>Nardi</b> (Nardi S.A.) [Siai Marchetti]                                                                                                                 | FN-333                                                                                              | Figure 6-28, Figure 6-30              | Figure 6-33 | Not Allowed | Zone 3, Zone 2A [1][2] | All [5][7]      |       |
| <b>Navion</b> (Sierra Hotel Aero, Inc.)                                                                                                                    | Navion (L-17A), Navion A (L-17B, L-17C), Navion B, Navion D, Navion E, Navion F, Navion G, Navion H | Figure 6-28, Figure 6-30              | Figure 6-31 | Figure 6-41 | Zone 3, Zone 2A [1][2] | All [5][7]      |       |
| <b>Piaggio</b> (Piaggio & C.)                                                                                                                              | P.136-L, P.136-L1                                                                                   | Figure 6-28, Figure 6-30              | Figure 6-36 | Figure 6-41 | Zone 3, Zone 2A [1][2] | All [5][7]      |       |
| <b>Piper Aircraft, Inc.</b> (Piper Aircraft, Inc.)                                                                                                         | PA-16, PA-16S                                                                                       | Figure 6-28, Figure 6-30              | Figure 6-31 | Not Allowed | Zone 3, Zone 2A [1][3] | All [5]         |       |



| Airplane Make (TCDS Holder) [common name or previous make] | Airplane Model Designation                                                                                                                                                                                                                                       | Lightning Zone Type (Ref. Appendix F) |             |             | GTP 59 Location              | GMU 11 Location                         | Notes |
|------------------------------------------------------------|------------------------------------------------------------------------------------------------------------------------------------------------------------------------------------------------------------------------------------------------------------------|---------------------------------------|-------------|-------------|------------------------------|-----------------------------------------|-------|
|                                                            |                                                                                                                                                                                                                                                                  | Wing                                  | Fuselage    | Empennage   |                              |                                         |       |
| <b>Piper Aircraft, Inc.</b><br>(Piper Aircraft, Inc.)      | PA-18, PA-18 “105”, PA-18 “125” (Army L-21A), PA-18S, PA-18S “105”, PA-18S “125”, PA-18AS “125”, PA-18 “135” (Army L-21B), PA-18A, PA-18A “135”, PA-18S “135”, PA-18AS “135”, PA-18 “150”, PA-18A “150”, PA-18S “150”, PA-18AS “150”, PA-19 (Army L-18C), PA-19S | Figure 6-28,<br>Figure 6-30           | Figure 6-31 | Not Allowed | Zone 3,<br>Zone 2A<br>[1][3] | All (fuselage),<br>Zone 3 (wing)<br>[5] | [8]   |
| <b>Piper Aircraft, Inc.</b><br>(Piper Aircraft, Inc.)      | PA-20, PA-20S, PA-20 “115”, PA-20S “115” PA-20 “135”, PA-20S “135”                                                                                                                                                                                               | Figure 6-28,<br>Figure 6-30           | Figure 6-31 | Not Allowed | Zone 3,<br>Zone 2A<br>[1][3] | All (fuselage),<br>Zone 3 (wing) [5]    | [8]   |
| <b>Piper Aircraft, Inc.</b><br>(Piper Aircraft, Inc.)      | PA-22, PA-22-108, PA-22-135, PA-22S-135, PA-22-150, PA-22S-150, PA-22-160, PA-22S-160                                                                                                                                                                            | Figure 6-28,<br>Figure 6-30           | Figure 6-31 | Not Allowed | Zone 3,<br>Zone 2A<br>[1][3] | All (fuselage),<br>Zone 3 (wing) [5]    | [8]   |
| <b>Piper Aircraft, Inc.</b><br>(Piper Aircraft, Inc.)      | PA-23, PA-23-160, PA-23-235, PA-23-250, PA-E23-250                                                                                                                                                                                                               | Figure 6-28,<br>Figure 6-30           | Figure 6-35 | Figure 6-41 | Zone 3,<br>Zone 2A<br>[1][2] | All<br>[5][7]                           |       |
| <b>Piper Aircraft, Inc.</b><br>(Piper Aircraft, Inc.)      | PA-24, PA-24-250, PA-24-260, PA-24-400                                                                                                                                                                                                                           | Figure 6-28,<br>Figure 6-30           | Figure 6-35 | Figure 6-41 | Zone 3,<br>Zone 2A<br>[1][2] | All<br>[5][7]                           |       |



| Airplane Make (TCDS Holder) [common name or previous make] | Airplane Model Designation                                                                                                                                                                                        | Lightning Zone Type (Ref. Appendix F) |             |             | GTP 59 Location              | GMU 11 Location | Notes |
|------------------------------------------------------------|-------------------------------------------------------------------------------------------------------------------------------------------------------------------------------------------------------------------|---------------------------------------|-------------|-------------|------------------------------|-----------------|-------|
|                                                            |                                                                                                                                                                                                                   | Wing                                  | Fuselage    | Empennage   |                              |                 |       |
| <b>Piper Aircraft, Inc.</b><br>(Piper Aircraft, Inc.)      | PA-28-140, PA-28-150, PA-28-151, PA-28-160, PA-28-161, PA-28-180, PA-28-235, PA-28S-160, PA-28R-180, PA-28S-180, PA-28-181, PA-28R-200, PA-28R-201, PA-28R-201T, PA-28RT-201, PA-28RT-201T, PA-28-201T, PA-28-236 | Figure 6-28,<br>Figure 6-30           | Figure 6-31 | Figure 6-41 | Zone 3,<br>Zone 2A<br>[1][2] | All<br>[5][7]   |       |
| <b>Piper Aircraft, Inc.</b><br>(Piper Aircraft, Inc.)      | PA-38-112                                                                                                                                                                                                         | Figure 6-28,<br>Figure 6-30           | Figure 6-31 | Figure 6-41 | Zone 3,<br>Zone 2A<br>[1][2] | All<br>[5][7]   |       |
| <b>Piper Aircraft, Inc.</b><br>(Piper Aircraft, Inc.)      | PA-44-180, PA-44-180T                                                                                                                                                                                             | Figure 6-28,<br>Figure 6-30           | Figure 6-35 | Figure 6-41 | Zone 3,<br>Zone 2A<br>[1][2] | All<br>[5][7]   |       |
| <b>Piper Aircraft, Inc.</b><br>(Piper Aircraft, Inc.)      | PA-30, PA-39, PA-40                                                                                                                                                                                               | Figure 6-28,<br>Figure 6-30           | Figure 6-35 | Figure 6-41 | Zone 3,<br>Zone 2A<br>[1][2] | All<br>[5][7]   |       |
| <b>Piper Aircraft, Inc.</b><br>(Piper Aircraft, Inc.)      | PA-32-260, PA-32-300, PA-32S-300, PA-32R-300, PA-32RT-300, PA-32RT-300T, PA-32R-301(SP), PA-32R-301(HP), PA-32R-301T, PA-32-301, PA-32-301T, PA-32-301FT, PA32-301XTC                                             | Figure 6-28,<br>Figure 6-30           | Figure 6-31 | Figure 6-41 | Zone 3,<br>Zone 2A<br>[1][2] | All<br>[5][7]   |       |



| Airplane Make (TCDS Holder) [common name or previous make]                                          | Airplane Model Designation                                                                                                                      | Lightning Zone Type (Ref. Appendix F) |             |             | GTP 59 Location              | GMU 11 Location                               | Notes                                    |
|-----------------------------------------------------------------------------------------------------|-------------------------------------------------------------------------------------------------------------------------------------------------|---------------------------------------|-------------|-------------|------------------------------|-----------------------------------------------|------------------------------------------|
|                                                                                                     |                                                                                                                                                 | Wing                                  | Fuselage    | Empennage   |                              |                                               |                                          |
| <b>Piper Aircraft, Inc.</b><br>(Piper Aircraft, Inc.)                                               | PA-34-200, PA-34-200T, PA-34-220T                                                                                                               | Figure 6-28,<br>Figure 6-30           | Figure 6-35 | Figure 6-41 | Zone 3,<br>Zone 2A<br>[1][2] | All<br>[5][7]                                 |                                          |
| <b>Polskie Zakłady Lotnicze Spolka zo.o</b><br>(Polskie Zakłady Lotnicze Spolka zo.o) [PZL MIELEC]  | PZL M26 01                                                                                                                                      | Figure 6-28,<br>Figure 6-30           | Figure 6-31 | Figure 6-41 | Zone 3,<br>Zone 2A<br>[1][2] | All<br>[5][7]                                 |                                          |
| <b>Revo, Inc.</b> (Revo, Incorporated) [Lake]                                                       | Colonial C-1,<br>Colonial C-2, Lake LA Series, Lake Model 250                                                                                   | Figure 6-28,<br>Figure 6-30           | Figure 6-34 | Figure 6-41 | Zone 3,<br>Zone 2A<br>[1][2] | All<br>[5][7]                                 |                                          |
| <b>SOCATA Morane Saulnier Rallye</b><br>(SOCATA) [SOCATA - Groupe Aerospatiale]                     | Rallye 100S, Rallye 150ST, Rallye 150T, Rallye 235E, Rallye 235C, MS 880B, MS 885, MS 894A, MS 893A, MS 892A-150, MS 892E-150, MS 893E, MS 894E | Figure 6-28,<br>Figure 6-30           | Figure 6-31 | Figure 6-41 | Zone 3,<br>Zone 2A<br>[1][2] | All<br>[5][7]                                 |                                          |
| <b>SOCATA</b> (SOCATA) [SOCATA - Groupe Aerospatiale]                                               | TB 9, TB 10, TB 20, TB 21, TB 200                                                                                                               | Figure 6-28,<br>Figure 6-30           | Figure 6-31 | Figure 6-41 | Zone 3,<br>Zone 2A<br>[1][2] | All<br>[5][7]                                 |                                          |
| <b>Spartan Aircraft Company</b>                                                                     | Spartan 7W                                                                                                                                      | Figure 6-28,<br>Figure 6-30           | Figure 6-31 | Figure 6-41 | Zone 3,<br>Zone 2A<br>[1][2] | All<br>[5][7]                                 |                                          |
| <b>SST FLUGTECHNIK GmbH</b> (SST FLUGTECHNIK GmbH) [Extra Flugzeugproduktions- und Vertriebs- GmbH] | EA-400, EA-400-500                                                                                                                              | Figure 6-28,<br>Figure 6-30           | Figure 6-31 | Figure 6-41 | Zone 3,<br>Zone 2A<br>[4]    | All (fuselage and emp.),<br>Zone 3 (wing) [6] | G5 is allowed to be HSI only.<br>[8][10] |



| Airplane Make (TCDS Holder) [common name or previous make]           | Airplane Model Designation                                                     | Lightning Zone Type (Ref. Appendix F) |                          |             | GTP 59 Location        | GMU 11 Location                            | Notes |
|----------------------------------------------------------------------|--------------------------------------------------------------------------------|---------------------------------------|--------------------------|-------------|------------------------|--------------------------------------------|-------|
|                                                                      |                                                                                | Wing                                  | Fuselage                 | Empennage   |                        |                                            |       |
| <b>Stinson</b> (Consolidated Vultee Aircraft Corporation)            | V-77 (Army AT-19)                                                              | Figure 6-28, Figure 6-30              | Figure 6-31              | Figure 6-41 | Zone 3, Zone 2A [1][3] | All (fuselage and emp.), Zone 3 (wing) [5] | [8]   |
| <b>STOL</b> (Sky Enterprises, Inc.) [Republic Sea-Bee]               | RC-3                                                                           | Figure 6-28, Figure 6-30              | Figure 6-33              | Figure 6-41 | Zone 3, Zone 2A [1][2] | All [5][7]                                 |       |
| <b>Swift</b> (Swift Museum Foundation Inc.) [Globe Aircraft Company] | GC-1A, GC-1B                                                                   | Figure 6-28, Figure 6-30              | Figure 6-31              | Figure 6-41 | Zone 3, Zone 2A [1][2] | All [5][7]                                 |       |
| <b>Symphony</b> (Symphony Aircraft Industries, Inc)                  | OMF-100-160, SA 160                                                            | Figure 6-28, Figure 6-30              | Figure 6-31              | Figure 6-41 | Zone 3, Zone 2A [1][2] | All (fuselage and emp.), Zone 3 (wing) [5] | [8]   |
| <b>Textron Aviation</b> (Textron Aviation Inc.) [Beechcraft]         | D17S (Army UC-43, UC-43B, Navy GB-1, GB-2), SD17S                              | Figure 6-28, Figure 6-30              | Figure 6-31, Figure 6-40 | Figure 6-41 | Zone 3, Zone 2A [1][3] | All (fuselage and emp.), Zone 3 (wing) [5] | [8]   |
| <b>Textron Aviation</b> (Textron Aviation Inc.) [Beechcraft]         | G17S                                                                           | Figure 6-28, Figure 6-30              | Figure 6-31, Figure 6-40 | Figure 6-41 | Zone 3, Zone 2A [1][3] | All (fuselage and emp.), Zone 3 (wing) [5] | [8]   |
| <b>Textron Aviation</b> (Textron Aviation Inc.) [Beechcraft]         | 19A, B19, M19A, 23, A23, A23A, A23-19, A23-24, B23, C23, A24, A24R, B24R, C24R | Figure 6-28, Figure 6-30              | Figure 6-31              | Figure 6-41 | Zone 3, Zone 2A [1][2] | All [5][7]                                 |       |





| Airplane Make (TCDS Holder) [common name or previous make]         | Airplane Model Designation                                                                                                                               | Lightning Zone Type (Ref. Appendix F) |             |                                         | GTP 59 Location              | GMU 11 Location | Notes                                                                  |
|--------------------------------------------------------------------|----------------------------------------------------------------------------------------------------------------------------------------------------------|---------------------------------------|-------------|-----------------------------------------|------------------------------|-----------------|------------------------------------------------------------------------|
|                                                                    |                                                                                                                                                          | Wing                                  | Fuselage    | Empennage                               |                              |                 |                                                                        |
| <b>Textron Aviation</b><br>(Textron Aviation Inc.)<br>[Beechcraft] | 35-33, 35-A33, 35-B33, 35-C33, 35-C33A, E33, E33A, E33C, F33, F33A, F33C, G33, H35, J35, K35, M35, N35, P35, S35, V35, V35A, V35B, 36, A36, A36TC, B36TC | Figure 6-28,<br>Figure 6-30           | Figure 6-31 | Figure 6-41,<br>Figure 6-42<br>(V-tail) | Zone 3,<br>Zone 2A<br>[1][2] | All<br>[5][7]   | It is highly discouraged to mount any equipment in a V-tail empennage. |
| <b>Textron Aviation</b><br>(Textron Aviation Inc.)<br>[Beechcraft] | 35, A35, B35, C35, D35, E35, F35, G35                                                                                                                    | Figure 6-28,<br>Figure 6-30           | Figure 6-31 | Figure 6-42                             | Zone 3,<br>Zone 2A<br>[1][2] | All<br>[5][7]   | It is highly discouraged to mount any equipment in the empennage.      |
| <b>Textron Aviation</b><br>(Textron Aviation Inc.)<br>[Beechcraft] | 45 (YT-34), A45 (T-34A, B-45), D45 (T-34B)                                                                                                               | Figure 6-28,<br>Figure 6-30           | Figure 6-31 | Figure 6-41                             | Zone 3,<br>Zone 2A<br>[1][2] | All<br>[5][7]   |                                                                        |
| <b>Textron Aviation</b><br>(Textron Aviation Inc.)<br>[Beechcraft] | 50, B50, C50                                                                                                                                             | Figure 6-28,<br>Figure 6-30           | Figure 6-35 | Figure 6-41                             | Zone 3,<br>Zone 2A<br>[1][2] | All<br>[5][7]   |                                                                        |
| <b>Textron Aviation</b><br>(Textron Aviation Inc.)<br>[Beechcraft] | D55, D55A, E55, E55A, 56TC, A56TC, 58, 58A, 95, B95, B95A, D95A, E95, 95-55, 95-A55, 95-B55, 95-B55A, 95-B55B (T-42), 95-C55, 95-C55A                    | Figure 6-28,<br>Figure 6-30           | Figure 6-35 | Figure 6-41                             | Zone 3,<br>Zone 2A<br>[1][2] | All<br>[5][7]   |                                                                        |
| <b>Textron Aviation</b><br>(Textron Aviation Inc.)<br>[Beechcraft] | 76                                                                                                                                                       | Figure 6-28,<br>Figure 6-30           | Figure 6-35 | Figure 6-41                             | Zone 3,<br>Zone 2A<br>[1][2] | All<br>[5][7]   |                                                                        |



| Airplane Make (TCDS Holder) [common name or previous make]                           | Airplane Model Designation                                                                                                  | Lightning Zone Type (Ref. Appendix F) |             |             | GTP 59 Location              | GMU 11 Location | Notes |
|--------------------------------------------------------------------------------------|-----------------------------------------------------------------------------------------------------------------------------|---------------------------------------|-------------|-------------|------------------------------|-----------------|-------|
|                                                                                      |                                                                                                                             | Wing                                  | Fuselage    | Empennage   |                              |                 |       |
| <b>Textron Aviation</b><br>(Textron Aviation Inc.)<br>[Beechcraft]                   | 77                                                                                                                          | Figure 6-28,<br>Figure 6-30           | Figure 6-31 | Figure 6-41 | Zone 3,<br>Zone 2A<br>[1][2] | All<br>[5][7]   |       |
| <b>Textron Aviation Inc.</b><br>(Textron Aviation Inc.)<br>[Cessna Aircraft Company] | 140A                                                                                                                        | Figure 6-28,<br>Figure 6-30           | Figure 6-31 | Figure 6-41 | Zone 3,<br>Zone 2A<br>[1][2] | All<br>[5][7]   |       |
| <b>Textron Aviation Inc.</b><br>(Textron Aviation Inc.)<br>[Cessna Aircraft Company] | 120, 140                                                                                                                    | Figure 6-28,<br>Figure 6-30           | Figure 6-31 | Figure 6-41 | Zone 3,<br>Zone 2A<br>[1][2] | All<br>[5][7]   |       |
| <b>Textron Aviation Inc.</b><br>(Textron Aviation Inc.)<br>[Cessna Aircraft Company] | 150, 150A, 150B,<br>150C, 150D, 150E,<br>150F, 150G, 150H,<br>150J, 150K, A150K,<br>150L, A150L, 150M,<br>A150M, 152, A152  | Figure 6-28,<br>Figure 6-30           | Figure 6-31 | Figure 6-41 | Zone 3,<br>Zone 2A<br>[1][2] | All<br>[5][7]   |       |
| <b>Textron Aviation Inc.</b><br>(Textron Aviation Inc.)<br>[Cessna Aircraft Company] | F150F, F150G,<br>F150H, F150J,<br>F150K, F150L,<br>F150M, F152,<br>FA150K, FA150L,<br>FA150M, FA152,<br>FRA150L,<br>FRA150M | Figure 6-28,<br>Figure 6-30           | Figure 6-31 | Figure 6-41 | Zone 3,<br>Zone 2A<br>[1][2] | All<br>[5][7]   |       |
| <b>Textron Aviation Inc.</b><br>(Textron Aviation Inc.)<br>[Cessna Aircraft Company] | 170, 170A, 170B                                                                                                             | Figure 6-28,<br>Figure 6-30           | Figure 6-31 | Figure 6-41 | Zone 3,<br>Zone 2A<br>[1][2] | All<br>[5][7]   |       |



| Airplane Make (TCDS Holder) [common name or previous make]                           | Airplane Model Designation                                                                                                                                | Lightning Zone Type (Ref. Appendix F) |             |             | GTP 59 Location              | GMU 11 Location | Notes |
|--------------------------------------------------------------------------------------|-----------------------------------------------------------------------------------------------------------------------------------------------------------|---------------------------------------|-------------|-------------|------------------------------|-----------------|-------|
|                                                                                      |                                                                                                                                                           | Wing                                  | Fuselage    | Empennage   |                              |                 |       |
| <b>Textron Aviation Inc.</b><br>(Textron Aviation Inc.)<br>[Cessna Aircraft Company] | 172, 172A, 172B, 172C, 172D, 172E, 172F (USAF T-41A), 172G, 172H (USAF T-41A), 172I, 172K, 172L, 172M, 172N, 172P, 172Q, 172R, 172S                       | Figure 6-28,<br>Figure 6-30           | Figure 6-31 | Figure 6-41 | Zone 3,<br>Zone 2A<br>[1][2] | All<br>[5][7]   |       |
| <b>Textron Aviation Inc.</b><br>(Textron Aviation Inc.)<br>[Cessna Aircraft Company] | F172D, F172E, F172F, F172G, F172H, F172K, F172L, F172M, F172N, F172P, FP172D                                                                              | Figure 6-28,<br>Figure 6-30           | Figure 6-31 | Figure 6-41 | Zone 3,<br>Zone 2A<br>[1][2] | All<br>[5][7]   |       |
| <b>Textron Aviation Inc.</b><br>(Textron Aviation Inc.)<br>[Cessna Aircraft Company] | FR172E, FR172F, FR172G, FR172H, FR172J, FR172K                                                                                                            | Figure 6-28,<br>Figure 6-30           | Figure 6-31 | Figure 6-41 | Zone 3,<br>Zone 2A<br>[1][2] | All<br>[5][7]   |       |
| <b>Textron Aviation Inc.</b><br>(Textron Aviation Inc.)<br>[Cessna Aircraft Company] | 175, 175A, 175B, 175C, P172D, R172E (USAF T-41B), (USAF T-41C or D), R172F (USAF T-41D), R172G (USAF T-41C or D), R172H (USAF T-41D), R172J, 172RG, R172K | Figure 6-28,<br>Figure 6-30           | Figure 6-31 | Figure 6-41 | Zone 3,<br>Zone 2A<br>[1][2] | All<br>[5][7]   |       |
| <b>Textron Aviation Inc.</b><br>(Textron Aviation Inc.)<br>[Cessna Aircraft Company] | 177, 177A, 177B                                                                                                                                           | Figure 6-28,<br>Figure 6-30           | Figure 6-31 | Figure 6-41 | Zone 3,<br>Zone 2A<br>[1][2] | All<br>[5][7]   |       |



| Airplane Make (TCDS Holder) [common name or previous make]                           | Airplane Model Designation                                                                                                                                     | Lightning Zone Type (Ref. Appendix F) |             |             | GTP 59 Location              | GMU 11 Location | Notes |
|--------------------------------------------------------------------------------------|----------------------------------------------------------------------------------------------------------------------------------------------------------------|---------------------------------------|-------------|-------------|------------------------------|-----------------|-------|
|                                                                                      |                                                                                                                                                                | Wing                                  | Fuselage    | Empennage   |                              |                 |       |
| <b>Textron Aviation Inc.</b><br>(Textron Aviation Inc.)<br>[Cessna Aircraft Company] | 177RG                                                                                                                                                          | Figure 6-28,<br>Figure 6-30           | Figure 6-31 | Figure 6-41 | Zone 3,<br>Zone 2A<br>[1][2] | All<br>[5][7]   |       |
| <b>Textron Aviation Inc.</b><br>(Textron Aviation Inc.)<br>[Cessna Aircraft Company] | F177RG                                                                                                                                                         | Figure 6-28,<br>Figure 6-30           | Figure 6-31 | Figure 6-41 | Zone 3,<br>Zone 2A<br>[1][2] | All<br>[5][7]   |       |
| <b>Textron Aviation Inc.</b><br>(Textron Aviation Inc.)<br>[Cessna Aircraft Company] | 180, 180A, 180B,<br>180C, 180D, 180E,<br>180F, 180G, 180H,<br>180J, 180K                                                                                       | Figure 6-28,<br>Figure 6-30           | Figure 6-31 | Figure 6-41 | Zone 3,<br>Zone 2A<br>[1][2] | All<br>[5][7]   |       |
| <b>Textron Aviation Inc.</b><br>(Textron Aviation Inc.)<br>[Cessna Aircraft Company] | 182, 182A, 182B,<br>182C, 182D, 182E,<br>182F, 182G, 182H,<br>182J, 182K, 182L,<br>182M, 182N, 182P,<br>182Q, 182R, 182S,<br>182T, R182, T182,<br>TR182, T182T | Figure 6-28,<br>Figure 6-30           | Figure 6-31 | Figure 6-41 | Zone 3,<br>Zone 2A<br>[1][2] | All<br>[5][7]   |       |
| <b>Textron Aviation Inc.</b><br>(Textron Aviation Inc.)<br>[Cessna Aircraft Company] | F182P, F182Q,<br>FR182                                                                                                                                         | Figure 6-28,<br>Figure 6-30           | Figure 6-31 | Figure 6-41 | Zone 3,<br>Zone 2A<br>[1][2] | All<br>[5][7]   |       |
| <b>Textron Aviation Inc.</b><br>(Textron Aviation Inc.)<br>[Cessna Aircraft Company] | 185, 185A, 185B,<br>185C, 185D, 185E,<br>A185E, A185F                                                                                                          | Figure 6-28,<br>Figure 6-30           | Figure 6-31 | Figure 6-41 | Zone 3,<br>Zone 2A<br>[1][2] | All<br>[5][7]   |       |
| <b>Textron Aviation Inc.</b><br>(Textron Aviation Inc.)<br>[Cessna Aircraft Company] | 190, 195 (LC-<br>126A,B,C), 195A,<br>195B                                                                                                                      | Figure 6-28,<br>Figure 6-30           | Figure 6-31 | Figure 6-41 | Zone 3,<br>Zone 2A<br>[1][2] | All<br>[5][7]   |       |



| Airplane Make (TCDS Holder) [common name or previous make]                           | Airplane Model Designation                                                                                                                                                                                       | Lightning Zone Type (Ref. Appendix F) |             |             | GTP 59 Location              | GMU 11 Location | Notes |
|--------------------------------------------------------------------------------------|------------------------------------------------------------------------------------------------------------------------------------------------------------------------------------------------------------------|---------------------------------------|-------------|-------------|------------------------------|-----------------|-------|
|                                                                                      |                                                                                                                                                                                                                  | Wing                                  | Fuselage    | Empennage   |                              |                 |       |
| <b>Textron Aviation Inc.</b><br>(Textron Aviation Inc.)<br>[Cessna Aircraft Company] | 206, P206, P206A, P206B, P206C, P206D, P206E, TP206A, TP206B, TP206C, TP206D, TP206E, U206, U206A, U206B, U206C, U206D, U206E, U206F, U206G, TU206A, TU206B, TU206C, TU206D, TU206E, TU206F, TU206G, 206H, T206H | Figure 6-28,<br>Figure 6-30           | Figure 6-31 | Figure 6-41 | Zone 3,<br>Zone 2A<br>[1][2] | All<br>[5][7]   |       |
| <b>Textron Aviation Inc.</b><br>(Textron Aviation Inc.)<br>[Cessna Aircraft Company] | 210, 210A, 210B, 210C, 210D, 210E, 210F, T210F, 210G, T210G, 210H, T210H, 210J, T210J, 210K, T210K, 210L, T210L, 210M, T210M, 210N, T210N, 210R, T210R, 210-5 (205), 210-5A (205A), P210N, P210R                 | Figure 6-28,<br>Figure 6-30           | Figure 6-31 | Figure 6-41 | Zone 3,<br>Zone 2A<br>[1][2] | All<br>[5][7]   |       |
| <b>Textron Aviation Inc.</b><br>(Textron Aviation Inc.)<br>[Cessna Aircraft Company] | T303                                                                                                                                                                                                             | Figure 6-28,<br>Figure 6-30           | Figure 6-35 | Figure 6-41 | Zone 3,<br>Zone 2A<br>[1][2] | All<br>[5][7]   |       |



| Airplane Make (TCDS Holder) [common name or previous make]                           | Airplane Model Designation                                                                                                                                             | Lightning Zone Type (Ref. Appendix F) |             |             | GTP 59 Location              | GMU 11 Location             | Notes |
|--------------------------------------------------------------------------------------|------------------------------------------------------------------------------------------------------------------------------------------------------------------------|---------------------------------------|-------------|-------------|------------------------------|-----------------------------|-------|
|                                                                                      |                                                                                                                                                                        | Wing                                  | Fuselage    | Empennage   |                              |                             |       |
| <b>Textron Aviation Inc.</b><br>(Textron Aviation Inc.)<br>[Cessna Aircraft Company] | 310, 310A (USAF U-3A), 310B, 310C, 310D, 310E (USAF U-3B), 310F, 310G, 310H, E310H, 310I, 310J, 310J-1, E310J, 310K, 310L, 310N, 310P, T310P, 310Q, T310Q, 310R, T310R | Figure 6-28,<br>Figure 6-30           | Figure 6-35 | Figure 6-41 | Zone 3,<br>Zone 2A<br>[1][2] | All<br>[5][7]               |       |
| <b>Textron Aviation Inc.</b><br>(Textron Aviation Inc.)<br>[Cessna Aircraft Company] | 320, 320A, 320B, 320C, 320D, 320E, 320F, 320-1, 335, 340, 340A                                                                                                         | Figure 6-28,<br>Figure 6-30           | Figure 6-35 | Figure 6-41 | Zone 3,<br>Zone 2A<br>[1][2] | All<br>[5][7]               |       |
| <b>Textron Aviation Inc.</b><br>(Textron Aviation Inc.)<br>[Cessna Aircraft Company] | 336                                                                                                                                                                    | Figure 6-28,<br>Figure 6-30           | Figure 6-37 | Figure 6-43 | Zone 3,<br>Zone 2A<br>[1][2] | All (except emp.)<br>[5][7] |       |
| <b>Textron Aviation Inc.</b><br>(Textron Aviation Inc.)<br>[Cessna Aircraft Company] | 337, 337A (USAF 02B), 337B, T337B, 337C, 337E, T337E, T337C, 337D, T337D, 337F, T337F, 337G, T337G, 337H, P337H, T337H, T337H-SP                                       | Figure 6-28,<br>Figure 6-30           | Figure 6-37 | Figure 6-43 | Zone 3,<br>Zone 2A<br>[1][2] | All (except emp.)<br>[5][7] |       |
| <b>Textron Aviation Inc.</b><br>(Textron Aviation Inc.)<br>[Cessna Aircraft Company] | F337E, FT337E, F337F, FT337F, F337G, FT337GP, F337H, FT337HP                                                                                                           | Figure 6-28,<br>Figure 6-30           | Figure 6-37 | Not Allowed | Zone 3,<br>Zone 2A<br>[1][2] | All<br>[5][7]               |       |
| <b>Thrush Aircraft Inc.</b><br>(Thrust Aircraft Inc.)<br>[Snow, Rockwell, Ayres]     | 600 S-2D, S2R, S2R-T34, S2R-T15, S2R-T11, S2R-R3S, S2R-R1340                                                                                                           | Figure 6-29,<br>Figure 6-30           | Figure 6-31 | Figure 6-41 | Zone 3,<br>Zone 2A<br>[1][2] | All<br>[5][7]               |       |



| Airplane Make (TCDS Holder) [common name or previous make]                    | Airplane Model Designation                                   | Lightning Zone Type (Ref. Appendix F) |             |             | GTP 59 Location        | GMU 11 Location                            | Notes |
|-------------------------------------------------------------------------------|--------------------------------------------------------------|---------------------------------------|-------------|-------------|------------------------|--------------------------------------------|-------|
|                                                                               |                                                              | Wing                                  | Fuselage    | Empennage   |                        |                                            |       |
| <b>Thrush Aircraft Inc.</b> (Thrust Aircraft Inc.) [Snow, Rockwell, Ayres]    | S2R-R1820, S2R-T65, S2R-T45, S2R-G6, S2R-G10, S2R-G5, S2R-G1 | Figure 6-29, Figure 6-30              | Figure 6-31 | Figure 6-41 | Zone 3, Zone 2A [1][2] | All [5][7]                                 |       |
| <b>Topcub Aircraft Inc.</b> (Topcub Aircraft Inc.) [Cub Crafters]             | CC18-180, CC18-180A                                          | Figure 6-29, Figure 6-30              | Figure 6-31 | Figure 6-41 | Zone 3, Zone 2A [1][3] | All [5][7]                                 |       |
| <b>Trident</b> (Viking Air, Ltd.)                                             | TR-1                                                         | Figure 6-28, Figure 6-30              | Figure 6-33 | Figure 6-41 | Zone 3, Zone 2A [1][2] | All [5][7]                                 |       |
| <b>True Flight Holdings LLC</b> (True Flight Holdings LLC) [American General] | AA-1, AA-1A, AA-1B, AA-1C                                    | Figure 6-28, Figure 6-30              | Figure 6-31 | Figure 6-41 | Zone 3, Zone 2A [1][2] | All [5][7]                                 |       |
| <b>True Flight Holdings LLC</b> (True Flight Holdings LLC) [American General] | AA-5, AA-5A, AA-5B, AG-5B                                    | Figure 6-28, Figure 6-30              | Figure 6-31 | Figure 6-41 | Zone 3, Zone 2A [1][2] | All [5][7]                                 |       |
| <b>Univair</b> (Univair Aircraft Corporation)                                 | 415-D, 415-E, 415-G, F-1, F-1A, A-2, A2-A, M10               | Figure 6-28, Figure 6-30              | Figure 6-31 | Figure 6-43 | Zone 3, Zone 2A [1][2] | All [5][7]                                 |       |
| <b>Univair</b> (Univair Corporation) [Stinson]                                | 108, 108-1, 108-2, 108-3, 108-5                              | Figure 6-28, Figure 6-30              | Figure 6-31 | Figure 6-41 | Zone 3, Zone 2A [1][3] | All (fuselage and emp.), Zone 3 (wing) [5] | [8]   |
| <b>Univair</b> (Univair Corporation) [Stinson]                                | 415-C, 415-CD                                                | Figure 6-28, Figure 6-30              | Figure 6-31 | Figure 6-43 | Zone 3, Zone 2A [1][2] | All [5][7]                                 |       |
| <b>Varga</b> (Augustair, Inc)                                                 | 2150, 2150A, 2180                                            | Figure 6-28, Figure 6-30              | Figure 6-31 | Figure 6-41 | Zone 3, Zone 2A [1][2] | All [5][7]                                 |       |



| Airplane Make (TCDS Holder) [common name or previous make]                                                                                                                                                   | Airplane Model Designation | Lightning Zone Type (Ref. Appendix F) |                             |             | GTP 59 Location              | GMU 11 Location                               | Notes |
|--------------------------------------------------------------------------------------------------------------------------------------------------------------------------------------------------------------|----------------------------|---------------------------------------|-----------------------------|-------------|------------------------------|-----------------------------------------------|-------|
|                                                                                                                                                                                                              |                            | Wing                                  | Fuselage                    | Empennage   |                              |                                               |       |
| <b>Vulcanair S.p.A</b><br>(Vulcanair S.p.A)<br>[Partenavia]                                                                                                                                                  | V1.0                       | Figure 6-28,<br>Figure 6-30           | Figure 6-31,<br>Figure 6-40 | Figure 6-41 | Zone 3,<br>Zone 2A<br>[1][3] | All<br>[5][7]                                 |       |
| <b>Vulcanair S.p.A</b><br>(Vulcanair S.p.A)<br>[Partenavia]                                                                                                                                                  | P.68, P.68B                | Figure 6-28,<br>Figure 6-30           | Figure 6-35                 | Figure 6-41 | Zone 3,<br>Zone 2A<br>[1][2] | All<br>[5][7]                                 |       |
| <b>WACO</b> (The WACO Aircraft Company)                                                                                                                                                                      | YMF                        | Figure 6-28,<br>Figure 6-30           | Figure 6-31,<br>Figure 6-40 | Figure 6-41 | Zone 3,<br>Zone 2A<br>[1][3] | All (fuselage and emp.),<br>Zone 3 (wing) [5] | [8]   |
| <b>WACO Classic Aircraft Corporation</b> [Great Lakes]                                                                                                                                                       | 2T-1A-2                    | Figure 6-29,<br>Figure 6-30           | Figure 6-31,<br>Figure 6-40 | Figure 6-41 | Zone 3,<br>Zone 2A<br>[1][3] | All (fuselage and emp.),<br>Zone 3 (wing) [5] | [8]   |
| <b>W.Z.D. Enterprises Inc.</b><br>(W.Z.D. Enterprises Inc.)<br>[Quartz Mountain Aerospace][Luscombe Aircraft] [JGS Properties, LLC]JGS (JGS Properties, LLC ) [Quartz Mountain Aerospace; Luscombe Aircraft] | 11E                        | Figure 6-28,<br>Figure 6-30           | Figure 6-31                 | Figure 6-41 | Zone 3,<br>Zone 2A<br>[1][2] | All<br>[5][7]                                 |       |
| <b>WSK "PZL-MIELEC" OBR</b> (WSK PZL MIELEC and OBR SK MIELEC) [PZL]                                                                                                                                         | PZL M20 03                 | Figure 6-28,<br>Figure 6-30           | Figure 6-35                 | Figure 6-41 | Zone 3,<br>Zone 2A<br>[1][2] | All<br>[5][7]                                 |       |
| <b>XtremeAir</b> (XtremeAir GmbH)                                                                                                                                                                            | XA42                       | Figure 6-29,<br>Figure 6-30           | Figure 6-31                 | Figure 6-41 | Zone 3<br>[4]                | Zone 3<br>[6]                                 | [8]   |





| Airplane Make (TCDS Holder) [common name or previous make]             | Airplane Model Designation | Lightning Zone Type (Ref. Appendix F) |             |             | GTP 59 Location        | GMU 11 Location                            | Notes |
|------------------------------------------------------------------------|----------------------------|---------------------------------------|-------------|-------------|------------------------|--------------------------------------------|-------|
|                                                                        |                            | Wing                                  | Fuselage    | Empennage   |                        |                                            |       |
| Zenair (Zenair Ltd.)                                                   | CH2000                     | Figure 6-28, Figure 6-30              | Figure 6-31 | Figure 6-41 | Zone 3, Zone 2A [1][2] | All [5][7]                                 |       |
| ZLIN Aircraft a.s. (ZLIN Aircraft a.s.) [Moravan a.s.]                 | Z-242L, Z-143L             | Figure 6-28, Figure 6-30              | Figure 6-31 | Figure 6-41 | Zone 3, Zone 2A [1][2] | All [5][7]                                 |       |
| ZLIN AIRCRAFT a.s. (ZLIN AIRCRAFT a.s.) [Moravan National Corporation] | ZLIN 526L                  | Figure 6-28, Figure 6-30              | Figure 6-31 | Figure 6-41 | Zone 3, Zone 2A [1][3] | All (fuselage and emp.), Zone 3 (wing) [5] | [8]   |

[1] The GTP 59 cannot be installed on Zone 2A composite areas.

[2] The GTP 59 must be bonded to the aluminum skin. For details, refer to Section 4.1.7.

[3] The GTP 59 must be bonded to the metallic tube structure. For details, refer to Section 4.1.7.

[4] The GTP 59 must be isolated from the aircraft ground plane. For details, refer to Section 4.1.7.

[5] The GMU 11 must be bonded to the aircraft ground plane. For details, refer to Section 4.5.4.

[6] The GMU 11 must be isolated from the aircraft ground plane. For details, refer to Section 4.5.4.

[7] The GMU 11 may be mounted in the wingtip provided that certain criteria are met. For details, refer to Section 4.5.4.

[8] Nonmetallic aircraft.

[9] Not used.

[10] With the exception of GTP 59, GMU 11, Glareshield mounted GPS antenna wires, all other installed wires must be routed behind metallic substructure (i.e., routed behind instrument panel/pedestal/circuit breaker panel, along lightning ground bar/strip, inside lightning ground tube, or along other airframe ground plane).

[11] Only for aluminum wings. Not allowed for wooden wings.

## APPENDIX F - LIGHTNING PROTECTION







### F.1 Lightning Zones for GTP 59 and GMU11

This section provides lightning zoning diagrams for various types of aircraft to facilitate correct placement of the GTP 59 and GMU11. Additional restrictions related to the placement of the GTP 59 can be found in Section 4.1.7. Additional restrictions related to the placement of the GMU 11 can be found in Section 4.1.3.

The zoning levels correspond to the severity of lightning strikes and probability of occurrence on the aircraft. The order of severity starting with the safest zone is Zone 3, 2A, 2B, 1C, and 1A/1B. The GTP 59 cannot be installed in Zones 1A, 1B, 1C, or 2B.

All diagrams in this appendix use the legend shown in Table 6-4. The zoning described is split into the following: wings, fuselage, and empennage. For the particular airframe, the applicable wings, fuselage, and empennage zoning should be merged to get a complete zonal definition. The zoning figures applicable to any particular model are found in Table 6-3. If there is a region of overlapping zones, the more severe zone should always be applied (i.e., if Zone 2A and 1A overlap in a region, then the overlapping region should be considered Zone 1A). Examples of complete lightning zoning diagrams can be found in Appendix Section F.2.

**Table 6-4: Lightning Zoning Legend**

|                                                                                     |         |                                                                                     |         |
|-------------------------------------------------------------------------------------|---------|-------------------------------------------------------------------------------------|---------|
|    | Zone 1A |    | Zone 2A |
|   | Zone 1B |   | Zone 2B |
|  | Zone 1C |  | Zone 3  |

#### F.1.1 Wings

The different zoning for wingtips and wings are contained in the following subsections.

##### F.1.1.1 Wingtips

###### F.1.1.1.1 Aircraft Not Limited to VFR Operation



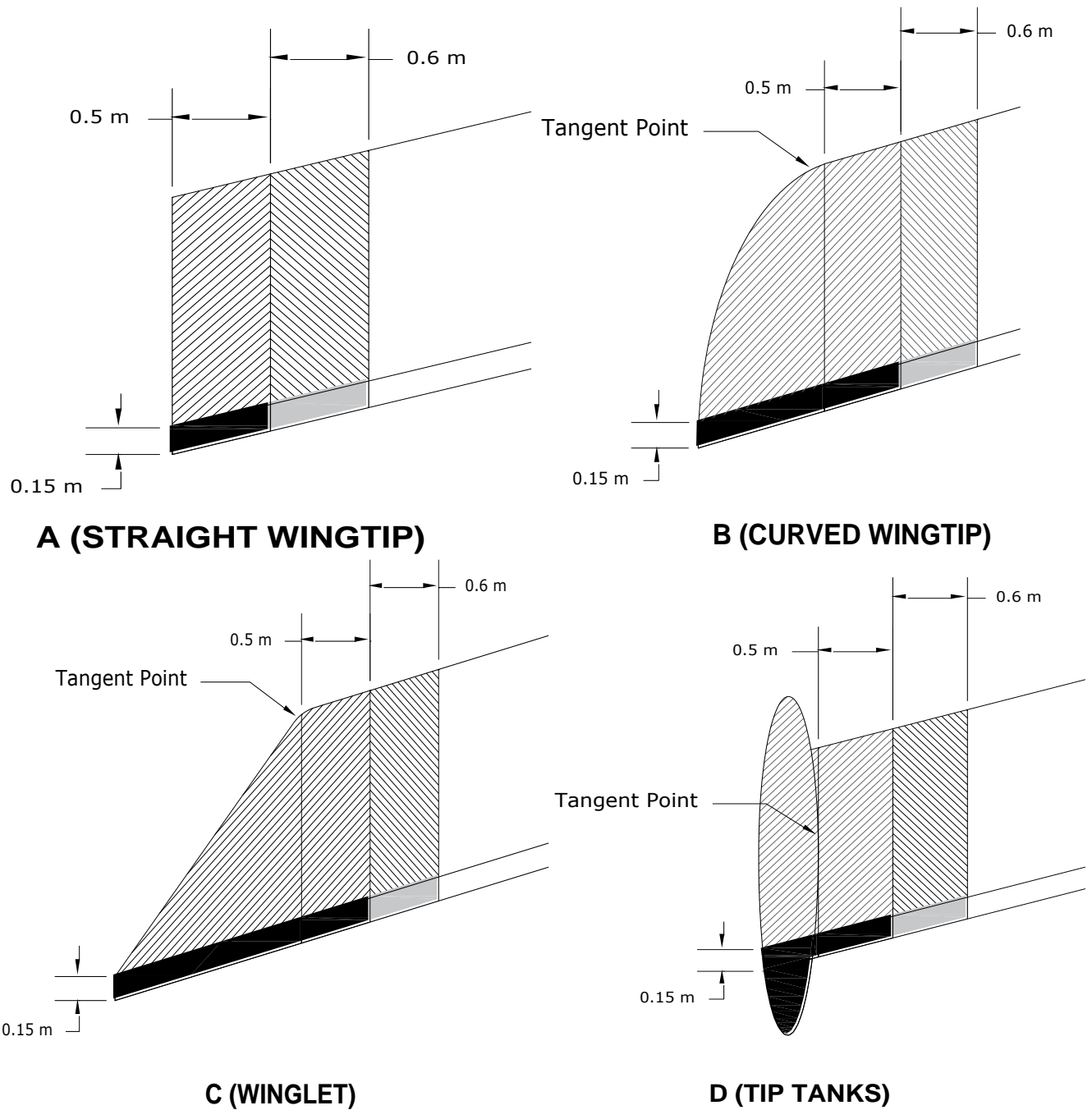
#### NOTE

*This zoning section is applicable to those aircraft models that are not limited to VFR operation only in Table 6-3. For zoning of models limited to VFR operation only, refer to Appendix Section F.1.1.1.2.*

Zoning of various types of wingtips is shown in Figure 6-28. Figure 6-28A shows zoning for straight wingtips. Figure 6-28B shows zoning for curved wingtips. The zones are similar to those of straight wingtips. The main difference is that Zone 1 extends from the outboard edge of the wing past the tangent point of the chord and 0.5 meters inboard.

Figure 6-28C shows zoning for winglets. Note that the winglet figure shows a flattened winglet. Winglet classifications are very similar to those of curved wingtips. The main difference is that Zone 1 extends from the outboard edge of the wing past the tangent point of the winglet and 0.5 meters inboard.

Figure 6-28D shows zoning for tip tanks. The rule that applies to tip tanks is very similar to that of the curved wing. The main difference is that Zone 1 extends 0.5 meters past the inboard edge of the tip tank.



**Figure 6-28 Zoning for Wingtips on Aircraft Not Limited to VFR Operation**



#### F.1.1.1.2 Aircraft Limited to VFR Operation

This zoning section is applicable to those aircraft models that are limited to VFR operation only in APPENDIX E. For zoning of models that are not limited to VFR operation only, refer to Appendix Section F.1.1.1.1.

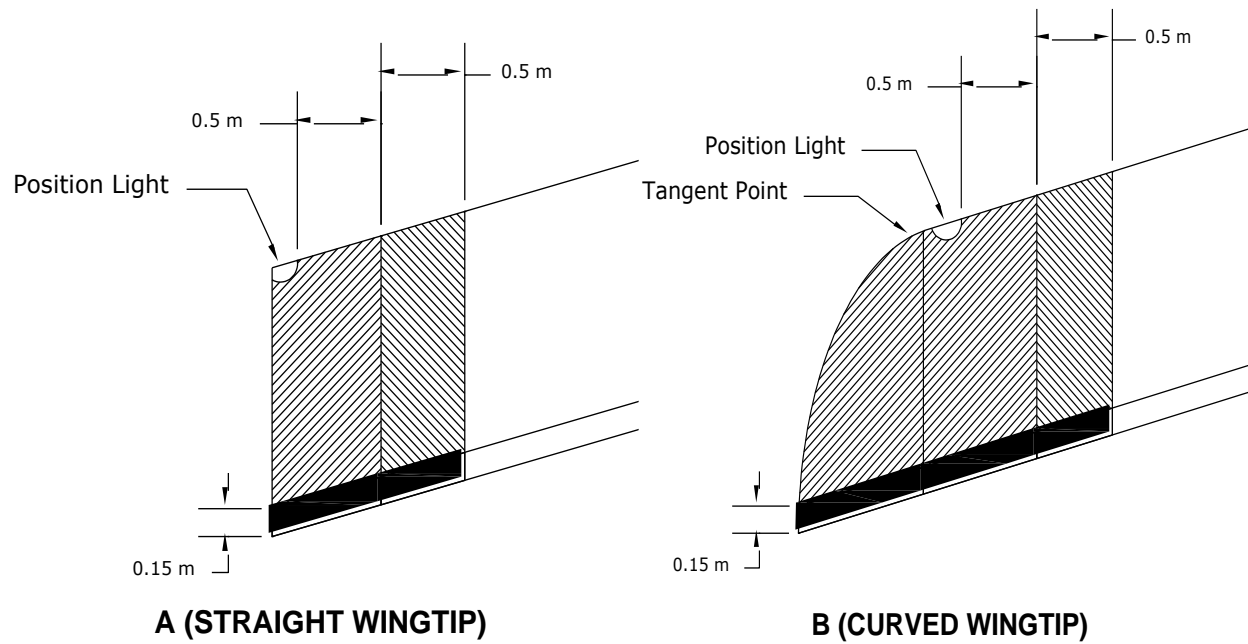


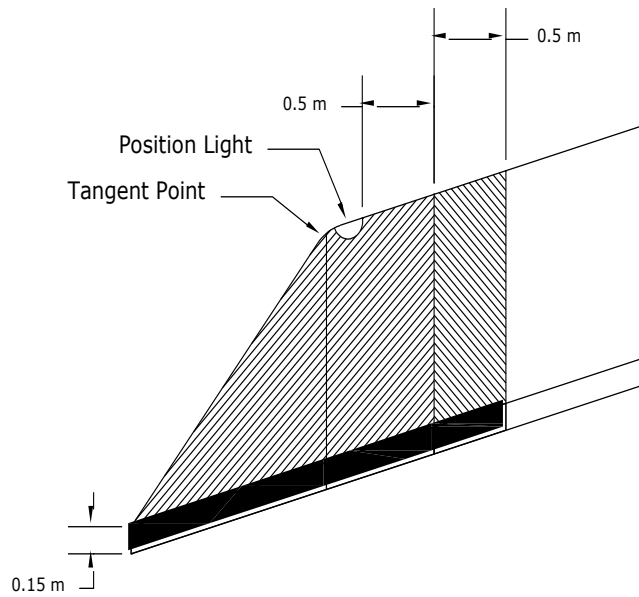
#### **NOTE**

*The aircraft must have a position light in the wing tip area as a prerequisite for installing the GMU 11 or GTP 59.*

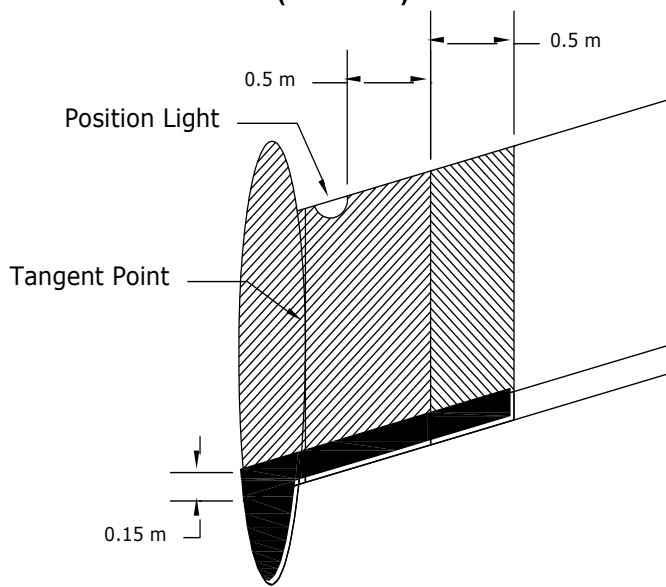
If there is no position light on the wing, then no Zone 3 exists and the GTP 59 cannot be installed on this particular aircraft. For those aircraft identified as VFR in Appendix D, the following criteria is used to determine the Zone 3 area:

- Zone 1A/1B finishes as shown in Figure 6-29 **or** 0.5 meters inboard from the inboard edge of the position light, whichever is the greater distance from the outboard edge of the wing tip, as shown in Figure 6-28
- Zone 2A/2B extends a total of 2.1 meters inboard of Zone 1A/1B
- Zone 3 extends inboard of Zone 2A/2B from the wing tip and stops at another Zone 1A/1B or 2A/2B determined from other areas of Appendix Section F.1.2





**C (WINGLET)**

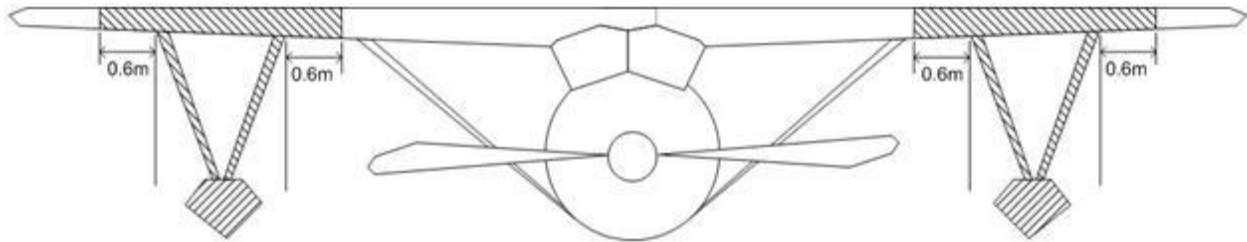


**D (TIP TANKS)**

**Figure 6-29 Zoning for Wingtips on Aircraft Limited to VFR Operations**

### F.1.1.2 Landing Gear

The landing gear is considered Zone 1A. The struts that connect the landing gear to the wings are Zone 2A. Each side of landing gear is zoned individually. If there is a single strut connecting the landing gear to the wing, then the inboard and outboard edges of the landing gear should be used for zoning instead of using the connection point of the wing and the strut. In addition to the zoning shown in Figure 6-30, the zoning described for the fuselage and wings also applies. The floats for a float-mounted fuselage have not been zoned because they do not influence the zoning of the bottom of the fuselage. The GTP 59 and GMU11 cannot be mounted on landing gear, including floats, or its struts.



**Figure 6-30 Zoning for Wings Affected by Landing Gear**

### F.1.2 Fuselage

This section describes the zoning for several different types of fuselages. The empennage is zoned in Appendix Section F.1.3. Aft of every Zone 2A is a 0.15 meter Zone 2B (i.e., Zone 2A is followed by a 0.15 meter Zone 2B). Although Zone 2B areas are marked on the diagrams, sometimes their widths are not defined (0.15 meters should be used in these cases). The horizontal stabilizer of the tail is NOT zoned because neither the GTP 59 nor the GMU 11 can be mounted there. In addition, neither the GTP 59 nor the GMU 11 can be mounted within 0.5 meters of the rear-most point of the fuselage. Appendix Section F.1.3 explains the conditions under which the GTP 59 or GMU 11 can be mounted on the vertical stabilizer. Although all diagrams show low wing aircraft, the same zoning can be applied to high wing aircraft. The values d1 and d2 are defined as follows:

d1 = 1.3m (51.2")

d2 = 2.6m (102.4")

## F.1.2.1 Single-Propeller Aircraft

Zoning of low- or high-wing aircraft with single propellers is shown in Figure 6-31. The area of the nose immediately aft of the propeller is Zone 3. The 0.6 meter distance should be measured from the outboard most edge of the fuselage or the tip of the propeller, whichever is longer. Figure 6-33 shows the case of an aircraft with a curved fuselage. The portion of the fuselage that extends 1.3 meters aft of the propeller blades is Zone 1C. However, the bottom centerline is Zone 2A, and it is acceptable to mount the GTP 59 there.

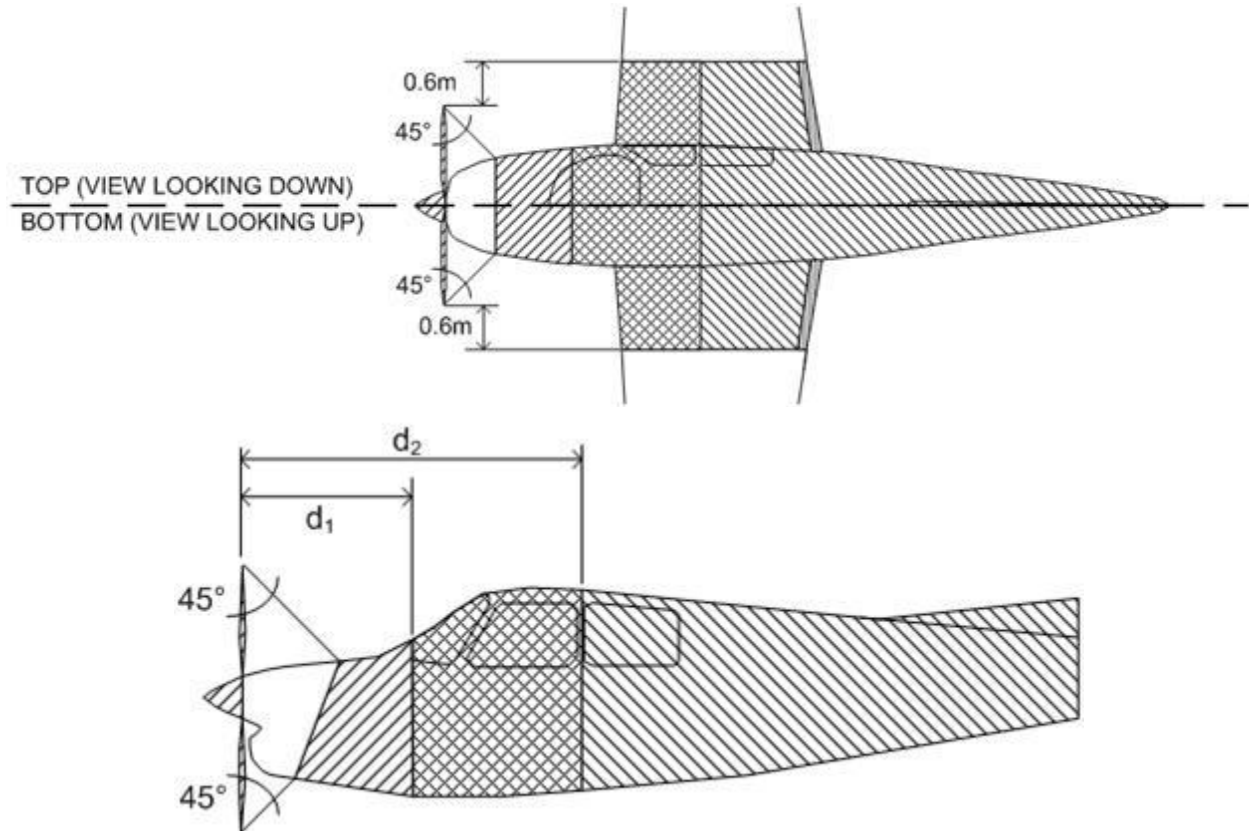
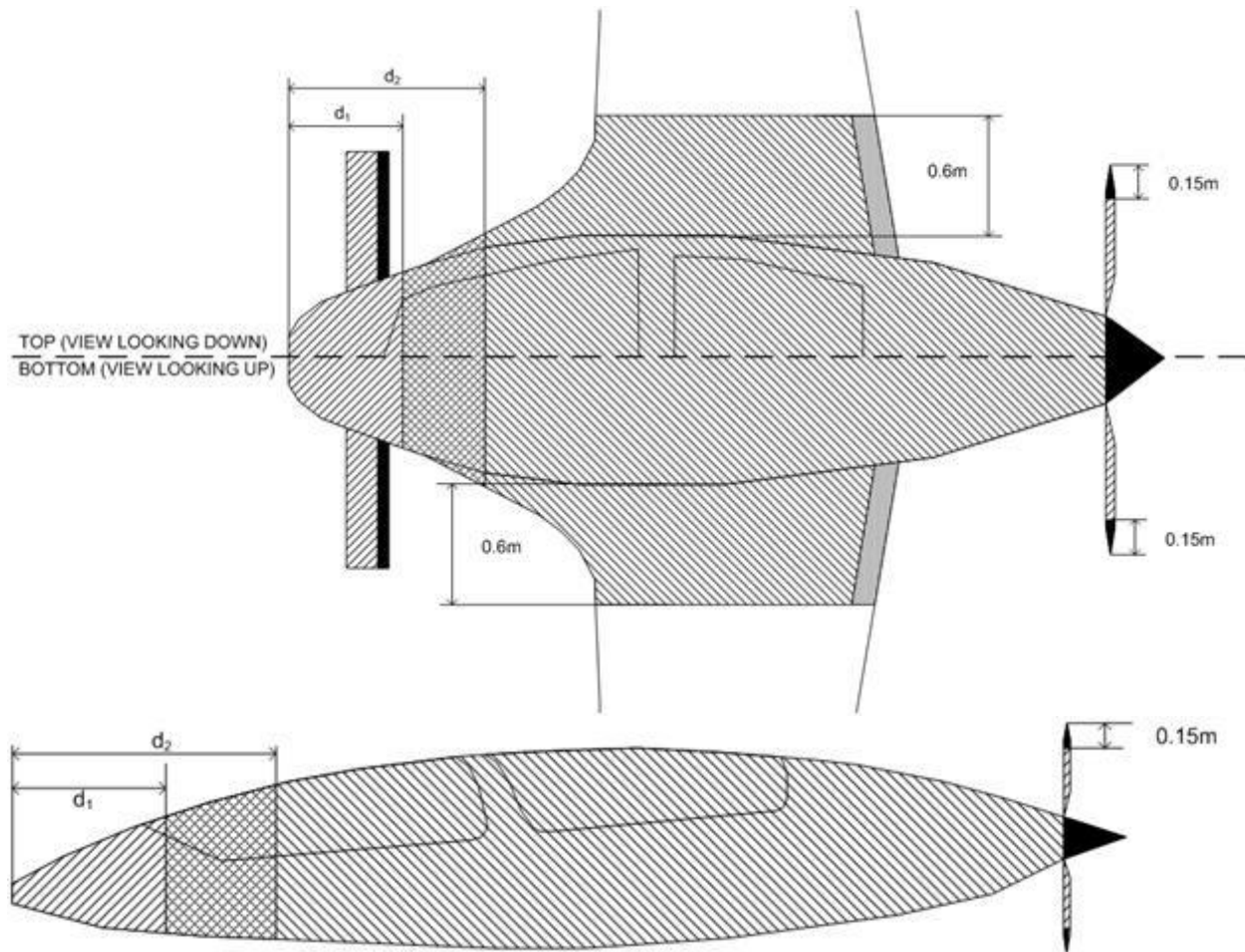
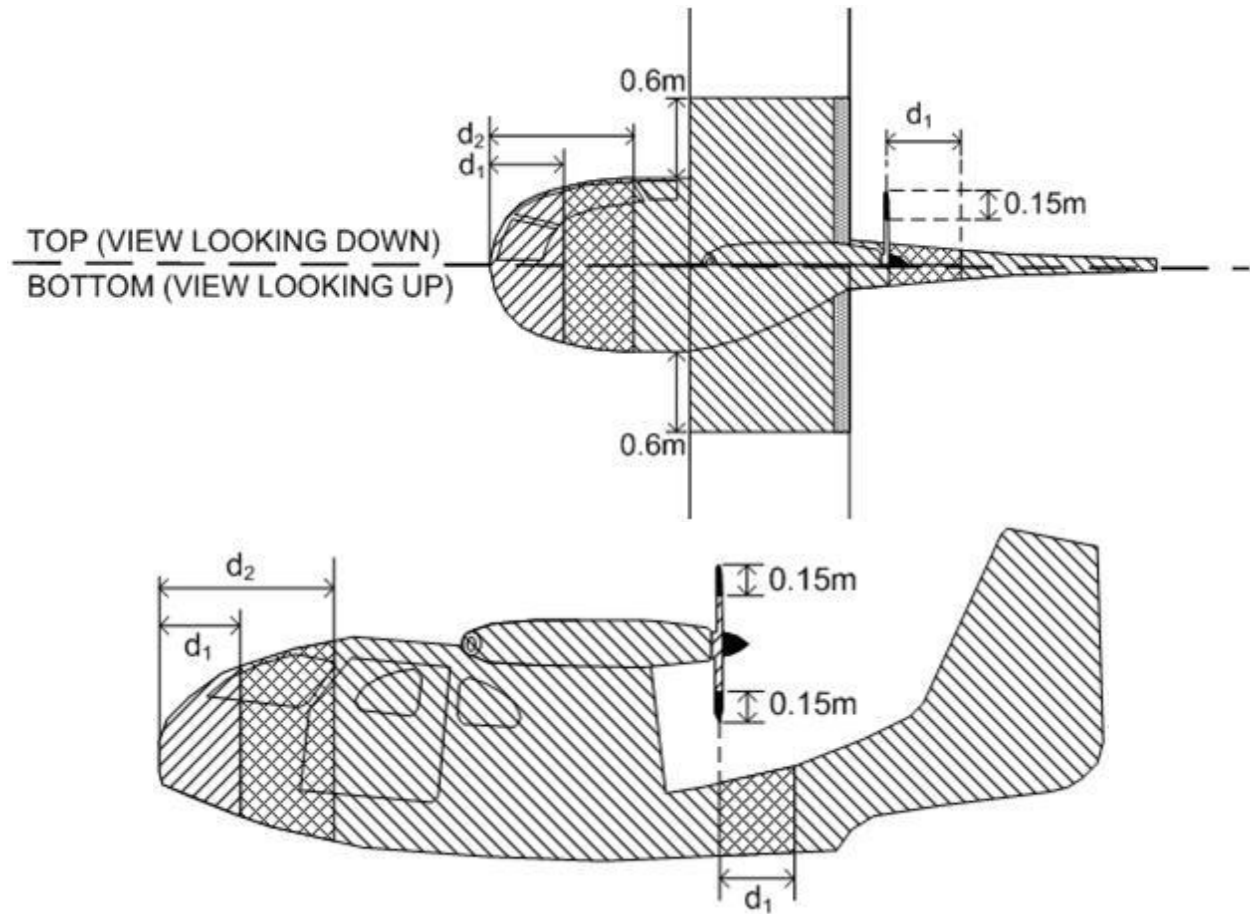


Figure 6-31 Zoning for a Single Propeller (Low- or High-Wing)





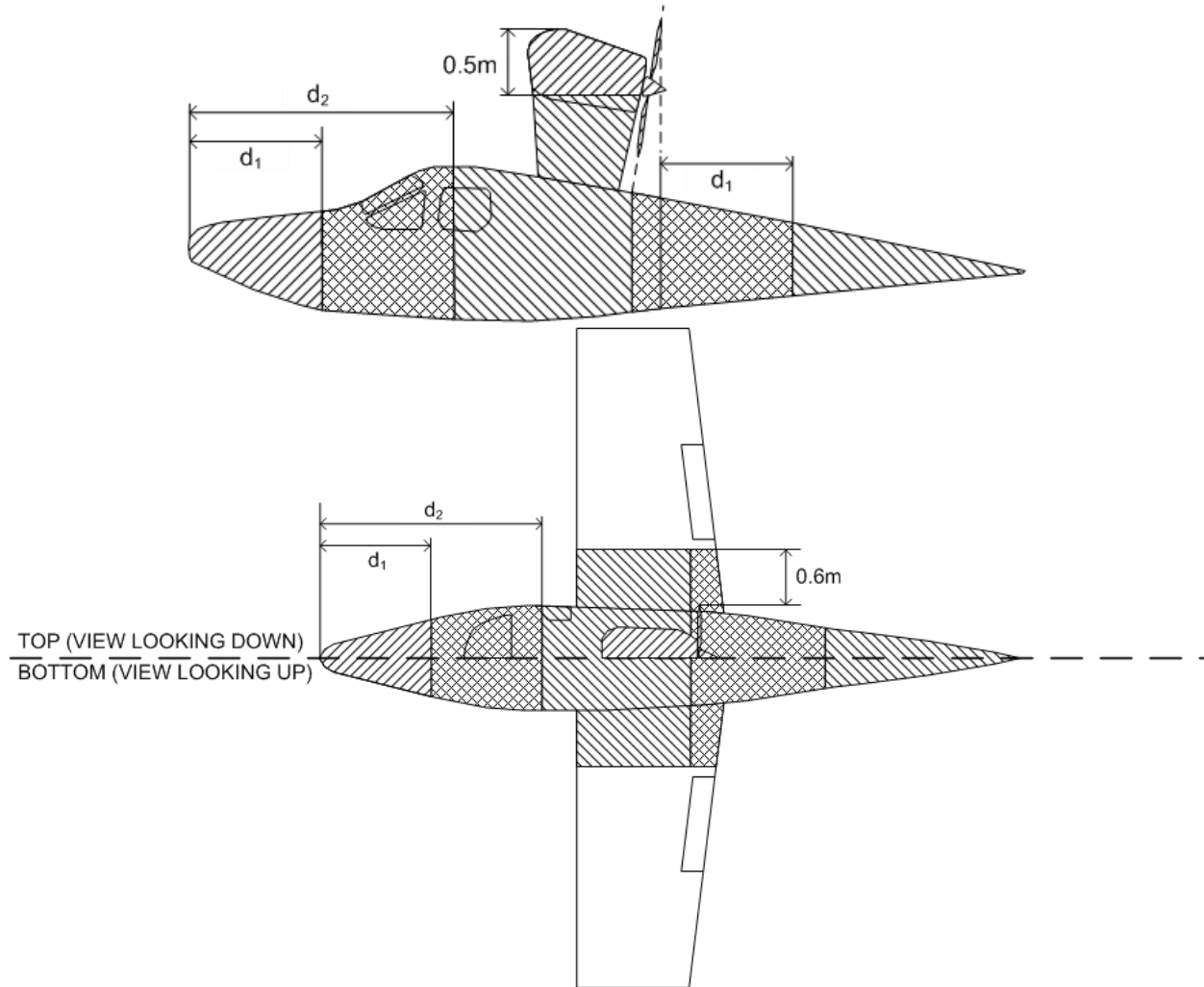
**Figure 6-32 Zoning for a Low- or High-Wing Canard with a Rear-Mounted Propeller**



**NOTE**

*The bottom centerline is Zone 2A, and it is acceptable to mount the GTP 59 there.*

**Figure 6-33 Zoning for a Low- or High-Wing Aircraft with a Curved Lower Fuselage**



**Figure 6-34 Zoning for a Single, Rear-Mounted Prop above Fuselage**

## F.1.2.2 Aircraft with Multiple Propellers

Zoning of low- or high-wing aircraft with twin front-mounted propellers is shown in Figure 6-35. The text below assumes the aircraft fuselage and wing are constructed of metal. Note that Zone 2A can overlap onto the nacelles if they are within 0.6 meters outboard of the fuselage.

Zoning of low- or high-wing aircraft with rear-mounted twin propellers is shown in Figure 6-36. The text below assumes the aircraft fuselage and wing are constructed of metal.

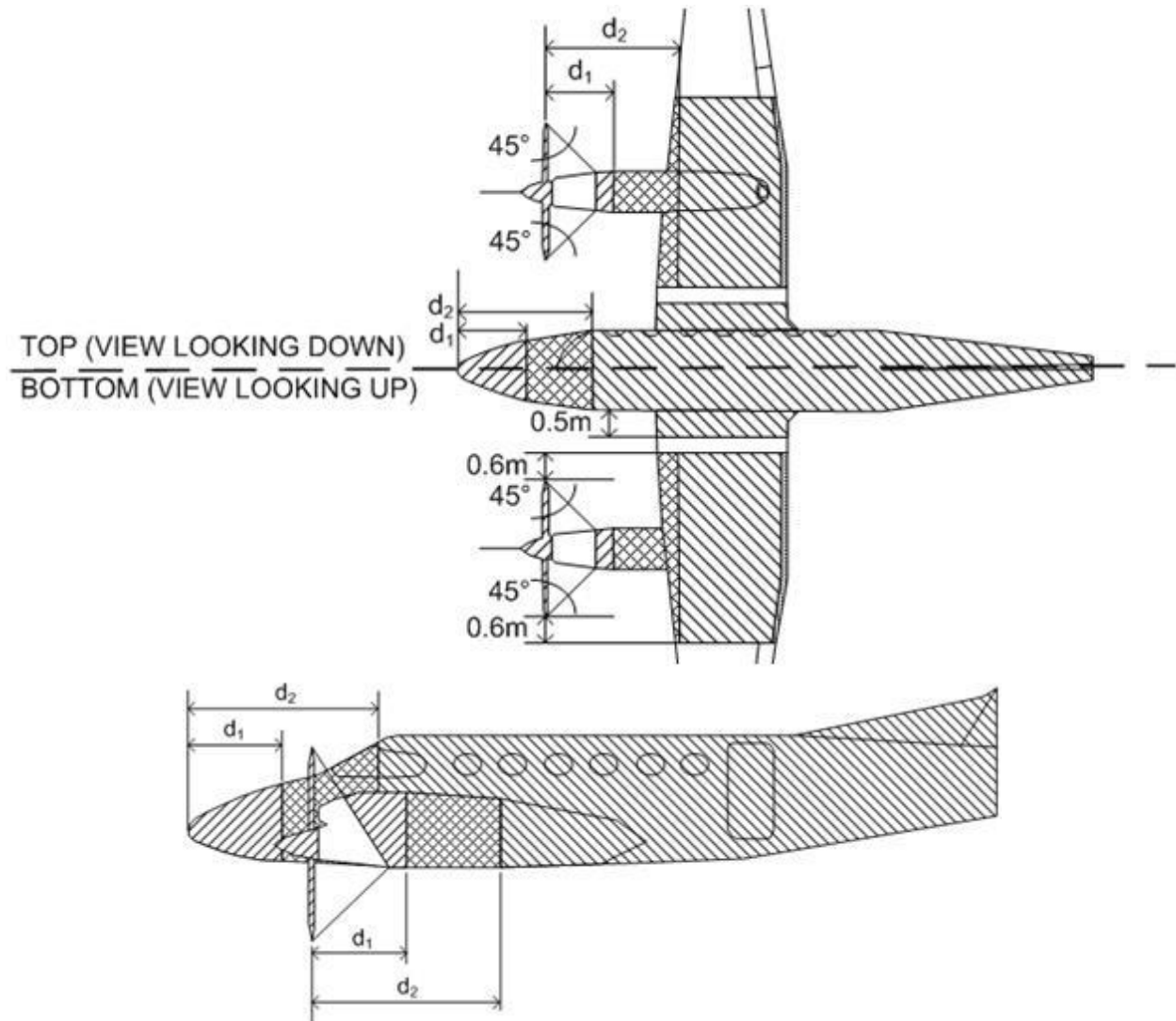
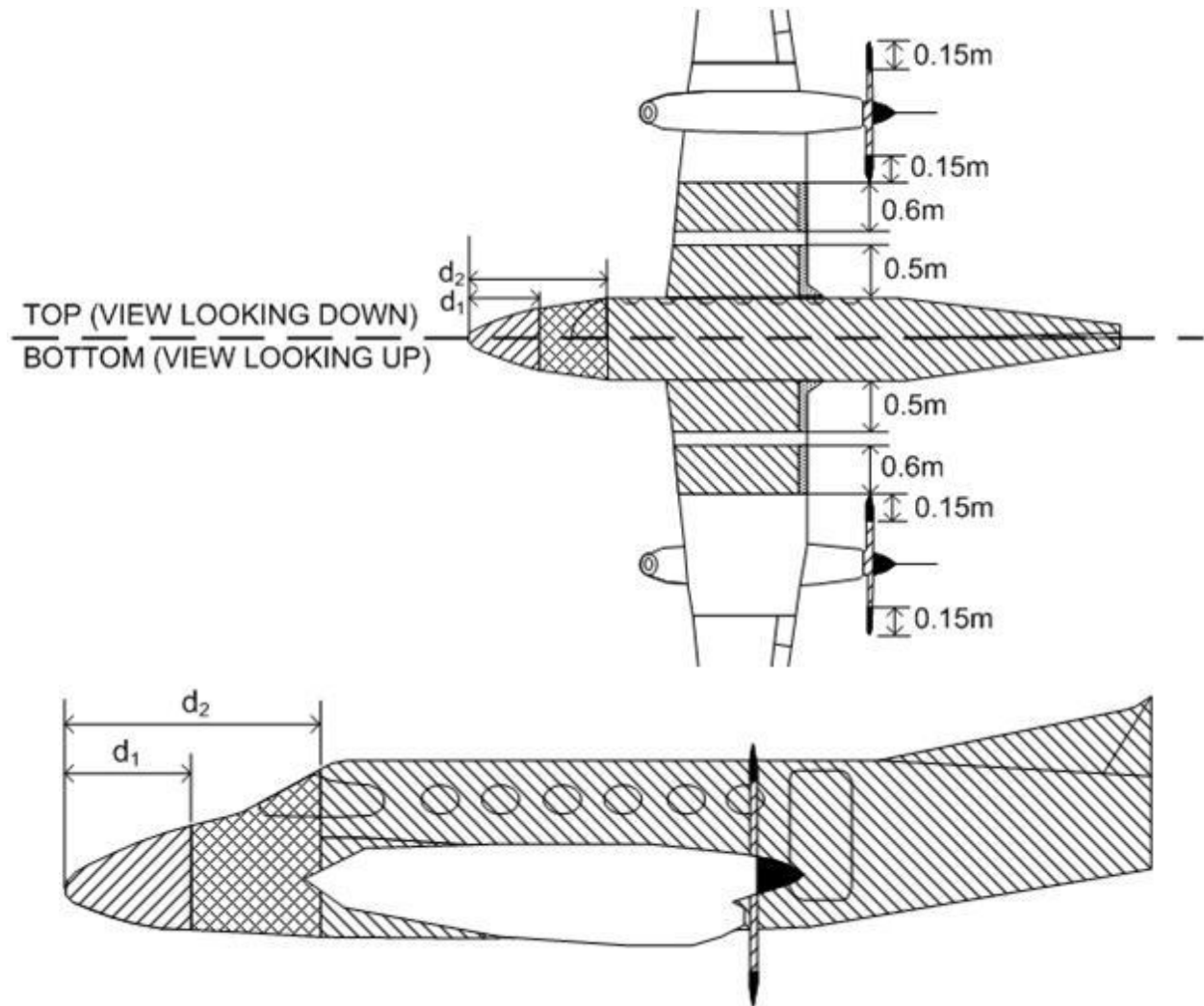


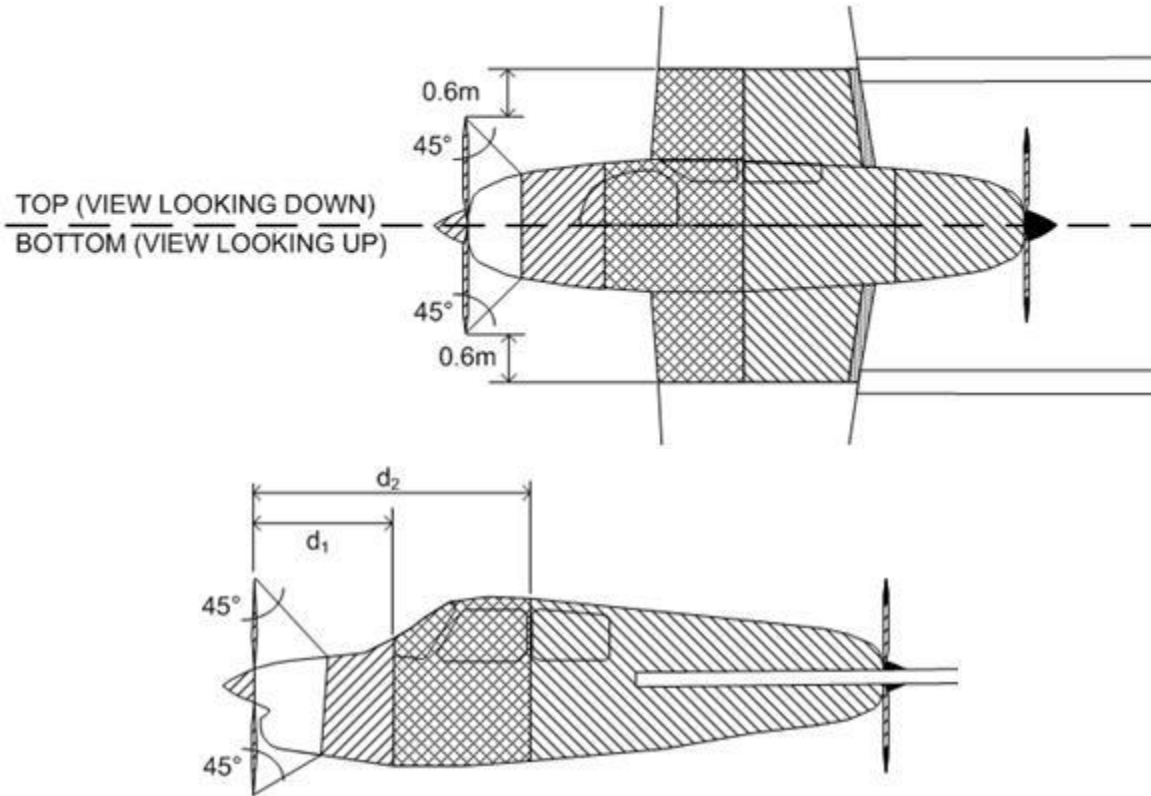
Figure 6-35 Zoning for Front-Mounted Twin Propellers (Low- or High-Wing)



## NOTE

Although the engine nacelles are shown as Zone 3, they may be Zone 2A if the engine falls within the Zone 2 area of the wing (within 0.6 meters outboard from fuselage edge).

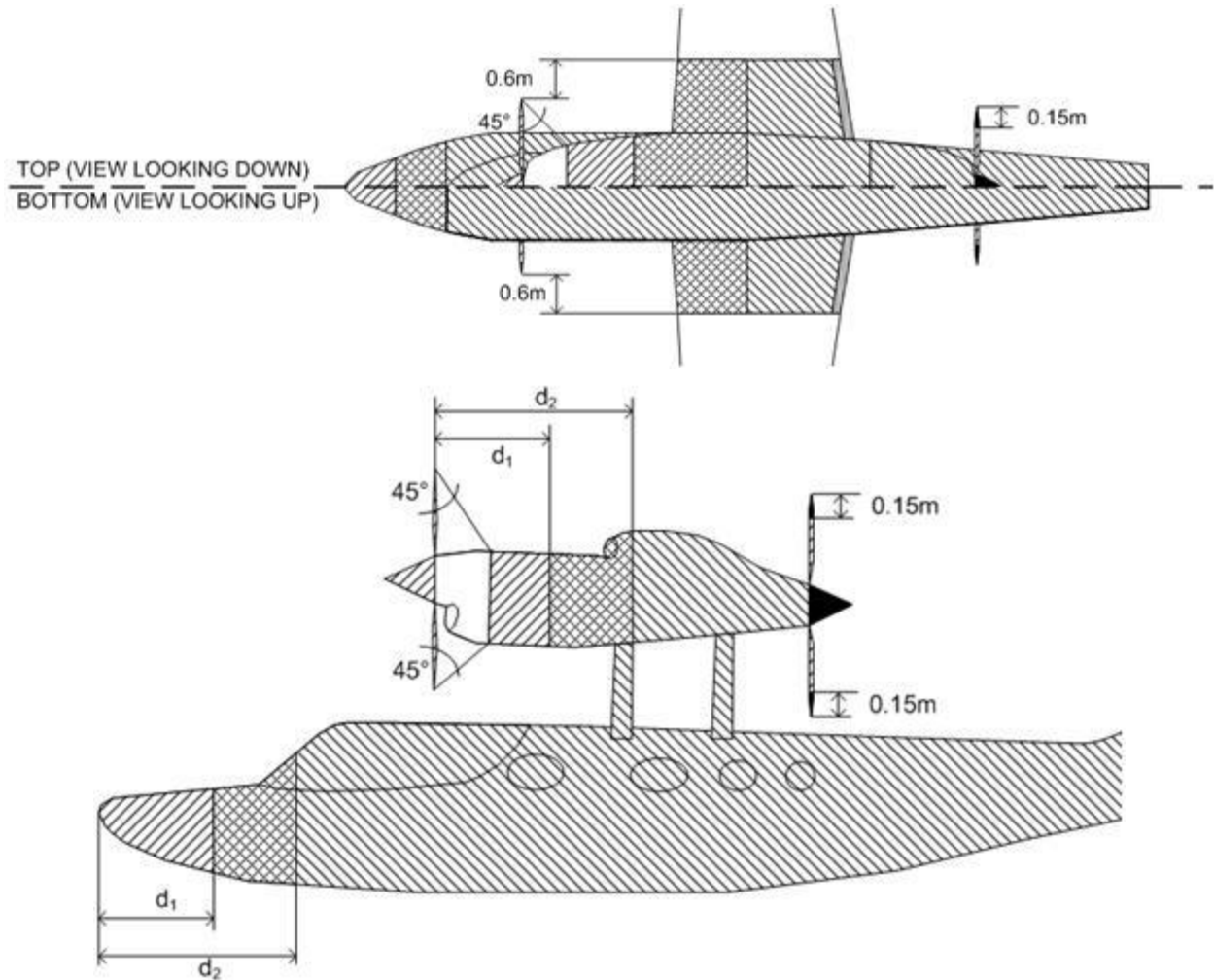
**Figure 6-36 Zoning for Rear-Mounted Twin Propellers (Low- or High-Wing)**



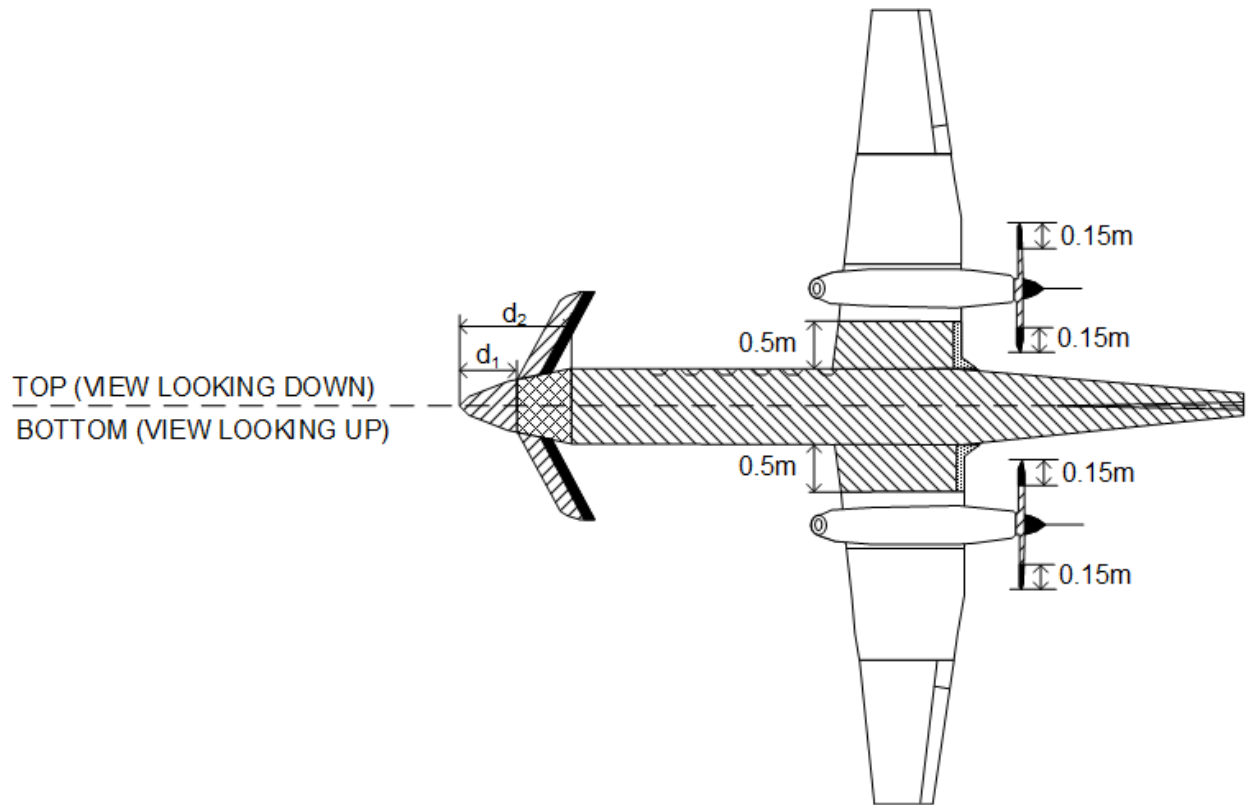
**NOTE**

*Nothing can be mounted in the tail boom of the aircraft.*

**Figure 6-37 Zoning for Front- and Rear-Mounted Propellers (Low- or High-Wing)**



**Figure 6-38 Zoning for High-Wing with Front and Rear Propellers Mounted Above Fuselage**

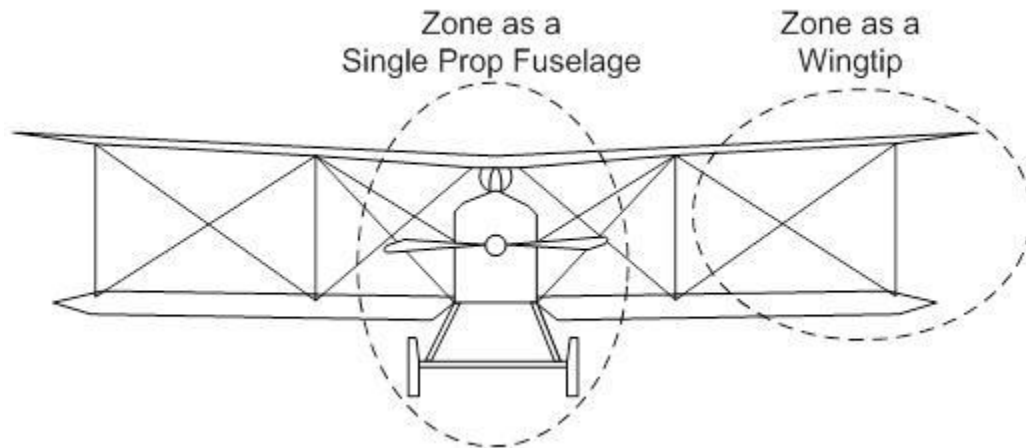


**Figure 6-39 Zoning for Low or High Wing Canard with Twin Rear-Facing Props**



## F.1.2.3 Biplanes

Figure 6-40 shows how biplanes can be classified using the figures from above. The top and bottom of both wings will be zoned using Figure 6-29, while the fuselage and the mid-sections of the wing can be zoned using Figure 6-31.



**Figure 6-40 Zoning for Single-Propeller Biplane**

## F.1.3 Empennage

If the GTP 59 and GMU 11 cannot be mounted in other areas of the aircraft that are Zone 3 locations, it is acceptable for metal aircraft with one of the four traditional empennages shown in Figure 6-41 and Figure 6-42 to mount the GTP 59 or GMU 11 in the Zone 2A area of the tail. However, the GTP 59 or GMU 11 cannot be mounted on/under any non-conducting surfaces. If the complete empennage of the aircraft being considered does not match those shown in Figure 6-41 or Figure 6-42, then it should be mounted in allowed areas defined for the fuselage and wings. If only portions of the empennage shown below match, then the same rule applies and the GTP 59 or GMU 11 cannot be installed in the empennage. Note that it is allowable for only the horizontal stabilizer tips to differ from those shown in Figure 6-41 and Figure 6-42. The GTP 59 cannot be located in the horizontal stabilizer of the empennage. Neither the GTP 59 nor the GMU 11 can be mounted in the tail of a composite empennage.

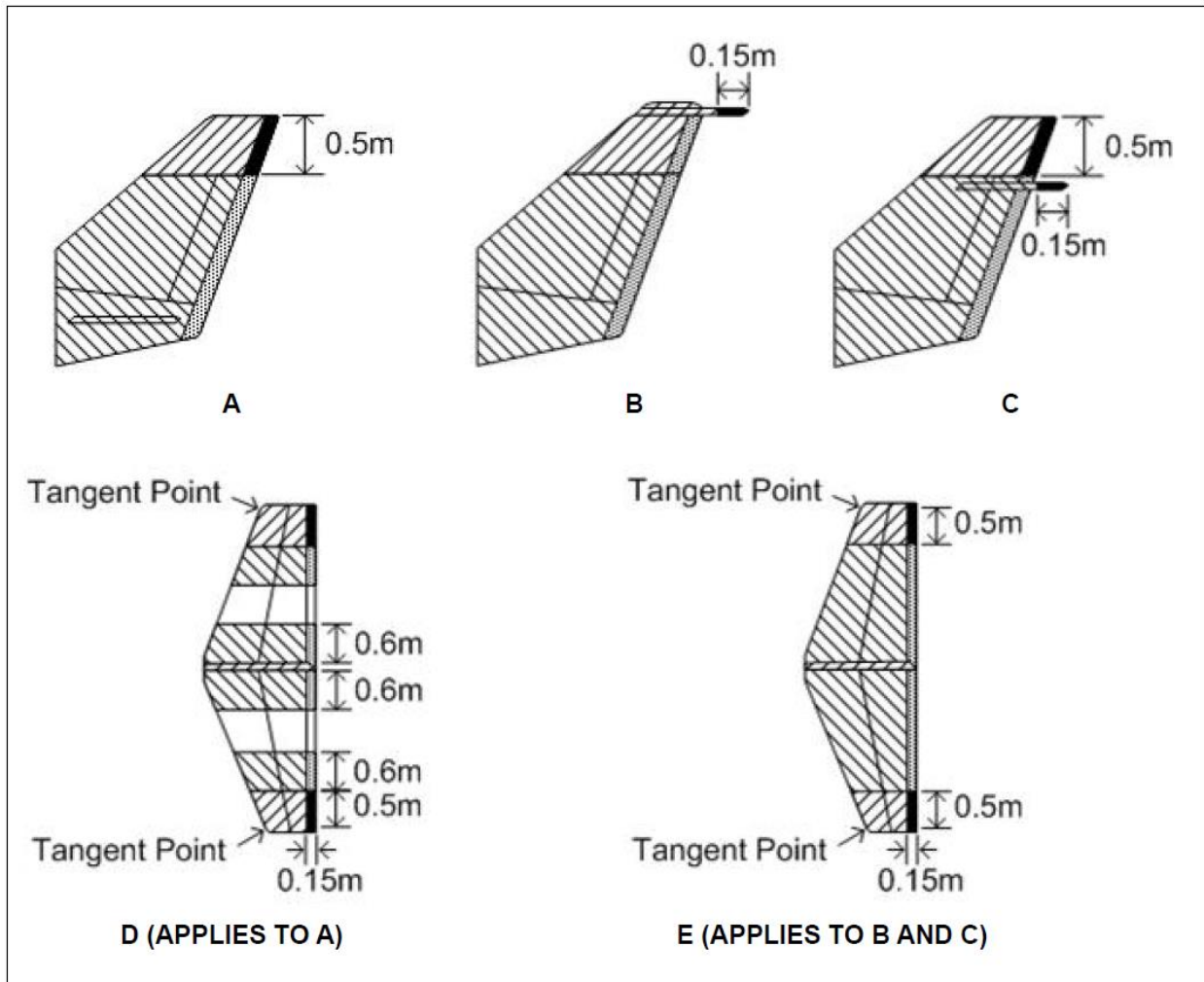
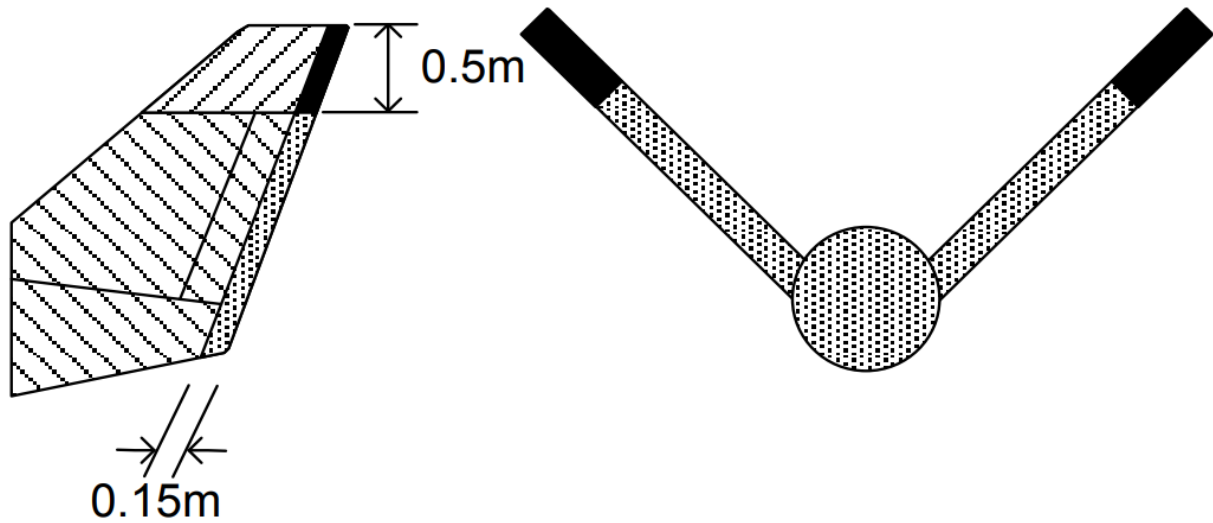
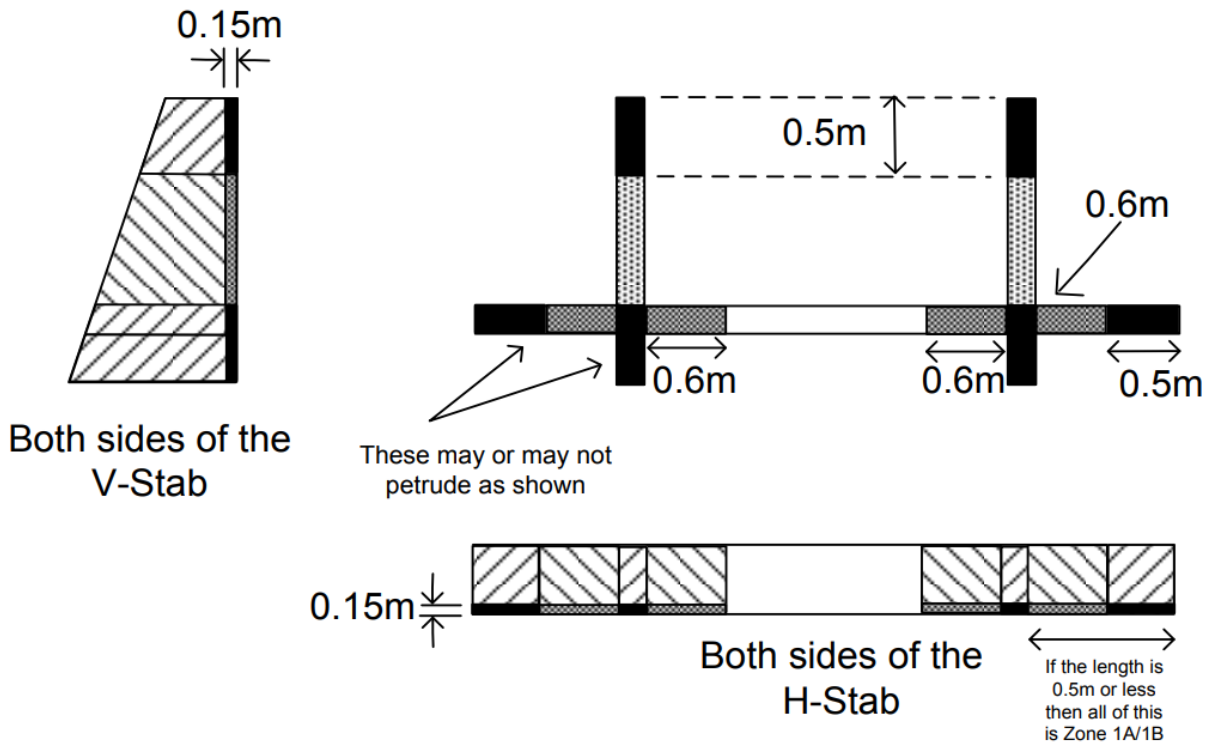


Figure 6-41 Zoning for Empennage



**Figure 6-42 V-tail Empennage Zoning**



**Figure 6-43 Dual Vertical Stabilizer With Low Horizontal Stabilizer Zoning**

## F.2 Example Lightning Zoning Diagrams

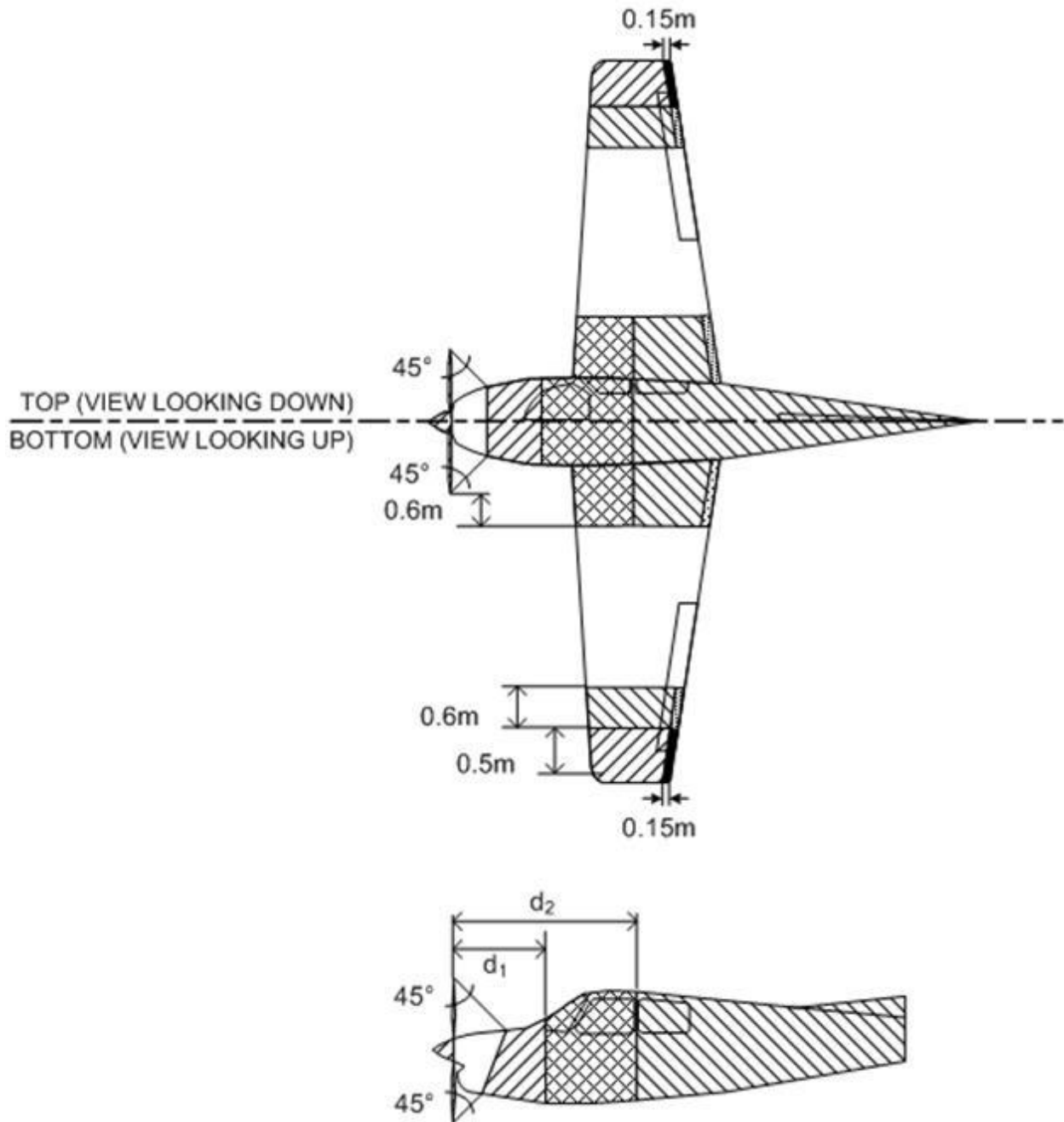
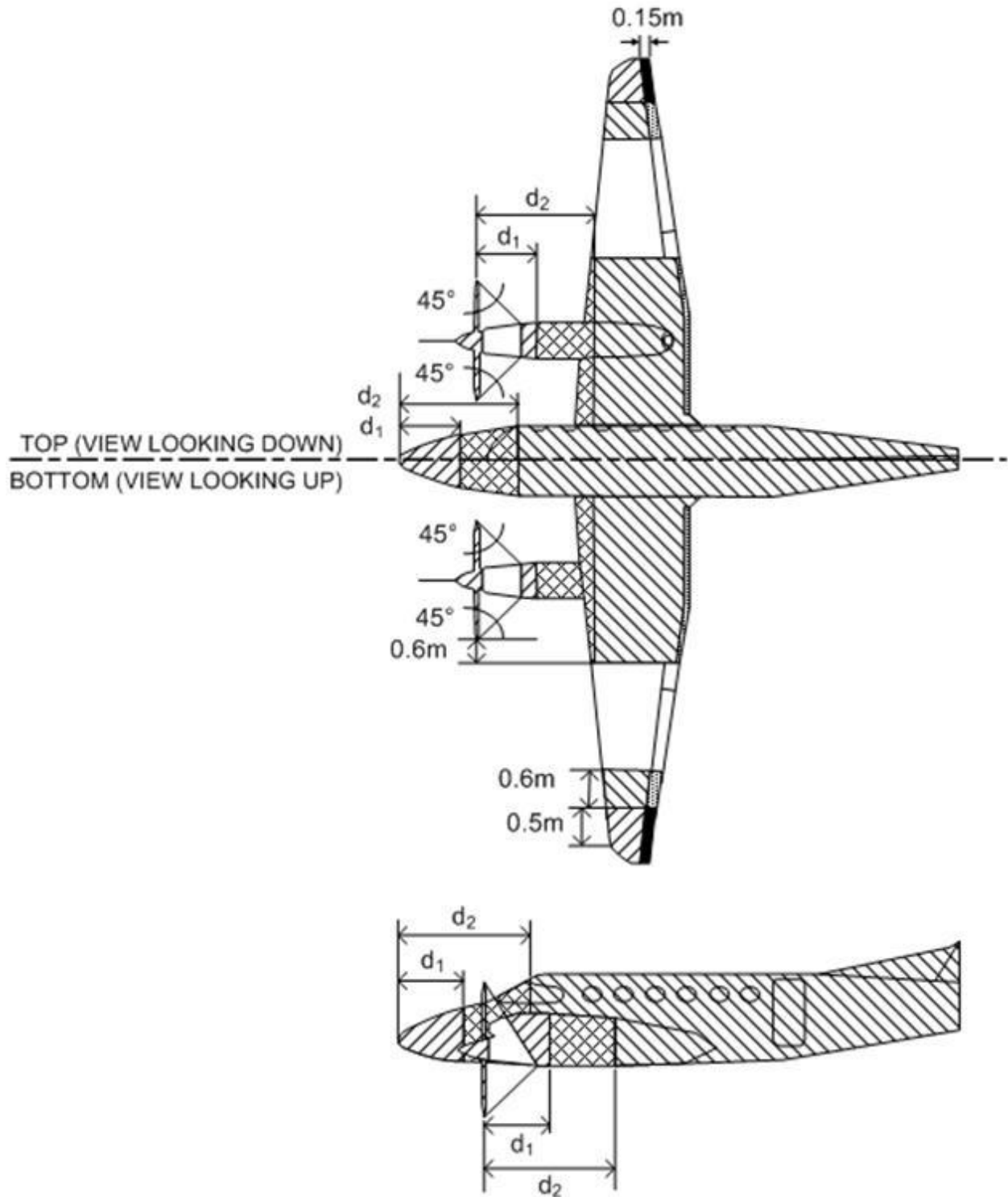


Figure 6-44 Example Lightning Zoning for Single-Engine Aircraft



**Figure 6-45 Example Lightning Zoning for Twin-Engine Aircraft**