

**GARMIN.**  
**G1000** **NXi**

# **Supplemental Maintenance Manual**

**Textron Aviation Inc.  
NAV III Aircraft**

**Includes Instructions for Continued Airworthiness  
for STC SA01945WI**

© Copyright 2020-2022  
Garmin Ltd. or its subsidiaries  
All Rights Reserved

Except as expressly provided herein, no part of this manual may be reproduced, copied, transmitted, disseminated, downloaded or stored in any storage medium, for any purpose without the express prior written consent of Garmin. Garmin hereby grants permission to download a single copy of this manual and of any revision to this manual onto a hard drive or other electronic storage medium to be viewed and to print one copy of this manual or of any revision hereto, provided that such electronic or printed copy of this manual or revision must contain the complete text of this copyright notice and provided further that any unauthorized commercial distribution of this manual or any revision hereto is strictly prohibited.

Garmin International, Inc.  
1200 E. 151st Street  
Olathe, KS 66062 USA  
Telephone: 913.397.8200  
www.garmin.com

Garmin (Europe) Ltd.  
Liberty House, Bulls Copse Road  
Hounslow Business Park  
Southampton, SO40 9RB, UK  
Phone: +44 (0) 23 8052 4000  
Fax: +44 (0) 23 8052 4004

Garmin AT, Inc.  
2345 Turner Rd., SE  
Salem, OR 97302 USA  
Telephone: 503.581.8101

### **RECORD OF REVISIONS**

<b>Revision</b>	<b>Date</b>	<b>Description</b>
1	6/10/20	Initial Release
2	5/14/21	Rework manual for G1000 NXi field retrofit.
3	9/16/22	Adding GSU 75 ADAHRS and new Software image

### **DOCUMENT PAGINATION**

<b>Section</b>	<b>Pagination</b>
Table of Contents	i – vi
Section 1	1-1 – 1-5
Section 2	2-1 – 2-7
Section 3	3-1 – 3-42
Section 4	4-1– 4-8
Section 5	5-1 – 5-29
Section 6	6-1 – 6-9
Section 7	7-1– 7-22
Section 8	8-1 – 8-3
Section 9	9-1 - 9-8
Appendix A	A-1

---

## **INFORMATION SUBJECT TO EXPORT CONTROL LAWS**

This document may contain information which is subject to the Export Administration Regulations (“EAR”) issued by the United States Department of Commerce (15 CFR, Chapter VII Subchapter C) and which may not be exported, released or disclosed to foreign nationals inside or outside the United States without first obtaining an export license. The preceding statement is required to be included on any and all reproductions in whole or in part of this manual.

### **WARNING**

This product, its packaging, and its components contain chemicals known to the State of California to cause cancer, birth defects, or reproductive harm. This Notice is being provided in accordance with California's Proposition 65. If you have any questions or would like additional information, please refer to our web site at [www.garmin.com/prop65](http://www.garmin.com/prop65).

### **CAUTION**

The GDU lens is coated with a special anti-reflective coating that is very sensitive to skin oils, waxes and abrasive cleaners. **CLEANERS CONTAINING AMMONIA WILL HARM THE ANTI-REFLECTIVE COATING.** It is very important to clean the lens using a clean, lint-free cloth and an eyeglass lens cleaner that is specified as safe for anti-reflective coatings.

### **IMPORTANT**

All G1000 screen shots used in this document are current at the time of publication. Screen shots are intended to provide visual reference only. All information depicted in screen shots, including software file names, versions and part numbers, is subject to change and may not be up to date.

---

## TABLE OF CONTENTS

PARAGRAPH	PAGE
<b>1. INTRODUCTION.....</b>	<b>1-1</b>
1.1 Content, Scope, Purpose .....	1-1
1.2 Organization.....	1-2
1.3 Definitions/Abbreviations.....	1-3
1.4 Units of Measure .....	1-4
1.5 Publications.....	1-4
1.6 Revision and Distribution.....	1-5
<b>2. SYSTEM DESCRIPTION .....</b>	<b>2-1</b>
2.1 Equipment Descriptions .....	2-1
2.2 G1000 Optional Interfaces .....	2-4
2.3 Electrical Power Distribution.....	2-4
2.4 Pitot/Static System .....	2-4
2.5 GDU 1054B and GDU 1050 Displays.....	2-4
2.6 Softkeys .....	2-4
2.7 FMS Knob.....	2-4
2.8 G1000 Normal Mode.....	2-5
2.9 Reversionary Mode .....	2-7
<b>3. SOFTWARE AND CONFIGURATION .....</b>	<b>3-1</b>
3.1 Configuration Mode Overview .....	3-1
3.2 G1000 System Software Information.....	3-5
3.3 Configuration Mode.....	3-12
3.4 G1000 Hardware/Software Compatibility Check.....	3-13
3.5 Equipment Verification (Third Party/Optional Equipment Documentation) .....	3-14
3.6 G1000 Software/Configuration Procedure .....	3-15
3.7 System Software and Configuration Load .....	3-16
3.8 Feature Enablement.....	3-31
3.9 Aircraft Registration Number Entry and Flight ID Configuration .....	3-35
3.10 Configuration Manager.....	3-36
3.11 Splash Screen Loading .....	3-36
3.12 Database Loading .....	3-37
3.13 Clearing Default User Settings .....	3-39
3.14 Interface Confirmation .....	3-40
3.15 Flight Stream 510 Firmware Review.....	3-41
<b>4. INSTRUCTIONS FOR CONTINUED AIRWORTHINESS .....</b>	<b>4-1</b>
4.1 Airworthiness Limitations.....	4-1
4.2 Servicing Information.....	4-2
4.3 Maintenance Intervals .....	4-4
4.4 Electrical Bonding Test.....	4-5
4.5 GSU 75 Earth Magnetic Field Updates.....	4-6
4.6 G1000 Redundant Connection Check .....	4-6
<b>5. TROUBLESHOOTING .....</b>	<b>5-1</b>
5.1 System Annunciations.....	5-2
5.2 G1000 Alerting System .....	5-9
5.3 Synthetic Vision and Pathways Troubleshooting .....	5-11
5.4 Backup Communications Path Checks.....	5-12
5.5 GDU 105X Troubleshooting .....	5-12
5.6 GDU 105X Alerts.....	5-14
5.7 GSU 75 and GMU 44 Troubleshooting.....	5-18
5.8 GSU 75 Troubleshooting.....	5-22
5.9 GTX Troubleshooting .....	5-23

5.10	GDL 69A SXM Troubleshooting (if installed) .....	5-24
5.11	Software/Configuration Troubleshooting.....	5-26
5.12	Backshell/Backplate Connectors .....	5-28
<b>6.</b>	<b>EQUIPMENT REMOVAL &amp; INSTALLATION .....</b>	<b>6-1</b>
6.1	GDU 1054B/1050.....	6-2
6.2	GTX 335R/GTX 345R Transponder (if installed) .....	6-2
6.3	GDL 69A SXM (if installed) .....	6-3
6.4	GSU 75 ADAHRS .....	6-3
6.5	Configuration Module .....	6-4
6.6	FS 510 Wifi/Bluetooth Data Link (if installed).....	6-9
<b>7.</b>	<b>GARMIN G1000 LRU REPLACEMENT/CONFIGURATION &amp; TESTING.....</b>	<b>7-1</b>
7.1	GDU 1054B/1050 PFD & MFD.....	7-1
7.2	GTX 335R or GTX 345R Transponder .....	7-4
7.3	GDL 69A SXM Data Link (if installed).....	7-8
7.4	GSU 75 ADAHRS (if installed) .....	7-10
7.5	GSU/GMU Calibration Procedures.....	7-15
<b>8.</b>	<b>SUBSYSTEM FUNCTIONAL CHECKS .....</b>	<b>8-1</b>
8.1	FliteCharts Functional Check .....	8-1
8.2	ChartView Functional Check.....	8-2
8.3	SafeTaxi Functional Check .....	8-3
<b>9.</b>	<b>G1000 SYSTEM RETURN TO SERVICE PROCEDURE .....</b>	<b>9-1</b>
9.1	Display Test .....	9-1
9.2	Display Failure Test .....	9-4
9.3	Reversion Mode Check.....	9-5
9.4	GPS Signal Acquisition .....	9-6
9.5	GPS Failure Test.....	9-7
9.6	G1000 Backup Path Test .....	9-8
9.7	Maintenance Records .....	9-8

### LIST OF ILLUSTRATIONS

<b>FIGURE</b>	<b>PAGE</b>
Figure 2-3, GSU-75 ADAHRS with Connector and Mounting Tray .....	2-2
Figure 2-1, Flight Stream 510.....	2-2
Figure 2-2, GTX 345R/GTX 335R Transponder .....	2-3
Figure 2-3, GDL 69A SXM Datalink.....	2-3
Figure 2-4, G1000 Softkeys .....	2-4
Figure 2-5, Normal Mode .....	2-5
Figure 2-6, Automatic Reversion with MFD failure .....	2-7
Figure 3-1, SET>ACTV Diagram.....	3-2
Figure 3-2, Loss of Communication.....	3-3
Figure 3-3, Configuration Status .....	3-3
Figure 3-4, Data Transmission Indicators.....	3-3
Figure 3-5, GSU Configuration Settings Storage.....	3-12
Figure 3-5, Garmin Unit S/N Location .....	3-14
Figure 3-6, Software/Configuration Overview .....	3-15
Figure 3-7, Airframe Group Selection.....	3-17
Figure 3-8, Airframe Change Confirmation.....	3-18
Figure 3-9, MFD Aux - Database Page DB Transfer .....	3-38
Figure 3-10, Stormscope Configuration Page .....	3-40
Figure 3-11, Stormscope Configuration.....	3-40
Figure 5-1, Aux – System Status Page .....	5-1
Figure 5-2, System Annunciations.....	5-2

Figure 5-3, Alerts & Annunciations .....	5-9
Figure 5-4, Alerts Softkey Annunciation .....	5-9
Figure 5-5, Magnetometer Interference Test .....	5-20
Figure 5-5, GTX 335R/345R Looking at Front of Connector (P3251) .....	5-28
Figure 5-6, GTX 345R (Only) Looking at Front of Connector (P3252) .....	5-28
Figure 5-7, GDU 1054B/1050 Backshell Connector (P10401) .....	5-29
Figure 5-8, GDL 69A SXM Backplate Connector (P69A1) .....	5-29
Figure 5-9, GSU 75 Connector View from Front (P751) .....	5-29
Figure 6-1, Configuration Module Installation .....	6-4
Figure 6-2, Configuration Module Installation .....	6-5
Figure 6-3, GSU 75 Configuration Module Installation .....	6-6
Figure 7-1, G1000 Normal Mode Check .....	7-3
Figure 7-2, GTX Ground Test Mode Softkey .....	7-6
Figure 7-7, Normal Mode AHRS Check .....	7-14
Figure 7-5, GRS/GMU Calibration, Pitch/Roll Offset .....	7-16
Figure 7-6, GRS/GMU Calibration, Engine Run-Up .....	7-21
Figure 9-1, MFD Power Up Page .....	9-1
Figure 9-2, PFD Power-up System Annunciations .....	9-2
Figure 9-3, PFD Normal Operation .....	9-3
Figure 9-4, GDU Reversionary Mode .....	9-5
Figure 9-5, AUX-GPS Status Page .....	9-6

**LIST OF TABLES**

<b>TABLE.....</b>	<b>PAGE</b>
Table 1-1, Required Documents .....	1-4
Table 1-2, Reference Publications .....	1-5
Table 4-1, Maintenance Intervals .....	4-4
Table 5-1, SVS Troubleshooting .....	5-11
Table 5-2, SVS-Related Alert Messages .....	5-12
Table 5-3, Magnetometer Interference Test Sequence .....	5-21
Table 6-1, Configuration Module Kit – 011-00979-00 .....	6-4
Table 6-2, Configuration Module Kit – 011-00979-03 .....	6-5
Table 6-3, GSU 75 Configuration Module Kit – 011-00979-20 .....	6-6
Table 7-1, Altitude Test Points .....	7-13
Table 7-2, Airspeed Test Points .....	7-13
Table 7-3, Required GRS/GMU Calibrations .....	7-15

---

## 1. INTRODUCTION

### 1.1 Content, Scope, Purpose

This document provides Instructions for Continued Airworthiness (ICA) for the NXi configuration of the Garmin G1000 Integrated Flight Deck including the GFC700 Automatic Flight Control System (AFCS) as installed in the Textron Aviation Inc., NAV III series of aircraft, under STC SA01945WI. This document satisfies the requirements for continued airworthiness as defined by 14 CFR Part 23.1529 and 14 CFR Part 23 Appendix G. Information in this document is required to maintain the continued airworthiness of the G1000 and GFC700.

Throughout this document, the GFC 700 autopilot system is included in the G1000NXi system description and is identified separately only when needed.

References to “NAV III” throughout this document include 172R, 172S, 182T, T182T, 206H, and T206H models. Items in this document that are aircraft model(s) specific will identify the model(s) instead of “NAV III”.

This document is a supplement to the existing G1000 Nav III Line Maintenance Manual, Garmin part number 190-00352-00. Except where noted, refer to the G1000 Nav III Line Maintenance Manual for servicing instructions.

#### 1.1.1 Applicability

This document applies to all Textron Aviation Inc. NAV III aircraft equipped with the G1000NXi system as modified by this STC. All airplanes modified by this STC are configured per General Arrangement drawing 005-01474-01 Rev 2 or subsequent.

Modification of an aircraft by this Supplemental Type Certificate (STC) obligates the aircraft operator to include the maintenance information provided by this document in the operator’s Aircraft Maintenance Manual.

#### 1.1.2 Identifying an STC Configuration

The General Arrangement drawing lists the G1000 System Software Version numbers approved for this STC.

#### **IMPORTANT!**

**If the technician is unsure of an aircraft’s STC configuration, perform the following:**

After acknowledgement of the splash screen, use the FMS knob to go to the **Aux – System Status** page on the MFD. In the AIRFRAME section (upper right corner,) the display shows the current G1000NXi airframe configuration and system software version number. The airframe configuration is shown in the Airframe field and the system software version number is shown in the following format: ‘SYS SOFTWARE VERSION XXXX.XX’. It correlates to the software image used to load the software to the system:

#### **EXAMPLE:**

System Software Version ‘**4013.01**’ = Software Image P/N **006-B4013-01**

---

## 1.2 Organization

The following outline briefly describes the organization of this manual:

Section 2: System Description

Provides a description of the type design change associated with installing the G1000 update in the Cessna Nav III Series.

Section 3: Software and Configuration

Provides software and configuration loading instructions for a complete system software load.

Section 4: Instructions for Continued Airworthiness

Provides maintenance instructions for continued airworthiness of the G1000 system.

Section 5: Troubleshooting

Provides troubleshooting information to aid in diagnosing and resolving potential problems with the G1000 system.

Section 6: Equipment Removal & Installation

Gives instructions for the removal and replacement of G1000 equipment.

Section 7: Garmin G1000 LRU Replacement/Configuration & Testing

Gives instructions for loading software, configuring, and testing of G1000 equipment.

Section 8: Subsystem Functional Checks

Gives instructions for testing G1000 subsystems.

Section 9: G1000 System Return to Service Procedure

Specifies return-to-service procedures to be performed upon completion of maintenance of the G1000 system.

---

### 1.3 Definitions/Abbreviations

ADC:	Air Data Computer
ADF:	Automatic Direction Finder
ADS-B:	Automatic Dependent Surveillance – Broadcast
AFCS:	Automatic Flight Control System
AFMS:	Airplane Flight Manual Supplement
AHRS:	Attitude Heading Reference System
AML:	Approved Model List
CDU:	Control Display Unit
CFR:	Code of Federal Regulations
DME:	Distance Measuring Equipment
FIS-B:	Flight Information Services – Broadcast
FS:	Flight Stream™
GPS:	Global Positioning System
HSDB:	High-Speed Data Bus (Ethernet)
ICS:	Inter-Com System
LRU:	Line Replaceable Unit
MFD:	Multi-Function Display
MMC:	Multi-Media Card
OAT:	Outside Air Temperature
PFD:	Primary Flight Display
STC:	Supplemental Type Certificate
TAWS:	Terrain Awareness & Warning System
TIS-B:	Traffic Information Services – Broadcast
VHF:	Very High Frequency

## 1.4 Units of Measure

Unless otherwise stated, all units of measure are English units.

## 1.5 Publications

The following documents are required by this maintenance manual to perform maintenance. It is the responsibility of the owner / operator to ensure latest versions of these documents are used during operation, servicing or maintenance of the airplane.

**Table 1-1, Required Documents**

<b>Part Number</b>	<b>Garmin Document</b>
005-01474-00	Master Drawing List, G1000 Avionics Updates, Part 23 AML STC
005-01474-01	General Arrangement, G1000 Update, Textron NAV III
005-01474-09	Forward Avionics Install G1000 NXi, 172R/172S
005-01474-10	Forward Avionics Install G1000 NXi, 182T/T182T
005-01474-11	Forward Avionics Install G1000 NXi, 206H/T206H
005-01474-13	Remote Avionics Install G1000 NXi, 172R/172S
005-01474-14	Remote Avionics Install G1000 NXi, 182T/T182T
005-01474-15	Remote Avionics Install, G1000 NXi, 206H/T206H
005-W0047-01	Wiring Diagram, G1000 NXi, GTX3X5 Textron 172, 182, 206
005-01474-17	Wire Harness Install/Routing, Textron 172R/172S
005-01474-18	Wire Harness Install/Routing, Textron 182T/T182T
005-01474-19	Wire Harness Install/Routing, Textron 206H/T206H
<b>Part Number</b>	<b>Textron Aviation Documents</b>
C172RMM	Model 172R/172S Maintenance Manual
C182SMM	Model 182S/182T/T182T Maintenance Manual
C206HMM	Model 206H/T206H Maintenance Manual
C172RWD	Cessna Model 172 (Series 1996 and On) Wiring Diagram Manual
C182SWD11	Cessna Model 182 (Series 1997 and On) Wiring Diagram Manual
C206HWD	Cessna Model 206 (Series 1998 and On) Wiring Diagram Manual
SESR	Single Engine Structural Repair Manual – 172, 182, 206 Series

---

The following publications are recommended to be on hand during the performance of maintenance activities.

**Table 1-2, Reference Publications**

<b>Part Number</b>	<b>Garmin Document</b>
190-02765-02	Airplane Flight Manual Supplement, G1000 NXi Integrated Avionics System and GFC 700 AFCS In Textron NAV III Series of aircraft
190-02765-00	G1000 NXi System Post Installation Checkout Procedure, Textron 172R/172S, 182T/T182T, 206H/T206H
190-02765-04	G1000 NXi Supplemental Maintenance Manual, Textron Aviation Inc. Nav III Aircraft, includes Instructions for Continued Airworthiness for STC SA01945WI
190-02824-00	Cockpit Reference Guide, G1000 NXi Cessna NAV III, SSV 4013.00 or later
190-00355-04	GDL 69 Series SiriusXM Satellite Radio Activation Instructions
190-00352-00	G1000 NAV III Line Maintenance Manual

Generic installation manuals for individual Garmin LRUs are also available through the 'Dealer Resource Center' section of the Garmin web site; refer to Section 1.6 for details.

## **1.6 Revision and Distribution**

This document is required for maintaining the continued airworthiness of the aircraft. When this document is revised, every page will be revised to indicate current revision level.

Garmin Dealers may obtain the latest revision of this document on the Garmin Dealer Resource Center website.

Owner/operators may obtain the latest revision of this document from the <https://fly.garmin.com/Support> page, or by contacting a Garmin dealer, contacting Garmin Product Support at 913-397-8200, toll free 866-739-5687, or using around the world contact information on <https://fly.garmin.com/>.

A Garmin Service Bulletin describing the revision to this document will be sent to Garmin dealers if the revision is determined to be significant.

---

## 2. SYSTEM DESCRIPTION

### 2.1 Equipment Descriptions

For description of equipment and functions not listed here, refer to the G1000 Nav III Line Maintenance Manual, Garmin part number 190-00352-00.

#### 2.1.1 GDU 1054B OR GDU 1050 PFD & MFD

Two Garmin GDU 1054B or GDU 1050 displays are installed in the Nav III instrument panel. The GDU 1054B displays are standard equipment on all Nav III models, while the GDU 1050 displays are installed on Model 172 aircraft that are not equipped with the Garmin GFC700 autopilot.

The GDU 1054B or GDU 1050 displays are 10.4 inch LCD displays with 1024 x 768 resolution.

The GDU 1054B or GDU 1050 units communicate with each other and the GIA units through a high-speed data bus (HSDB) Ethernet connection.

The PFD receives primary electrical power from the Essential Bus and secondary electrical power from Avionics Bus No. 1. The MFD receives electrical power from Avionics Bus No. 2. The displays will power-up immediately with external or aircraft power or battery operation.

All displays are installed in the panel using ¼-turn fasteners.

#### 2.1.2 GSU 75 ADAHRS

The GSU 75 ADAHRS is a combined Air Data and AHRS system. The unit is mounted in the tail avionics area. It contains advanced tilt sensors, accelerometers, rate sensors, static pressure sensors, and pitot pressure sensors. The GSU 75 receive GPS data from the GIA 63Ws, and magnetic heading from the GMU 44 Magnetometer.

The GSU receives primary electrical power from the Essential Bus and a secondary power supply from Avionics Bus 1. The GSU provides electrical power to the onside GMU 44 Magnetometer and the GTP 59 OAT probe.

The GSU connects to the existing pitot/static ports.

Each GSU 75 provides the following information via ARINC 429 busses to both GIAs, the PFD and the MFD.

- Aircraft altitude and airspeed
- Aircraft vertical speed, Mach and outside air temperature
- Aircraft heading, pitch and roll
- Aircraft yaw, pitch and roll rates
- Aircraft body-axis accelerations
- Rates of change of heading, pitch and roll
- Aircraft accelerations expressed in a local level frame of reference



**Figure 2-1, GSU-75 ADAHRS with Connector and Mounting Tray**

### **2.1.3 Flight Stream 510**

The Flight Stream™ 510 (FS 510) is a Wi-Fi/Bluetooth capable multi-media card (MMC) installed the bottom SD slot of the MFD. It sends position, velocity, time, attitude, heading, FIS-B, TIS-B traffic, Sirius XM audio control, Sirius XM weather data, and flight plan transfer to mobile devices via Bluetooth. The FS 510 can also interface with a mobile device via Wi-Fi pairing for the purposes of updating databases used by the GDU(s). Bluetooth and Wi-Fi are mutually exclusive with only one interface functional at a time. Connecting via Wi-Fi requires a pilot-configurable Wi-Fi Protected Access WPA2 security password. By updating databases wirelessly, new databases may be transferred to the G1000 system without a data card.



**Figure 2-2, Flight Stream 510**

---

#### 2.1.4 GTX 345R / GTX335R Transponder

The Garmin GTX 345R or GTX 335R transponders communicate with the GIAs through RS-232 digital interface.

The GTX 345R also communicates with the G1000 Avionics through an HSDB interface connected to the PFD. When installed, the GTX 345R communicates and controls the GTS Processor through the HSDB interface for all TAS operations. The GTX 345R mixes and coordinates the TAS targets with TIS-B and ADS-B targets to provide one coordinated traffic display to the crew.

The transponder units are mounted in the tail section of the aircraft.

Power is provided to the GTX from the Avionics Bus #2. The GTX transponder interfaces with a transponder antenna mounted to the bottom of the fuselage.



Figure 2-3, GTX 345R/GTX 335R Transponder

#### 2.1.5 GDL 69A SXM Datalink

The GDL 69A SXM provides SiriusXM Radio weather and music entertainment through means of a dedicated satellite data link. The GDL 69A SXM is mounted behind the instrument panel in the 182 and 206 models and in the aft avionics area for 172 models. Power to the GDL 69A SXM is received from the Avionics No. 1 bus. The GDL 69A SXM sends weather data through the HSDB bus to the MFD, where the data link interface is controlled. Audio is sent directly to the GMA Audio Panel.



Figure 2-4, GDL 69A SXM Datalink

---

## 2.2 G1000 Optional Interfaces

There are no new optional interfaces approved as part of this STC. Refer to the G1000 Nav III Line Maintenance Manual for optional interfaces.

## 2.3 Electrical Power Distribution

The electrical power distribution has not changed as a result of this STC. Refer to the G1000 Nav III Line Maintenance Manual for power distribution.

## 2.4 Pitot/Static System

The layout of the pitot/static system has not changed as a result of this STC.

## 2.5 GDU 1054B and GDU 1050 Displays

The location and function of the controls on the GDU 1054B or GDU 1050 displays are unchanged from those described for the GDU 1040 or GDU 1044B in the G1000 Nav III Line Maintenance Manual.

## 2.6 Softkeys

Some pages have commands or selections that are activated by the GDU 1054B or GDU 1050 softkeys. If a softkey is associated with a command, that command will be displayed directly above the key. A grayed-out softkey shows a command that is unavailable. A softkey that is highlighted (green bar) shows the current active selection.



Figure 2-5, G1000 Softkeys

## 2.7 FMS Knob

The FMS knob is the primary control for the G1000 system.

To cycle through different configuration screens:

*To change page groups:* Rotate the large FMS knob.

*To change pages in a group:* Rotate the small FMS knob.

To activate the cursor for a page, press the small FMS knob directly in, as one would push a regular button.

To cycle the cursor through different data fields, rotate the large FMS knob.

To change the contents of a highlighted data field, rotate the small FMS knob. This action either brings up an options menu for the particular field, or in some cases allows the operator to enter data for the field.

To confirm a selection, press the **ENT** key.

To cancel a selection, press the small FMS knob in again, deactivating the cursor. The **CLR** key may also be used to cancel a selection or deactivate the cursor.

## 2.8 G1000 Normal Mode

To start the G1000 system in Normal Mode:

1. With a ground power unit connected to the external power receptacle, turn ON the BAT (battery) switch. The following G1000 equipment is powered on:
  - PFD display
  - GDC & GRS (If installed)  
OR
  - GSU ADAHRS (if installed)
  - GIA #1 (NAV and COM)
  - GEA Engine/Airframe Unit
2. Turn ON the AVIONICS BUS 1 and AVIONICS BUS 2 switches. The following G1000 equipment is powered on:
  - PFD (secondary power)
  - MFD
  - GDC/GRS (secondary power) – if installed  
OR
  - GSU ADAHRS (secondary power) – if installed
  - GIA #1 (NAV) (secondary power)
  - GEA Engine/Airframe Unit (secondary power)
  - GTS 800 Traffic System (if installed)
  - GTX Mode S/ADS-B Transponder
  - GIA #2 (NAV and COM)
  - GMA Audio Panel
  - GSA Servos

The G1000 system is now powered in the normal mode. In the normal operating mode, data fields that are invalid have large red X's through them. A valid field does not display a red X. Allow the displays to initialize for approximately one minute for the red X's to be removed.

The PFD and MFD will function as specified in the G1000 Cockpit Reference Guide when the system has been correctly installed and configured.



Figure 2-6, Normal Mode

## 2.9 Reversionary Mode

Reversionary mode allows for display of information related to safe flight in the event of a display communication or hardware failure. The PFD automatically goes into reversionary mode when communication to the MFD is lost. Manual reversionary mode allows the operator to force the PFD and MFD into reversionary mode by pressing the large red button labeled 'DISPLAY BACKUP' on the GMA audio panel.

### NOTE

When the 'DISPLAY BACKUP' button is pushed to exit reversionary mode, there is a 5-second delay until the display returns to normal mode. If the 'DISPLAY BACKUP' button is pushed again during this 5-second delay, the display will reset the five second delay timer.



Figure 2-7, Automatic Reversion with MFD failure

---

### 3. Software and Configuration

#### 3.1 Configuration Mode Overview

Throughout this document, references are made to the PFD and/or MFD being in configuration mode. The configuration mode exists to provide the avionics technician with a means of configuring, checking, and calibrating various G1000 sub-systems. Troubleshooting and diagnostics information can also be viewed in this mode.

To start the G1000 system in configuration mode, follow these steps:

1. Apply power to the G1000 system by applying aircraft EXT power, selecting the BAT MASTER and AVIONICS BUS 1 and AVIONICS BUS 2 switches to ON.
2. Pull the MFD, PFD (ESS BUS), and PFD (AVN BUS 1) circuit breakers.
3. Press and hold the ENT key on the MFD while applying power using the MFD circuit breaker.
4. Release the ENT key after 'INITIALIZING SYSTEM' appears in the upper left corner of the MFD.
5. Press and hold the ENT key on the PFD while applying power using the PFD (ESS BUS) circuit breaker.
6. Release the ENT key after 'INITIALIZING SYSTEM' appears in the upper left corner of the PFD.

#### CAUTION:

Configuration Mode contains certain pages and settings that are critical to aircraft operation and safety. These pages are protected and cannot be modified, unless the technician is properly authorized and equipped. However, most protected pages are viewable to allow system awareness for troubleshooting.

#### NOTES

If the specific procedure requires an SD card to be in the top slot of the PFD/MFD, this card must be inserted prior to applying power to the PFD/MFD. Any time a card is inserted, the power to the PFD/MFD must be cycled.

For a complete description and breakdown of each Configuration Mode page, refer to the G1000 System Maintenance Manual listed in Table 1-2.

##### 3.1.1 SET>ACTV Configuration

Throughout the configuration mode pages, there are SET and ACTIVE columns for input/output settings and other parameters.

**SET:** Refers to a setting or group of settings that reside in PFD Internal Memory and/or the Master Configuration Module.

**ACTIVE:** Refers to an 'active' setting or parameter currently being used by the LRU. LRUs store the 'active' settings within internal memory.

Data can be manually copied from one column to the other (and consequently from PFD memory to the LRU memory and vice-versa) by using the following two softkeys, when available:

- SET>ACTV (read 'Set to Active') softkey: Allows the installer to send the information in the SET column (data stored in the master config module) to the ACTV column (data used by LRU).

- ACTV>SET (read 'Active to Set') softkey: Causes the LRUs current settings to be copied to the master configuration module as SET items.

**CAUTION:**

**The ACTV>SET softkey must be used with caution! If an improperly configured unit is installed, this softkey causes the wrong configuration to replace the correct aircraft configuration.**

In the first example shown in Figure 3-1 the SET columns do not match the ACTIVE columns. The inequality between SET and ACTIVE indicates a configuration mismatch. By pressing the SET>ACTV softkey, this copies the SET column to the LRU unit's configuration memory. The settings then become the ACTIVE settings for the LRU being configured.

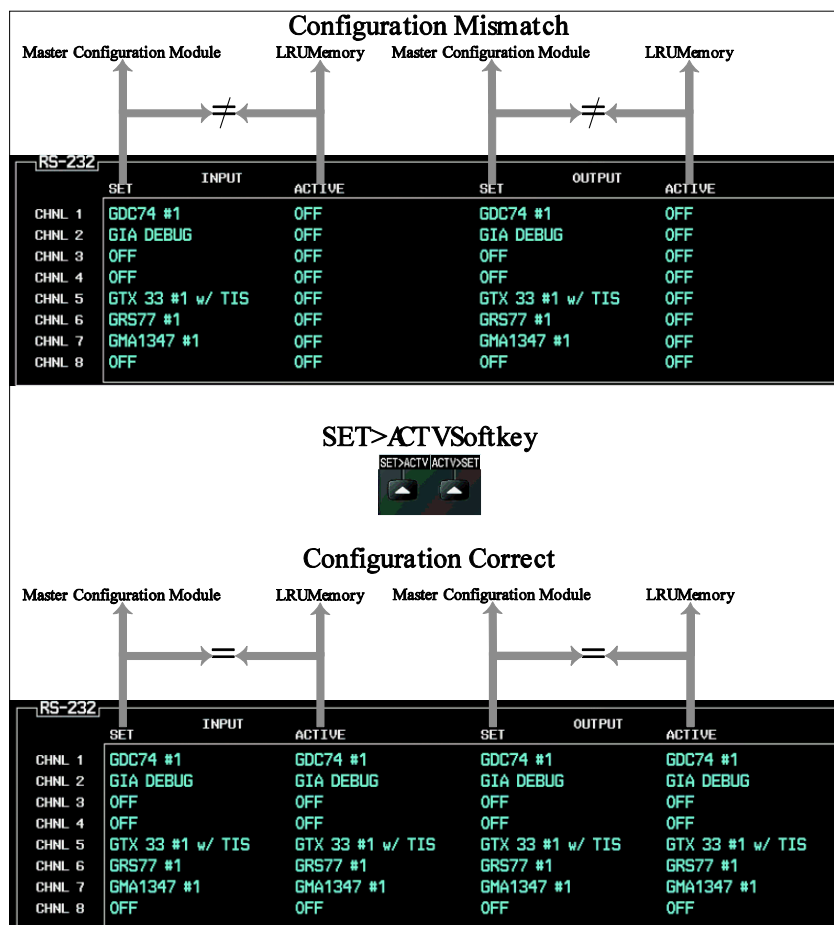

**Figure 3-1, SET>ACTV Diagram**

When troubleshooting the system, technicians can look for inequalities between SET and ACTIVE columns. Certain problems can be resolved simply by pressing the SET>ACTV softkey, which reloads settings to the specific LRU from the PFD. (Note that this can also be accomplished by reloading the configuration files for the LRU. Section 7 describes this process for each LRU).

A blank active column, as shown in Figure 3-2, represents loss of communication between the display and the particular unit. See Section 5 for more details on troubleshooting.

RS-232		INPUT		OUTPUT	
CHANNEL	SET	ACTIVE	SET	ACTIVE	
CHNL 1	GDC74 #1		GDC74 #1		
CHNL 2	GIA DEBUG		GIA DEBUG		
CHNL 3	OFF		OFF		
CHNL 4	OFF		OFF		
CHNL 5	GTX 33 #1 w/ TIS		GTX 33 #1 w/ TIS		
CHNL 6	GRS77 #1		GRS77 #1		
CHNL 7	GMA1347 #1		GMA1347 #1		
CHNL 8	OFF		OFF		

**Figure 3-2, Loss of Communication**

### 3.1.2 Configuration Prompts

When configuration settings are changed, the technician receives on-screen prompts and/or confirmations such as those shown in Figure 3-3.



**Figure 3-3, Configuration Status**

### 3.1.3 Data Transmission Indicators

Several configuration screens utilize an indicator light system to show discrete (ON/OFF) data and/or hardware component status. Unless otherwise noted, the following applies to all such status indicators:

- Green Checkmark: Expected data is successfully received and is ON. A green check could also indicate that the parameter/component is working correctly.
- Red X: Expected data is not received. A red X could also indicate that a parameter/component is invalid.
- White N/A: Expected data is OFF, or no data is expected.

STATUS				GDU STATUS			
RAM	✓	XILINX®	✓	BASE MAP	✓	ETHERNET 4	✗
ETHERNET 1	✗	ETHERNET 2	✗	ETHERNET 3	✗		
RS-232 1	✗	RS-232 2	✗	IRDA	✗		

**Figure 3-4, Data Transmission Indicators**

### 3.1.4 Configuration Mode Navigation

Using the FMS knob as described in Section 2.7, a user can navigate through different pages and page groups in the Configuration Mode. For complete description and breakdown of each page, refer to the G1000 System Maintenance Manual listed in Table 1-2. Pages below will be shown only for the units/options installed on the aircraft.

<b>System Page Group</b>		
1. System Status	7. Transaction Log	13. System Setup
2. Time Configuration	8. Aircraft Configuration	14. Manifest Configuration
3. Lighting Configuration	9. Diagnostics Terminal	15. Maintenance Log
4. System Audio	10. OEM Diagnostics	16. Configuration Manager
5. System Upload	11. System Configuration	
6. LRU Replacement	12. System Data Path Configuration	
<b>GDU Page Group</b>		
1. Serial Configuration	6. Diagnostics	11. Airframe Configuration
2. CDU Status Page	7. Ethernet Test	12. TAWS Configuration
3. Key Test	8. Video Test	
4. FS 510 Test	9. Alert Configuration	
5. CDU Calibration	10. DAT Configuration	
<b>GIA Page Group</b>		
1. Serial Configuration	3. GIA I/O Configuration	5. GIA Status Page
2. GIA RS-485 Configuration	4. GIA COM Setup Page	6. GIA CAN Configuration
<b>GEA Page Group</b> (for GEA 71 only)		
1. Engine Configuration	2. GEA Status Page	3. GEA Configuration
<b>GTX Page Group</b> (for GTX 33 only)		
1. Serial Configuration	2. Transponder Configuration	
<b>GTX 3X5 Page Group</b> (for GTX 335R, GTX 345R only)		
1. Transponder Airframe Config	2. Transponder Wiring Config	3. Transponder Diagnostics
Note: This configuration page is not shown unless software loader card is installed in upper slot of PFD1.		
<b>GRS Page Group</b>		
1. Inputs Configuration	3. GRS Flight Data Log	
2. GRS / GMU Calibration		
<b>ADC Page Group</b>		
1. ADC Configuration	2. GDC Configuration	
<b>GFC Page Group</b>		
1. GFC Configuration	2. GFC Status	
<b>GMA Page Group</b> (for GMA 1347 only)		
1. GMA Configuration		
<b>GDL Page Group</b>		
1. GDL 69 Configuration		
<b>GTS Page Group</b>		
1. GTS Configuration		

---

**OTHER Page Group**

1. Stormscope

**CAL Page Group**

1. Fuel Tank Calibration
2. Flaps & Trim Calibration
3. HSCM Calibration
4. DAT Calibration

### 3.2 G1000 System Software Information

#### NOTE

The following sections provide a detailed description of loading all G1000 software and configuration files, which may be excessive for individual LRU removal and replacement. If removing and replacing individual LRUs, refer to Section 6 of this manual for the necessary steps.

#### 3.2.1 G1000 Software Image

All software and configuration files were certified by Garmin and are considered part of FAA-approved Type Design data. Approved software and hardware definitions for each STC Configuration are defined on the appropriate General Arrangement drawing listed in Table 1-1.

G1000 software and configuration files are controlled via the approved software image part number listed on the General Arrangement drawing listed in Table 1-1. This software image is loaded into the G1000 using a software loader card. The installer shall create this software loader card by downloading the approved software image in accordance with Section 3.2.2.

#### NOTE

Only SanDisk brand SD cards are recommended for use with the G1000 system. Other brand cards have not been tested by Garmin.

#### NOTE

Installers may obtain the software image already on a loader card by ordering the loader card directly from Textron Aviation. Reference the General Arrangement drawing 005-01474-01 for loader card part number information.

#### **IMPORTANT!**

**To satisfy the G1000/GFC700 STC requirements for the Nav III aircraft, it is critical that the technician install correct software image part number when servicing the G1000 system.**

**Approved software image part numbers are defined on the appropriate General Arrangement drawing (see Table 1-1).**

#### **CAUTION:**

Be cautious when using software loader cards during maintenance. The G1000 system immediately initializes the card upon power-up. On-screen prompts must be given careful attention in order to avoid potential loss of data. Always read through procedures given in this manual before attempting to use the software loader cards.

### 3.2.2 Loader Card Creation

The software image is an executable self-extracting file which builds the correct file structure onto an SD card for use loading software to the G1000 System. To obtain the current file follow the procedures outlined below.

#### **NOTE**

In order to create a Textron Nav III system loader card, the installer completing these procedures must be an authorized Garmin Service Center to gain access to the necessary data via the Garmin website.

1. Go to [www.garmin.com](http://www.garmin.com) and click on the [Dealer Resource Center](#) link in the lower portion of the home page. Enter your Garmin Dealer username and password.



The screenshot shows the 'Dealer Resource Center' sign-in page. On the left is a 'Sign In' box with fields for 'Username' (containing 'username@mail.com') and 'Password'. Below these fields is a link to the 'Garmin Confidentiality Agreement' and a blue 'Sign In' button, with a 'Reset Password' link below it. The main content area has the heading 'Dealer Resource Center' and a welcome message. It lists resources available after signing in: product pricing, marketing materials, merchandising catalogs, manuals, Service & Installation Bulletins, and software downloads. A link for 'Contact Us' is provided for password assistance.

2. Select **Support** button then select **Software Downloads**.

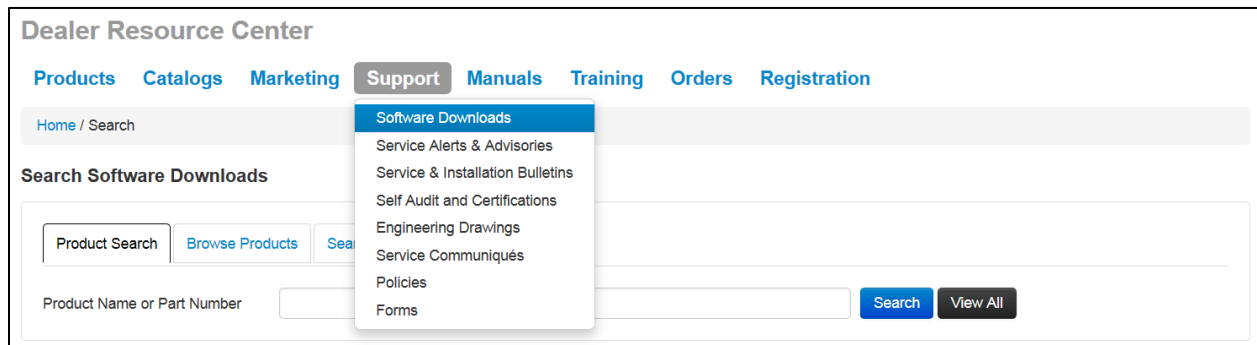

The screenshot shows the 'Dealer Resource Center' navigation menu. The 'Support' button is highlighted, and a dropdown menu is open, showing 'Software Downloads' as the selected option. Other items in the dropdown include Service Alerts & Advisories, Service & Installation Bulletins, Self Audit and Certifications, Engineering Drawings, Service Communiqués, Policies, and Forms. The background shows the main navigation bar with links for Products, Catalogs, Marketing, Support, Manuals, Training, Orders, and Registration. Below the navigation bar is a search area for software downloads with a 'Product Search' field and a 'Search' button.

- In the **Product Search** tab, type Cessna in the **Product Name or Part Number** box, then select the appropriate system and then press the **Search** button.
- A screen similar to the one shown below will appear. The numbers shown are for example only.

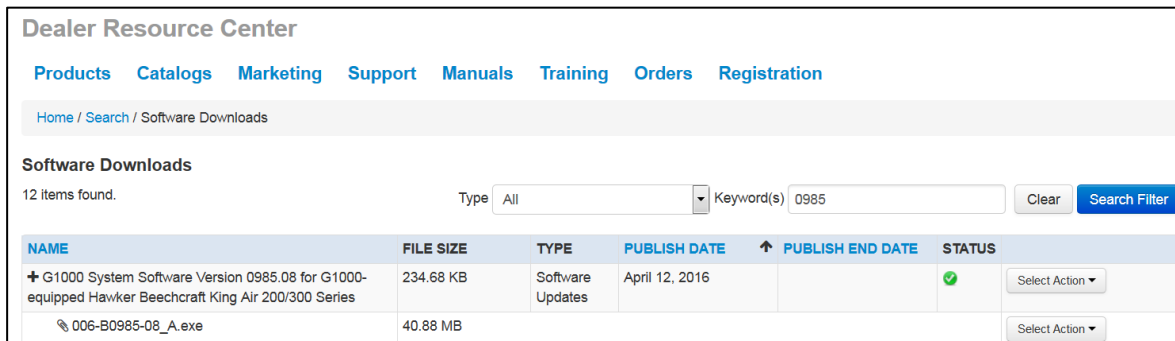

- Click on the **Select Action** button for the appropriate software image part number as shown on the Garmin General Arrangement drawing 005-01474-01 and choose **Download** to save the software file to the local hard drive.

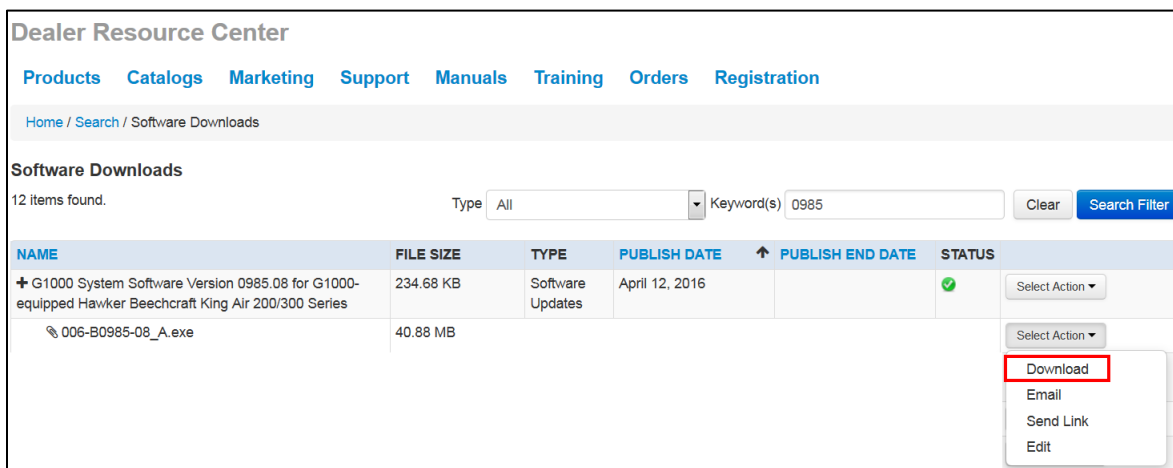

- After the file is downloaded, close the web browser.
- Insert a blank (empty) SD card in the card reader. The loader card program will delete all files on the SD card before loading G1000 system software files on it if the card is not blank.
- Double-click** the .exe file that was downloaded onto the local hard drive. The following window will pop-up on the screen. Click **Yes** to continue.

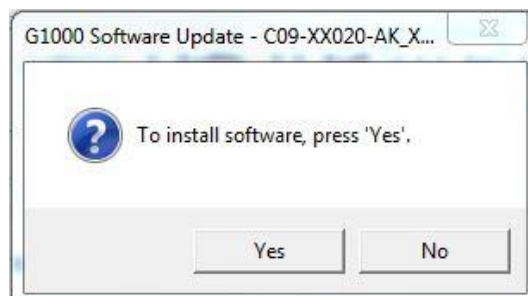

9. Follow the on screen prompts to continue.



10. Check the "I accept the terms of the License Agreement" checkbox.

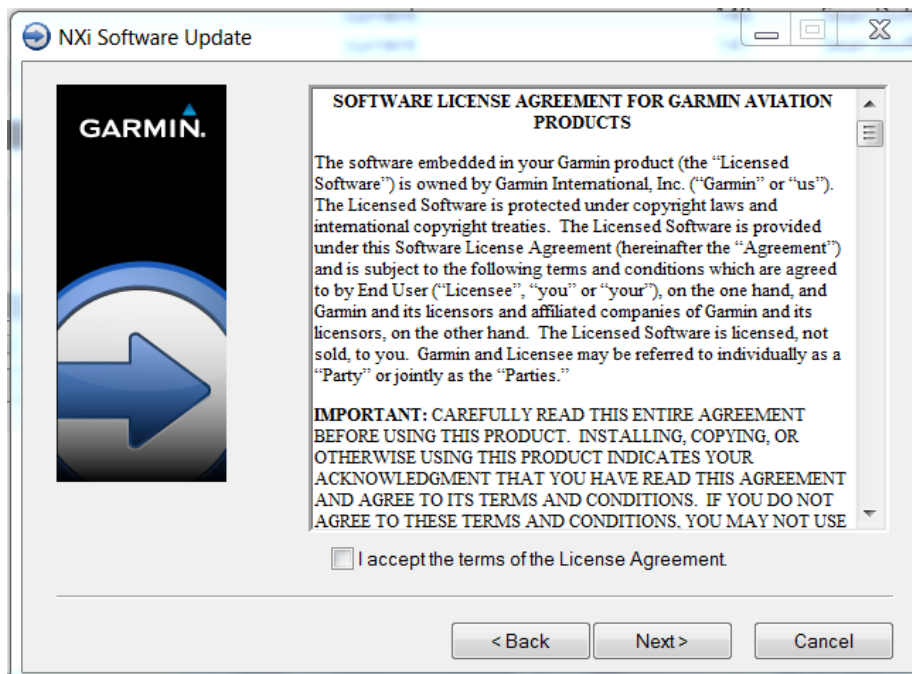

11. Select the SD card reader drive and click **Next>**.

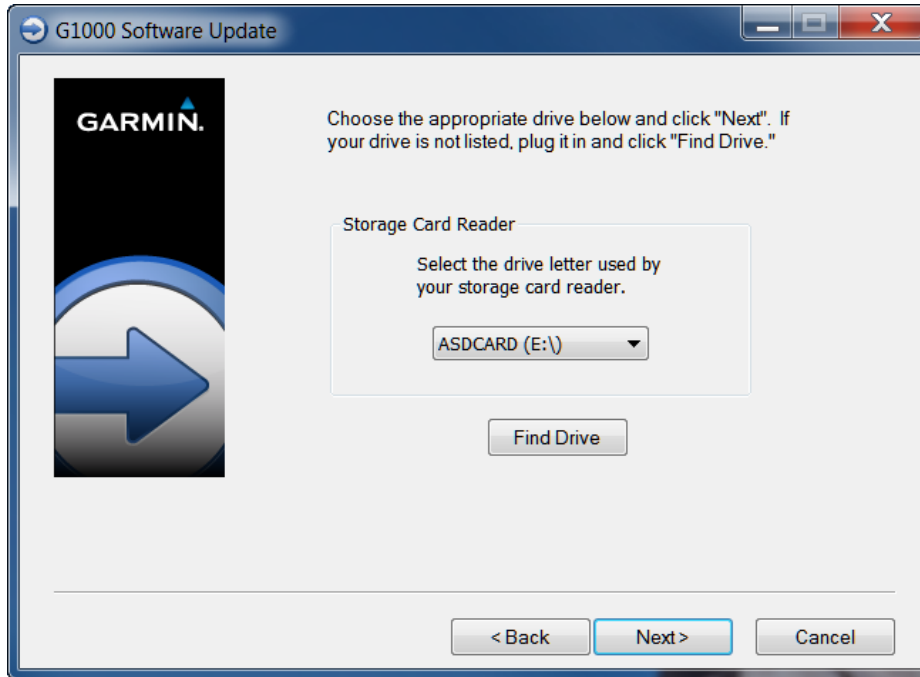

12. Follow the on screen prompts to continue.

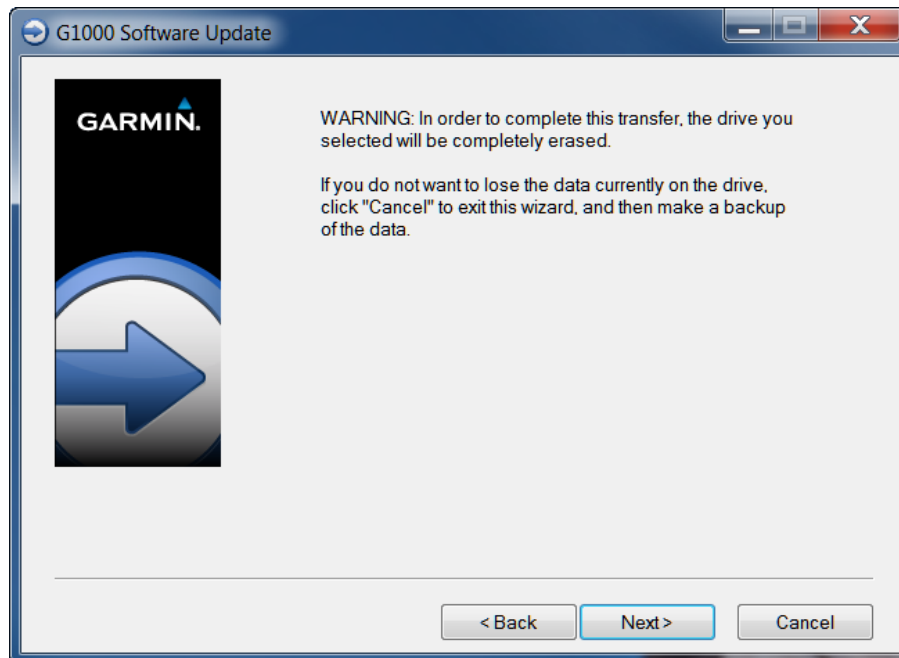

13. The program will make the SD loader card and prompt you when it's done.

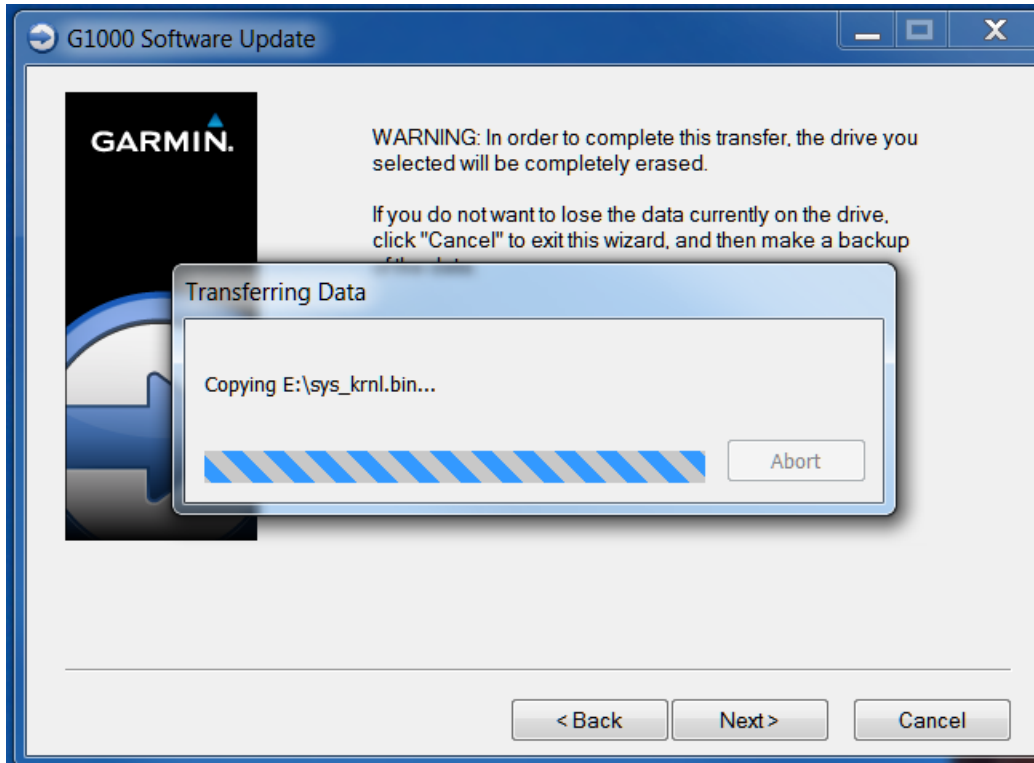

14. Once successfully completed, the following window will display. Click **Finish** to close the program. The SD card can then be removed from the computer and is ready for use in the aircraft.

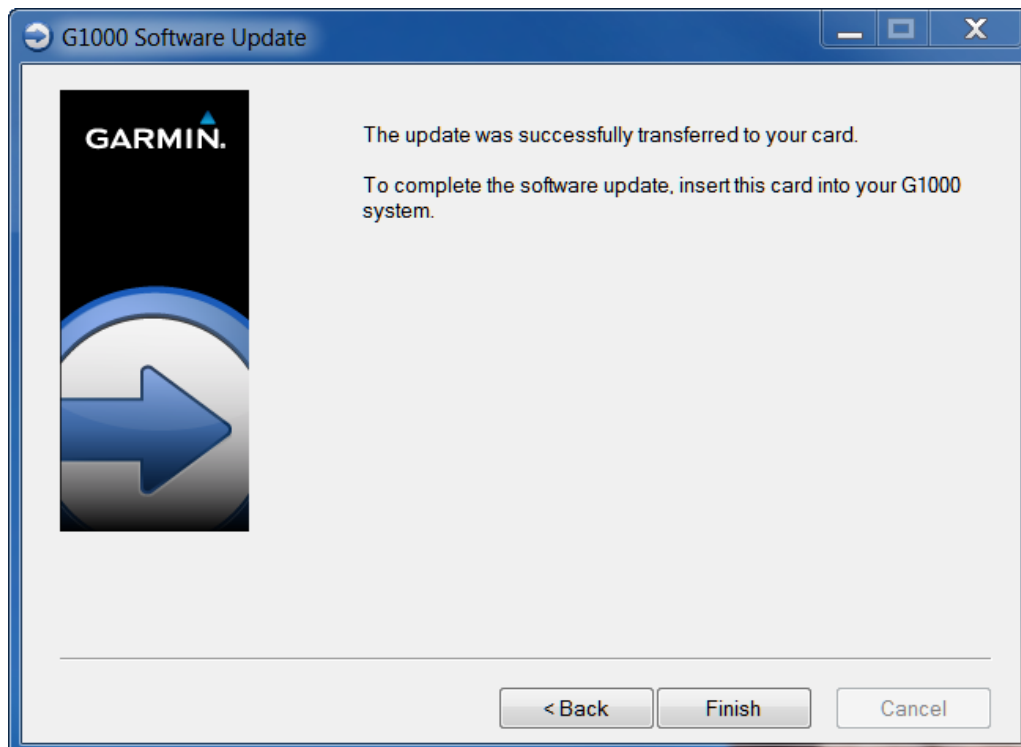

---

### 3.2.3 Software Files

Software files are defined by part number and version number on the General Arrangement drawing. Each G1000 system LRU reports the software version it currently contains to the user in two places.

- Normal System Mode: The **Aux – System Status** page lists each LRU and the reported software version.
- Configuration Mode: The **System Status** page (System page group) reports more detailed LRU information, including software version, part number, and LRU status.

Software files are loaded to LRUs from the PFD System Upload page in configuration mode.

### 3.2.4 Configuration File Descriptions

There are configuration files for baseline settings and various options. Configuration files contain preset selections for input/output channels, aircraft-specific settings, and LRU-specific settings.

#### **IMPORTANT!**

**Certain software and configuration files are REQUIRED to be re-loaded during maintenance that involves removal and replacement of G1000 equipment.**

**Refer to Section 7 for re-configuration requirements for each individual G1000 LRU. Pay special attention to the selection of option files for the units to assure a complete load.**

### 3.2.5 Configuration File Storage

The storage of G1000 system configuration files is unchanged from that depicted in the G1000 Nav III Line Maintenance Manual, except as noted in Figure 3-5 if the GSU 75 is installed.

The GSU 75 ADAHRS air data configuration file is loaded directly to GSU 75 internal memory. A copy of the file is stored in the GSU 75 configuration module. The GSU also stores AHRS calibration data acquired during the post installation checkout, which is characteristic to the specific installation. A copy of this calibration data is stored in the GSU configuration module. While performing maintenance on this unit, re-calibration may be required. See Section 7.5 for more information on re-calibration criteria.

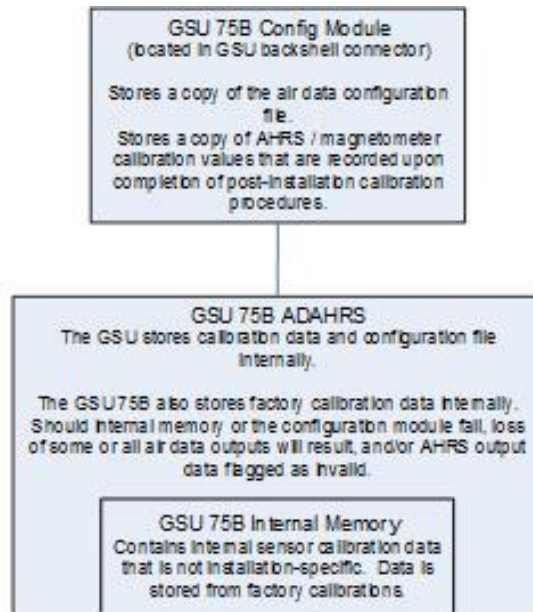

**Figure 3-5, GSU Configuration Settings Storage (if GSU installed)**

### 3.3 Configuration Mode

Throughout this document, references are made to the PFD and/or MFD being in configuration mode. To start the G1000 system in configuration mode, follow these steps:

1. With the G1000 system off, open the MFD, PFD (ESS BUS), and PFD (AVN BUS 1) circuit breakers.
2. Connect external power to the aircraft and energize the aircraft and avionics electrical busses.
3. Press and hold the **ENT** key on the MFD and close the MFD circuit breaker.
4. Release the **ENT** key after 'INITIALIZING SYSTEM' appears in the upper left corner of the MFD.
5. Press and hold the **ENT** key on the PFD and close the PFD (ESS BUS) and PFD (AVN BUS 1) circuit breaker.
6. Release the **ENT** key after 'INITIALIZING SYSTEM' appears in the upper left corner of the PFD.

---

### 3.4 G1000 Hardware/Software Compatibility Check

Before installing software, the technician must first ensure that hardware part numbers are compatible with the G1000 system software image that is to be used. The General Arrangement drawing shows all available combinations of hardware and software part numbers.

A G1000 system loader card is required to install software and configuration settings to a newly installed G1000 system. The part number of the software image used to create the loader card is directly associated with the combination of software file part numbers and version levels that are defined on the General Arrangement drawing. Should software part numbers or versions change, a new software image part number is issued.

#### **IMPORTANT**

After verifying hardware/loader card compatibility, record the software image part number and all LRU hardware part numbers in the appropriate aircraft records before proceeding.

#### **NOTE**

Throughout the next section of this document, screen shots and examples are used to illustrate the software and configuration loading process. These screen shots are provided as reference only. Always refer to the General Arrangement drawing for the correct software file names, versions and part numbers.

### 3.5 Equipment Verification (Third Party/Optional Equipment Documentation)

It is extremely important to know exactly what equipment the aircraft is equipped with before loading any files. Loading the incorrect files could lead to longer down time and unplanned removal of equipment.

- Garmin optional equipment (i.e., GSU 75, GTX 3X5R transponder, etc.). Section 3.5.1 helps find which units are installed without a physical inspection.
- Third party avionics equipment interfaced to G1000 (ADF, DME, non-Garmin traffic systems, WX-500, etc.). To determine if the third party equipment is installed, check the circuit breaker panel for circuit breakers for the units, and check for G1000 controls for the third party devices.

#### 3.5.1 Determining Installed Garmin Units

Use the table in Appendix A to determine what the unit part number is based on the unit's serial number reported on the MFD Aux - System Status page in Normal mode or PFD System Status page in Config mode. The table lists the units that have different loader card option files so the installer can choose the correct file without requiring the unit to be physically inspected.

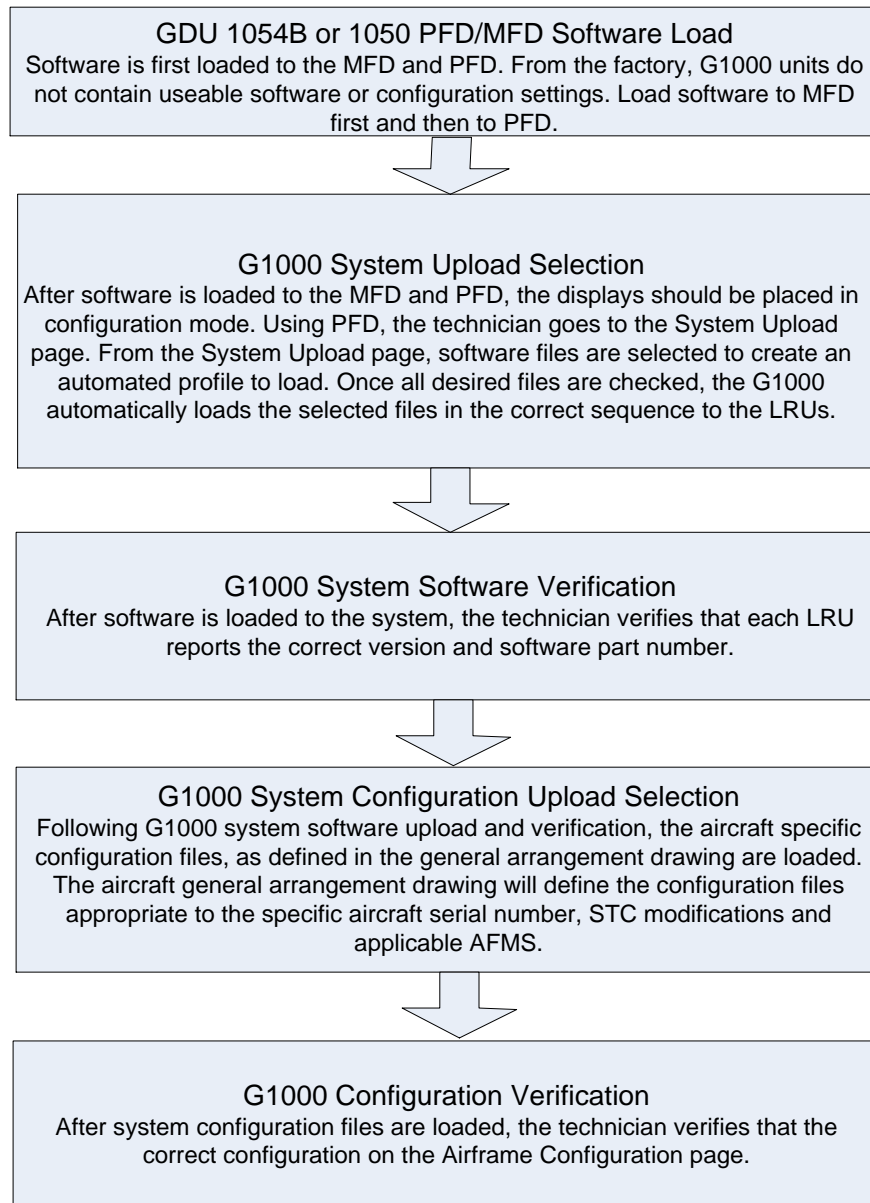

Figure 3-6, Garmin Unit S/N Location

### 3.6 G1000 Software/Configuration Procedure

This section summarizes the procedures required to load software and configuration files to the G1000. It is intended to work as a central guide for technicians to use while performing maintenance on the aircraft. In sections of this manual where software is required to be reloaded, these sections will refer back to this section for instructions. The technician should use proper judgment regarding the context of maintenance required while following this section.

The following diagram depicts an overview of the software/configuration sequence for the G1000 system. This applies mostly to a new G1000 system software installation by Service Bulletin and is for informative purposes only.



**Figure 3-7, Software/Configuration Overview**

---

### 3.7 System Software and Configuration Load

#### 3.7.1 System Power Up

Apply power to the G1000 system by connecting external power to the aircraft to energize the aircraft and avionics electrical busses.

**DO NOT RELY ON THE AIRCRAFT BATTERY TO LOAD SOFTWARE. DO NOT USE A BATTERY CHARGER AS AN EXTERNAL POWER SOURCE DUE TO ELECTRICAL NOISE IT MAY INJECT IN THE G1000 SYSTEM.**

Power loss during a software upgrade may cause an LRU to become corrupted and unresponsive requiring replacement. Remove power only when told to do so in the procedure.

#### 3.7.2 MFD & PFD Software Load

1. Open the MFD, PFD (ESS BUS) and PFD (AVN BUS 1) circuit breakers.
2. Remove Garmin SD/MMC/FS510 cards from bottom slots of PFD and MFD if present.
3. Insert the software loader card into the MFD top card slot.
4. Turn on Avionics/electrical busses.
5. Press and hold the **ENT** key on the MFD.
6. Close the MFD circuit breaker.
7. When the “DO YOU WANT TO UPDATE SYSTEM FILES?” prompt appears, release the **ENT** key, then press the **YES** softkey.

**DO YOU WANT TO UPDATE SYSTEM FILES?  
NO WILL BE ASSUMED IN 30 SECONDS.**

8. After the new GDU software is loaded to the MFD, a “DO YOU WANT TO UPDATE THE SPLASH SCREEN?” prompt may appear. If it does, press the **NO** softkey. The splash screen will be loaded later in this procedure.

**DO YOU WANT TO UPDATE THE CUSTOM GRAPHIC FILES (EG, SPLASH SCREEN)?  
NO WILL BE ASSUMED IN 30 SECONDS.**

9. When complete, the MFD starts in configuration mode displaying the “System Status” page.
10. Open MFD circuit breaker, remove the loader card from the MFD and insert it into the PFD top card slot.
11. Repeat Steps 5 through 9 for the PFD. When complete, leave the PFD on with the loader card remaining in the top card slot.
12. Start the MFD in configuration mode by pressing and holding the **ENT** key when closing the circuit breaker. Release the key when the words “INITIALIZING SYSTEM” appear on the screen.

### 3.7.3 Baseline Software and Configuration Load

#### **IMPORTANT**

If the aircraft being modified has incorporated any modifications beyond factory configuration that effect engine or airspeed limitations, your configuration may not be supported at this time. It is the responsibility of the installer to ensure compatibility with existing modifications.

Do not allow power to be removed from the system when loading software. Remove power only when instructed by the following procedures.

Unless instructed otherwise, all displays should be in the same mode (configuration or normal).

Follow the order of software and configuration loading, do not skip or rearrange steps.

Do not operate or turn off MFD while loading software and configuration files unless specifically instructed to do so. A failed or cancelled load may result.

**If an incorrect configuration file is loaded at any time during this procedure, STOP and start the configuration load over.**

1. Ensure all avionics circuit breakers are closed and the G1000 system is fully powered.
2. On the PFD, go to the SYSTEM UPLOAD page using the small FMS knob.
3. Push in the PFD FMS knob to activate the cursor in the Group field. Rotate the small FMS knob to activate the drop-down menu. Rotate the small FMS knob to highlight the applicable airframe from the selections shown in Figure 3-8 in the drop-down menu and press the **ENT** key to select it.

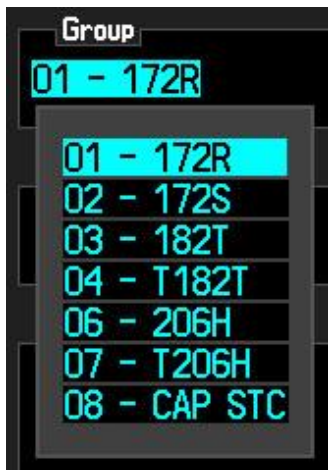

**Figure 3-8, Airframe Group Selection**

4. If an airframe type was selected that does not match the previously configured airframe type, a popup similar to the one shown in Figure 3-9 will appear. Select "NO" by pressing the "NO" softkey at the bottom of the screen. Return to the previous step and select the correct airframe type in the Airframe Group selection.

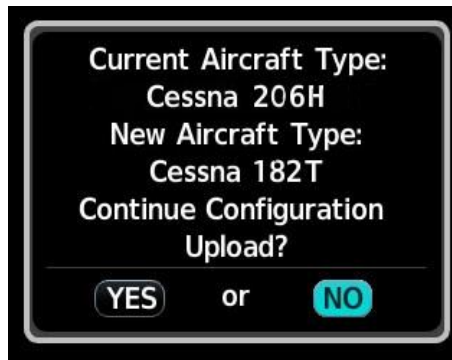

**Figure 3-9, Airframe Change Confirmation**

5. Once the appropriate airframe option is selected, the cursor moves to the ITEM window. Rotate the small FMS knob to activate the drop-down menu. Highlight “**Cessna XXX – Baseline Configuration**” (where XXX is the airframe type selected above) and press the **ENT** key to select it. The PRODUCT field will then populate.

**NOTES**

The PRODUCT window displays information regarding each G1000 LRU. The LRU column depicts the reported software version of the LRU (may be blank if PFD cannot communicate with the unit yet until after config files are loaded). The CARD VERS column shows the LRU software version stored on the Loader Card.

The SOFTWARE column may or may not have all boxes checked automatically. For the initial software load in the system all software boxes should be checked to load all files. This is done by pressing the CHK ALL softkey when instructed below.

The CONFIGURATION column defaults to having all unit configuration boxes checked.

The hardware serial number is used to determine appropriate software for the GIA COM, GIA NAV, GMU 44, and GSA 8X units. Until the system configuration loads sufficiently to access and read these units, they may show a “INV” invalid status under the LRU VERS and CARD VERS columns with up to two line items per item (representing different hardware configurations). After the configuration files are loaded, the units will update and remove the “INV” status and will load automatically.

6. Press the **CHK All** softkey.
7. Press the **Load** softkey.
8. Monitor the loading progress and verify the software load completes without errors as indicated by the following:
  - Green “PASS” or White “N/A” in all Configuration and Software columns.
  - “Upload Complete.....COMPLETE” in the summary box.
9. Press the **ENT** key to acknowledge the prompt that appears in the pop-up box.

---

### 3.7.4 GTX 335R Transponder Software/Configuration Loading (if installed)

Follow this procedure to configure the GTX 335R transponder in the aircraft. Do not follow the procedures in this section if a GTX 335R is not installed in the aircraft.

1. Move the cursor to the Item window and rotate FMS inner knob to display drop down menu. Highlight “**Baseline Option – GTX 335 Installation**” and press the **ENT** key to select it.
2. Press the **CHK All** softkey.
3. Press the **Load** softkey.
4. Monitor the loading progress and verify the software load completes without errors as indicated by the following:
  - Green “PASS” in the Configuration and Software columns for each item loaded.
  - “Upload Complete.....COMPLETE” in the summary box.
5. Press the **ENT** key to acknowledge the prompt that appears in the pop-up box.

### 3.7.5 GTX 345R without GTS 800 Transponder Software/Configuration Loading (if installed)

Follow this procedure to configure the GTX 345R transponder in the aircraft in aircraft without a GTS 800. Do not follow the procedures in this section if a GTX 345R is not installed in the aircraft or if the GTX 345R is installed with a GTS 800.

1. Move the cursor to the Item window and rotate FMS inner knob to display drop down menu. Highlight “**Baseline Option – GTX 345 Installation, without GTS 800**” and press the **ENT** key to select it.
2. Press the **CHK All** softkey.
3. Press the **Load** softkey.
4. Monitor the loading progress and verify the software load completes without errors as indicated by the following:
  - Green “PASS” in the Configuration and Software columns for each item loaded.
  - “Upload Complete.....COMPLETE” in the summary box.
5. Press the **ENT** key to acknowledge the prompt that appears in the pop-up box.

---

### 3.7.6 GTX 345R with GTS 800 Transponder Software/Configuration Loading (if installed)

Follow this procedure to configure the GTX 345R transponder in the aircraft in those aircraft that have a GTX 345R and a GTS 800 installed. Do not follow the procedures in this section if a GTX 345R is not installed in the aircraft or if there is a GTX 345R installed without a GTS 800 installed.

1. Move the cursor to the Item window and rotate FMS inner knob to display drop down menu. Highlight “**Baseline Option – GTX 345 Installation, with GTS 800**” and press the **ENT** key to select it.
2. Press the **CHK All** softkey.
3. Press the **Load** softkey.
4. Monitor the loading progress and verify the software load completes without errors as indicated by the following:
  - Green “PASS” in the Configuration and Software columns for each item loaded.
  - “Upload Complete.....COMPLETE” in the summary box.
5. Press the **ENT** key to acknowledge the prompt that appears in the pop-up box.

### 3.7.7 GDL 69A SXM Software/Configuration Loading (if installed)

Follow this procedure to configure the GDL 69A SXM Receiver. Do not follow the procedures in this section if a GDL69A SXM unit is not installed.

1. Rotate the large FMS knob until the Item field is highlighted, rotate the small FMS knob to activate the drop down menu. Rotate the small FMS knob and select “**Baseline Option – GDL 69A SXM Installation**” and press the **ENT** key to select it.
2. Press the **CHK All** softkey.
3. Press the **Load** softkey.
4. Monitor the loading progress and verify the software load completes without errors as indicated by the following:
  - Green “PASS” in the Configuration and Software columns for each item loaded.
  - “Upload Complete.....COMPLETE” in the summary box.
5. Press the **ENT** key to acknowledge the prompt that appears in the pop-up box.

---

### 3.7.8 GFC 700 Software/Configuration Loading (if installed)

Follow this procedure to configure the GFC 700 Autopilot. Do not follow the procedures in this section if the aircraft is not equipped with GFC 700.

1. Rotate the large FMS knob until the Item field is highlighted, rotate the small FMS knob to activate the drop down menu. Rotate the small FMS knob and select “**Option – GFC 700 Installation**” and press the **ENT** key to select it.
2. Press the **CHK All** softkey.
3. Press the **Load** softkey.
4. Monitor the loading progress and verify the software load completes without errors as indicated by the following:
  - Green “PASS” in the Configuration and Software columns for each item loaded.
  - “Upload Complete.....COMPLETE” in the summary box.
5. Press the **ENT** key to acknowledge the prompt that appears in the pop-up box.

### 3.7.9 Flight Stream 510 Configuration Loading (if installed)

Follow this procedure to configure the system to use the FS 510 WiFi/Bluetooth datalink. Do not follow the procedures in this section if the aircraft is not equipped with a FS 510.

1. Rotate the large FMS knob until the Item field is highlighted, rotate the small FMS knob to activate the drop down menu. Rotate the small FMS knob and select “**Option – Enable FS510**” and press the **ENT** key to select it.
2. Press the **CHK All** softkey.
3. Press the **Load** softkey.
4. Monitor the loading progress and verify the software load completes without errors as indicated by the following:
  - Green “PASS” in the Configuration column for each item loaded.
  - “Upload Complete.....COMPLETE” in the summary box.
5. Press the **ENT** key to acknowledge the prompt that appears in the pop-up box.

---

### 3.7.10 CAN Bus Fuel Level Sensors (if installed)

Follow this procedure to configure the system to use CAN Bus Fuel Level Sensors. Do not follow the procedures in this section if the aircraft is not equipped with CAN Bus Fuel Level Sensors.

1. Rotate the large FMS knob until the Item field is highlighted, rotate the small FMS knob to activate the drop down menu. Rotate the small FMS knob and select “**Option – CAN BUS FUEL LEVEL SENSORS**” and press the **ENT** key to select it.
2. Press the **CHK All** softkey.
3. Press the **Load** softkey.
4. Monitor the loading progress and verify the software load completes without errors as indicated by the following:
  - Green “PASS” in the Configuration and Software columns for each item loaded.
  - “Upload Complete.....COMPLETE” in the summary box.
5. Press the **ENT** key to acknowledge the prompt that appears in the pop-up box.

### 3.7.11 GTS 800 without GTX 345R Software/Configuration Loading (if installed)

Follow this procedure to configure the GTS 800 Traffic System. Do not follow the procedures in this section if the aircraft is not equipped with GTS 800 or if it is equipped with a GTS 800 and a GTX 345R.

#### **NOTE**

Configuration of the GTS Processor will require entering the aircraft registration number into the unit using Section 3.9, “Aircraft Registration Number Entry”.

1. Rotate the large FMS knob until the Item field is highlighted, rotate the small FMS knob to activate the drop down menu. Rotate the small FMS knob and select “**Option – GTS 800 Installation, without GTX 345**” and press the **ENT** key to select it.
2. Press the **CHK All** softkey.
3. Press the **Load** softkey.
4. Monitor the loading progress and verify the software load completes without errors as indicated by the following:
  - Green “PASS” in the Configuration and Software columns for each item loaded.
  - “Upload Complete.....COMPLETE” in the summary box.
5. Press the **ENT** key to acknowledge the prompt that appears in the pop-up box.

---

### 3.7.12 GTS 800 with GTX 345R Software/Configuration Loading (if installed)

Follow this procedure to configure the GTS 800 Traffic System. Do not follow the procedures in this section if the aircraft is not equipped with GTS 800 or if it is equipped with a GTS 800 and without a GTX 345R.

#### **NOTE**

Configuration of the GTS Processor will require entering the aircraft registration number into the unit using Section 3.9, "Aircraft Registration Number Entry".

1. Rotate the large FMS knob until the Item field is highlighted, rotate the small FMS knob to activate the drop down menu. Rotate the small FMS knob and select "**Option – GTS 800 Installation, with GTX 345**" and press the **ENT** key to select it.
2. Press the **CHK All** softkey.
3. Press the **Load** softkey.
4. Monitor the loading progress and verify the software load completes without errors as indicated by the following:
  - Green "PASS" in the Configuration and Software columns for each item loaded.
  - "Upload Complete.....COMPLETE" in the summary box.
5. Press the **ENT** key to acknowledge the prompt that appears in the pop-up box.

### 3.7.13 WX500 Configuration Loading (if installed)

Follow this procedure to configure the system to utilize the WX 500. Do not follow the procedures in this section if the aircraft is not equipped with WX500.

1. Rotate the large FMS knob until the Item field is highlighted, rotate the small FMS knob to activate the drop down menu. Rotate the small FMS knob and select "**Option – WX500 Installation**" and press the **ENT** key to select it.
2. Press the **CHK All** softkey.
3. Press the **Load** softkey.
4. Monitor the loading progress and verify the software load completes without errors as indicated by the following:
  - Green "PASS" in the Configuration and Software columns for each item loaded.
  - "Upload Complete.....COMPLETE" in the summary box.
5. Press the **ENT** key to acknowledge the prompt that appears in the pop-up box.

---

### 3.7.14 KN63 DME Configuration Loading (if installed)

Follow this procedure to configure the system to use the KN 63 DME. Do not follow the procedures in this section if the aircraft is not equipped with a KN 63.

1. Rotate the large FMS knob until the Item field is highlighted, rotate the small FMS knob to activate the drop down menu. Rotate the small FMS knob and select “**Option – KN63 DME Installation**” and press the **ENT** key to select it.
2. Press the **CHK All** softkey.
3. Press the **Load** softkey.
4. Monitor the loading progress and verify the software load completes without errors as indicated by the following:
  - Green “PASS” in the Configuration and Software columns for each item loaded.
  - “Upload Complete.....COMPLETE” in the summary box.
5. Press the **ENT** key to acknowledge the prompt that appears in the pop-up box.

### 3.7.15 KR87 ADF Configuration Loading (if installed)

Follow this procedure to configure the system to use the KR 87 ADF. Do not follow the procedures in this section if the aircraft is not equipped with a KR 87.

1. Rotate the large FMS knob until the Item field is highlighted, rotate the small FMS knob to activate the drop down menu. Rotate the small FMS knob and select “**Option – KR87 ADF Installation**” and press the **ENT** key to select it.
2. Press the **CHK All** softkey.
3. Press the **Load** softkey.
4. Monitor the loading progress and verify the software load completes without errors as indicated by the following:
  - Green “PASS” in the Configuration and Software columns for each item loaded.
  - “Upload Complete.....COMPLETE” in the summary box.
5. Press the **ENT** key to acknowledge the prompt that appears in the pop-up box.

---

### 3.7.16 GRS 77 and GDC 74 Software/Configuration Loading (if installed)

Follow this procedure to configure the system for GRS 77 and GDC 74.

1. Rotate the large FMS knob until the Item field is highlighted, rotate the small FMS knob to activate the drop down menu. Rotate the small FMS knob and select “**Baseline Option – Legacy – GRS77 and GDC74 Installation**” and press the **ENT** key to select it.
2. Press the **CHK All** softkey.
3. Press the **Load** softkey.
4. Monitor the loading progress and verify the software load completes without errors as indicated by the following:
  - Green “PASS” in the Configuration and Software columns for each item loaded.
  - “Upload Complete.....COMPLETE” in the summary box.
5. Press the **ENT** key to acknowledge the prompt that appears in the pop-up box.

### 3.7.17 GSU 75 Software/Configuration Loading (if installed)

Follow this procedure to configure the GSU 75 ADAHRS.

1. Move the cursor to the Item window and rotate FMS inner knob to display drop down menu. Highlight “**Baseline Option – GSU75 Installation**” and press the **ENT** key to select it.
2. Press the **CHK All** softkey.
3. Press the **Load** softkey.
4. Monitor the loading progress and verify the software load completes without errors as indicated by the following:
  - Green “PASS” or White “N/A” in all Configuration and Software columns.
  - “Upload Complete.....COMPLETE” in the summary box.
5. Press the **ENT** key to acknowledge the prompt that appears in the pop-up box.

### 3.7.18 GTX 33 ES Software/Configuration Loading (if installed)

Follow this procedure to configure the system to use a GTX 33 ES Transponder. Do not follow the procedures in this section if the aircraft is not equipped with a GTX 33 ES.

1. Rotate the large FMS knob until the Item field is highlighted, rotate the small FMS knob to activate the drop down menu. Rotate the small FMS knob and select “**Baseline Option – Legacy – GTX 33 ES Installation**” and press the **ENT** key to select it.
2. Press the **CHK All** softkey.
3. Press the **Load** softkey.
4. Monitor the loading progress and verify the software load completes without errors as indicated by the following:
  - Green “PASS” in the Configuration and Software columns for each item loaded.
  - “Upload Complete.....COMPLETE” in the summary box.
5. Press the **ENT** key to acknowledge the prompt that appears in the pop-up box.

---

### 3.7.19 GDL 69 Software/Configuration Loading (if installed)

Follow this procedure to configure the GDL 69 Receiver. Do not follow the procedures in this section if a GDL69 unit is not installed or if a GDL 69A SXM unit is installed.

1. Rotate the large FMS knob until the Item field is highlighted, rotate the small FMS knob to activate the drop down menu. Rotate the small FMS knob and select “**Baseline Option – Legacy – GDL 69 Installation**” and press the **ENT** key to select it.
2. Press the **CHK All** softkey.
3. Press the **Load** softkey.
4. Monitor the loading progress and verify the software load completes without errors as indicated by the following:
  - Green “PASS” in the Configuration and Software columns for each item loaded.
  - “Upload Complete.....COMPLETE” in the summary box.
5. Press the **ENT** key to acknowledge the prompt that appears in the pop-up box.

### 3.7.20 Disable CO Guardian Configuration Loading (if CO Guardian not installed)

Follow this procedure to disable the CO Guardian (if a CO Guardian is not installed). Do not follow the procedures in this section if the aircraft is equipped with a CO Guardian.

1. Rotate the large FMS knob until the Item field is highlighted, rotate the small FMS knob to activate the drop down menu. Rotate the small FMS knob and select “**Option – Disable CO Guardian Installation**” and press the **ENT** key to select it.
2. Press the **CHK All** softkey.
3. Press the **Load** softkey.
4. Monitor the loading progress and verify the software load completes without errors as indicated by the following:
  - Green “PASS” in the Configuration and Software columns for each item loaded.
  - “Upload Complete.....COMPLETE” in the summary box.
5. Press the **ENT** key to acknowledge the prompt that appears in the pop-up box.

---

### 3.7.21 KTA 870 Configuration Loading (if installed)

Follow this procedure to configure the system to use a KTA 870 Traffic System without the GTX 345R transponder. Do not follow the procedures in this section if the aircraft is not equipped with a KTA 870.

1. Rotate the large FMS knob until the Item field is highlighted, rotate the small FMS knob to activate the drop down menu. Rotate the small FMS knob and select “**Option – KTA870 TAS Installation**” and press the **ENT** key to select it.
2. Press the **CHK All** softkey.
3. Press the **Load** softkey.
4. Monitor the loading progress and verify the software load completes without errors as indicated by the following:
  - Green “PASS” in the Configuration and Software columns for each item loaded.
  - “Upload Complete.....COMPLETE” in the summary box.
5. Press the **ENT** key to acknowledge the prompt that appears in the pop-up box.

### 3.7.22 KAP 140 Configuration Loading (if installed)

Follow this procedure to configure the system to use a KAP 140 Autopilot. Do not follow the procedures in this section if the aircraft is not equipped with a KAP 140.

1. Rotate the large FMS knob until the Item field is highlighted, rotate the small FMS knob to activate the drop down menu. Rotate the small FMS knob and select “**Option – KAP 140 Installation**” and press the **ENT** key to select it.
2. Press the **CHK All** softkey.
3. Press the **Load** softkey.
4. Monitor the loading progress and verify the software load completes without errors as indicated by the following:
  - Green “PASS” in the Configuration and Software columns for each item loaded.
  - “Upload Complete.....COMPLETE” in the summary box.
5. Press the **ENT** key to acknowledge the prompt that appears in the pop-up box.

---

### 3.7.23 Pre BP 2007 CI 2480-400 Antenna Configuration Loading (if installed)

Follow this procedure to configure the system to use a CI 2480-400 Antenna (Pre BP 2007 aircraft). Do not follow the procedures in this section if the aircraft is not a Pre-BP 2007 Aircraft with CI 2480-400 Antenna installed.

1. Rotate the large FMS knob until the Item field is highlighted, rotate the small FMS knob to activate the drop down menu. Rotate the small FMS knob and select “**Option – Pre BP 2007 Comant CI 2480-400 Antenna Configuration**” and press the **ENT** key to select it.
2. Press the **CHK All** softkey.
3. Press the **Load** softkey.
4. Monitor the loading progress and verify the software load completes without errors as indicated by the following:
  - Green “PASS” in the Configuration and Software columns for each item loaded.
  - “Upload Complete.....COMPLETE” in the summary box.
5. Press the **ENT** key to acknowledge the prompt that appears in the pop-up box.

### 3.7.24 BP 2007 CI 2580-410 Antenna Configuration Loading (if installed)

Follow this procedure to configure the system to use a CI 2580-410 Antenna (BP 2007 aircraft). Do not follow the procedures in this section if the aircraft is not a BP 2007 Aircraft with CI 2580-410 Antenna installed.

1. Rotate the large FMS knob until the Item field is highlighted, rotate the small FMS knob to activate the drop down menu. Rotate the small FMS knob and select “**Option – BP 2007 Comant CI 2580-410 Antenna Configuration**” and press the **ENT** key to select it.
2. Press the **CHK All** softkey.
3. Press the **Load** softkey.
4. Monitor the loading progress and verify the software load completes without errors as indicated by the following:
  - Green “PASS” in the Configuration and Software columns for each item loaded.
  - “Upload Complete.....COMPLETE” in the summary box.
5. Press the **ENT** key to acknowledge the prompt that appears in the pop-up box.

---

### 3.7.25 Initialize Fuel Cal Data (Only for CAN Bus Fuel sensors before fuel cal)

Follow this procedure to initialize fuel cal data. This section is only for aircraft with CAN Bus Fuel Sensor and only before the fuel calibration is completed.

1. Rotate the large FMS knob until the Item field is highlighted, rotate the small FMS knob to activate the drop down menu. Rotate the small FMS knob and select “**Option – INITIALIZE FUEL CAL DATA (only for CAN Bus sensors before fuel cal)**” and press the **ENT** key to select it.
2. Press the **CHK All** softkey.
3. Press the **Load** softkey.
4. Monitor the loading progress and verify the software load completes without errors as indicated by the following:
  - Green “PASS” in the Configuration and Software columns for each item loaded.
  - “Upload Complete.....COMPLETE” in the summary box.
5. Press the **ENT** key to acknowledge the prompt that appears in the pop-up box.

### 3.7.26 Delete CAN Fuel Sensor Fuel Calibration (if installed)

Follow this procedure to delete the CAN Bus Fuel Sensor Fuel Calibration.

1. Rotate the large FMS knob until the Item field is highlighted, rotate the small FMS knob to activate the drop down menu. Rotate the small FMS knob and select “**Option – Delete CAN Fuel Sensor Fuel Calibration**” and press the **ENT** key to select it.
2. Press the **CHK All** softkey.
3. Press the **Load** softkey.
4. Monitor the loading progress and verify the software load completes without errors as indicated by the following:
  - Green “PASS” in the Configuration and Software columns for each item loaded.
  - “Upload Complete.....COMPLETE” in the summary box.
5. Press the **ENT** key to acknowledge the prompt that appears in the pop-up box.

---

### 3.7.27 KTA 870 TAS with GTX 345R Transponder Software/Configuration Loading (if installed)

Follow this procedure to configure the GTX 345R transponder in the aircraft in those aircraft that have a GTX 345R and a KTA 870 installed. Do not follow the procedures in this section if a GTX 345R is not installed in the aircraft or if there is a GTX 345R installed without a KTA 870 installed.

1. Move the cursor to the Item window and rotate FMS inner knob to display drop down menu. Highlight “**Baseline Option –KTA 870 TAS Installation, with GTX345R**” and press the **ENT** key to select it.
2. Press the **CHK All** softkey.
3. Press the **Load** softkey.
4. Monitor the loading progress and verify the software load completes without errors as indicated by the following:
  - Green “PASS” in the Configuration and Software columns for each item loaded.
  - “Upload Complete.....COMPLETE” in the summary box.
5. Press the **ENT** key to acknowledge the prompt that appears in the pop-up box.

### 3.7.28 Save Configuration

1. Press the **UPDT CFG** softkey at the bottom of the SYSTEM UPLOAD page.
2. Press the **ENT** key to select YES in the pop-up window to start the update.
3. When the config module update is done, press the **ENT** key to select OK in the pop-up window to close it.
4. Open PFD circuit breakers, remove the software loader card.

---

### 3.8 Feature Enablement

This section describes how to unlock or enable optional features. The installer will only load the sections for the features they require. For installing all feature enablement cards, the PFD and the MFD must be in configuration mode.

The G1000 has various features that require the use of unlock/enable cards to activate the feature. Throughout this document these cards are generically referred to as 'enablement cards'. In some cases, the actual label on the physical card may say 'unlock'.

**If uncertain what SD Card to use, the technician must verify the card part number on the General Arrangement drawing prior to use to assure the correct feature is unlocked.**

#### 3.8.1 ChartView Feature Enablement

Follow this procedure to activate Jeppesen ChartView. Enabling this feature, allows the pilot to switch between Garmin FliteCharts and Jeppesen ChartView products.

#### NOTES

The required ChartView databases are subscription-based and need to be procured by the installing agency from the Garmin or Jeppesen website. The ChartView database is not present in a new display.

1. Insert the ChartView Enablement card in the top slot of the PFD and power on the PFD in configuration mode.
2. If a message appears on the PFD stating an "arfrm\_imgs.zip" file is not present, follow the on screen instructions to continue. This file will be loaded in Section 3.11
3. On the PFD, select the "**System Upload**" page using the small FMS knob.
4. Push in the FMS knob to activate the cursor in the Group field. Rotate the small FMS knob to highlight "**Configuration Files**" and press the **ENT** key to select it.
5. In the ITEM window, rotate the small FMS knob to highlight "**Enable ChartView**" and press the **ENT** key to select it.
6. Press the **Load** softkey.
7. Monitor load progress. Verify software load completes without errors as indicated by the following:
  - Green "PASS" in the Configuration column for each item loaded.
  - "Upload Complete.....COMPLETE" in the summary box.
8. Press the **ENT** key to acknowledge the prompt that appears in the pop-up box.
9. Open the PFD circuit breakers and remove the ChartView enablement card.

---

### 3.8.2 Synthetic Vision System Enablement

Follow this procedure to enable the Synthetic Vision feature.

1. Insert the SVS Enablement card in the top slot of the PFD and power on the PFD in configuration mode.
2. If a message appears on the PFD stating an “arfrm\_imgs.zip” file is not present, follow the on screen instructions to continue. This file will be loaded in Section 3.11.
3. On the PFD, select the “**System Upload**” page using the small FMS knob.
4. Push in the FMS knob to activate the cursor in the Group field. Rotate the small FMS knob to highlight “**Configuration Files**” and press the **ENT** key to select it.
5. In the ITEM window, rotate the small FMS knob to highlight “**Enable SVS Single PFD**” and press the **ENT** key to select it.
6. Press the **Load** softkey.
7. Monitor load progress. Verify software load completes without errors as indicated by the following:
  - Green “PASS” in the Configuration column for each item loaded.
  - “Upload Complete.....COMPLETE” in the summary box.
8. Press the **ENT** key to acknowledge the prompt that appears in the pop-up box.
9. Open the PFD circuit breakers and remove SVS enablement card.

### 3.8.3 SurfaceWatch Enablement

Follow this procedure to enable the SurfaceWatch feature.

1. Insert the SurfaceWatch Enablement card in the top slot of the PFD and power on the PFD in configuration mode.
2. If a message appears on the PFD stating an “arfrm\_imgs.zip” file is not present, follow the on screen instructions to continue. This file will be loaded in Section 3.11.
3. On PFD, select the “**System Upload**” page using the small FMS knob.
4. Push in the FMS knob to activate the cursor in the Group field. Rotate the small FMS knob to highlight “**Enable\_SurfaceWatch**” and press the **ENT** key to select it.
5. In the ITEM window, rotate the small FMS knob to highlight “**SurfaceWatch Feature Enable**” and press the **ENT** key to select it.
6. Press the **Load** softkey.
7. Monitor load progress. Verify software load completes without errors as indicated by the following:
  - Green “PASS” in the Configuration column for each item loaded.
  - “Upload Complete.....COMPLETE” in the summary box.
8. Press the **ENT** key to acknowledge the prompt that appears in the pop-up box.
9. Open PFD circuit breaker and remove the SurfaceWatch enablement card.

---

### 3.8.4 TAWS-B Enablement

Follow this procedure to enable the TAWS-B feature.

1. Insert the TAWS-B Enablement card in the top slot of the PFD, power on the PFD in configuration mode.
2. If a message appears on the PFD stating an “arfrm\_imgs.zip” file is not present, follow the on screen instructions to continue. This file will be loaded in Section 3.11.
3. On the PFD, select the “**System Upload**” page using the small FMS knob.
4. Push in the FMS knob to activate the cursor in the Group field. Rotate the small FMS knob to highlight “**Configuration Files**” and press the **ENT** key to select it.
5. In the ITEM window, rotate the small FMS knob to highlight “**Enable TAWS**” and press the **ENT** key to select it.
6. Press the **Load** softkey.
7. Monitor load progress. Verify software load completes without errors as indicated by the following:
  - Green “PASS” in the Configuration column for each item loaded.
  - “Upload Complete.....COMPLETE” in the summary box.
8. Press the **ENT** key to acknowledge the prompt that appears in the pop-up box.
9. Open the PFD circuit breaker and remove TAWS-B enablement card.

### 3.8.5 Enhanced Search and Rescue Enablement

Follow this procedure to enable the Enhanced Search and Rescue (SAR) feature.

1. Insert the Enhanced SAR Enablement card in the top slot of the PFD, power on PFD in configuration mode.
2. If a message appears on the PFD stating an “arfrm\_imgs.zip” file is not present, follow the on screen instructions to continue. This file will be loaded in Section 3.11.
3. On the PFD, select the “**System Upload**” page using the small FMS knob.
4. Push in the FMS knob to activate the cursor in the Group field. Rotate the small FMS knob to highlight “**Enhanced SAR**” and press the **ENT** key to select it.
5. In the ITEM window, rotate the small FMS knob to highlight “**Enhanced Search and Rescue**” and press the **ENT** key to select it.
6. Press the **Load** softkey.
7. Monitor load progress. Verify software load completes without errors as indicated by the following:
  - Green “PASS” in the Configuration column for each item loaded.
  - “Upload Complete.....COMPLETE” in the summary box.
8. Press the **ENT** key to acknowledge the prompt that appears in the pop-up box.
9. Open the PFD circuit breaker and remove Enhanced SAR enablement card.

---

### 3.8.6 Search and Rescue Enablement (not required if enhanced SAR is enabled)

Follow this procedure to enable the Search and Rescue (SAR) feature.

1. Insert the SAR Enablement card in the top slot of the PFD, power on PFD in configuration mode.
2. If a message appears on the PFD stating an “arfrm\_imgs.zip” file is not present, follow the on screen instructions to continue. This file will be loaded in Section 3.11.
3. On the PFD, select the “**System Upload**” page using the small FMS knob.
4. Push in the FMS knob to activate the cursor in the Group field. Rotate the small FMS knob to highlight “**Configuration Files**” and press the **ENT** key to select it.
5. In the ITEM window, rotate the small FMS knob to highlight “**Enable SAR**” and press the **ENT** key to select it.
6. Press the **Load** softkey.
7. Monitor load progress. Verify software load completes without errors as indicated by the following:
  - Green “PASS” in the Configuration column for each item loaded.
  - “Upload Complete.....COMPLETE” in the summary box.
8. Press the **ENT** key to acknowledge the prompt that appears in the pop-up box.
9. Open the PFD circuit breaker and remove the SAR enablement card.

---

### 3.9 Aircraft Registration Number Entry and Flight ID Configuration

#### 3.9.1 Aircraft Equipped with GTX 335R or GTX 345R

##### Aircraft Registration Number Entry

1. Insert the software loader card into the top slot of the PFD.
2. Place the PFD in configuration mode.
3. Press the **NO** softkey (number 11 softkey) to acknowledge the following prompt.

**DO YOU WANT TO UPDATE SYSTEM FILES?  
NO WILL BE ASSUMED IN 30 SECONDS.**

4. Rotate the small FMS knob, select the **AIRCRAFT CONFIGURATION** page on PFD.
5. Activate the cursor to select the **“AIRCRAFT REGISTRATION”** field and enter the aircraft’s tail number.
6. If the ICAO Address field does not auto-fill, rotate the large FMS knob to select the **“ICAO ADDRESS”** and enter the aircraft’s 24 bit ICAO address.
7. If applicable, rotate the large FMS knob to select the **“ICAO REGION”** field and select the appropriate ICAO region.
8. If applicable, rotate the large FMS knob to select the **“DOMAIN IDENTIFIER”** field and enter the number. Press the ENT key to save. Otherwise, leave blank
9. Rotate the large FMS knob to select the **“VFR CODE”** field and enter the desired code that will become active when the VFR key on the GDU is pressed.
10. Press the **SET GTS** softkey (if present) and acknowledge the prompt by pressing the **ENT** key.
11. Deactivate the cursor.
12. Rotate large FMS knob to select **“GTX 3X5.”**
13. Rotate the small FMS knob to select **“Transponder Airframe Configuration”** page.
14. Verify the GTX1 box at the top of the page is green and the tail number, ICAO address, IATA Airline Designator, and VFR code that were entered previously are correct.

##### Flight ID Configuration

1. Select the **GTX 3X5** Group and the **Transponder Airframe Config** page on the PFD.
2. Activate the cursor and select the **“Allow Flight ID Entry”** field.
3. Rotate the small FMS knob to activate the drop-down menu.
4. Select **“PFD ENTRY”** and press the **ENT** key.
5. Scroll Down to highlight **“SET > ACTIVE”** and press the **ENT** key.
6. After completing transponder configuration, deactivate the cursor.

---

### 3.10 Configuration Manager

#### **NOTE**

All items listed in the Configuration Manager will display “Valid” in the Status column.

1. Rotate the large FMS knob to select “**SYSTEM**”.
2. Rotate the small FMS knob to select Configuration Manager page on PFD.
3. Press the softkey labelled CNFM CFG on PFD.
4. Press the **ENT** key on PFD to select OK when prompted to confirm configuration as expected configuration.
5. Verify the fleet, aircraft expected and actual configuration IDs match.
6. If they do not match, repeat steps 2-4. If they match, continue to next step.
7. Open MFD, PFD (ESS BUS), and PFD (AVN BUS 1) circuit breakers.

### 3.11 Splash Screen Loading

When all software and configuration has been loaded, the splash screens must be loaded to the display units (PFD and MFD).

1. Insert the software loader card in the upper slot of the MFD.
2. Close MFD circuit breaker.
3. When prompted to update system files, press the **NO** softkey.
4. When prompted to update splash screen files, press the **YES** softkey.
5. When the SYSTEM STATUS configuration page appears, Open the MFD circuit breaker.
6. Remove the loader card from the MFD and insert it into the upper slot of the PFD.
7. Close PFD (ESS BUS) circuit breaker.
8. When prompted to update system files, press the **NO** softkey.
9. When prompted to update splash screen files, press the **YES** softkey.

When the SYSTEM STATUS configuration page appears, Open PFD (ESS BUS) circuit breaker.

---

### 3.12 Database Loading

Follow this procedure to load the databases.

1. Obtain the following databases from fly.garmin.com and install on a blank 16GB or larger card or by obtaining Garmin SD Card p/n 010-00474-50. Databases with an asterisk are not included on the p/n 010-00474-50 SD card. When obtaining the databases from fly.garmin.com and using SD cards smaller than 16GB, you may need to use multiple cards (or reuse one) to load all the databases into the G1000 system.
  - a. Terrain (Worldwide, 4.9 Arc Second, TBD2 format)
  - b. Obstacle (US/Canada/Europe, OBD2 format)
  - c. AOPA Airport Directory (US)
  - d. AC-U-KWIK Airport Directory\*
  - e. SafeTaxi (US, North America\*, Canada\*, Europe\*, Full Coverage\*)
  - f. Basemap (Worldwide)
  - g. Garmin FliteCharts (US, Canada\*, Europe\*)
  - h. Jeppesen ChartView\*
  - i. IFR/VFR Charts (US)
  - j. Navigation\*
2. With the displays off, insert the SD card into the MFD bottom slot.
3. Apply power to the PFD and the MFD.
4. On the MFD, database verification messages may appear. If so, follow the on-screen instructions to continue.
5. Go to the MFD Aux - Databases page to monitor the automatic database update progress. The new databases will show "Syncing" to the Standby column. After the databases are synchronized, the system will verify them for use by showing "Verifying" in the Standby column. After the databases are verified, a cyan double arrow symbol will appear between the Standby and Active columns to show which databases will be transferred to Active use on the next power cycle or restart.

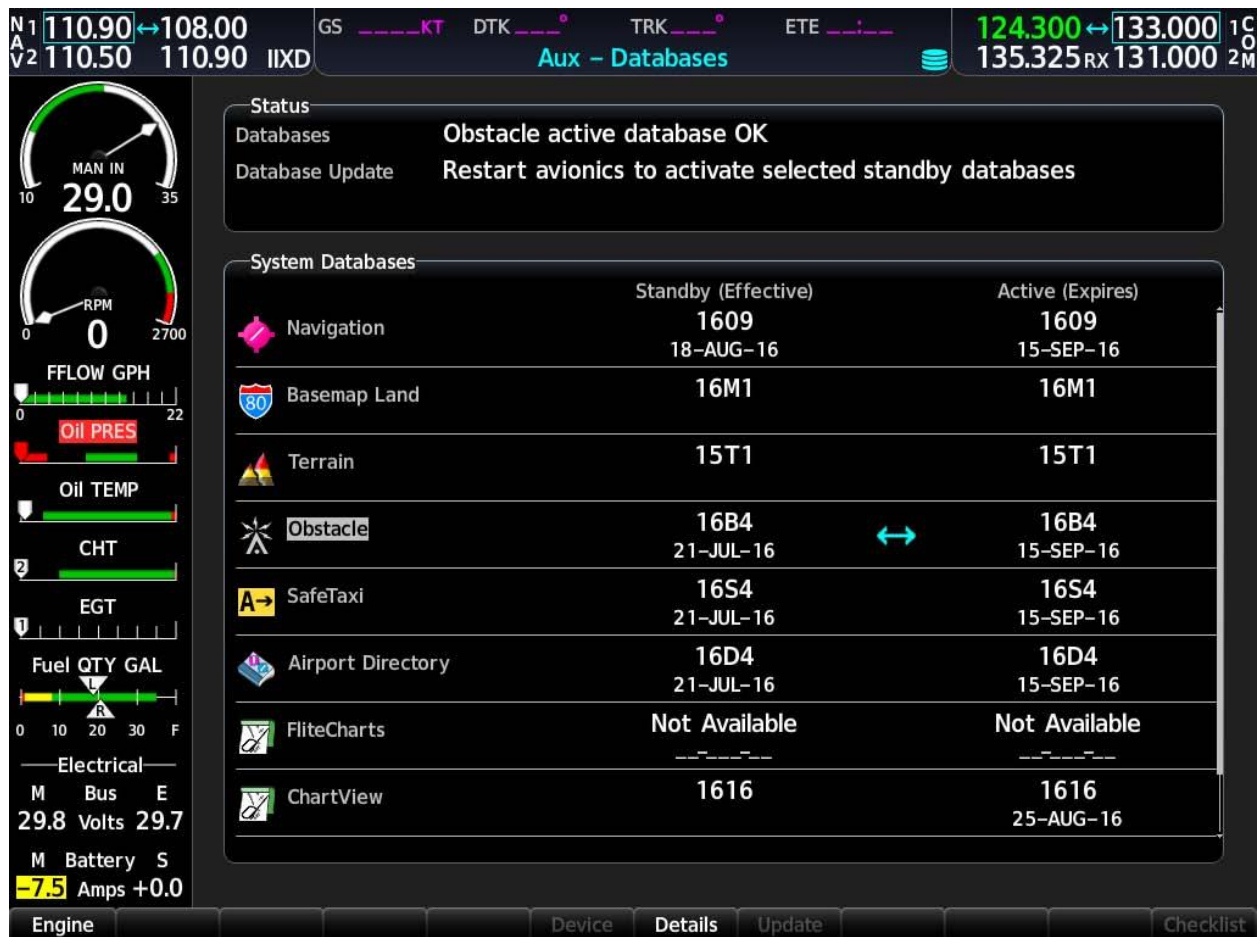

**Figure 3-10, MFD Aux - Database Page DB Transfer**

6. When all database updates are complete, the Database Update field at the top of the screen will say, "Restart avionics to activate selected standby databases." If the engine is not running, a **Restart** softkey appears at the bottom of the MFD. Press **Restart** to cycle power on the displays. If the Restart softkey is not present, turn **OFF** PFD and MFD.
7. Remove the database update card from the top slot of the MFD.
8. Turn **ON** the displays.
9. The displays may state they are verifying databases at power-up. If so, follow the on-screen instructions to continue.
10. Go to the MFD Aux - Databases page and verify the uploaded databases transferred from the Standby column to the Active column. If any did not transfer, follow these steps to initiate a manual transfer -
  - a. Push the FMS knob on the MFD controller to turn on the cursor.
  - b. Turn the FMS knob to highlight the database to transfer to the Active column.
  - c. Press the **ENT** key on the MFD and a cyan double arrow will appear between the Standby and Active columns.
  - d. Restart the displays.
  - e. Go to the MFD Aux - Databases page and confirm the databases transferred.

---

### 3.13 Clearing Default User Settings

1. Open MFD, PFD (ESS BUS), and PFD (AVN BUS 1) circuit breakers.
2. While holding the **CLR** button on the PFD, close the PFD (ESS BUS) circuit breaker.
3. When prompted to clear user settings, select the **YES** softkey.
4. When user settings have been cleared appears on the screen, Open the PFD (ESS BUS) circuit breaker.
5. Wait ten seconds, then while holding the **CLR** button on the MFD, close the MFD circuit breaker.
6. When prompted to clear user settings, select the **YES** softkey.
7. When user settings have been cleared appears on the screen, open MFD circuit breaker.

### 3.14 Interface Confirmation

#### 3.14.1 Lightning Detection System Configuration Load Confirmation

Coordinate the StormScope configuration with Section 3.7.13.

1. With PFD in configuration mode, use the PFD large FMS knob to select OTHER and the Stormscope configuration page.



Figure 3-11, Stormscope Configuration Page

2. Activate the cursor to highlight the DATA field. Use the small FMS knob to open the drop down menu then select 'Config' and press ENT key on the PFD.

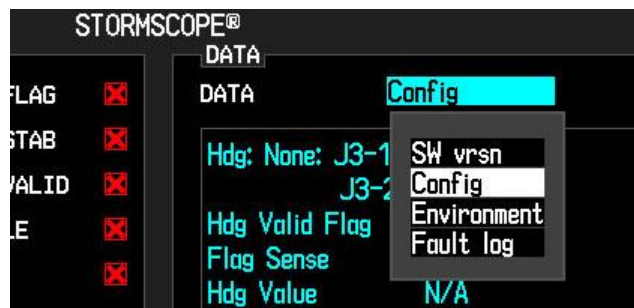

Figure 3-12, Stormscope Configuration

3. Verify that the DATA window shows the following:

Hdg: None:	J3-1	Open
	J3-2	Open
Hdg Valid Flag		N/A
Flag Sense		N/A
	J3-4	Open
Hdg Value	N/A	
Inhibit Line	Off	
Antenna Mount	Bottom	
	J3-3	Open

4. Deactivate the cursor.

**NOTE**

The DATA window is only updated once every five seconds.

**3.15 Flight Stream 510 Firmware Review**

If the optional Flight Stream 510 is installed, technician must review the reported Flight Stream firmware version and compare it to the version approved by the STC.

Reference the STC General Arrangement drawing to find the approved firmware release (see Table 1-2).

**NOTE**

This STC approves a major release of Flight Stream 510 and allows for periodic minor software updates to account for low-level driver and Bluetooth interface updates. Example – If the STC data specifies version 2.62 or higher to version 2.69 as the approved version.

At the time of installation, minor firmware updates may be available. Technician may check for updates to the firmware by following this procedure.

**CAUTION**

The technician must review the Flight Stream 510 version approved by this STC and ensure a newer major release is not utilized. Otherwise, incompatibility with the GDU display software may result.

---

## **NOTE**

Note that Flight Stream firmware update requires a device running iOS 8.1 or later -

- iPhone 5 and newer
- iPad 3 and newer
- iPad Air and newer
- iPad Mini with Retina and newer

It also requires that the above device to run Garmin Pilot App v7.1 or higher.

Firmware update is not supported via Android devices at the time of writing this document.

1. Download Garmin Pilot on the iOS device
2. Create an account in the Garmin Pilot App. If an account exists already, log in to the account.
3. Contact Garmin Aviation Product Support - <https://fly.garmin.com/fly-garmin/support/> - identify yourself as a Garmin Dealer, and request access to update Flight Stream Firmware.
4. After Support grants access, refresh Subscription page in Garmin Pilot (swipe down across page to refresh)
5. Garmin Pilot will show a "Dealer Mode" subscription.

---

#### 4. Instructions for Continued Airworthiness

##### 4.1 Airworthiness Limitations

The G1000 Integrated Flight Deck including the GFC 700 AFCS is airworthy when installed, configured, and maintained in accordance with this section.

There are no new (or additional) airworthiness limitations associated with this equipment and/or installation (STC SA01945WI). This type design change does not remove or affect any existing airworthiness limitations as defined in the aircraft maintenance manual.

The Garmin G1000 Textron Nav III Series Airplane Flight Manual Supplement defines all operating limitations for this STC.

The Airworthiness Limitations section is FAA-approved and specifies maintenance required under §§ 43.16 and 91.403 of Title 14 of the Code of Federal Regulations unless an alternative program has been FAA-approved.

FAA APPROVED

  
\_\_\_\_\_  
Paul Mast  
STC Unit Administrator  
ODA-240087-CE

  
\_\_\_\_\_

Date

---

## 4.2 Servicing Information

G1000 LRU maintenance is 'on condition' only. No component-level overhaul is required for this type design change.

### 4.2.1 On Condition Servicing

'On Condition' replacement and/or servicing should occur when an item exhibits conditions, symptoms, and/or abnormalities defined in Section 5 of this manual. Replacement and/or servicing should be made only after the technician troubleshoots the system to the extent determined necessary by using the guidance in this manual along with common avionics maintenance practices.

#### **IMPORTANT!**

**It is impossible to provide guidance for every conceivable failure scenario within the scope of this manual. Every effort has been made to provide comprehensive guidance for possible failures. The information in this document should always be combined with sound aviation maintenance practices and a thorough knowledge of the system. Use sound avionics maintenance practices when working around or on G1000 equipment.**

The remainder of this document is organized in the following fashion:

- Section 4.3 lists maintenance requirements related to the G1000 system.
- Section 6 gives instructions regarding the removal and replacement of physical G1000 equipment and parts.
- Section 7 gives configuration and testing instructions to be accomplished if G1000 equipment or parts are removed or replaced.
- Section 9 specifies system return-to-service procedures.

The beginning of Section 6 provides instructions to check the software part number and version of each LRU before removing a unit. Procedures in Section 7 require the same check after LRU replacement and software loading.

#### **IMPORTANT!**

**All structural repairs associated with this installation are to be addressed in accordance with the Cessna Structural Repair Manual listed in Table 1-1.**

---

#### 4.2.2 Required Tools

The following tools are needed to perform maintenance tasks on G1000 equipment:

- Calibrated Milliohm meter, OR
  - Agilent 34410A Ammeter or equivalent
  - Fluke 187 Voltmeter or equivalent
  - Variable DC Power Supply capable of providing 1 amp current
- #2 Non-Magnetic Phillips Screwdriver
- 3/32" Hex tool
- Calibrated VHF NAV/COM/ILS ramp tester or equivalent
- Calibrated transponder ramp tester or equivalent
- Calibrated pitot/static ramp tester
- Outdoor line-of-site to GPS satellite signals or GPS indoor repeater
- Headset/microphone
- Ground Power Unit (Capable of supplying 28 VDC)

### 4.3 Maintenance Intervals

Table 4-1 shows systems and items, installed by this STC, which must undergo tests or checks at specific intervals. If the interval is shown in flight time as well as calendar months, the first interval reached should be used as the limit.

#### **IMPORTANT!**

**The tolerance for inspection times is the same as that stated in 5-10-00 of the Cessna Maintenance Manual applicable to the airframe.**

The intention of Garmin is to align this maintenance program as best as possible with the existing Cessna Nav III inspection program. For a complete description of the Cessna inspection program, refer to the Cessna Maintenance Manuals listed in Table 1-1.

For equipment not listed here, refer to the G1000 Nav III Line Maintenance Manual.

**Table 4-1, Maintenance Intervals**

Item	Description/Procedure	Manual Section No.	Interval
<b>G1000/GFC 700 Equipment</b>			
GDU 1054B PFD and MFD (Qty 2) or GDU 1050 PFD and MFD (Qty 2)	Removal & Replacement	6.1	On Condition
GTX 335R or GTX 345R Transponder	Removal & Replacement	6.2	On Condition
	Special Inspection - Perform GTX 335R, GTX 345R test.	7.2.3	24 Calendar Months
GDL 69A SXM	Removal & Replacement	6.3	On Condition
GSU 75 ADAHRS	Removal & Replacement	6.4	On Condition
	Magnetic variation database update.	4.5	On Condition
	Special Inspection – Perform Air Data Test.	7.4.4	24 Calendar Months
G1000 Redundant Connection Check	Verify PRI and SEC power sources for PFD, GIA 1, GDC and GRS. Verify secondary paths for GDC, GRS, GDC engine parameters and GPS data. Verify the operation of PFD and MFD Ethernet connections. Verify ARINC connection between GRS, GDC, and MFD. Verify DISPLAY BACKUP button function.	4.6	24 Calendar Months
<b>G1000 Accessories</b>			
Configuration Module Replacement	Removal & Replacement.	6.5	On Condition
<b>G1000 Lightning Protection</b>			
Electrical Bonding Test	Perform the electrical bonding resistance check of G1000 equipment.	4.4.3	24 Calendar Months

---

## 4.4 Electrical Bonding Test

The following bonding tests are provided for G1000-equipped Nav III Series aircraft as a requirement beyond what is given in the 172, 182, or 206 Series Maintenance Manual.

### 4.4.1 Requirements

All G1000 equipment must be installed. Gain access for the procedure listed below in Section 4.4.3 as required and in accordance with the Cessna Nav III Series Maintenance Manuals.

### 4.4.2 Test Equipment

A milliohm meter and Kelvin probes are recommended for this test. However, an alternate method may be used to provide equivalent results by using the following procedure and a standard voltmeter, power supply with adjustable current limit, and ammeter. The test set up for this alternate method is described below.

All test equipment used for the bond checks must be calibrated.

1. Connect the positive lead of the power supply to airframe ground. Connect/touch the positive lead of the voltmeter to the same point.

#### **NOTE**

Ensure that the voltmeter and power supply probes do not touch, so as not to induce contact resistance.

2. Touch negative lead of power supply to each of the test points listed while performing Step 3. At each required point, configure the power supply to produce 1 amp before measuring voltage. (Use an ammeter to ensure current is within *minimum* of 1 amp  $\pm 100$  milliamp at each point). Do not allow the reference current to exceed 1.5 amps for safety.
3. With the current set to 1A, the voltage reading will be the value of the bonding resistance. Set the voltmeter to measure millivolts and null the reading. Measure the voltage from airframe ground (step 1) to each required test points and record the voltage. (Perform Step 2 at each required point and ensure that *minimum* of 1 amp  $\pm 100$  milliamp is present when measuring the voltage.)

TIP: When a 1A current is used all the millivolt readings are the same as milliohms, and required no further calculation of bond resistance. If 1 amp reference current cannot be maintained and is higher divide the measured voltage by current to get the resistance value. Alternatively, calculate the percentage increase in current and then reduce the measured voltage reading by the same percentage. Example: If the measured current is 1.2 amps, (20% high from the desired 1 amp current) and the measured voltage is 3.0 millivolts, then the value recorded will be 3 millivolts reduced by 20% which is 2.4 millivolts which is the same as 2.4 milliohms.

---

#### 4.4.3 Electrical Bonding Procedure

Using one of the two measurement methods in Section 4.4.2 record the bonding measurement for the following equipment. Some equipment in the list is optional and may not be installed.

Ensure that the PFD unit, and MFD unit test points, no more than 40 mΩ is present. Ensure that at other unit test points, no more than 5 mΩ is present.

##### Pilot Compartment

- Metal case of PFD: \_\_\_\_\_ mΩ
- Metal case of MFD: \_\_\_\_\_ mΩ
- GDL 69A body (182 and 206 only): \_\_\_\_\_ mΩ

##### Rear Fuselage and Empennage

- GDL 69A body (172 only): \_\_\_\_\_ mΩ
- GSU 75 body: \_\_\_\_\_ mΩ
- GTX 335R or GTX 345R body: \_\_\_\_\_ mΩ

#### 4.5 GSU 75 Earth Magnetic Field Updates

The GSU 75, utilizes an Earth magnetic field model which is updated once every five years. The update is expected to be available from Garmin every five years, as long as the GSU 75, remain Garmin-supported products.

The G1000 system alerts the operator that the magnetic field database is out of date by issuing the message “AHRS SERVICE – AHRS Magnetic-field model needs update”. Garmin will distribute updates as part of the navigation database cycle. If the IGRF model in the update is newer than the model installed, a prompt will appear for each GRS/GSU (Select “OK” to update the IGRF Magnetic Field Model). Use the FM Knob and ENT key to select “OK”.

#### 4.6 G1000 Redundant Connection Check

Perform the following steps to verify the following:

- (A) The primary (PRI) and secondary (SEC) power sources for the PFD, GDC and GRS.
- (B) The GRS 77 and GDC 74A data path to PFD and MFD.

##### **(A) PRI and SEC power sources for PFD, GRS and GDC check**

1. Connect a ground power unit to the external power receptacle and turn on the ground power unit.
2. Set the BAT and AVIONICS MASTER PWR switches to ON.
3. With the G1000 system in normal mode, pull the following circuit breakers on the circuit breaker panel:
  - PFD (ESS BUS)
  - ADC/AHRS (ESS BUS)
  - NAV 1/ENG (ESS BUS)

- 
4. Wait at least 5 seconds, then verify the data on the PFD remains valid and the following alert messages are not present:
    - GIA 1 FAIL (or any related message such as COM1, NAV1, XPDR1, GPS1)
    - AHRS 1 FAIL
    - ADC 1 FAIL
  5. Close the circuit breakers listed in step 3.
  6. Repeat step 4.
  7. Pull the following circuit breakers on the circuit breaker panel:
    - PFD (AVN BUS 1)
    - ADC/AHRS (AVN BUS 1)
    - NAV 1/ENG (AVN BUS 1)
  8. Wait at least 5 seconds, then repeat step 4.
  9. Close the circuit breakers listed in step 7.

Note: Section B is not required if a GSU 75 is not installed. Refer to the Cessna Nav III Line Maintenance Manual for procedures if a GDC 74A and GRS 77 are installed.

**(B) AHRS and ADC data path check (when GSU 75 installed)**

1. Verify there are no AHRS loss of data messages, such as:
  - AHRS not receiving any GPS information
  - AHRS not receiving backup GPS information
  - AHRS using backup GPS source
2. Place the G1000 system in configuration mode.
3. In the GIA page group, go to the GIA RS-232/ARINC 429 CONFIG page.
4. With GIA1 selected in the SELECT UNIT window, verify the following indicators are green checks (ref. Section 5.1.1):
  - RS232 Channel 1 (GDC72 #1)
  - RS232 Channel 6 (GRS79 #1)
  - ARINC 429 IN 6 (GSU75 #1)
5. With GIA2 selected in the SELECT UNIT window, verify the following indicators are green checks (ref. Section 5.1.1):
  - RS232 Channel 2 (GRS79 #1)
  - ARINC 429 IN 5 (GSU75 #1)
6. In the GDU page group, go to the GIA RS-232/ARINC 429 CONFIG page.

- 
7. With PFD1 selected in the SELECT UNIT window, verify the following indicators are green checks (ref. Section 5.1.1):
    - ARINC 429 IN1 (GSU75 #1)
    - ARINC 429 IN2 (GDC72 #1)
  
  8. With MFD selected in the SELECT UNIT window, verify the following indicators are green checks (ref. Section 5.1.1):
    - ARINC 429 IN1 (GSU75 #1)
    - ARINC 429 IN2 (GDC72 #1)
  
  9. Restart the G1000 in normal mode.

## 5. TROUBLESHOOTING

This section provides instructions and guidance for G1000 system troubleshooting as installed in the Cessna Nav III Series.

### **IMPORTANT!**

Sections 6, 7 and 9 provide detailed instructions on equipment removal, replacement, configuration, and return-to-service testing. Anytime a G1000 component or LRU is removed, swapped, or replaced, the technician must follow the procedures given in Sections 6, 7 and 9 to ensure proper operation of the system.

Troubleshoot the G1000 system by first identifying, then isolating the specific failure to the responsible LRU. There are several indications that the G1000 presents to the pilot or technician, showing overall system condition. A course of action should be determined based on the information presented on the display. This section shows possible scenarios likely to be encountered during normal operation and gives troubleshooting guidance to the technician to resolve problems.



Figure 5-1, Aux – System Status Page

The **Aux – System Status** page displays the following information for each LRU and sub-function:

- Status: A green check is displayed for properly operating LRUs. A red 'x' appears when an internal LRU fault is detected and it has taken itself offline, or if the MFD cannot communicate with the LRU.
- Serial Number: Each LRU serial number is displayed (functions such as COM and GS are contained within an LRU; therefore, serial numbers are not shown for these).
- Current SW Version Loaded.

When troubleshooting, first check to ensure that each LRU status is 'green' and that the correct software is loaded in each unit. Additional airframe and database information is also displayed on this page.

## 5.1 System Annunciations

If data fields become invalid due to an LRU failure, the PFD/MFD typically annunciates the failure with a large red X, as shown in Figure 5-2.

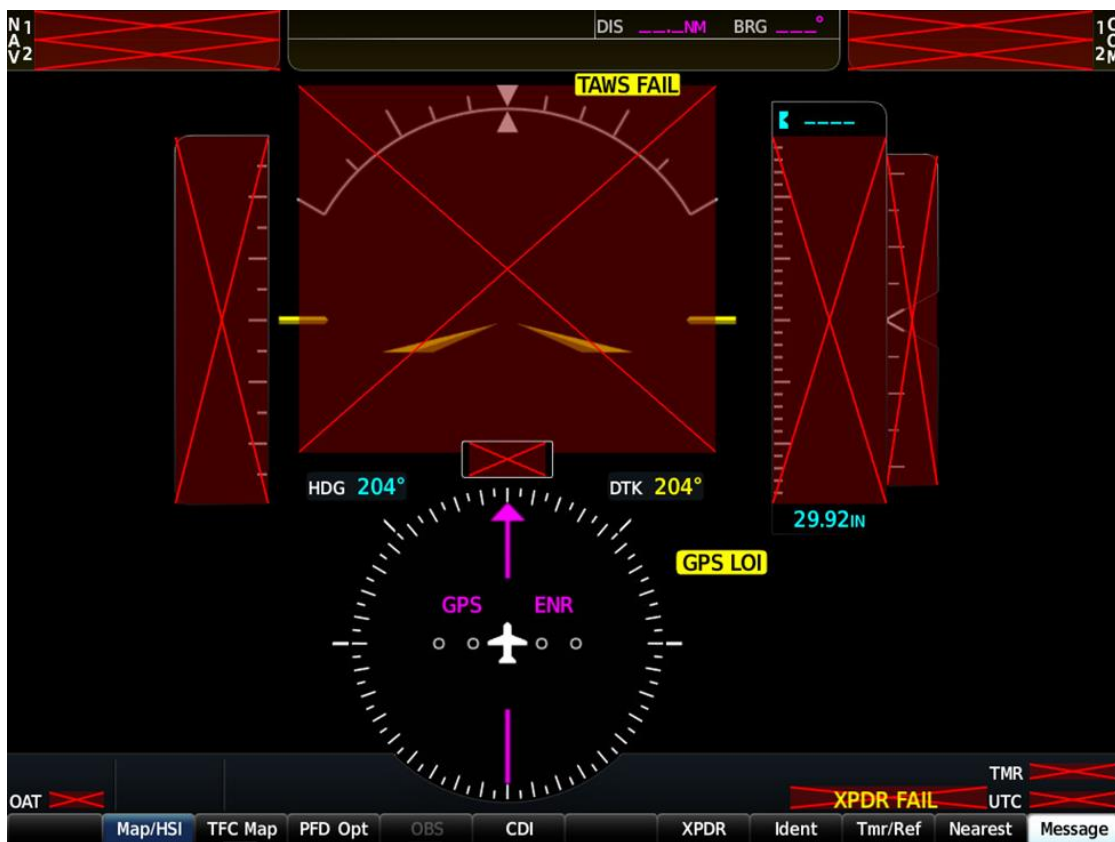

Figure 5-2, System Annunciations

---

### 5.1.1 Failed Path Messages

The following message indicates there is a data path connected to the GDU (PFD or MFD) or the GIA (1 or 2) that has failed.

FAILED PATH – A data path has failed.

The **FAILED PATH** message is triggered by a timeout of any one digital channel.

#### **IMPORTANT!**

**Once the FAILED PATH message has been triggered, it will remain on the list of messages until the next power cycle. This latching was implemented so that for intermittent failures, the message would remain at the end of the flight (to alert maintenance crew). Also, this keeps the crew from having to acknowledge message repeatedly in the case of intermittent failures.**

To determine which path is causing the **FAILED PATH** message, start the PFD and MFD in configuration mode. Using the FMS knobs, scroll to the pages listed below.

The channels that are checked are listed on these pages in config mode:

- 1) GDU RS-232 / ARINC 429 CONFIG (PFD and MFD)
- 2) GIA RS-232 / ARINC 429 CONFIG (GIA1 and GIA2)
- 3) GIA CAN / RS-485 CONFIGURATION (GIA1 and GIA2)

The box next to each channel indicates the current status of the channel per the below:

- Red X = data path is known to be failed
- Amber question mark (?) = data path status is unknown
- Green checkmark (✓) = data path is known to be good

The applicable data paths can be verified by viewing the following configuration mode pages.

#### **NOTE**

For paths not listed here, refer to the Cessna G1000 Nav III Line Maintenance Manual.

## GDU ARINC 429 CONFIG Page

### PFD and MFD ARINC 429

Channel	LRU	Indicator	Status
IN 1	GSU 75 #1 (if installed)	Green	PFD/GSU 75 data path is functioning correctly.
		Red	<p>PFD/GSU 75 data path is not functioning correctly.</p> <ul style="list-style-type: none"> <li>• Verify GSU 75 status is “OK” using the <b>Aux – System Status</b> page on the MFD. If it is not, correct condition before proceeding, reference GRS troubleshooting sections.</li> <li>• Load PFD configuration file.</li> <li>• Swap PFD and MFD to confirm if the problem is in the original PFD. <ul style="list-style-type: none"> <li>○ Replace original PFD if box turns green after swapping displays.</li> </ul> </li> <li>• Check the PFD/GSU 75 interconnect wiring for faults. <ul style="list-style-type: none"> <li>○ Replace the GSU75 if the problem persists.</li> </ul> </li> </ul>
		Amber	PFD/GSU 75 #1 data path functionality is unknown. Reload PFD configuration file.
IN 2	GDC 72 #1 (if GSU 75 installed)	Green	PFD/GSU 75 (ADC) data path is functioning correctly
		Red	<p>PFD/GSU 75 (ADC) data path is not functioning correctly.</p> <ul style="list-style-type: none"> <li>• Verify GDC status is “OK” using the <b>Aux – System Status</b> page on the MFD. If it is not, correct condition before proceeding, reference GSU troubleshooting sections.</li> <li>• Load PFD and GSU configuration files.</li> <li>• Swap PFD and MFD to confirm if the problem is in the original PFD. <ul style="list-style-type: none"> <li>○ Replace original PFD if box turns green after swapping displays.</li> </ul> </li> <li>• Check the PFD/GSU 75 interconnect wiring for faults. Replace GSU if problem remains.</li> </ul>
		Amber	PFD/GSU 75 (ADC) data path functionality is unknown. Reload PFD configuration file.

**GIA RS-232 / ARINC 429 CONFIG Page**

**GIA1 RS-232**

Channel	LRU	Indicator	Status
CHNL 1	GDC 72 #1 (if GSU 75 is installed)	Green	GIA1/GSU 75 (ADC) data path is functioning correctly.
		Red	<p>GIA1/GSU 75 (ADC) data path is not functioning correctly.</p> <ul style="list-style-type: none"> <li>• Load GIA1 and GSU configuration files.</li> <li>• Swap GIA1 and GIA2, reconfigure both GIA's to their new locations to confirm if the problem is in the original GIA1.                             <ul style="list-style-type: none"> <li>○ Replace original GIA1 if box turns green after swapping units.</li> </ul> </li> <li>• Check the GIA1/GSU 75 interconnect wiring for faults. Replace GSU 75 if problem remains.</li> </ul>
		Amber	GIA1/GSU 75 (ADC) data path functionality is unknown. Reload GIA1 configuration files.
CHNL 5	GTX 3x5R #1 (if GTX 335R or GTX 345R installed)	Green	GIA1/GTX 3X5R data path is functioning correctly.
		Red	<p>GIA1/GTX 3X5R data path is not functioning correctly.</p> <ul style="list-style-type: none"> <li>• Load GIA1 and GTX 335R or GTX 345R (as applicable) configuration files.</li> <li>• Swap GIA1 and GIA2, reconfigure both GIA's to their new locations to confirm if the problem is in the original GIA1.                             <ul style="list-style-type: none"> <li>○ Replace original GIA1 if box turns green after swapping units.</li> </ul> </li> <li>• Check the GIA1/GTX 3X5R interconnect wiring for faults. Replace GTX 335R or GTX 345R (as applicable) if problem remains.</li> </ul>
		Amber	GIA1/GTX 3X5R data path functionality is unknown. Reload GIA1 configuration files.
CHNL 6	GRS 79 #1 (if GSU 75 installed)	Green	GIA1/GSU 75 (AHRS) data path is functioning correctly.
		Red	<p>GIA1/GSU 75 (AHRS) data path is not functioning correctly.</p> <ul style="list-style-type: none"> <li>• Load GIA1 configuration files.</li> <li>• Swap GIA1 and GIA2, reconfigure both GIA's to their new locations to confirm if the problem is in the original GIA1.                             <ul style="list-style-type: none"> <li>○ Replace original GIA1 if box turns green after swapping units.</li> </ul> </li> <li>• Check the GIA1/GSU 75 interconnect wiring for faults.                             <ul style="list-style-type: none"> <li>○ Replace the GSU 75 if the problem persists.</li> </ul> </li> </ul>

		Amber	GIA1/GSU 75 (AHRs) data path functionality is unknown. Reload GIA1 configuration files.
--	--	-------	---

GIA1 ARINC 429

Channel	LRU	Indicator	Status
IN 6	GSU 75 #1 (if GSU 75 is installed)	Green	GIA1/GSU 75 (ADAHRs) data path is functioning correctly.
		Red	GIA1/GSU 75 (ADAHRs) data path is not functioning correctly. <ul style="list-style-type: none"> <li>• Load GIA1 configuration files.</li> <li>• Swap GIA1 and GIA2, reconfigure both GIA's to their new locations to confirm if the problem is in the original GIA1. <ul style="list-style-type: none"> <li>○ Replace original GIA1 if box turns green after swapping units.</li> </ul> </li> <li>• Check the GIA1/GSU 75 interconnect wiring for faults. <ul style="list-style-type: none"> <li>○ Replace the GSU 72 if the problem persists.</li> </ul> </li> </ul>
		Amber	GIA1/GSU 75 (ADAHRs) data path functionality is unknown. Reload GIA1 configuration files.

GIA2 RS-232

Channel	LRU	Indicator	Status
CHNL 2	GRS 79 #1 (if GSU 75 is installed)	Green	GIA2/GSU 75 (AHRs) data path is functioning correctly.
		Red	GIA2/GSU 75 (AHRs) data path is not functioning correctly. <ul style="list-style-type: none"> <li>• Load GIA2 and GSU configuration files.</li> <li>• Swap GIA2 and GIA1, reconfigure both GIA's to their new locations to confirm if the problem is in the original GIA1. <ul style="list-style-type: none"> <li>○ Replace original GIA2 if box turns green after swapping units.</li> </ul> </li> <li>• Check the GIA1/GSU 75 interconnect wiring for faults. <ul style="list-style-type: none"> <li>○ Replace GSU 75 if problem remains.</li> </ul> </li> </ul>
		Amber	GIA2/GSU 75 data path functionality is unknown. Reload GIA2 configuration files.
CHNL 5	GTX 3x5 #1	Green	GIA2/GTX 3X5R data path is functioning correctly.

Channel	LRU	Indicator	Status
		Red	<p>GIA2/GTX 3X5R data path is not functioning correctly.</p> <ul style="list-style-type: none"> <li>• Load GIA2 and GTX 335R or GTX 345R (as applicable) configuration files.</li> <li>• Swap GIA2 and GIA1, reconfigure both GIA's to their new locations to confirm if the problem is in the original GIA1. <ul style="list-style-type: none"> <li>○ Replace original GIA2 if box turns green after swapping units.</li> </ul> </li> <li>• Check the GIA2/GTX 3X5R interconnect wiring for faults.</li> <li>• Replace GTX 335R or GTX 345R (as applicable) if problem remains.</li> </ul>
		Amber	GIA2/GTX 3X5R data path functionality is unknown. Reload GIA2 configuration files.

GIA2 ARINC 429

Channel	LRU	Indicator	Status
IN 5	GSU 75 #1 (if GSU 75 is installed)	Green	GIA2/GSU 75 data path is functioning correctly.
		Red	<p>GIA2/GSU 75 data path is not functioning correctly.</p> <ul style="list-style-type: none"> <li>• Load GIA2 and GSU 75 configuration files.</li> <li>• Swap GIA2 and GIA1, reconfigure both GIA's to their new locations to confirm if the problem is in the original GIA2. <ul style="list-style-type: none"> <li>○ Replace original GIA2 if box turns green after swapping units.</li> </ul> </li> <li>• Check the GIA2/GSU 75 interconnect wiring for faults.</li> </ul> <p>Replace GSU 75 if problem remains.</p>
		Amber	GIA2/GSU 75 data path functionality is unknown. Reload GIA2 configuration files.

### 5.1.2 System Failure Troubleshooting

The following table provides basic troubleshooting guidance for LRU failures. Refer to G1000 Wiring Diagram, listed in Table 1-1, as needed to verify interconnects.

**NOTE:**

For troubleshooting of data fields and units not listed here, refer to the Cessna Nav III Line Maintenance Manual.

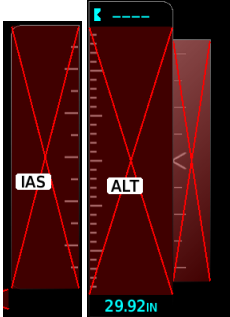
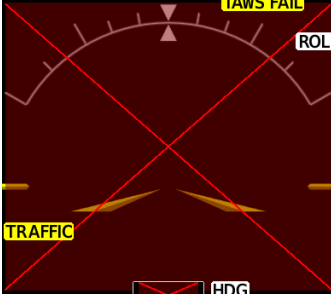
Invalid Data Field	Associated LRU(s)	Solution
<p>XPDR FAIL</p> 	<p>GTX 335R, GTX 345R (if installed)</p>	<ul style="list-style-type: none"> <li>• Check GTX configuration settings for GIA1 and GIA2.</li> <li>• Check GTX and GIA1 interconnect.</li> <li>• Check GTX and GIA2 interconnect.</li> <li>• Replace GTX.</li> <li>✓ If problem persists, replace GIA.</li> </ul>
<p>TAS FAIL AIRSPEED FAIL ALTITUDE FAIL VERT SPEED FAIL</p> 	<p>GSU 75 (if installed)</p>	<ul style="list-style-type: none"> <li>• Inspect GSU 75 pitot/static plumbing integrity.</li> <li>• Inspect pitot/static ports and associated equipment for faults.</li> <li>• For TAS failure, also check GTP 59 probe.</li> <li>• Check GSU 75 configuration settings for the PFD, MFD, GIA1, and GIA2.</li> <li>• If problem persists, replace the GSU 75.</li> </ul>
<p>ATTITUDE FAIL</p> 	<p>GSU 75 (if installed)</p>	<ul style="list-style-type: none"> <li>• Ensure that a cell phone or a device using cell phone technology is not turned on (even in a monitoring state) in the cabin.</li> <li>• Cycle GSU 75 power to restart initialization.</li> <li>• Ensure GSU 75 connector is secure and proper wire harness strain relief is provided.</li> <li>• Ensure the GSU 75 is fastened down tightly in its mounting rack and that the mounting rack is not loose (CAUTION - do not loosen the mounting rack hardware to the airframe shelf or the aircraft will need to be re-leveled and the PITCH/ROLL OFFSET procedure performed).</li> <li>• Ensure GPS has acquired at least four satellites, has a 3D navigation solution, and a DOP of less than 5.0. This is particularly important for an ATTITUDE FAIL that appears during ground operation only.</li> <li>• Perform an Engine Run-Up Test to check if engine vibration is causing the GSU 75 to go offline.</li> <li>• Load configuration files to the PFD, MFD, GIA1, and GIA2.</li> <li>• Calibrate the GSU 75 (Pitch/Roll Offset and Magnetometer Calibration).</li> <li>• Replace GSU 75.</li> <li>✓ If problem persists replace GSU 75 configuration module.</li> </ul>

Invalid Data Field	Associated LRU(s)	Solution
		<ul style="list-style-type: none"> <li>Contact Garmin Aviation Product Support if condition continues after replacing the GSU 75 and config module for additional assistance.</li> </ul>

## 5.2 G1000 Alerting System



**Figure 5-3, Alerts & Annunciations**

The G1000 Alert System conveys alerts to the pilot using combinations of the following features:

### Alert Window:

The Alert window displays alert text messages. Pressing the Alerts softkey displays the Alerts window. Pressing the ALERTS softkey again removes the Alerts window from the display.

### Softkey Annunciation:

When the G1000 Alerting System issues an alert, the Alerts softkey is used as a flashing annunciation to accompany the alert. During the alert, the Alerts softkey label flashes between white letters on black to black letters on a white. The flashing continues until the alert is acknowledged by a press of the Alerts softkey. The alerts softkey remains black letters on white until the condition causing the alert is corrected, or a new alert triggers the flashing.



**Figure 5-4, Alerts Softkey Annunciation**

### System Failure Annunciations:

---

Typically, a large red X appears in windows when a failure is detected in the LRU providing the information to the window.

### 5.3 Synthetic Vision and Pathways Troubleshooting

The SVS/Pathways software feature requires the following G1000 sensors/data to be valid:

- AHRS
- Heading
- GPS Position
- 9 Arc-Second (or less) Terrain Data

In the event that one the above items fails or is unavailable, the SVS/Pathways feature is automatically removed from the PFD. The following table describes possible symptoms associated with the SVS/Pathways feature, and provides corresponding actions for troubleshooting:

**Table 5-1, SVS Troubleshooting**

Symptom	Recommended Action
"SVT" softkey does not appear on PFD softkey tier.	Follow the steps in Section 3.8.2 to reactivate the SVS/Pathways feature.
3D terrain presentation does not appear on PFD.	<p>Verify that terrain database is current on the <b>Aux – Databases</b> page on the MFD.</p> <p>Verify that the alert messages shown in Table 5-2 are not displayed on the PFD Alerts Window. If so, follow the solutions described in Table 5-2.</p> <p>Verify that the G1000 AHRS and heading data are valid on the PFD. Verify that a valid GPS 3D position solution is being received. Troubleshoot these systems in accordance with the Cessna G1000 Nav III Line Maintenance Manual.</p> <p>If a terrain database update has just been performed, allow the system time to initialize and verify the data. When the databases have been verified, the current database cycle and version are reported on the MFD <b>Aux – System Status</b> and <b>Aux – Databases</b> page.</p>

The following table provides SVS/Pathways specific alert messages which may appear in the Alerts Window on the PFD (press the ALERTS softkey on the PFD to view the Alerts Window):

**Table 5-2, SVS-Related Alert Messages**

<b>Failure Message</b>	<b>Cause</b>	<b>Solution</b>
SVS – SVS DISABLED: Out of available terrain region.	SVS is disabled because the aircraft exceeded the boundaries of the loaded terrain database.	Geographical operation limitations are defined in the AFMS listed in Table 1-1. Ensure that operations are within this geographic area.

## 5.4 Backup Communications Path Checks

### 5.4.1 Overview

The G1000 system architecture is designed with redundant communication ports for several LRUs so that critical information can continue to be displayed in the event of an equipment or wiring failure. Of most importance is flight attitude, heading, and air data information. The GRS 77 and GDC 74A, or the GSU 75 (if installed) have two separate ARINC 429 data lines which are all capable of sending data to the displays. The GTX 335R or GTX 345R (if installed) have two redundant serial communication paths for the same purpose. See the Cessna Nav III Line Maintenance Manual for a basic G1000 block diagram depicting this architecture. Several other diagrams are shown later in this section for illustrative purposes. When troubleshooting, refer to the G1000 Wiring Diagram listed in Table 1-1.

#### **NOTE**

Refer to Section 9.6 for procedures on checking the status of each configured G1000 / GFC 700 backup data path.

### 5.4.2 Data Path Failures

<b>Failure Message</b>	<b>Cause</b>	<b>Solutions</b>
FAILED PATH – A data path has failed.	A communications data path status is not being received by the G1000.	Determine which data path has failed: See Section 5.1.1.  Check wiring continuity for the failed path.  Swap or replace the affected LRU.

## 5.5 GDU 105X Troubleshooting

### 5.5.1 GDU 105X Symptoms

<b>Symptom</b>	<b>Recommended Action</b>
Display is blank	<ul style="list-style-type: none"> <li>• Ensure that a cell phone or a device using cell phone technology is not turned on (even in a monitoring state) in the cabin.</li> <li>• Cycle power.                             <ul style="list-style-type: none"> <li>✓ If GDU recovers, observe display for yellow text containing error information at the top of the screen. If message indicates software need to be re-loaded, then re-load software. Otherwise, replace the GDU.</li> </ul> </li> <li>• Use a bright light to verify LCD is active.</li> </ul>

Symptom	Recommended Action
Display resets	<ul style="list-style-type: none"> <li>✓ Adjust avionics dimmer control full clockwise.</li> <li>✓ Manually turn up backlight on the PFD and load configuration files to the GDU.</li> <li>• Ensure slide lock is fully engaged with the locking tabs on the back of the unit. <ul style="list-style-type: none"> <li>✓ If slide lock is not fully engaged, remove connector and verify the locking tabs on the GDU are perpendicular to the connector. If necessary, straighten them before reseating connector.</li> </ul> </li> <li>• Ensure GDU is receiving power. If a circuit breaker is tripped, determine source of short before resetting breaker.</li> </ul>
Display flickers	<ul style="list-style-type: none"> <li>• Ensure circuit breakers have not failed and power wire connections are secure.</li> <li>• Swap PFD and MFD <ul style="list-style-type: none"> <li>✓ If problem follows unit, replace the display. Please note the position it failed in (PFD or MFD).</li> <li>✓ If problem does not follow unit, troubleshoot aircraft wiring for fault.</li> </ul> </li> </ul>
SD card is stuck in GDU	<ul style="list-style-type: none"> <li>• DO NOT insert a screwdriver of any length into the card slot.</li> <li>• DO NOT pry against the overlay.</li> <li>• DO NOT force the SD Card out.</li> <li>• Use a small screwdriver in the groove on the side of the exposed end of the card to help pull out the card.</li> <li>• Push the card in further to release the card locking mechanism.</li> <li>• Check SD Card for having more than one label. Two or more labels on the card will cause sticking. <ul style="list-style-type: none"> <li>✓ Remove all but one label.</li> </ul> </li> <li>• Ensure the SD card is from SanDisk. Use of other SD Cards is not recommended.</li> <li>• If card was inserted with the label facing to the right, do not attempt to remove. Return the unit to an authorized repair facility.</li> </ul>
A button/knob/joystick does not appear to function	<ul style="list-style-type: none"> <li>• Go to the GDU TEST page in configuration mode and verify button, knob, or joystick operates correctly by observing a change in color from red to green in the button/knob/joystick icon when the button/knob/joystick is pressed. If a button is stuck, the button icon will be green without pressing the button as soon as you turn to the GDU TEST page. <ul style="list-style-type: none"> <li>✓ If problem is verified, replace GDU.</li> </ul> </li> </ul>
Terrain/Obstacle/SafeTaxi does not display	<ul style="list-style-type: none"> <li>• Allow the system to verify the data in internal memory for approximately five minutes after power-up.</li> <li>• If a database does not activate, reload the problem database.</li> </ul>
Display will not track dimmer bus	<ul style="list-style-type: none"> <li>• Reload GDU configuration files.</li> <li>• Swap PFD and MFD to see if problem remains with display. <ul style="list-style-type: none"> <li>✓ Replace display if condition remains with the same unit.</li> <li>✓ If condition remains in original position after swapping displays, check GDU dimmer input to verify voltage is present.</li> </ul> </li> </ul>

## 5.6 GDU 105X Alerts

### 5.6.1 Software/Configuration Alerts

Failure Message	Cause	Solution
SW MISMATCH – GDU software version mismatch. Xtalk is off.	The system has found the PFD and MFD software versions do not match.	<ul style="list-style-type: none"> <li>• Load correct software version. See Section 3.7.2 for GDU 1050A Software Loading procedure.</li> </ul>
MANIFEST – PFD 1 software mismatch. Communication Halted.	The system has detected an incorrect software version loaded in the specified display.	
MANIFEST – MFD1 software mismatch. Communication Halted.		
CNFG MODULE – PFD 1 configuration module is inoperative.	The PFD master configuration module has failed.	<ul style="list-style-type: none"> <li>• Check master configuration module connector and wiring for damage inside the GDU connector backshell.               <ul style="list-style-type: none"> <li>✓ Replace master configuration module wiring and pins.</li> <li>✓ If problem persists, replace master configuration module.</li> </ul> </li> </ul> <p><b>NOTE</b></p> <p>New Terrain/Obstacle databases, Jeppesen Aviation Database and other optional features (i.e. TAWS unlock card) will need to be replaced if the master configuration module is changed. The G1000 System ID number will change to a new number when installing a new master config module. The old Terrain and other databases will no longer work as they will remain locked to the old System ID number.</p>

Failure Message	Cause	Solution
MFD1 CONFIG – MFD1 configuration error. Config service req'd.	A configuration mismatch has occurred between the display and the Master Configuration Module.	<ul style="list-style-type: none"> <li>• Reload the display configuration files from SD Loader Card.</li> <li>• Reload system configuration files by pressing the UPDT CFG softkey on the Configuration Upload Page in the PFD System Page Group to load configuration files into the configuration module.</li> <li>✓ If message persists, check PFD config module wiring for faults and replace if necessary.</li> <li>✓ If issue continues, replace PFD master configuration module.</li> <li>✓ If problem persists, replace the display.</li> </ul> <p style="text-align: center;"><b>NOTE</b></p> <p>New Terrain/Obstacle databases, Jeppesen Aviation Database and other optional features (i.e. TAWS unlock card) will need to be replaced if the master configuration module is changed. The G1000 System ID number will change to a new number when installing a new master config module. The old Terrain and other databases will no longer work as they will remain locked to the old System ID number.</p>
PFD 1 CONFIG – PFD 1 configuration error. Config service req'd.		

## 5.6.2 Key Alerts

Failure Message	Cause	Solution
MFD "key" KEYSTK – key is stuck.	The SYSTEM has determined a key is stuck on MFD.	<ul style="list-style-type: none"> <li>Go to the GDU TEST page in configuration mode and verify key is stuck (if key is stuck the corresponding indicator will be green).</li> </ul>
PFD "key" KEYSTK – key is stuck.	The system has determined a key is stuck on the PFD.	<ul style="list-style-type: none"> <li>Exercise suspected stuck key and reset GDU TEST page to see if indicator remains green without pressing the key. <ul style="list-style-type: none"> <li>✓ If problem persists replace the display.</li> </ul> </li> </ul>

## 5.6.3 Miscellaneous Alerts

Failure Message	Cause	Solution
XTALK ERROR – A flight display cross talk error has occurred.	A communication error has occurred between the MFD and PFD.	<ul style="list-style-type: none"> <li>Ensure a database error has not occurred (identified in the ALERTS window on the PFD). <ul style="list-style-type: none"> <li>✓ If a database error has occurred, correct error before proceeding.</li> </ul> </li> <li>Check display Ethernet interconnect wiring.</li> <li>Replace PFD with a known good unit, to verify location of problem: <ul style="list-style-type: none"> <li>✓ If problem persists, reinstall original PFD and replace MFD.</li> </ul> </li> </ul>
DATA LOST – Pilot stored data lost. Recheck settings.	Pilot stored data has been lost.	<ul style="list-style-type: none"> <li>If the CLR key was held during a power cycle, disregard message.</li> <li>Cycle power to PFD: <ul style="list-style-type: none"> <li>✓ Ensure CLR key is not stuck on the GDU TEST page.</li> <li>✓ If problem persists, replace PFD.</li> </ul> </li> </ul>

<b>Failure Message</b>	<b>Cause</b>	<b>Solution</b>
MFD SERVICE – needs service. Return unit for repair.	The G1000 has determined MFD needs service.	<ul style="list-style-type: none"> <li>• Ensure the MFD connector is fully seated and locked.</li> <li>• Replace the MFD.</li> <li>• Return faulty unit to an Authorized Repair Facility.</li> </ul>
PFD SERVICE – needs service. Return unit for repair.	The G1000 has determined the PFD needs service.	<ul style="list-style-type: none"> <li>• Ensure the PFD connector is fully seated and locked.</li> <li>• Replace the PFD.</li> <li>• Return faulty unit to an Authorized Repair Facility.</li> </ul>
PFD VOLTAGE – PFD has low voltage. Reducing power usage.	The specified PFD supply voltage is low.	<ul style="list-style-type: none"> <li>• Check input voltage to PFD.</li> <li>• If input voltage is ok, replace PFD.</li> </ul>
MFD VOLTAGE – MFD has low voltage. Reducing power usage.	The MFD supply voltage is low.	<ul style="list-style-type: none"> <li>• Check input voltage to MFD.</li> <li>• If input voltage is ok, replace MFD.</li> </ul>

## 5.7 GSU 75 and GMU 44 Troubleshooting

For troubleshooting of the GRS 77, refer to the G1000 Nav III Line Maintenance Manual.

### 5.7.1 AHRS Symptoms

Symptom	Recommended Action
ADAHRS does not complete initialization	<ul style="list-style-type: none"> <li>• Ensure that a cell phone or a device using cell phone technology is not turned on (even in a monitoring state) in the cabin.</li> <li>• Ensure GPS has acquired at least four satellites, has a 3D navigation solution, and a DOP of less than 5.0. This is particularly important if this issue appears during ground operation only.</li> <li>• Calibrate the GSU 75.</li> <li>• Check GSU 75 configuration module wiring for damage.</li> <li>• Check GSU 75 connector for bent pins. <ul style="list-style-type: none"> <li>✓ If no damage can be found, replace GSU 75 configuration module.</li> <li>✓ If problem persists, replace the GSU 75.</li> </ul> </li> </ul>
Attitude appears unstable	<ul style="list-style-type: none"> <li>• Ensure that a cell phone or a device using cell phone technology is not turned on (even in a monitoring state) in the cabin. (Wi-Fi and Bluetooth may be operational)</li> <li>• Ensure the two mounting jack screws are tight. Finger tight is not sufficient, a screwdriver must be used to verify.</li> <li>• Ensure mounting rack and airframe shelf are secure and all hardware and brackets are present (CAUTION - do not loosen the mounting rack hardware to the airframe shelf or the aircraft will need to be re-leveled and the PITCH/ROLL OFFSET procedure performed).</li> <li>• Ensure the GSU 75 connector is securely fastened and proper strain relief is provided.</li> <li>• Remove the GSU 75 connector and verify there are no bent pins.</li> <li>• Replace the GSU 75.</li> <li>• Contact Garmin for further troubleshooting if required.</li> </ul>

### 5.7.2 GSU Alerts

Failure Message	Cause	Solutions
MANIFEST – GRS software mismatch. Communication halted.	The system has detected an incorrect software version loaded in the specified GRS unit.	<ul style="list-style-type: none"> <li>• Load correct software version.</li> </ul>
AHRS SERVICE – AHRS magnetic-field model needs update.	The AHRS magnetic field model should be updated for the specified unit. Appears on ground only.	<ul style="list-style-type: none"> <li>• Load updated AHRS magnetic field file. See Section 4.5.</li> </ul>
GEO LIMITS – AHRS too far north/south, no magnetic compass.	No magnetic compass information available due to being too far north or south.	<ul style="list-style-type: none"> <li>• Operate the aircraft only within the limits as specified in the G1000 AFMS, listed in Table 1-2</li> </ul>
AHRS TAS – AHRS not receiving airspeed.	The GSU 75 AHRS card is not receiving airspeed from the internal air data card	<ul style="list-style-type: none"> <li>• Replace the GSU 75.</li> </ul>
AHRS GPS – AHRS not receiving backup GPS information.	The GSU 75 is not receiving backup GPS information from GIA 63 #2.	<ul style="list-style-type: none"> <li>• Ensure that a cell phone or a device using cell phone technology is not turned on (even in a monitoring state) in the cabin.</li> <li>• Check GPS status for GIA 1 and 2 on MFD <b>Aux – GPS Status</b> page. If</li> </ul>

<b>Failure Message</b>	<b>Cause</b>	<b>Solutions</b>
AHRS GPS – AHRS using backup GPS source.	The GSU 75 is using the backup GPS data path.	<p>one or both GPS receivers cannot acquire a position lock, see GPS troubleshooting section</p> <ul style="list-style-type: none"> <li>• Troubleshoot GIA1/2 –GSU wiring for faults (ref. Failed Path troubleshooting section).</li> <li>• Replace the GSU 75.</li> </ul>
MAG VAR WARN – Large magnetic variance. Verify all course angles.	Magnetic variance value from GMU 44 is not accurate.	<ul style="list-style-type: none"> <li>• If flying near large radio towers or other sources of possible electromagnetic interference, the condition should correct itself as the aircraft leaves the area.</li> <li>• If problem persists, run magnetic interference check in Section 5.7.4 to check for magnetic interference in the aircraft.</li> </ul>

### 5.7.3 GMU Alerts

<b>Failure Message</b>	<b>Cause</b>	<b>Solutions</b>
MANIFEST – GMU software mismatch. Communication halted.	The system has detected an incorrect software version loaded in the GMU 44.	Load the correct software version.
HDG FAULT – AHRS magnetometer fault has occurred	A fault has occurred in the magnetometer; heading will be flagged invalid.	<ul style="list-style-type: none"> <li>• Check GMU 44/GSU 75 interconnect for faults. <ul style="list-style-type: none"> <li>✓ Replace GMU 44.</li> <li>✓ If problem persists, replace GSU 75.</li> </ul> </li> </ul>

#### 5.7.4 Calibration Procedure E: Magnetometer Interference Test

A magnetometer interference test is available for troubleshooting and/or verifying a magnetically 'clean' installation of the GMU 44. This test exercises various devices on the aircraft that could potentially affect the magnetic field as measured by the GMU 44.

#### NOTE

This test is used to validate that no electronic device or magnetized components produce a magnetic field sufficient to interfere with the operation of the GMU 44 magnetometer. It is highly recommended that this test be performed after installation or maintenance of electrical components on the aircraft and/or for troubleshooting the GMU 44.

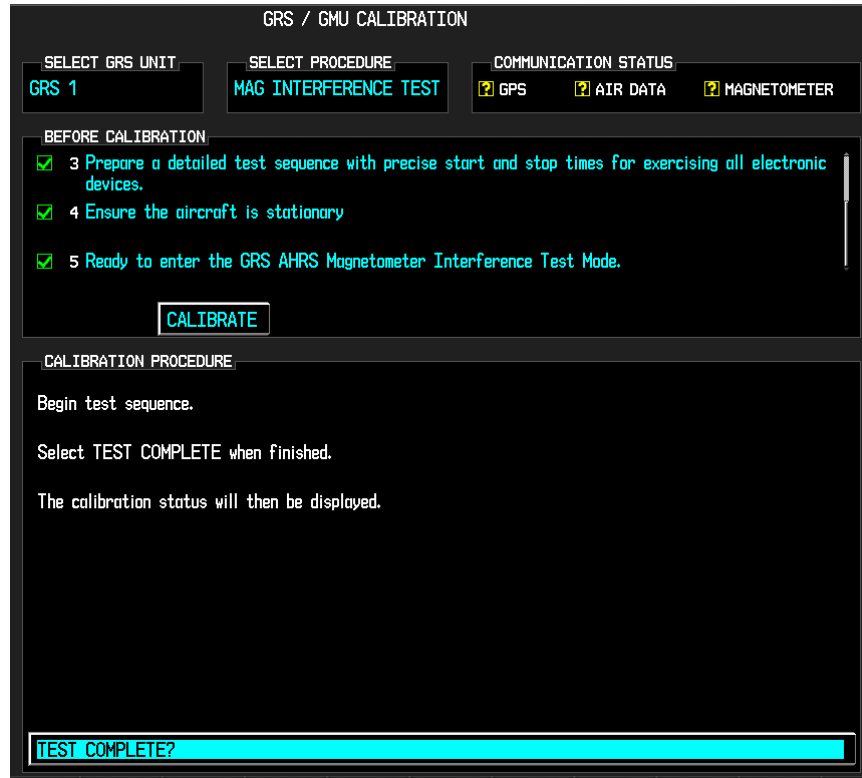

Figure 5-5, Magnetometer Interference Test

1. Initiate the AHRS magnetometer interference test procedure by performing the following steps:
2. On the PFD, enter Configuration Mode and go to GRS/GMU Calibration page as shown in Figure 5-5.
3. This page is protected and requires a keystroke password to perform this test. Press the following softkeys in sequence: (as counted from left to right on lower bezel of MFD)
  - softkey 9
  - softkey 10
  - softkey 11
  - softkey 12
4. Select MAG INTERFERENCE TEST and press the PFD ENT key.
5. Follow the checklist items displayed on the PFD, and press the ENT key as each one is completed or confirmed.

---

### NOTE

The 3<sup>rd</sup> item on the checklist instructs the operator to “prepare a detailed test sequence with precise start and stop times for exercising all electronic devices”. The list of relevant electronic devices is given in Table 5-3. Begin test with flaps retracted, flight controls in a neutral position, all lights selected OFF.

Elapsed Time since Start of Test (min:secs)	Action
0:00	Test begins
0:10	Navigation lights on
0:20	Navigation lights off
0:30	Landing lights on
0:40	Landing lights off
0:50	Recog/Taxi lights on
1:00	Recog/Taxi lights off
1:10	Strobes on
1:20	Strobes off
1:30	Beacon on
1:40	Beacon off
1:50	Pitot Heat on
2:00	Pitot Heat off
2:10	Aileron full right
2:20	Aileron full left
2:30	Flaps full down
3:00	Flaps full up
3:30	Rudder full left
3:40	Rudder full right
3:50	Elevator full nose UP
4:00	Elevator full nose DN
4:10	Elevator trim full nose UP (manual)
4:40	Elevator trim full nose DN (manual)
5:10	End of test

**Table 5-3, Magnetometer Interference Test Sequence**

6. When the CALIBRATE field is blinking, press the ENT key to begin the procedure, and have a stopwatch ready to begin recording the elapsed time.

**NOTE**

It is important that the “time equals zero” moment corresponds with the moment the PFD first displays the blinking TEST COMPLETE? Message.

**TEST COMPLETE?**

7. The operator should carry out the actions called for in the prepared test sequence.

**NOTE**

It is important that all actions are carried out in the order and at the precise elapsed time as specified in the prepared test sequence.

8. When the operator has completed the actions specified in the test sequence, press the ENTER button to indicate that the process is complete. When this is done, the TEST COMPLETE field stops blinking.
9. The PFD informs the operator if the installation has passed or failed the magnetometer interference test. If the test passes, no further action is required for this test.

If the test fails, the installation should be considered unreliable until the source of magnetic interference is identified and remedied. When the magnetometer interference test fails, record the three magnetometer maximum deviation values and their corresponding timestamps. Reference the installation manual for the GSU 75 (190-01639-00 for acceptable magnetic interference limits. Compare the corresponding timestamps with the prepared test sequence to identify which action produced the problem. Contact Garmin for assistance in resolving the problem.

**NOTE**

Two common reasons for a failed magnetometer interference test are: 1) new equipment is installed in close proximity to the GMU 44 magnetometer, and 2) an existing or new electronic device has become grounded through the aircraft structure instead of via the proper ground wire in a twisted shielded pair.

10. Press the ENT key on the PFD to conclude this procedure.

## **5.8 GSU 75 Troubleshooting**

### **5.8.1 Air Data Symptoms**

For GSU 75 Air Data Troubleshooting, refer to the GDC 74A section in the G1000 Nav III Line Maintenance Manual.

## 5.9 GTX Troubleshooting

### 5.9.1 GTX Alerts

Failure Message	Cause	Solutions
MANIFEST – GTX software mismatch. Communication halted.	The system has detected an incorrect software version loaded in the GTX unit.	<ul style="list-style-type: none"> <li>• Reload software.</li> </ul>
XPDR CONFIG – XPDR configuration error. Config service req'd.	The system has detected a configuration mismatch for the GTX unit.	<ul style="list-style-type: none"> <li>• Reload config files from a loader card.               <ul style="list-style-type: none"> <li>✓ If problem persists, replace master configuration module, check config module harness for faults and replace if necessary.</li> </ul> </li> </ul> <p><b>NOTE</b></p> <p>New Terrain/Obstacle databases, Jeppesen Aviation Database and other optional features (i.e. TAWS unlock card) will need to be replaced if the master configuration module is changed. The G1000 System ID number will change to a new number when installing a new master config module. The old Terrain and other databases will no longer work as they will remain locked to the old System ID number.</p>
XPDR SRVC – XPDR needs service. Return unit for repair.	The G1000 has detected a failure in the GTX	<ul style="list-style-type: none"> <li>• Replace GTX unit.</li> <li>• Return faulty unit to an Authorized Repair Facility.</li> </ul>
XPDR FAIL – XPDR is inoperative.	The GTX is not responding.	<ul style="list-style-type: none"> <li>• Check wiring between GIA's and GTX.</li> <li>• Replace GTX unit.</li> <li>• Return faulty unit to an Authorized Repair Facility.</li> </ul>
XPDR ADS-B FAIL – XPDR unable to transmit ADS-B message.	The GTX transponder is not able to transmit ADS-B data.	<ul style="list-style-type: none"> <li>• Check wiring between GIA's and GPS antenna.</li> <li>• Check wiring between GIA's and GTX.</li> </ul>

## 5.10 GDL 69A SXM Troubleshooting (if installed)



### 5.10.1 GDL 69A SXM Symptoms

Symptom	Recommended Action
<p>No XM audio is heard</p> <hr/> <p>No SiriusXM weather information is displayed</p>	<ul style="list-style-type: none"> <li>• Ensure the following items are not preventing the audio panel from distributing SiriusXM audio (reference applicable G1000 Pilot's Guide):               <ul style="list-style-type: none"> <li>√ Verify the SiriusXM volume is not muted on the AUX – XM RADIO page on the MFD.</li> <li>√ Verify the COM squelch is not open.</li> <li>√ Verify the ICS squelch is not open.</li> <li>√ Verify the marker beacon tones are not being received.</li> <li>√ Verify the headphone (if equipped) volume is turned up.</li> </ul> </li> <li>• Go to the AUX – SYSTEM STATUS page on the MFD and ensure unit is online.               <ul style="list-style-type: none"> <li>√ If a red X is present, verify the unit is receiving power at the rack connector.</li> </ul> </li> <li>• Ensure there are no GDL alerts in the alert window. If there is an Alert for software or configuration error or mismatch, reload the file noted in the Alert.</li> <li>• Restart the PFD's and MFD in configuration mode and go to the GDL page.               <ul style="list-style-type: none"> <li>√ Verify unit is active.</li> <li>√ Verify the Signal number is "2" or "3". If it is "0" or "1" check the GDL 69A antenna and cabling for faults.                   <ul style="list-style-type: none"> <li>√ Reseat the GDL69A SXM to verify the coax connector is fully seated.</li> </ul> </li> <li>√ If unit is not active, go to <a href="http://www.siriusxm.com/refresh">www.siriusxm.com/refresh</a> and enter your radio id numbers (there are two) to have a refresh signal sent to your unit. Also verify with SiriusXM that the correct Weather package (Aviator Lite or Aviator) is on the account, and that no traffic service has been activated against that Radio ID. The unit must be on for approximately one hour after the request for the refresh has been sent to receive the signal.</li> <li>√ If there is still problems receiving weather products after performing the above step, call SiriusXM for further troubleshooting on the SiriusXM account.</li> <li>√ Verify there is a good ground connection through the aircraft between the MFD and the GDL 69A SXM unit. Reference the Aircraft Maintenance Manual for instructions on how to check bonding and ground points.</li> <li>√ If problem persists, replace the GDL 69A SXM.</li> </ul> </li> </ul>

### 5.10.2 GDL 69A SXM Alerts

Failure Message	Cause	Solutions
GDL 69 FAIL – GDL 69 has failed.	The G1000 has detected a failure in the GDL 69A SXM.	<ul style="list-style-type: none"> <li>• Replace GDL 69A SXM.</li> <li>• Check GDL 69A SXM antenna and cabling.</li> <li>• Check the GDL 69A SXM and MFD interconnect.</li> </ul>
GDL69 CONFIG – GDL 69 configuration error. Config service req'd.	The G1000 has detected a GDL 69A SXM configuration mismatch.	<ul style="list-style-type: none"> <li>• Reload configuration file. See Section 7.3.1 for the Configuration Procedure.</li> <li>• If problem persists, replace master configuration module, check config module harness for faults and replace if necessary.</li> </ul> <p><b>NOTE</b> New Terrain/Obstacle cards, Jeppesen Aviation Database and other optional features (i.e. TAWS unlock card) will need to be replaced if the master configuration module is changed. The G1000 System ID number will change to a new number when installing a new master config module. The old Terrain and other cards will no longer work as they will remain locked to the old System ID number.</p>
MANIFEST – GDL software mismatch. Communication halted.	The system has detected an incorrect software version loaded in the GDL 69A SXM.	<ul style="list-style-type: none"> <li>• Load correct software version. See Section 7.3.1 for the Software Load Procedure.</li> </ul>

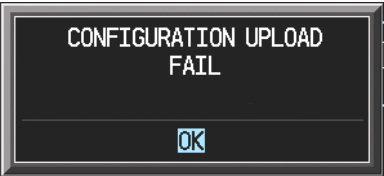
## 5.11 Software/Configuration Troubleshooting

Problem	Solutions
<p>MFD or PFD displays do not power up:</p>	<ul style="list-style-type: none"> <li>• Ensure that the criteria listed in Section 5.11.1 are fulfilled for the applicable situation.</li> <li>• Ensure power is present at display backshell connector.</li> <li>• Troubleshoot per the “Blank Display” GDU section.</li> </ul>
<p>Software file load fails:</p> 	<ul style="list-style-type: none"> <li>• Ensure that criteria listed in Section 5.11.1 are fulfilled for the applicable situation.</li> <li>• Ensure that LRU is reporting data on <b>Aux – System Status</b> page (LRU is ‘ONLINE’). Check data path wiring as needed.</li> <li>• Retry software file load or try using a different card. Ensure that the MFD is not touched during the loading process.</li> <li>• Ensure that LRU part number is compatible with software version and Card Loader. Refer to Section 3.2.3.</li> <li>• Replace LRU.</li> </ul>
<p>Configuration file load fails:</p> 	<ul style="list-style-type: none"> <li>• Ensure that the criteria listed in Section 5.11.1 are fulfilled for the applicable situation.</li> <li>• Ensure that LRU is reporting data on the <b>Aux – System Status</b> page (LRU is ‘ONLINE’). Check data path wiring as needed.</li> <li>• Retry configuration file load or try using a different card. Ensure that the MFD is not touched during the loading process.</li> <li>• Ensure that LRU part number is compatible with Card Loader. Refer to Section 3.2.3.</li> <li>• Replace LRU.</li> </ul>
<p>GIA1 and/or GIA2 to ‘LRU’ data path not working</p>	<ul style="list-style-type: none"> <li>• Ensure that the criteria listed in Section 5.11.1 are fulfilled for the applicable situation.</li> <li>• Ensure GIA1 and GIA2 are configured correctly.</li> <li>• Check wiring, connectors &amp; pins as needed.</li> </ul>
<p>Software File Mismatch Alert appears in lower right corner of PFD when started in normal mode:</p> 	<ul style="list-style-type: none"> <li>• Ensure that proper software file part number and version were loaded to LRU. Refer to Section 5.11.1.</li> <li>• Check and ensure that correct Card Loader was used during load process. Refer to the General Arrangement Drawing.</li> <li>• Reload software to LRU.</li> </ul>
<p>After being in configuration mode, the PFD displays a red AFCS annunciation and cycling of the transponder field between valid and invalid states.</p>	<ul style="list-style-type: none"> <li>• With the G1000 system powered on, open the MFD, PFD (ESS BUS), and PFD (AVN BUS 1) circuit breakers for approximately 30 seconds, then close the circuit breakers.</li> </ul>

### 5.11.1 System Communication Hierarchy

The following criteria must be satisfied to be able to perform the desired operation:

Desired Operation	Criteria for Success
Load Software to MFD or PFD Displays	<ul style="list-style-type: none"> <li>• SW Loader Card must be inserted in top slot for each display to be loaded.</li> <li>• ENT keys must be held during power up of display.</li> <li>• Power on only one display at a time during software loading.</li> </ul>
Load AIRFRAME, SYSTEM, MFD, PFD and MANIFEST configuration files to MFD and PFD	<ul style="list-style-type: none"> <li>• SW Loader Card must be inserted in top slot of PFD.</li> <li>• PFD and MFD must be powered on.</li> <li>• PFD and MFD must have correct software.</li> </ul>
Load Software/Configuration files to GIAs	<ul style="list-style-type: none"> <li>• SW Loader Card must be inserted in top slot of PFD.</li> <li>• G1000 system must be powered on.</li> <li>• PFD and MFD must have correct software.</li> <li>• PFD and MFD must be successfully configured with AIRFRAME, SYSTEM, MANIFEST, MFD and PFD configuration files.</li> </ul>
Load Software/Configuration files to: <ul style="list-style-type: none"> <li>- GMA 1347</li> <li>- GDC 74A (if installed)</li> <li>- GSU 75 (if installed)</li> <li>- GEA 71</li> <li>- GRS 77 (software only) (if installed)</li> <li>- GMU 44 (software only)</li> <li>- GTX 33 (if installed)</li> <li>- GTX 335R or GTX 345R (if installed)</li> </ul>	<ul style="list-style-type: none"> <li>• SW Loader Card must be inserted into PFD top slot.</li> <li>• G1000 must be powered on.</li> <li>• PFD and MFD must have correct software and configuration settings.</li> <li>• GIAs must have correct software.</li> <li>• GIAs must be successfully configured with GIA1 and GIA2 configuration files.</li> <li>• Data path from GIA1 to each LRU must be operational.</li> </ul>

## 5.12 Backshell/Backplate Connectors

The following figures depict the backplate connectors as viewed with the LRU removed. For units not shown here, refer to the G1000 Nav III Line Maintenance Manual.

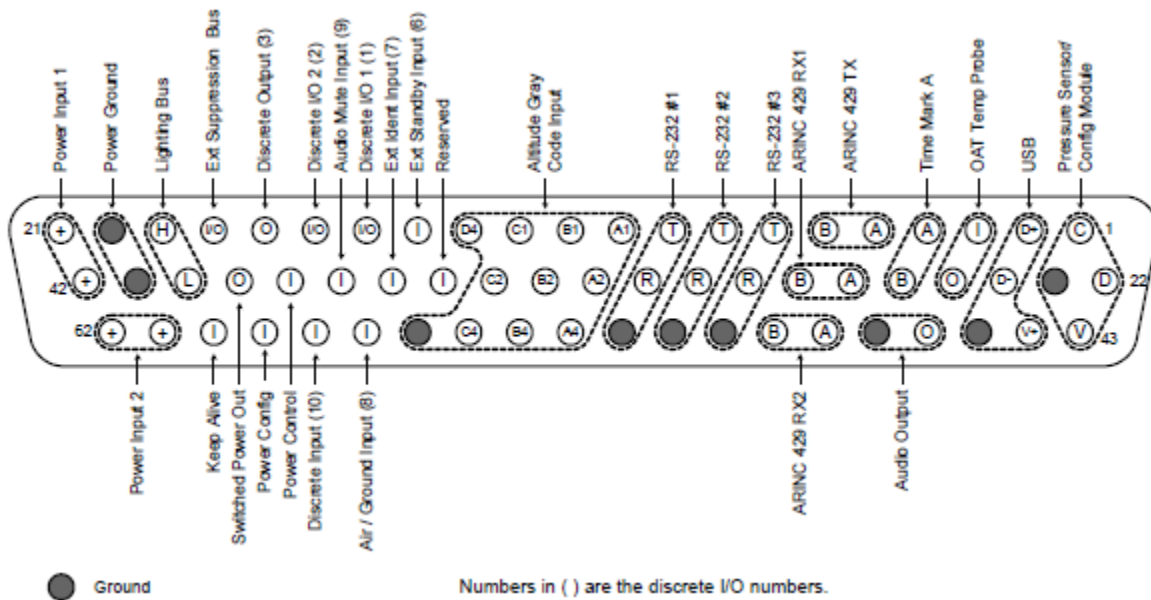

Figure 5-6, GTX 335R/345R Looking at Front of Connector (P3251)

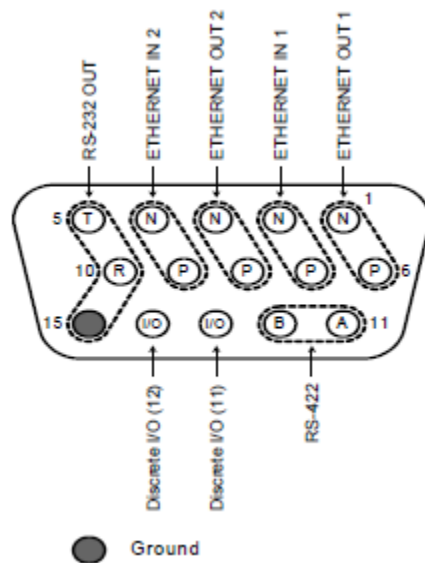
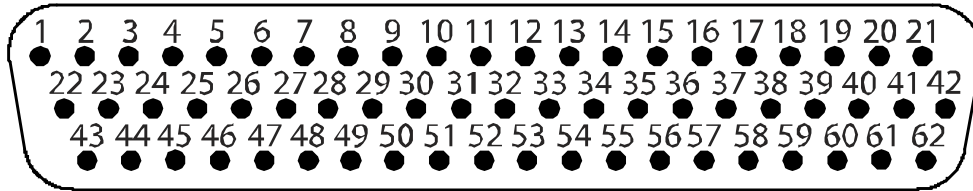
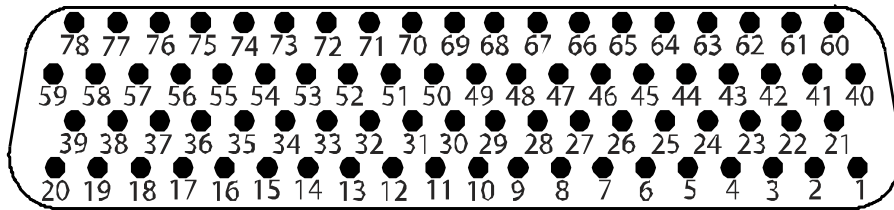

Figure 5-7, GTX 345R (Only) Looking at Front of Connector (P3252)



**Figure 5-8, GDU 1054B/1050 Backshell Connector (P10401)**



**Figure 5-9, GDL 69A SXM Backplate Connector (P69A1)**

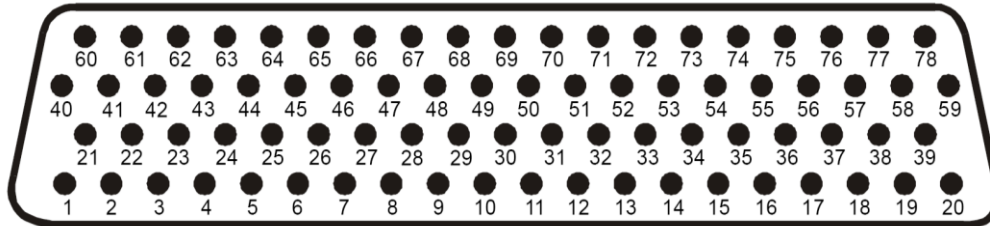

**Figure 5-10, GSU 75 Connector View from Front (P751)**

---

## 6. Equipment Removal & Installation

This section describes how to remove and replace equipment in the Cessna Nav III Series associated with this STC. After removal and replacement, LRUs must be configured and tested as described in Section 7.

### CAUTION:

**When removing and/or replacing any G1000 component, always ensure that aircraft power is off. Unplug any auxiliary power supplies. Before performing maintenance, it is required that the technician verify the LRU software part number and version number matches the software configuration listed in the General Arrangement drawing, listed in Table 1-1.**

### NOTE

After installation or maintenance of electrical components near the GMU 44 magnetometers, perform the Calibration Procedure E: Magnetometer Interference Test (reference Section 5) and Procedure B: GRS 77 and GMU 44 magnetic calibration, or GSU 75 and GMU 44 magnetic calibration – if installed (reference Section 7).

To check an LRU software part number and/or version, follow the procedure defined in Section 3.2.3.

If a faulty LRU is not reporting its software version and part number, check aircraft maintenance logs for last software version loaded and verify against the General Arrangement drawing. The Software Manifest page may also be used to check part numbers and versions.

The General Arrangement drawing allows alternate part number units to be installed with certain hardware/software combination restrictions. Refer to the applicable “Garmin Equipment/Software List” contained in the General Arrangement drawing for details.

---

## 6.1 GDU 1054B/1050

### Removal:

1. Using a 3/32" hex tool, rotate all four ¼-turn fasteners counter-clockwise until they reach their stops.
2. Carefully remove the display from the panel.
3. While supporting the display, disconnect the connector.

### Reinstallation:

1. Visually inspect the connector and pins for signs of damage. Repair any damage.
2. While supporting the display, connect the connector to the rear of the unit. Verify the connector is fully locked by rocking the connector up and down to verify the connector stays attached to the unit.
3. Carefully insert the display into the panel cutout, ensuring that all 4 ¼-turn fasteners align with the corresponding holes.
4. Seat the display in the panel cutout. Do not use excessive force while inserting the display.
5. Once seated, rotate all four ¼-turn fasteners clockwise to lock the display to the panel.
6. Configure and test the MFD and/or PFD according to Section 7.1.

## 6.2 GTX 335R/GTX 345R Transponder (if installed)

### GTX 335R/GTX 345R Removal:

1. Gain access to the aft avionics compartment in the tail of the aircraft.
2. Insert a 3/32" hex drive tool into the access hole in the front of the unit.
3. Turn hex drive tool counterclockwise until the hex drive tool stops.
4. Pull the unit from the rack using the spring-loaded tab on the front of the unit.

### GTX 335R/GTX 345R Reinstallation:

1. Visually inspect the connectors in the back of the rack to ensure there are no bent or damaged pins. Repair any damage if found.
2. Insert a 3/32" hex drive tool into the access hole in the front of the unit.
3. Turn hex drive tool counterclockwise until the hex drive tool stops.
4. Slide the unit in the rack until it stops. The unit will appear to stick out of the rack approximately 3/8".
5. Insert a 3/32" hex drive tool into the access hole in the front of the unit.
6. Push on the left side of the unit and turn hex drive tool clockwise until it stops. Do not apply more than 8 in-lbs of torque on the hex tool to seat the unit.
7. Configure and test the GTX 335R or GTX 345R according to Section 7.2.

---

### 6.3 GDL 69A SXM (if installed)

#### Removal:

1. For 182 and 206 aircraft, gain access by removing the right side GDU 1054B display unit (see Section 6.1.)
2. For 172 aircraft, gain access to the aft avionics compartment in the tail of the aircraft.
3. Unlock the GDL 69A handle by loosening the Phillips screw on the handle.
4. Pull the handle upward to unlock the GDL 69A. Gently remove the unit from the rack.

#### Reinstallation:

1. Visually inspect the connectors to ensure there are no bent or damaged pins. Repair any damage.
2. Lift the handle and gently insert the GDL 69A into its rack. The handle should engage the dogleg track.
3. Press down on the GDL 69A handle to lock the unit into the rack.
4. Lock the handle to the GDL 69A body using the Philips screw. Torque the handle screw to 10-14 in-lbs.
5. Configure and test the GDL 69A according to Section 7.3.

### 6.4 GSU 75 ADAHRS

#### GSU 75 Removal:

1. Gain access to the aft avionics compartment in the tail of the aircraft.
2. Disconnect the ADAHRS connector.
3. Disconnect the pitot and static lines.
4. Turn each retention screw counterclockwise until they disconnect from the remote rack.
5. Gently slide the unit from the remote rack. Do NOT loosen the remote rack hardware fastening it to the avionics shelf or the GSU 75 must be re-calibrated per Section 7.5

#### GSU 75 Installation:

1. Visually inspect the connector to ensure there are no bent or damaged pins. Also inspect the pitot and static fittings for damage. Repair any damage.
2. Place the GSU 75 unit on the remote rack and slide the unit back until the feet are fully engaged with the remote rack.
3. Push down and turn each retention screw clockwise. Torque each retention screw to 15-20 in-lbs.
4. Connect the pitot and static lines.
5. Connect the ADAHRS connector to the unit.
6. Calibrate and test the GSU 75 per Section 7.5.

## 6.5 Configuration Module

### 6.5.1 GDU Configuration Module Removal & Replacement

Configuration modules (Reference Figure 6-1 and Table 6-1, Item 1 shown below) are located in the following LRU harness connector backshells: GDU 1054B or GDU 1050 PFD. Additionally, the GSU 75 has different style configuration modules that are located in the connector backshells. Refer to Section 6.5.3 for the GSU 75 configuration module removal and replacement instructions. Refer to the Master Drawing List, listed in Table 1-1, for specific installation drawings.

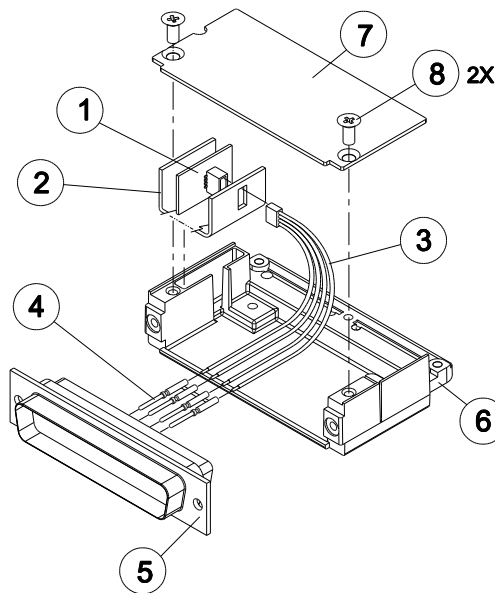

Figure 6-1, Configuration Module Installation

Table 6-1, Configuration Module Kit – 011-00979-00

Item	Description	Qty Needed	Garmin Part Number
1	Configuration Module PCB Board Assembly w/EEPROM & Temp Sensor	1	012-00605-00 or -02
2	Spacer, Config Module	1	213-00043-00
3	Cable, 4-Conductor Harness	1	325-00122-00
4	Pins, #22 AWG (HD)	5	336-00021-00

#### Removal:

1. Disconnect connector from LRU.
2. Remove 2 screws (8) from cover (7) and remove cover.
3. Unplug connector from configuration module (1).
4. Remove configuration module.

#### Installation:

1. Inspect connector for damaged pins (4).
2. Place configuration module (1) in position.
3. Insert connector into configuration module (1).

4. Assembly of the connector is the reverse of disassembly.
5. Checkout per Section 6.5.4.

### 6.5.2 GTX 3X5R Configuration Module Removal & Replacement

GTX 3X5R series transponders require the installation of a configuration module. The configuration module is installed in the connector assembly, as shown in Figure 6-2.

**Table 6-2, Configuration Module Kit – 011-00979-03**

Item	Description	Qty Needed	Garmin Part Number
1	Configuration Module PCB Board Assembly w/EEPROM	1	011-02178-00
2	Cable, 4-Conductor Harness	1	325-00122-00
3	Pins, #22 AWG (HD)	4	336-00021-00

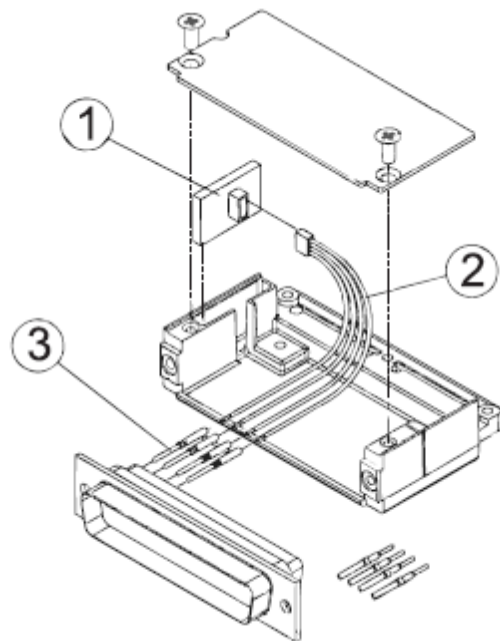

**Figure 6-2, Configuration Module Installation**

**Removal:**

1. Disconnect connector from LRU.
2. Remove 2 screws from cover and remove cover.
3. Unplug connector from configuration module (1).
4. Remove configuration module.

**Installation:**

1. Inspect connector for damaged pins (3).
2. Crimp pin contacts (3) onto each wire of the 4-conductor wire harness (2). Strip 0.17 inches of insulation from each wire prior to crimping.
3. Insert newly crimped pin contacts and wires (2, 3) into the correct locations in the connector housing.

4. Plug the 4-conductor wire harness (2) into the connector on the PCB board (1).
5. Insert PCB board (1) into the backshell recess.
6. Orient the connector housing so that the inserted 4-conductor wire harness (2) is on the same side of the backshell, as the inserted PCB board (1).

### 6.5.3 GSU 75 Configuration Module Removal & Replacement

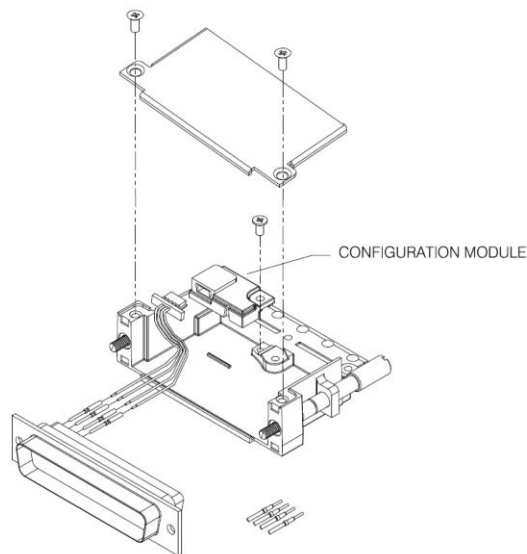

**Figure 6-3, GSU 75 Configuration Module Installation**

**Table 6-3, GSU 75 Configuration Module Kit – 011-00979-20**

Item	Description	Qty Needed	Garmin Part Number
1	Sub-Assy,Potted,Config Mdl,w/EEPROM,Jackscrow	1	011-02179-00
2	Cable, 4-Conductor Harness	1	325-00122-00
3	Pins, #22 AWG (HD)	4	336-00021-00
4	Pan Head Screw	1	211-60232-07

**Removal:**

1. Disconnect connector from LRU.
2. Remove 2 screws from cover and remove cover.
3. Unplug the connector from the configuration module.
4. Remove 1 screw from configuration module.
5. Remove the configuration module.

**Installation:**

1. Inspect connector for damaged pins.
2. Insert the connector into the configuration module.

- 
3. Place configuration module in position.
  4. Install 1 screw attaching the configuration module to the backshell.
  5. Assembly of the connector is the reverse of the disassembly.
  6. Checkout per Section 6.5.4.

---

## 6.5.4 Configuration Module Checkout

### If a GSU 75 Configuration Module is replaced:

Configuration settings must be reloaded to the GSU 75 per Section 7.4 ,then proceed to Section 7.4.4.

Additionally, GSU 75 and GMU 44 calibration procedures must be performed. Proceed to Section 7.5.

### If only the Master (PFD) Configuration Module is replaced:

#### **NOTE**

New Terrain/Obstacle databases, Jeppesen Aviation Database and other optional features (i.e. unlock/enablement cards) will need to be replaced if the master configuration module is changed. The G1000 System ID number will change to a new number when installing a new master config module. The old databases and feature enable cards will no longer work as they will remain locked to the old System ID number.

1. Start the G1000 system in configuration mode.
2. Go to the Configuration Upload Page on the PFD.
3. Press the UPDT CFG softkey and press ENT.

### If both the PFD and Master Configuration Module are replaced:

#### **NOTE**

New Terrain/Obstacle databases, Jeppesen Aviation Database and other optional features (i.e. unlock/enablement cards) will need to be replaced if the master configuration module is changed. The G1000 System ID number will change to a new number when installing a new master config module. The old databases and feature enable cards will no longer work as they will remain locked to the old System ID number.

1. The entire G1000 system must be re-configured. Insert the correct G1000 software loader card into the PFD.
2. Start the G1000 in configuration mode. Go to the System Upload Page on the PFD.
3. See Section 3.7 for instructions on how to use the System Upload page. Check all configuration files and reload them.
4. After reloading configuration files, examine the G1000 installation for any installed configuration options. Options are listed in Section 3.7. Load optional files as necessary.
5. Continue to Section 9 and conduct the return to service checkout.

---

## 6.6 FS 510 Wifi/Bluetooth Data Link (if installed)

### Removal:

1. FS 510 card is installed in the bottom slot of the MFD.
2. Press the edge of the card and release to remove card.

### Reinstallation:

1. Insert FS510 card in the bottom slot of the MFD.

---

## 7. Garmin G1000 LRU Replacement/Configuration & Testing

This section provides procedures to be followed after a piece of G1000 equipment is replaced. At the beginning of each LRU section, instructions are given to guide the technician for various removal/replacement scenarios. These instructions define necessary procedures to be followed for situations where original equipment was reinstalled as well as for situations where new equipment (new serial number) is installed.

### NOTE

Only SanDisk brand SD cards are recommended for use with the G1000 system. Other brand cards have not been tested for use with the G1000 system.

### CAUTION

**Connect a ground power unit to the aircraft for software loading. DO NOT RELY ON THE AIRCRAFT BATTERY TO LOAD SOFTWARE. DO NOT USE A BATTERY CHARGER AS AN EXTERNAL POWER SOURCE DUE TO ELECTRICAL NOISE IT MAY INJECT IN THE G1000 SYSTEM. DO NOT ALLOW POWER TO BE REMOVED FROM THE SYSTEM WHEN LOADING SOFTWARE! Remove power only when told to do so by the following procedure.** Power loss during a software upgrade may cause an LRU to become corrupted and unresponsive requiring replacement. Remove power only when told to do so in the procedure.

**All displays should be in the same mode (configuration or normal), unless instructed differently.**

**If an incorrect configuration file is loaded at any time in this section, STOP and start the configuration load over using Section 3.7.**

### 7.1 GDU 1054B/1050 PFD & MFD

#### Original Display Reinstalled

If the removed display(s) are re-installed in their original positions, no software or configuration loading is required. This does not include units that were returned for repair as their software and configuration files are deleted during the repair testing process. Continue to the PFD/MFD Test procedure, Section 7.1.5.

#### Original Displays Installed in Opposite Locations for Troubleshooting

If the PFD and MFD are installed in opposite positions, no software or configuration loading is required. Continue to the PFD/MFD Test procedure, Section 7.1.5.

#### New Repair or Exchange Display(s) Installed

If a new, repaired or exchanged GDU is installed, the correct software and configuration files must be loaded to the unit.

---

### 7.1.1 LRU Replacement Procedure PFD

1. Open the MFD, PFD (ESS BUS), and PFD (AVN BUS 1) circuit breakers.
2. Remove SD cards from top and bottom slots of the MFD and PFD if present.
3. Apply power to the G1000 system by connecting external power to the aircraft to energize the aircraft and avionics electrical busses.
4. Turn on Avionics/electrical busses.
5. Power on the MFD and PFD in configuration mode.
6. Using the MFD, scroll to the LRU replacement page.
7. Activate the cursor and select PFD in the LRU dropdown box.
8. Press the **CHK All** softkey.
9. Press the **Load** softkey.
10. Press **ENT** to acknowledge the process was complete.
11. Deactivate the cursor.
12. Scroll to the Configuration Manager page.
13. Press the **CNFM CFG** softkey.
14. Select ok when prompted to “Confirm configuration as expected configuration”
15. Power cycle the system verify there are no red-Xs or system alerts.
16. If red-Xs or system alerts are present, troubleshoot as necessary using Section 5 or re-load the system using the legacy method in Section 3.7.
17. If there are no red-Xs or system alerts, continue to Section 7.1.5.

### 7.1.2 Legacy Replacement Procedure PFD (Alternate Method)

A full system configuration re-load is required when a new, repaired, or exchanged display is installed using this method. This includes all options and feature enablements.

To complete this procedure, continue to Section 3.7.

### 7.1.3 LRU Replacement Procedure MFD

#### NOTE

Anytime the MFD is replaced, all databases must be reloaded.

1. Open the MFD, PFD (ESS BUS), and PFD (AVN BUS) circuit breakers.
2. Remove SD cards from top and bottom slots of the MFD and PFD if present.
3. Apply power to the G1000 system by connecting external power to the aircraft to energize the aircraft and avionics electrical busses.
4. Turn on Avionics electrical busses.
5. Power on the MFD and PFD in configuration mode.
6. Using the PFD, scroll to the LRU replacement page.
7. Activate the cursor and select MFD in the LRU dropdown box.

8. Press the **CHK All** softkey.
9. Press the **Load** softkey.
10. Press **ENT** to acknowledge the process was complete.
11. Deactivate the cursor.
12. Scroll to the Configuration Manager page.
13. Press the **CNFM CFG** softkey.
14. Select ok when prompted to “Confirm configuration as expected configuration”
15. Power cycle the system verify there are no red-Xs or system alerts.
16. If red-Xs or system alerts are present, troubleshoot as necessary using Section 5 or re-load the system using the legacy method in Section 3.7.
17. Install databases as directed in Section 3.12.
18. After databases are re-loaded, continue to Section 7.1.5.

#### 7.1.4 Legacy Replacement Procedure MFD (Alternate Method)

A full system configuration re-load is required when a new, repaired, or exchanged display is installed using this method. This includes all options and feature enablements. To complete this procedure, perform Section 3.7.

#### 7.1.5 PFD/MFD Test

1. Allow displays to initialize for ~1 minute.
2. Check that all COM/NAV display fields are valid in the top corners of the PFD.
3. Check that attitude, heading, altitude, airspeed, vertical speed and OAT fields are valid within 2 minutes of power up on the PFD.
4. Check that the engine instrument fields are valid on the MFD.



**Figure 7-1, G1000 Normal Mode Check**

5. Push the red DISPLAY BACKUP button on the GMA. Verify that the PFD and MFD displays enter reversion mode. MFD should have valid altitude, airspeed, vertical speed, COMM1, COMM2, NAV1, NAV2 and engine instruments.
6. De-activate pilot-side reversion mode by pushing the DISPLAY BACKUP button. Verify the PFD and MFD return to normal display modes.

- 
7. Select the **Map – TAWS Map** page on the MFD.
  8. Verify that the title at the top of the page reads “Map – TAWS-B”. If TAWS has not been enabled, the title will read “**Map – Terrain Proximity**” or “**Map – Terrain**”.
  9. Press the MENU button and select “Test TAWS” from the pop-up menu.
  10. After the TAWS test has completed, verify that “TAWS System Test Okay” is heard over the cockpit speaker.
  11. If no other service is to be performed, perform final return-to-service test as specified in Section 9.

## 7.2 GTX 335R or GTX 345R Transponder

### Original GTX is Reinstalled

No software or configuration loading is required if the removed GTX 335R or GTX 345R is re-installed. This does not include units that were returned for repair as their software and configuration files are deleted during the repair testing process. Continue to GTX 335R or GTX 345R Test Section 7.2.3.

### New, Repaired or Exchange GTX is Installed

If a new, repaired or exchange GTX 335R or GTX 345R is installed, the correct software and configuration files must be loaded to the unit. See Section 7.2.1.

### 7.2.1 LRU Replacement Procedure GTX1

1. Open the MFD, PFD (ESS BUS), and PFD (AVN BUS) circuit breakers.
2. Remove Garmin SD/MMC/FS 510 cards from bottom slots of the MFD and PFD if present.
3. Apply power to the G1000 system by connecting external power to the aircraft to energize the aircraft and avionics electrical busses.
4. Turn on Avionics electrical busses.
5. Power on the MFD and PFD in configuration mode.
6. Using the PFD, scroll to the LRU replacement page.
7. Activate the cursor and select GTX1 in the LRU dropdown box.
8. Press the **CHK All** softkey.
9. Press the **Load** softkey.
10. Press **ENT** to acknowledge the process was complete.
11. Deactivate the cursor.
12. Scroll to the Configuration Manager page.
13. Press the **CNFM CFG** softkey.
14. Select ok when prompted to “Confirm configuration as expected configuration”
15. Power cycle the system verify there are no red-Xs or system alerts.
16. If red-Xs or system alerts are present, troubleshoot as necessary using Section 5 or re-load the system using the legacy method in Section 7.2.2.

- 
17. If there are no red-Xs or system alerts, continue to Section 7.2.3.

## 7.2.2 Legacy Replacement Procedure GTX (Alternate Method)

1. Insert the software loader card in the top slot of the PFD.
2. Power on the MFD and PFD in configuration mode.
3. Select no when “Do you want to update system files” is displayed on the screen of the PFD.
4. Select the “**SYSTEM UPLOAD**” page using the small FMS knob on the PFD.
5. Activate cursor and rotate the small FMS knob to display the drop down menu. Rotate the large FMS knob to highlight “**0X - XXX**” (where 0X is the menu position and XXX is the airframe type) and press **ENT** key on the PFD.
6. Rotate the small FMS knob to display the drop down menu. Rotate the large FMS knob to highlight one of the following options (as applicable) and press ENT key on the PFD:

**Baseline Option – GTX 335 Installation**

**Baseline Option – GTX 345 Installation, without GTS 800**

**Baseline Option – GTX 345 Installation, with GTS 800**

**Option – GTX 345R Installation, with KTA870**~~(as applicable). Press ENT key on the PFD.~~

7. Press the **CLR ALL** softkey.
8. Use the large FMS knob to scroll to GTX.
9. Highlight the software box(es) and press the **ENT** key to check the box.
10. Highlight the Configuration box and press the **ENT** key to check the box.
11. Press “**Load**” softkey.
12. Monitor load progress. Verify software load completes without errors as indicated by the following:
  - Green “PASS” in the Configuration and Software columns for each item loaded.
  - “Upload Complete.....”“COMPLETE” in the summary box.
13. Acknowledge the prompt by pushing the **ENT** key.
14. Deactivate the cursor.
15. Scroll to the Configuration Manager page.
16. Press the **CNFM CFG** softkey.
17. Select ok when prompted to “Confirm configuration as expected configuration”
18. Power cycle the system verify there are no red-Xs or system alerts.
19. If red-Xs or system alerts are present, troubleshoot as necessary using Section 5.
20. If there are no red-Xs or system alerts, continue to Section 7.2.3.

### 7.2.3 GTX 335R or GTX 345R Test

Operation of the GTX 335R or GTX 345R Mode-S transponder is accomplished using the PFD or the MFD. Refer to G1000 Cessna Nav III Cockpit Reference Guide, listed in Table 1-1, for basic operation.

The integrated transponder/altitude reporting system must be verified in accordance with Title 14 of the Code of Federal Regulations (14 CFR) §§ 91.411 and 91.413, **every 24 calendar months**, or any time the transponder is removed. This test requires the use of a Mode S ramp generator. Specific instructions for operating the ramp tester are contained in the applicable operator's manual. Refer to 14 CFR Part 43 Appendices E and F for testing criteria.

#### NOTE

The GTX 3X5R must be placed in a simulated airborne state to perform the tests of FAR 91.413.

To simulate a temporary airborne state, place the GTX 3X5R in Ground Test mode. Ground Test mode overrides the air/ground logic to transmit as if the GTX is airborne. This mode has a duration of one power cycle.

#### To enable Ground Test mode:

1. Place the PFD in config mode and the MFD in normal mode. Place the entire system in reversionary mode (this allows the transponder code and mode indications to be observed when selecting ground test mode).
2. On the Aircraft Configuration page (Figure 7-2), there is a softkey labeled 'GND Test' which is only enabled when the aircraft is detected to be on the ground. The white color of the XPDR code and mode on the PFD also indicates on-ground.



Figure 7-2, GTX Ground Test Mode Softkey

3. Press the "GND Test" softkey to activate the ground test mode. The system forces the XPDR state to airborne, as indicated by the green color of the transponder code and mode on the PFD.

- 
4. Cycle power on the PFD only to return it to normal mode. Wait for the XPDR code and mode to return to green and for GPS to re-acquire.
  5. Perform the procedures in FAR 91.413 to test the transponder.

### NOTE

CFR 91.413 transponder checks require the GTX to reply to different types of interrogations. The GTX 335R and GTX 345R only reply to Mode S/A/C All Calls when airborne.

6. To deactivate the ground test mode, cycle power to the system. It will resume normal air ground detection after testing.
7. If no other service is to be performed, continue to the return-to-service checks in Section 9.

### ADS-B Out Testing

### NOTE

Prior to performing transponder testing, contact the local Air Traffic Control (Center and Approach) and inform them of your intention to perform transponder and ADS-B Out testing. Hangar doors do not provide adequate isolation from ATC.

1. Power up the MFD in normal mode.
2. Power up the PFD in configuration mode.
3. Scroll to the aircraft configuration page on the PFD.
4. Press the GND Test softkey on the PFD.
5. Open PFD circuit breaker.
6. Close PFD circuit breaker. The transponders are now in an in-air-condition.
7. Verify "TRANSPONDER - ADSB is not transmitting position" annunciation is not present on the PFD ALERTS window.
8. Using an appropriately equipped Transponder Ramp Test Set, verify the LAT and LON data reported by the transponders corresponds to the data displayed on the MFD AUX - GPS Status page.
9. Garmin equipment reports LAT and LONG values in hddd°mm'.mm format, whereas some Transponder Ramp Test Sets require LAT and LONG to be entered in hddd.mm'ss.s". Convert the Garmin reported position prior to entering it in the test set.

Example:

GIA reported Latitude = 38°.51'.34

TR-220 Latitude = 38°.51'.20.4" (.34 \* 60 (seconds in a minute) = 20.4)

10. Open PFD and MFD circuit breakers.
11. Close PFD and MFD circuit breakers.
12. If no other service is to be performed, continue to the return-to-service checks in Section 9.

---

### 7.3 GDL 69A SXM Data Link (if installed)

#### Original GDL 69A SXM is Reinstalled

No software or configuration loading is required if the removed GDL 69A SXM is re-installed. This does not include units that were returned for repair as their software and configuration files are deleted during the repair testing process. Continue to the GDL 69A SXM Test Section 7.3.3.

#### New, Repaired or Exchange GDL 69A SXM is Installed

If a new, repaired or exchange GDL 69A SXM is installed, the correct software and configuration files must be loaded to the unit, then the SiriusXM Satellite Radio subscription must be reactivated. See the SiriusXM Activation Instructions listed in Table 1-2.

#### 7.3.1 LRU Replacement Procedure

1. Open the MFD, PFD (ESS BUS), and PFD (AVN BUS 1) circuit breakers.
2. Remove Garmin SD/MMC/FS 510 cards from bottom slots of the MFD and PFD if present.
3. Apply power to the G1000 system by connecting external power to the aircraft to energize the aircraft and avionics electrical busses.
4. Turn on Avionics electrical busses.
5. Power on the MFD and PFD in configuration mode.
6. Using the PFD, scroll to the LRU replacement page.
7. Activate the cursor and select GDL69 in the LRU dropdown box.
8. Press the **CHK All** softkey.
9. Press the **Load** softkey.
10. Press **ENT** to acknowledge the process was complete.
11. Deactivate the cursor.
12. Scroll to the Configuration Manager page.
13. Press the **CNFM CFG** softkey.
14. Select ok when prompted to "Confirm configuration as expected configuration"
15. Power cycle the system verify there are no red-Xs or system alerts.
16. If red-Xs or system alerts are present, troubleshoot as necessary using Section 5.
17. If there are no red-Xs or system alerts, continue to Section 7.3.3.

#### 7.3.2 Legacy Replacement Procedure GDL69 (Alternate Method)

1. Insert the software loader card in the top slot of the PFD.
2. Power on the MFD and PFD in configuration mode.
3. Select no when "Do you want to update system files" is displayed on the screen of the PFD.
4. Select the "SYSTEM UPLOAD" page using the small FMS knob on the PFD.

- 
5. Activate cursor and rotate the small FMS knob to display the drop down menu. Rotate the large FMS knob to highlight "0X – XXX" (where 0X is the menu position and XXX is the airframe type) and press **ENT** key on the PFD.
  6. Rotate the small FMS knob to display the drop down menu. Rotate the large FMS knob to highlight "**Baseline Option – GDL 69A SXM Installation**" as applicable. Press **ENT** key on the PFD.
  7. Press the **CLR ALL** softkey.
  8. Using the large FMS knob scroll down to the GDL software box and press **ENT**.
  9. Scroll down to the GDL configuration box and press **ENT**.
  10. Press the **Load** softkey.
  11. Monitor load progress. Verify software load completes without errors as indicated by the following:
    - Green "PASS" in the Configuration and Software columns for each item loaded.
    - "Upload Complete.....COMPLETE" in the summary box.

**NOTE**

If the software load fails, cycle power to the GDL 69A only and confirm that the software part number and version are updated in the DATA window on the MFD. Then, press ENT button on the PFD to check the GDL 69A SXM SOFTWARE and CONFIGURATION check boxes and press LOAD softkey again to resume the software update.

12. Press **ENT** key on the PFD to acknowledge upload complete.
13. Deactivate cursor.
14. Scroll to the Configuration Manager page.
15. Press the **CNFM CFG** softkey.
16. Select ok when prompted to "Confirm configuration as expected configuration"
17. Power cycle the system verify there are no red-Xs or system alerts.
18. If red-Xs or system alerts are present, troubleshoot as necessary using Section 5.
19. If there are no red-Xs or system alerts, continue to Section 7.3.3.

---

### 7.3.3 GDL 69A SXM Test

If a SiriusXM Satellite Radio subscription has already been activated for the GDL 69A SXM, then power up the G1000 and go to the **Aux – Information** page and verify that the GDL 69A SXM is working properly. Refer to the Cockpit Reference Guide, listed in Table 1-2, for details on Sirius XM Radio weather and music operation.

If the GDL 69A SXM is replaced (new unit), the owner must re-activate the subscription, using the new GDL 69A SXM's Radio ID number(s). Refer to the GDL 69A SXM Satellite Radio Activation Instructions, listed in Table 1-2, for details on the activation process.

As a final operations check, make sure there are no MANIFEST errors shown on the PFD for the GDL 69A SXM.

If no other service is to be performed, continue to the return-to-service checks in Section 9.

### 7.4 GSU 75 ADAHRS (if installed)

#### Original GSU unit is Reinstalled

No software or configuration loading is required if the removed GSU 75 is re-installed. This does not include units that were returned for repair as their software and configuration files are deleted during the repair testing process. Perform a pitot - static system leak check and continue to Section 9.

#### New, Repaired or Exchange GSU unit is Installed

If a new, repaired or exchange GSU unit is installed, the correct software and configuration files must be loaded to the unit.

#### New GSU 75 Configuration Module is Installed

The correct configuration files must be loaded if the GSU75 configuration module has been replaced.

#### 7.4.1 LRU Replacement Procedure GSU

1. Open the MFD PFD (ESS BUS), and PFD (AVN BUS 1) circuit breakers.
2. Remove Garmin SD/MMC/FS 510 cards from bottom slots of the MFD and PFD if present.
3. Apply power to the G1000 system by connecting external power to the aircraft to energize the aircraft and avionics electrical busses.
4. Turn on Avionics electrical busses.
5. Power on the MFD and PFD in configuration mode.
6. Using the PFD, scroll to the LRU replacement page.
7. Activate the cursor and select GRS1 in the LRU dropdown box.
8. Press the **CHK All** softkey.
9. Press the **Load** softkey.
10. Press **ENT** to acknowledge the process was complete.
11. Select GDC 1 in the LRU dropdown box.
12. Press the **CHK All** softkey.

- 
13. Press the **Load** softkey.
  14. Press **ENT** to acknowledge the process was complete.
  15. Deactivate the cursor.
  16. Scroll to the Configuration Manager page.
  17. Press the **CNFM CFG** softkey.
  18. Select ok when prompted to “Confirm configuration as expected configuration”
  19. Power cycle the system verify there are no red-Xs or system alerts.
  20. If red-Xs or system alerts are present, troubleshoot as necessary using Section 5 or re-load the system using the legacy method in Section 7.4.2.
  21. If there are no red-Xs or system alerts, continue to Section 7.4.4 for the air data portion of the GSU and Section 7.4.3 for the AHRS portion of the GSU.

#### **7.4.2 Legacy Replacement Procedure GSU (Alternate Method) (if installed)**

1. Insert the software loader card in the top slot of the PFD.
2. Power on the MFD and PFD in configuration mode.
3. Select no when “Do you want to update system files” is displayed on the screen of PFD.
4. Select the “**SYSTEM UPLOAD**” page using the small FMS knob on the PFD.
5. Activate cursor and rotate the small FMS knob to display the drop down menu. Rotate the large FMS knob to highlight “**0X - XXX**” (where 0X is the menu position and XXX is the airframe type) and press **ENT** key on PFD.
6. Rotate the small FMS knob to display the drop down menu. Rotate the large FMS knob to highlight “**Baseline Option – GSU75 Installation**”. Press **ENT** key on PFD.
7. Press the **CLR ALL** softkey.
8. Use the large FMS knob to scroll to GSU - AHRS.
9. Highlight the software box and press the **ENT** key to check the box.
10. Highlight the Configuration box and press the **ENT** key to check the box.
11. Use the large FMS knob to scroll to GSU – ADC.
12. Highlight the software box and press the **ENT** key to check the box.
13. Highlight the Configuration box and press the **ENT** key to check the box.
14. Press “**Load**” softkey.
15. Monitor load progress. Verify software load completes without errors as indicated by the following:
  - Green “PASS” in the Configuration and Software columns for each item loaded.
  - “Upload Complete.....”COMPLETE” in the summary box.
16. Acknowledge the prompt by pushing the **ENT** key.
17. Deactivate the cursor.
18. Scroll to the Configuration Manager page.
19. Press the **CNFM CFG** softkey.

20. Select ok when prompted to “Confirm configuration as expected configuration”
21. Power cycle the system verify there are no red-Xs or system alerts.
22. If red-Xs or system alerts are present, troubleshoot as necessary using Section 5.
22. If there are no red-Xs or system alerts, continue to Section 7.4.4 for the air data portion of the GSU and Section 7.4.3 for the AHRS portion of the GSU.

### 7.4.3 GSU/GMU Test

Start the displays in normal mode. The ADAHRS/AHRS attitude and heading information displayed should become valid within 1 minute of power-up as shown in Figure 7-3 if at least one GPS receiver has a valid position. If GPS is unavailable, the ADAHRS/AHRS initialization may take up to 2 minutes.

### 7.4.4 Air Data Test (GSU 75 or GDC 74A)

The G1000 system must be maintained in accordance with the G1000 System Maintenance Manual listed in Table 1-2 and appropriate regulations. When the GDC unit is tested in accordance with 14 CFR Part 43, Appendix E, note the following exceptions:

- Do not perform paragraph (b)(1)(iv) Friction
- Do not perform paragraph (b)(1)(vi) Barometric Scale Error

The following Air Data Test is to be performed in addition to or in conjunction with any other regulated tests. This test must be performed with a calibrated Air Data Test Set (ADTS) with a combined accuracy/repeatability specification of less than  $\pm 20$  feet for the test altitude range.

1. For GSU 75 installations, gain access to the aft avionics compartment in the tail of the aircraft. Locate the tee fittings in the pitot and static lines just forward of the GSU 75 and remove the capped nuts. Drain any condensation from the lines and tees. Reinstall the capped nuts onto the tees and tighten, ensuring caps are facing downward.

NOTE: If tee fittings are not installed in the pitot and static lines, disconnect the lines directly from the GSU 75 and drain any condensation from the lines. Reconnect the pitot and static lines to the GSU 75 and tighten the nuts.

2. Perform pitot static system leak check as described in Chapter 34 of the appropriate Cessna Maintenance Manual (refer to Table 1-1 for Manual details.)
3. Connect the pitot/static tester to the aircraft pitot and static ports.
4. Verify that the PFD altimeter baro setting is set to 29.92 in Hg (1013.25 mb).
5. Start the PFD in configuration mode and navigate to the GRS page. The values for altitude and airspeed are shown on the AHRS/AIR DATA INPUT table as B ALT and IAS for AIR DATA 1.
6. Simulate the altitudes shown in Table 7-1. Wait for ADTS to report that target values have been achieved.
7. On Table 7-1, record the altitude (B ALT) displayed on the PFD for AIR DATA 1 for each altitude.
8. Simulate the airspeeds shown in Table 7-1.
9. On Table 7-2, record the airspeed (IAS) displayed on the PFD for AIR DATA 1 for each airspeed.

10. Verify that the indicated altitudes and airspeeds are within allowable tolerances.

11. File the results with the aircraft maintenance records.

If either the pilot or copilot air data system does not meet the tolerances specified, have maintenance checks performed on the air data system or the pitot/static system.

**Table 7-1, Altitude Test Points**

Test Set Altitude	PFD Altitude Reading (from B ALT field)	Allowed Tolerance
0		+/- 20
500		+/- 20
1000		+/- 20
1500		+/- 20
2000		+/- 20
4000		+/- 25
8000		+/- 30
11000		+/- 35
14000		+/- 40
17000		+/- 45
20000		+/- 50

**Table 7-2, Airspeed Test Points**

Test Set Airspeed	PFD Airspeed Reading (from IAS field)	Allowed Tolerance
50		+/- 5.0
80		+/- 3.0
100		+/- 2.0
120		+/- 2.0
150		+/- 2.0
180		+/- 2.0



**Figure 7-3, Normal Mode AHRS Check**

If no other service is to be performed, continue to the return-to-service checks in Section 9.

## 7.5 GSU/GMU Calibration Procedures

### GSU/GMU Recalibration Criteria

The following calibration procedures are provided for the GRS/GSU and GMU 44:

- Pitch/Roll Offset: (Procedure A1, provided in section 7.5.1)
- Magnetometer Calibration: (Procedure B, provided in section 7.5.3)
- Engine Run-Up Vibration Test: (Procedure D, provided in section 7.5.4)
- Magnetometer Interference Test: (Procedure E, provided in section 5.7.4)

Follow the steps given for each procedure on-screen at the GRS/GMU CALIBRATION page. Note that the CALIBRATE command cannot be selected and activated until the installer acknowledges all required steps have been carried out by pressing the ENT key on each step.

**Table 7-3, Required GRS/GMU Calibrations**

Condition	Calibrations Required		
	Procedure A1: GSU 75 Pitch/Roll Offset	Procedure B: GSU/GMU Magnetic Calibration	Procedure D: Engine Run-up Vibration Test
GMU 44 was removed and reinstalled. (no change in serial number)	None Required. Continue to GSU /GMU Test Section.		
GMU 44 was replaced with new unit. (New serial number)		X	
GRS AHRS or GSU ADAHRS was removed and/or replaced. The mounting tray was NOT removed and the mounting tray bolts were NOT loosened.	None Required. Continue to GSU/GMU Test Section.		
GRS AHRS or GSU ADAHRS was removed and/or replaced. The mounting tray WAS removed and/or mounting tray bolts WERE loosened.	X	X	X
GRS AHRS or GSU ADAHRS Configuration Module was replaced.	X	X	X

### 7.5.1 Procedure A1: GSU 75 or GRS 77 Pitch/Roll Offset Calibration

This first procedure must be carried out with the engine off.

1. Level the aircraft to within  $\pm 0.25^\circ$  of zero pitch and zero roll. (Follow instructions in the appropriate Cessna Nav III Series Maintenance Manual, listed in Table 1-1, for leveling)
2. Start the PFD in Configuration mode.
3. Go to the GRS Page Group and select the GRS/GMU Calibration page at the PFD. This page is protected and the following softkey password must be entered at the PFD to continue:
  - 9
  - 10
  - 11
  - 12 (Far Right softkey)

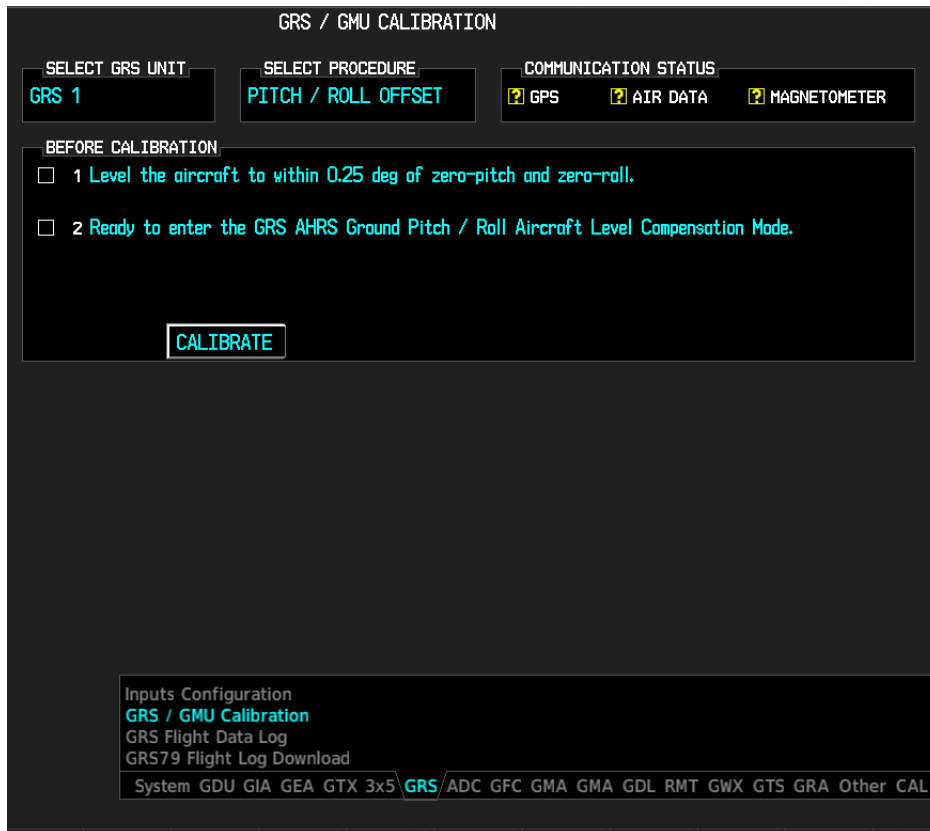

Figure 7-4, GRS/GMU Calibration, Pitch/Roll Offset

#### NOTE

On the calibration pages, “GRS” includes GRS and GSU units.

4. Ensure that the GRS 1 is selected in the SELECT GRS UNIT window on the PFD.
5. Activate the cursor and highlight the SELECT PROCEDURE window and select PITCH / ROLL OFFSET.

- 
6. Press the ENT key.
  7. Use the cursor to highlight Step 1 in the BEFORE CALIBRATION window.
  8. Follow the checklist items displayed on the PFD and press the ENT key as each step is completed or confirmed.
  9. When the CALIBRATE field is blinking, press the ENT button to begin the procedure.
  10. After several seconds, a new checklist appears in the lower half of the PFD. Press the ENT key as each step is confirmed. When the CONFIRM AIRCRAFT IS LEVEL field is blinking, press the ENT key to continue.
  11. The result of the pitch/roll offset compensation is displayed on the PFD. If successful, the AHRS records the required pitch and roll offsets, informs the operator of a successful conclusion and returns to normal operation.
  12. Press the ENT key on the PFD to conclude this procedure for GRS 1.

---

## 7.5.2 Compass Rose Evaluation of Magnetic Disturbances for Magnetometer Calibration Procedure (Optional)

### NOTE

The Magnetometer Calibration Procedure that follows in Section 7.5.3 (Calibration Procedure B) must be carried out at a site that is determined to be free of magnetic disturbances. If it is unsure whether the site is 'clean', the technician should verify that the site is 'clean' by following the guidance provided in Section 7.5.2. The technician may skip Section 7.5.2 if the site condition is acceptable.

Typically, a compass rose is an acceptable location to perform the magnetometer calibration procedure. However, because not all compass roses are well maintained, even an existing compass rose should be regularly evaluated using the method described here to determine if it is free of magnetic disturbances. If evaluation of an existing compass rose indicates that magnetic disturbances are present, then an alternative location must be found to perform the Magnetometer Calibration Procedure.

A G1000-equipped airplane that has completed the pitch/roll offset compensation procedure (Procedure A-1, Section 7.5.1) can be used to evaluate a candidate site for magnetic disturbances and determine whether it is a suitable location to perform the magnetometer calibration procedure. The magnetometer calibration procedure itself contains the logic to simultaneously survey the location for magnetic cleanliness while it is computing the magnetometer calibration parameters.

In order to evaluate a candidate site, the Magnetometer Calibration Procedure must be performed twice: once turning clockwise around the site, and once turning counter-clockwise. Both times, the procedure should be conducted as described in Section 7.5.3 of this document, with the exception of the direction of turns around the site.

### NOTE

Although Section 7.5.3 indicates that the Magnetometer Calibration Procedure should be performed by making a series of clockwise turns around the site, the procedure can also be performed by making counter-clockwise turns for the purpose of evaluating the site for magnetic disturbances.

If the PFD displays the "CALIBRATION SUCCESSFUL / SITE IS CLEAN" message upon completion of the Magnetometer Calibration Procedure in each clockwise and counter-clockwise direction, then the candidate site is sufficiently free of magnetic disturbances and is acceptable for performing the Magnetometer Calibration Procedure. It is important to obtain successful result in both the clockwise and counter-clockwise directions to ensure that the magnetometer sweeps over a large enough area at the candidate site.

If the PFD displays either the "MAG FIELD AT SITE NOT UNIFORM" or "MAG FIELD AT SITE DIFFERS FROM IGRF MODEL" message upon completion of the Magnetometer Calibration Procedure in either of the two directions, then the site contains magnetic disturbances that are too large.

---

### 7.5.3 Procedure B: GSU 75 and GMU 44 Magnetic Calibration

#### NOTES

Procedure A-1 (Section 7.5.1) must first be successfully accomplished before performing Procedure B, only for situations where the GSU was replaced with a new unit.

On the calibration pages, “GRS” refers to whichever GRS or GSU unit is installed.

1. Start the aircraft engine following the procedures referenced in the appropriate Cessna Nav III AFM as listed in Table 1-1.
2. After aircraft engine startup, taxi the aircraft to a properly calibrated compass rose.
3. At the compass rose, align the aircraft to a heading of magnetic north ( $\pm 5^\circ$ ).

#### CAUTION

Calibration Procedure B must be carried out on a compass rose in order to guarantee measurements free of environmental magnetic disturbances. Attempting to carry out this maneuver on a typical ramp area may not yield a successful calibration. The accuracy of the AHRS/ADAHRS cannot be guaranteed if this calibration is not performed on a magnetically clean compass rose or equivalent. If the compass rose condition is not known, it is recommended that the technician follow the guidance in Section 7.5.2.

4. Restart the PFD in configuration mode.
5. Go to the GRS Page Group on the PFD.
6. Select the GRS/GMU Calibration page and enter the following softkey password:
  - 9
  - 10
  - 11
  - 12 (far right softkey)
7. Use the FMS small knob to highlight GRS/GSU for calibration and press the ENT key.
8. Using the FMS small knob, select MAGNETOMETER. Press the ENT button.
9. Use the cursor to highlight the first step in the BEFORE CALIBRATION window.
10. Follow the checklist items displayed on the PFD and press the ENT key as each one is completed or confirmed. When the CALIBRATE field is blinking, press the ENT key to begin the procedure.
11. The PFD display advises the operator when to turn the aircraft, when to stop, and when to turn again.
12. Upon instruction to turn, taxi the aircraft in a right turn. After approximately  $25^\circ$  to  $30^\circ$  of turn from the last heading, the PFD display advises the operator to stop the aircraft.

#### NOTE

Due to the difficulties in executing smooth, accurate turns the PFD may incorrectly interpret a station and instruct to “HOLD POSITION” prior to full

---

completion of a 30° turn. If this scenario is encountered, it is best for the operator to ignore the “HOLD POSITION” command and instead use outside references to complete the approximate 30° turn. Instead of using the PFD instruction to turn as a real-time indication of when to turn, simply judge the 30° ( $\pm 5^\circ$ ) turn increments of the aircraft by using the compass rose radials. Dwelling at these 30° increments for the time recommended by the PFD should result in successful calibration.

13. The PFD guides the operator to dwell at multiple headings around a complete circle.

**NOTE**

Due to high winds or excessive airframe vibration, the operator may encounter a condition where the PFD restarts the 18-second countdown without full completion of the previous countdown. If this is encountered more than once for a given station, the operator should begin turning to the next station (approximately 30°). A minimum of 2 successful stations per quadrant is required, where a successful station is a full 18-second countdown followed by instruction to move. Ensure that at least 2 stations per quadrant are completed. Thus, it may sometimes be required to dwell at a station after a countdown restart. A maximum of 30 stations is allowed for the entire calibration procedure. If too many countdown restarts are encountered, the calibration will fail with the message, “TOO MANY STATIONS.”

14. Repeat the turn-and-stop process until the PFD advises that a successful calibration is complete. The GRS AHRS/GSU ADAHRS then enters its normal operational mode. Press the ENT button on the PFD to conclude this procedure.

## 7.5.4 Procedure D: Engine Run-Up Vibration Procedure

### NOTES

On the calibration pages, “GRS” refers to whatever GRS or GSU unit is installed.

Calibration Procedure D is performed in order to guarantee that the ADAHRS/AHRS mounting is sufficiently rigid and insensitive to vibration. This procedure must be performed for both GSU/GRS units installed in the aircraft. Calibration Procedures A1 and B (Sections 7.5.1 and 7.5.3 respectively) are not required prior to this procedure.

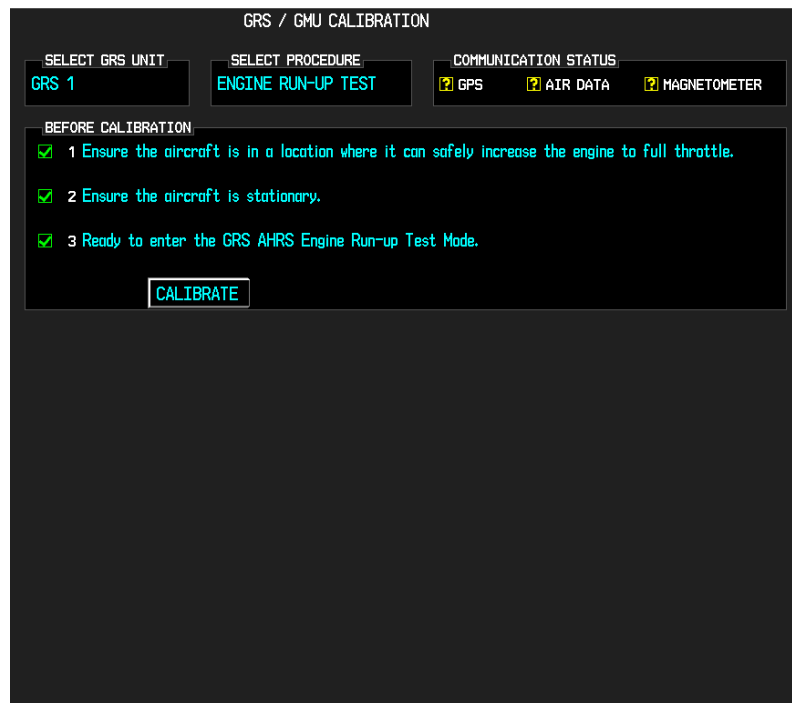

Figure 7-5, GRS/GMU Calibration, Engine Run-Up

1. Restart the PFD in configuration mode.
2. Use the FMS small knob to highlight GRS 1 for calibration and press the ENT key. The SELECT PROCEDURE field is not blinking.
3. Initiate the AHRS engine run-up vibration test procedure by performing the following steps:
  - a) Select the ENGINE RUN-UP TEST procedure and press the ENT key.
  - b) Follow the checklist items displayed on the PFD, and press the ENT key as each one is completed or confirmed. When the CALIBRATE field is blinking, press the ENT key to begin the procedure.
4. The PFD display instructs the operator to gradually increase power from idle to full throttle and back to idle over a period of 1-2 minutes.
5. When the operator has completed the engine run-up and the engine is back to an idle setting, press the ENT key to indicate that the process is complete. When this is done, the TEST COMPLETE field stops blinking.

- 
6. The PFD informs the operator if the installation has passed or failed the vibration test. If the test fails, the specific measurements causing the failure are identified and associated numeric values are displayed on the PFD.

**NOTE**

Should a failure occur, the technician may perform the Engine Run-up test up to 3 times successively before corrective action must be taken. If the test does not pass after three attempts, then the installation should not be considered reliable until the source of the vibration problem is identified and remedied. In the event of repeated failure of the engine run-up test, record the values that are reported to be out of range for future reference.

The following are potential causes for failure of the engine run-up test:

- a) Vibration motion of GSU and/or GMU44 caused by neighboring equipment and/or supports.
  - b) Mounting screws and other hardware for GSU and/or GMU44 not firmly attached.
  - c) GSU/GRS connector not firmly attached to unit.
  - d) Cabling leading to GSU or GMU44 not firmly secured to supporting structure.
  - e) An engine / propeller that is significantly out of balance.
7. Press the ENT key on the PFD to conclude this procedure, then the aircraft can be taxied back and the engine can be shut down for final testing. Continue to Section 7.4.5.

---

## 8. Subsystem Functional Checks

### 8.1 FliteCharts Functional Check

FliteCharts is enabled by default.

1. If Dual Charts are installed, ensure FlightCharts are set as the preferred charts.
2. With the G1000 in Normal Mode, use the MFD FMS knob to select **Aux – System Status** page, then select MFD1 DB softkey.
3. Use the small FMS knob to scroll to CHART.
4. Verify “FliteCharts” is displayed in blue text adjacent to “CHART”.
5. Verify the FliteCharts database cycle number is displayed in blue text and the FliteCharts database is current.
6. Deactivate the cursor and use the MFD large FMS knob to select the **Map - Navigation Map** page then press the Charts softkey.
7. Verify the airport chart is displayed and the following softkeys are displayed (some softkeys may be grayed out):
  - CHRT OPT
  - Show Map
  - INFO-1
  - DP
  - STAR
  - APR
  - WX
  - NOTAM
  - Go Back
8. Press the CHRT OPT softkey and verify the following softkeys are displayed (some softkeys may be grayed out):
  - All
  - Header
  - Plan
  - Profile
  - Minimums
  - Fit WDTH
  - Full SCN
  - Back
9. If no other service is to be performed, continue to the return-to-service checks in Section 9.

---

## 8.2 ChartView Functional Check

ChartView must be enabled using a ChartView Enable Card. Reference Section 3.8.1 for enabling procedures.

### NOTE

The required ChartView databases are subscription-based and are to be procured by the aircraft owner directly from Jeppesen.

1. Ensure ChartView are set as the preferred charts.
2. With the G1000 in Normal Mode, use the MFD FMS knob to select '**Aux – System Status**' page, then select MFD1 DB softkey.
3. Use the small FMS knob to scroll to CHART.
4. Verify "ChartView" is displayed in blue text adjacent to CHART.
5. Verify the ChartView database cycle number is displayed in blue text and the ChartView database is current.
6. Deactivate the cursor and use the large MFD FMS knob to select the Navigation Map Page then press the Charts softkey.
7. Verify the airport chart is displayed and the following softkeys are displayed (some softkeys may be grayed out):
  - CHRT OPT
  - Show Map
  - INFO-1
  - DP
  - STAR
  - APR
  - WX
  - NOTAM
  - Go Back
8. Press CHRT OPT softkey and verify the following softkeys are displayed (some softkeys may be grayed out):
  - All
  - Header
  - Plan
  - Profile
  - Minimums
  - Fit WDTH
  - Full SCN
  - Back
9. If no other service is to be performed, continue to the return-to-service checks in Section 9.

---

### 8.3 SafeTaxi Functional Check

The maximum map ranges for enhanced detail are configurable by the flight crew. When zoomed in close enough to show the airport detail, the map reveals runways with numbers, taxiways with identifying letters/numbers, and airport landmarks including ramps, buildings, control towers, and other prominent features. Resolution is greater at lower map ranges. When the aircraft location is within the screen boundary, including within SafeTaxi ranges, an airplane symbol is shown on any of the navigation map views for enhanced position awareness.

Any map page that displays the navigation view can also show the SafeTaxi airport layout, within the maximum configured range. The following is a list of pages where the SafeTaxi feature can be seen:

- Navigation Map Page
- Inset map
- HSI map
- Weather Datalink Page
- Airport Information Page
- Intersection Information Page
- NDB Information Page
- VOR Information Page
- User Waypoint Information Page
- Trip Planning Page
- Nearest Pages

1. Use the FMS knob on the MFD to select **Map - Navigation Map** page.
2. On the MFD, press MENU. With Map Settings highlighted, press ENT on the MFD. Rotate the small MFD FMS knob to select the Aviation group and press the ENT key on MFD.
3. Turn the MFD large FMS Knob to scroll through the Aviation Group options to 'SafeTaxi'.
4. Turn the MFD small FMS Knob to display the range of distances.
5. Turn the MFD FMS Knob to select 1.5nm as the distance for maximum SafeTaxi display range, and then press the MFD ENT key to complete the selection.
6. Using the MFD range knob, select a range of 1.5nm or less. Verify SafeTaxi display represents the current aircraft location and the airport layout.
7. If no other service is to be performed, continue to the return-to-service checks in Section 9.

## 9. G1000 System Return to Service Procedure

If a G1000 LRU was replaced, verify the correct LRU software part numbers and versions against the numbers listed on the General Arrangement drawing listed in Table 1-1.

Perform the following subsection tests to confirm the G1000 system is operating correctly.

### 9.1 Display Test

1. Apply aircraft power. On the MFD power-up screen in the upper right corner, find the 'Cessna XXX System XXXX.XX' number, where XXX is the airframe type and XXXX-XX is the number of the G1000 System Software Loader Image version number that was used to install the software to the system. (182T image shown for reference, others are similar)

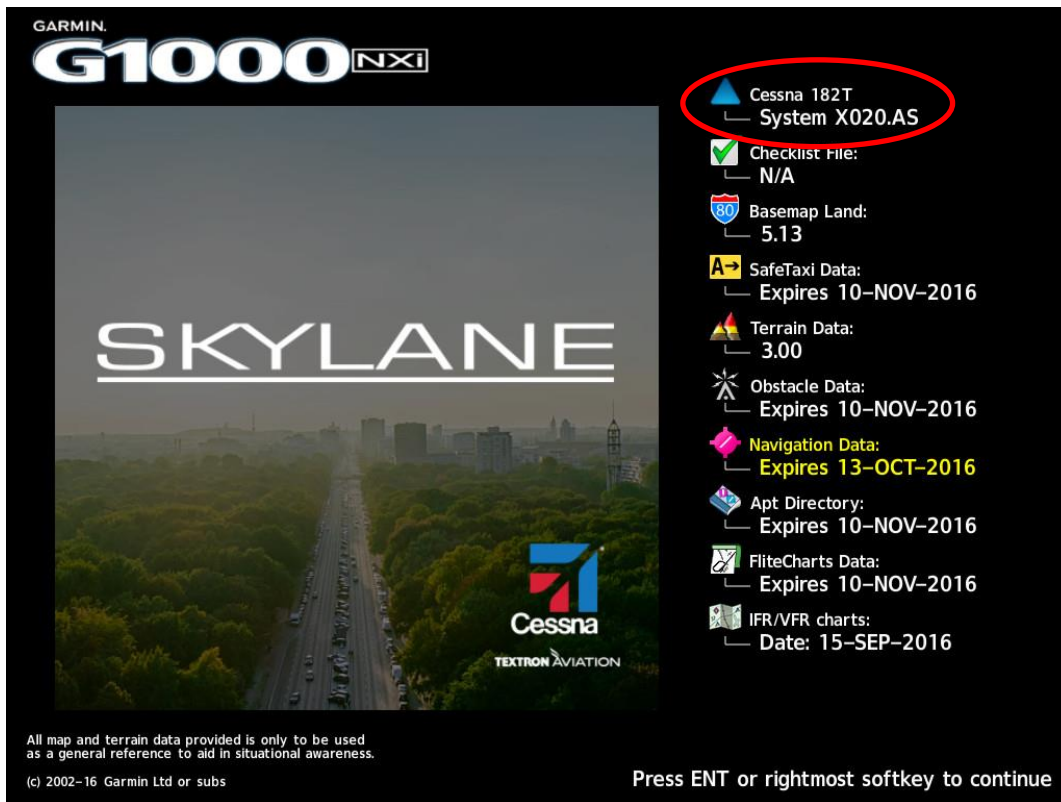
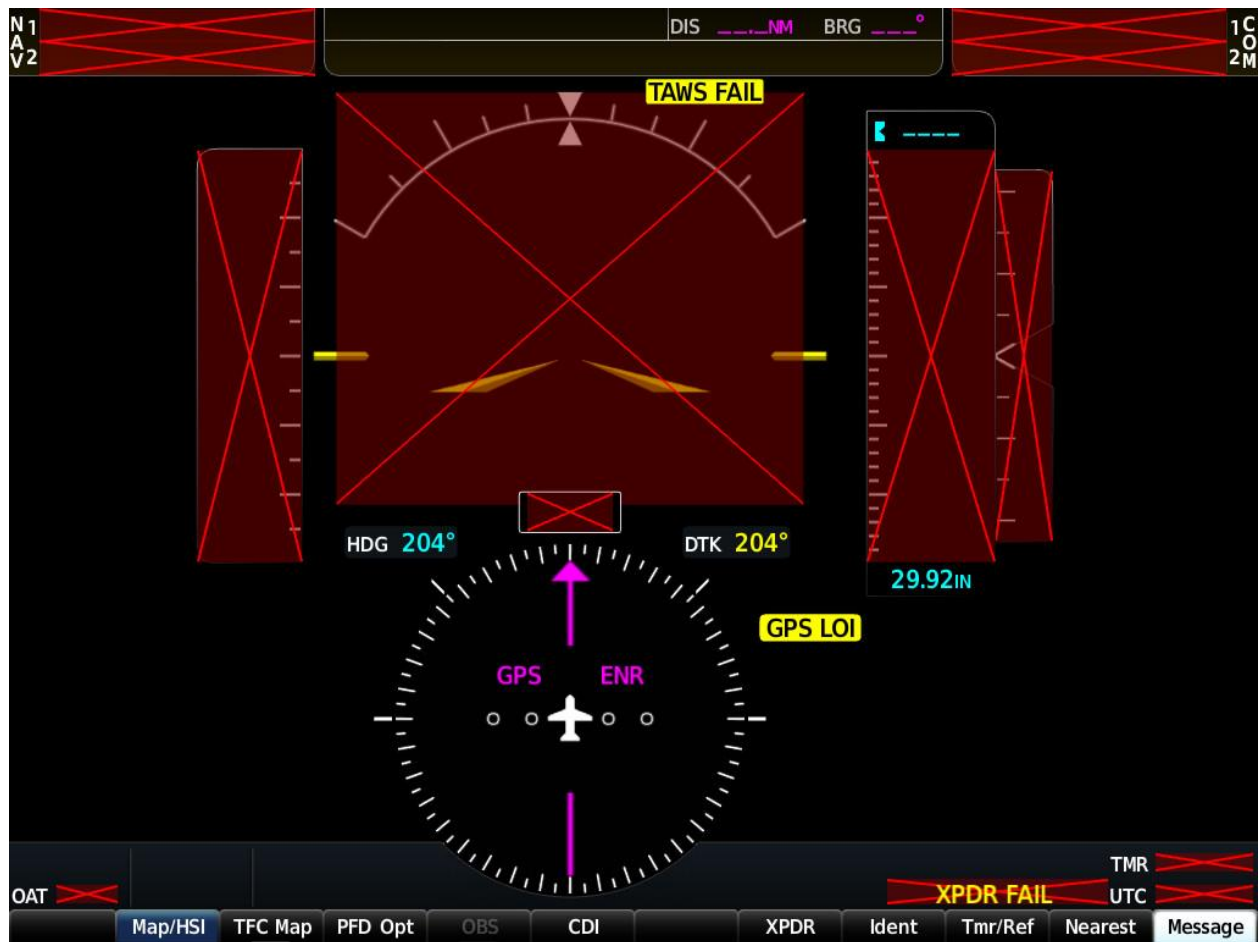

Figure 9-1, MFD Power Up Page

2. Verify that the System Software Version is the same as listed in Table 1 of the 005-01474-01 General Arrangement Drawing.
3. Press the MFD **ENT** key to acknowledge the 'DEFAULT PROFILE' Crew Profile option on the MFD (NOTE: The rightmost softkey may also be used).



**Figure 9-2, PFD Power-up System Annunciations**

4. Allow the displays to initialize for approximately one minute. During normal operation, this causes the airspeed, altitude, vertical speed, and OAT fields to be invalid during the first ~40-60 seconds of PFD power-up. After two minutes, verify no Red-X's are present on the PFD and the MFD. Examples of potential Red-Xs are shown in Figure 9-2. If any Red-X's are present, stop and troubleshoot per Section 5. Examples of a PFD with no Red-X failure indications are shown in Figure 9-3.



(Without SVS enabled)



(With SVS enabled)

Figure 9-3, PFD Normal Operation

---

## **NOTE**

Outputs from the GRS 77 and GMU 44 or GSU 75 are not valid until the units have been calibrated. Refer to the Cessna G1000 NAV III Line Maintenance Manual for calibration procedures.

5. Check that all COM/NAV fields are valid in the top corners of the PFD.
6. Check that altitude, airspeed, vertical speed, GS, TAS, and OAT fields are valid on PFD.
7. Press the PFD Opt softkey on each PFD.
8. Check that engine instrument fields are valid on the MFD.
9. Verify that no MANIFEST alert messages appear in the lower right corner (press the flashing **ALERTS** softkey to view alert messages). If any MANIFEST errors appear, the correct software to the related LRU must be loaded before proceeding.

### **9.2 Display Failure Test**

<b>Step</b>	<b>Desired Result</b>
MFD Failure Condition: <ul style="list-style-type: none"><li>• Open MFD CB.</li><li>• Verify desired results.</li><li>• Close MFD CB.</li></ul>	For an MFD failure condition, the following shall occur: <ol style="list-style-type: none"><li>1. MFD goes blank.</li><li>2. All PFD primary flight information is retained.</li><li>3. The COM 1 and NAV 1 tuning fields remain valid and can be tuned by rotating the tuning knobs on PFD.</li><li>4. XPDR fields remain valid and XPDR can adjusted via PFD softkeys.</li></ol>
PFD Display Failure Condition: <ul style="list-style-type: none"><li>• Open PFD ESS BUS and PFD AVN BUS 1 circuit breakers.</li><li>• Verify desired results.</li><li>• Close PFD ESS BUS and PFD AVN BUS 1 circuit breakers.</li></ul>	For a PFD failure condition, the following shall occur: <ul style="list-style-type: none"><li>• PFD goes blank.</li><li>• MFD switches automatically to reversionary mode</li></ul>

### 9.3 Reversion Mode Check

6. Push the red **DISPLAY BACKUP** button on the GMA. Verify that the PFD and MFD displays enter reversion mode (See Figure 9-4). MFD should have valid altitude, airspeed, vertical speed, COM1, COM2, NAV1, NAV2 and engine instruments.



Figure 9-4, GDU Reversionary Mode

7. De-activate reversion mode by pushing the **DISPLAY BACKUP** button. Verify PFD and MFD return to normal display modes.

## 9.4 GPS Signal Acquisition

This test requires the aircraft to be outside to see the GPS satellites or indoors with a GPS repeater.



Figure 9-5, AUX-GPS Status Page

Select the AUX - GPS Status page on the MFD. After the G1000 system has been on for a minimum of two minutes, toggle between GPS 1 and GPS 2 using the two softkeys on the bottom of the display. Verify that both receivers show a 3D GPS Solution in the GPS Status field.

## 9.5 GPS Failure Test

Before starting this test, create a simple Direct-To flight plan to an airport or other waypoint that is greater than 31 NM from the present aircraft position. Verify that the phase of flight displayed on the GPS CDI is ENR.

Step	Desired Result
<p>Single GPS Failure Condition:</p> <ol style="list-style-type: none"> <li>1. Ensure GPS satellites are acquired.</li> <li>2. Place a shroud over the GPS antenna for GIA 1 to prevent signal reception. Verify loss of signal on MFD <b>Aux – GPS Status</b> page.</li> <li>3. Check for desired results.</li> <li>4. Remove shroud from the GIA 1 GPS antenna and allow system to re-acquire satellites.</li> <li>5. Place a shroud over the GPS antenna for GIA 2 to prevent signal reception. Verify loss of signal on MFD <b>Aux – GPS Status</b> page.</li> <li>6. Check for desired results.</li> <li>7. Remove shroud from the GIA 2 GPS antenna.</li> </ol>	<p>For each of the single GPS failure conditions, the following shall remain valid on the PFD throughout the procedure:</p> <ul style="list-style-type: none"> <li>○ Attitude and Heading from AHRS.</li> <li>○ Airspeed, Altitude, Vertical Speed, and OAT from Air Data Computer.</li> <li>○ GPS Course Deviation Indicator</li> </ul>
<p>Dual GPS Failure Condition:</p> <ul style="list-style-type: none"> <li>• Ensure GPS satellites are acquired.</li> <li>• Cover both GPS antennas. Verify loss of signal on <b>Aux – GPS Status</b> page.</li> <li>• Check for desired results.</li> <li>• Remove shrouds from GPS antennas.</li> <li>• Allow both receivers to re-acquire satellite signals before continuing.</li> </ul>	<p>For a dual GPS failure condition, the following shall occur:</p> <ul style="list-style-type: none"> <li>• GPS CDI flags LOI on the PFD.</li> <li>• Attitude and Heading remain valid from both AHRS on the PFD.</li> <li>• Airspeed, Altitude, Vertical Speed and OAT remain valid from both Air Data Computers on the PFD.</li> <li>• LOI appears on MFD Map.</li> <li>• TAWS N/A aural alert &amp; annunciation given.</li> </ul> <p>When GPS satellites are re-acquired, verify that the INTEG OK annunciation is given on the HSI in white for a brief period of time then disappears.</p> <p>After ~10 seconds of stable GPS position reacquisition, verify the TAWS AVAILABLE aural alert is given.</p> <p>Verify that the system returns to normal navigation mode (GPS CDI restored, LOI annunciation removed, &amp; GPS data magenta).</p>

---

## 9.6 G1000 Backup Path Test

With both displays in normal mode and the entire avionics system turned on, verify on PFD there is not a system alert message stating "Failed Data Path". If this message is present, troubleshoot per Section 5.1.1 and resolve the issue before continuing.

## 9.7 Maintenance Records

Record the following information:

- Part number of the G1000 software loader card used to perform software loading or software updates.
- Record part and serial numbers of any LRU which was replaced.
- Record any database updates which were performed during maintenance.
- Any other applicable information related to the maintenance work performed on the aircraft.

---

## APPENDIX A - Garmin Unit Part and Serial Number Cross Reference

This table allows shows the unit part number and serial number prefix combinations.

<b>LRU</b>	<b>PART NUMBER</b>	<b>SERIAL NUMBER FIRST THREE DIGITS</b>
GDU 1054B (PFD & MFD)	011-03470-70	494
GDU 1050 (PFD & MFD) (ONLY ON 172 WITHOUT AUTOPILOT)	011-03470-00	494
GSU 75 (OPTIONAL)	011-03094-00	3KY
GTX 335R (OPTIONAL)	011-03301-00	3EF
GTX 345R (OPTIONAL)	011-03303-00	3EH
GDL 69 SXM (OPTIONAL)	011-03177-10	3NV
FLIGHT STREAM 510 (OPTIONAL)	011-03595-00	402