

GARMIN[®]

GC™ 100

INSTALLATION INSTRUCTIONS

Getting Started

⚠ WARNING

See the *Important Safety and Product Information* guide in the product box for product warnings and other important information.

Mounting Considerations

- You must mount the camera in a location where it is not submerged.
- You should mount the camera within 76 m (250 ft.) of a chartplotter. The range depends on your installation location and obstacles between the camera and the chartplotter. If the camera is out of range of the chartplotter due to obstacles or distance, you must reposition the camera.
- You should test the camera in your desired location before you permanently mount the camera.
- You should mount the camera so that the cable can be connected easily.
- You should mount the camera in a location where it cannot be damaged by docks, pilings, or other pieces of equipment.
- You should mount the camera so it does not present a hazard in doorways or walkways.
- You should mount the camera in a location where you can remove the camera.

Mounting the Camera

- 1 Using a 3.2 mm (1/8 in.) drill bit, drill a pilot hole.

NOTE: If you are mounting the camera onto fiberglass, it is recommended to use a countersink bit to drill a clearance counterbore through the top gelcoat layer only, but no deeper. This will help to avoid cracking the gelcoat layer when the screws are tightened.

- 2 Using the included screw, fasten the camera mount to the mounting surface.
- 3 Insert the camera ① into the housing ②.

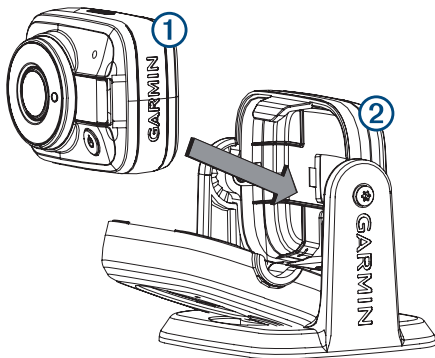

- 4 Close the front of the housing.

- 5 Tighten the tamper-proof side screws using the included tool.
- 6 Connect the power cable.

Connecting to Power

⚠ WARNING

When connecting the power cable, do not remove the in-line fuse holder. To prevent the possibility of injury or product damage caused by fire or overheating, the appropriate fuse must be in place as indicated in the product specifications. In addition, connecting the power cable without the appropriate fuse in place voids the product warranty.

- 1 Route the power cable to the power source and to the device.
- 2 Connect the red wire to the positive (+) battery terminal, and connect the black wire to the negative (-) battery terminal.

Pairing the GC 100 Camera with a Garmin® Chartplotter

Before you can connect a wireless device to the chartplotter wireless network, you must configure the chartplotter wireless network. See your chartplotter manual for information on configuring the wireless network.

- 1 With the camera within an unobstructed 76 m (250 ft.) of the chartplotter, quickly press three times.
- 2 On the chartplotter, select **Settings > Communications > Wireless Devices > Garmin Camera > Start**.
- 3 Follow the on-screen instructions.

Turning the Camera Off

Hold for 3 seconds.

NOTE: If you hold for more than 10 seconds, the camera resets.

Specifications

Water rating	IEC 60529 IPX6/IPX7 ¹
Operating temperature range	From -20 to 60°C (from -4 to 140°F)
Charging temperature range	From 0 to 45°C (from 32 to 113°F)
Storage temperature range	From -40 to 85°C (from -40 to 185°F)
Input voltage	From 10 to 30 Vdc, 1.5 A max.
Compass-safe distance	10 cm (4 in.)
Wireless frequency and protocol	2.4 GHz @ 17 dBm nominal

GC 100 Blink Codes

After the camera is installed and paired with the chartplotter, the camera turns on when the chartplotter is turned on. The color and blink sequence of the status LED on the camera indicates its operational status.

LED Color	LED State	Status
Green	Three blinks	The camera is turning on.
Red	Three blinks	The camera is turning off.

¹ The device withstands incidental exposure to water of up to 1 m for up to 30 min. For more information, go to www.garmin.com/waterrating.

TRA
REGISTERED No:
ER62993/18
DEALER No:
DA0015955/08



LED Color	LED State	Status
Blue	One blink per second for up to two minutes, or until the camera connects to a chartplotter	The camera is attempting to connect to a chartplotter using Wi-Fi®.
Amber	One blink per second until the camera powers down or the battery is charged	The camera battery is not charged sufficiently to stream video.

© 2018 Garmin Ltd. or its subsidiaries

Garmin® and the Garmin logo are trademarks of Garmin Ltd. or its subsidiaries, registered in the USA and other countries. GC™ is a trademark of Garmin Ltd. or its subsidiaries. These trademarks may not be used without the express permission of Garmin.

Wi-Fi® is a registered mark of Wi-Fi Alliance Corporation.