

# GARMIN®

## GPS 24XD NMEA 2000®

---

### INSTALLATION INSTRUCTIONS

#### Important Safety Information

#### CAUTION

To avoid possible personal injury, always wear safety goggles, ear protection, and a dust mask when drilling, cutting, or sanding.

#### NOTICE

When drilling or cutting, always check what is on the opposite side of the surface to avoid damaging the vessel.

For the best performance and to avoid damage to your boat, read all installation instructions before proceeding. Install the device per these instructions. Use the appropriate fasteners, tools, and mounts listed, which are available at most marine dealers.

The Garmin® GPS 24xd NMEA 2000 high-sensitivity GPS antenna provides position information to your existing NMEA 2000 network. If your boat does not have a NMEA 2000 network, you will need to install one.

For more information, go to [garmin.com](https://www.garmin.com).

#### Tools Needed

- Drill
- 3.2 mm (1/8 in.) drill bit
- 19 mm (3/4 in.) drill bit for a pole-mount cable-hole
- 25 mm (1 in.) hole saw for a surface-mount cable-hole
- Countersink bit for mounting on fiberglass
- Screws for under-deck mounting
- Screwdriver, appropriate for the screw type
- Marine sealant (optional)
- Additional NMEA 2000 network components as needed



# Mounting the Antenna

## Antenna Mounting Considerations

### ⚠ CAUTION

Do not install or store the antenna near strong magnets, including speakers. A strong magnetic field can damage the antenna.

You can mount the antenna on a flat surface or attach it to a standard 1 in. OD, 14 threads per inch, pipe-threaded pole (not included). You can route the cable outside of the pole or through the pole. For best performance, consider these guidelines when selecting the antenna mounting location.

- To ensure the best reception, the antenna should be mounted in a location that has a clear, unobstructed view of the sky in all directions ①.

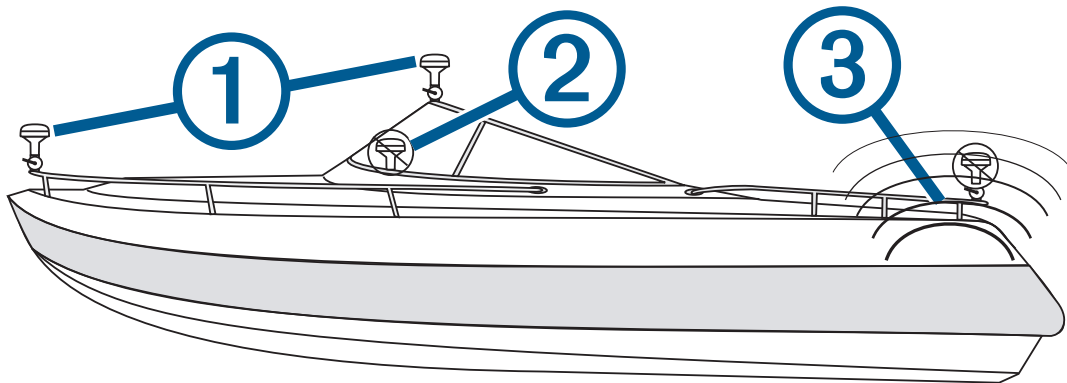

- The antenna should not be mounted where it is shaded by the superstructure of the boat ②, a radome antenna, or the mast.
- The antenna should not be mounted near the engine or other sources of Electromagnetic Interference (EMI) ③.
- The antenna should not be mounted near known ferrous metal objects such as a toolbox or compass.
- A handheld compass should be used to test for magnetic interference in the area where the antenna is to be mounted. Your boat, motors, and devices must be on during the test.  
If the needle on the handheld compass moves when you hold it where you intend to mount the antenna, magnetic interference is present. You must choose another location and test again.
- Mounting screws are provided with the antenna. If you use mounting hardware other than the provided screws, the hardware must be made of quality stainless steel or brass material to avoid magnetic interference with the antenna.  
**NOTE:** Test all mounting hardware with a handheld compass to make sure no magnetic fields are present in the hardware.
- If a radar is present, the antenna should be mounted above the path of the radar ④. If necessary, the antenna may be mounted below the path of the radar ⑤.

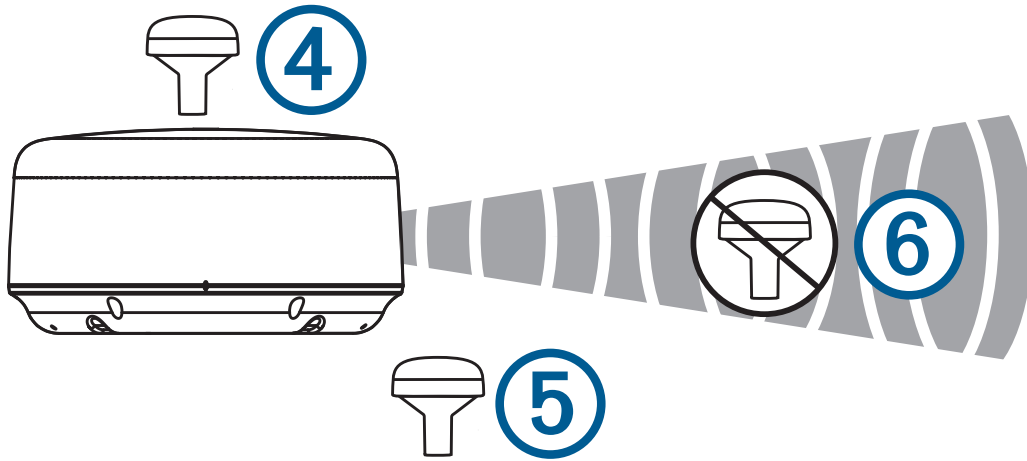

- The antenna should not be mounted directly in the path of the radar ⑥.
- The antenna should not be mounted within 1 m (3 ft.) of a VHF radio antenna or the path of a radar ⑦.

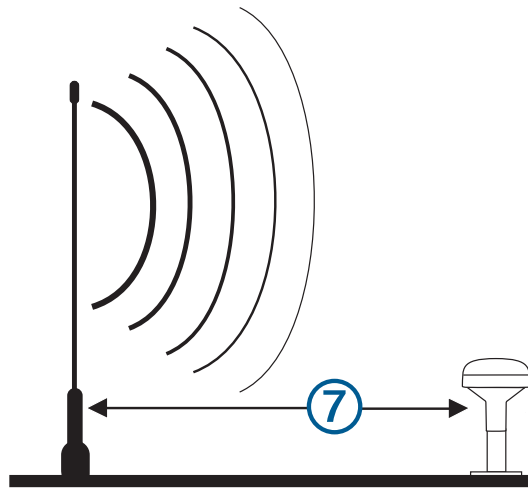

### Testing the Mounting Location

- 1 Temporarily secure the antenna in the preferred mounting location and test it for correct operation.
- 2 If you experience interference with other electronics, move the antenna to a different location, and test it again.
- 3 Repeat steps 1–2 until you observe full or acceptable signal strength.
- 4 Permanently mount the antenna.

## Surface Mounting the Antenna

### NOTICE

If you are mounting the bracket on fiberglass with screws, it is recommended to use a countersink bit to drill a clearance counterbore through only the top gel-coat layer. This will help to avoid cracking in the gel-coat layer when the screws are tightened.

Before you permanently mount the antenna, you must test the mounting location for correct operation (*Testing the Mounting Location*, page 3).

- 1 Using the surface-mount bracket ① as your mounting template, mark the three pilot-hole locations and trace the cable-hole in the center of the bracket.

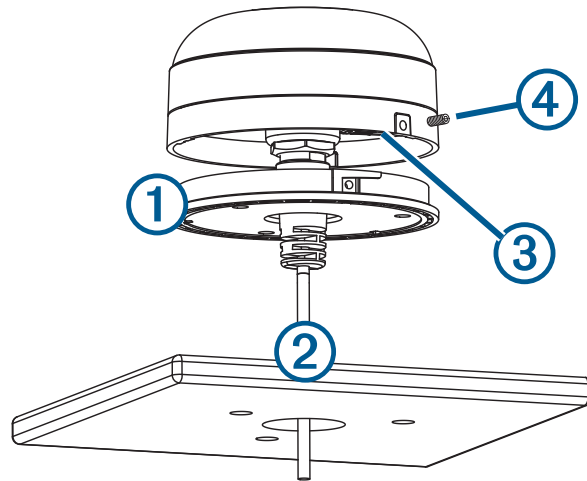

- 2 Set the surface-mount bracket aside.  
Do not drill through the bracket.
- 3 Use a 3.2 mm ( $\frac{1}{8}$  in.) drill bit to drill the three pilot holes.
- 4 Use a 25 mm (1 in.) drill bit or hole saw to drill or cut the cable hole in the center.
- 5 Use the included M4 screws and a Phillips screwdriver to secure the surface-mount bracket to the mounting surface.  
If the included M4 screws are too short, use M4 screws of appropriate length.
- 6 Route the cable ② through the center hole, and connect it to the antenna.
- 7 Verify the large gasket ③ is in place on the bottom of the antenna, place the antenna on the surface-mount bracket, and twist it clockwise to lock it in place.
- 8 Use the M3 set screw and a 1.5 mm hex wrench to secure the antenna to the mounting bracket ④.
- 9 Route the cable away from sources of electronic interference.

## Mounting the Antenna on a Pole

### Mounting the Antenna with the Cable Routed Outside the Pole

Before you permanently mount the antenna, you must test the mounting location for correct operation (*Testing the Mounting Location*, page 3).

- 1 Route the cable through the pole-mount adapter ①, and place the cable in the vertical slot ② along the base of the pole-mount adapter.

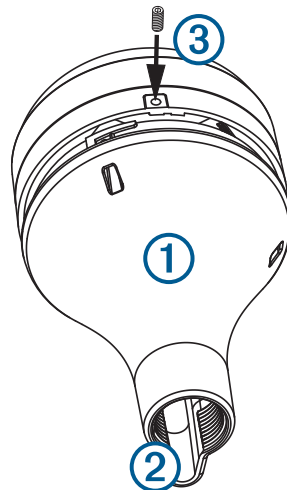

- 2 Screw the pole-mount adapter onto a standard 1 in. OD, 14 threads per inch, pipe-threaded pole (not included).  
Do not overtighten the adapter on the pole.
- 3 Connect the cable to the antenna.
- 4 Place the antenna on the pole-mount adapter and twist it clockwise to lock it in place.
- 5 Use the included M3 set screw and a 1.5 mm hex wrench to secure the antenna to the adapter ③.
- 6 With the antenna installed on the pole mount, fill the remaining gap in the vertical cable slot with a marine sealant (optional).
- 7 Attach the pole to the boat if it is not already attached.
- 8 Route the cable away from sources of electronic interference.

### Mounting the Antenna with the Cable Routed Through the Pole

Before you permanently mount the antenna, you must test the mounting location for correct operation (*Testing the Mounting Location*, page 3).

- 1 Position a standard 1 in. OD, 14 threads per inch, pipe-threaded pole (not included) in the selected location, and mark the approximate center of the pole.
- 2 Use a 19 mm ( $3/4$  in.) drill bit to drill a hole for the cable to pass through.
- 3 Fasten the pole to the boat.
- 4 Thread the pole-mount adapter onto the pole.  
Do not overtighten the adapter.
- 5 Route the cable through the pole and connect it to the antenna.
- 6 Place the antenna on the pole-mount adapter and twist it clockwise to lock it in place.

- 7 Use the included M3 set screw and a 1.5 mm hex wrench to secure the antenna to the adapter ①.

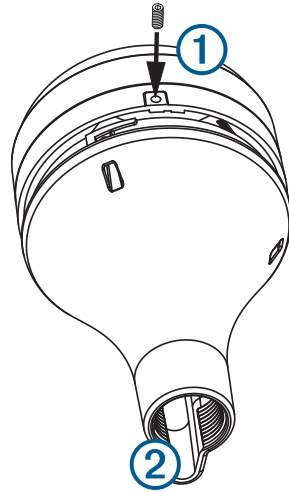

- 8 With the antenna installed on the pole mount, fill the vertical cable slot ② with a marine sealant (optional).  
9 Route the cable away from sources of electronic interference.

## Mounting the Antenna Under the Deck

### NOTICE

Before using the included screws to secure the under-deck mounting bracket, verify they are short enough to avoid penetrating through the surface. If necessary, purchase screws of the appropriate length.

Before you permanently mount the antenna, you must test the mounting location for correct operation (*Testing the Mounting Location, page 3*).

Because the antenna cannot acquire signals through metal, it must be mounted under a fiberglass surface only. The under-deck mounting kit is supplied with the white antenna models only.

- 1 Place the adhesive pads ① on the under-deck mounting bracket ②.

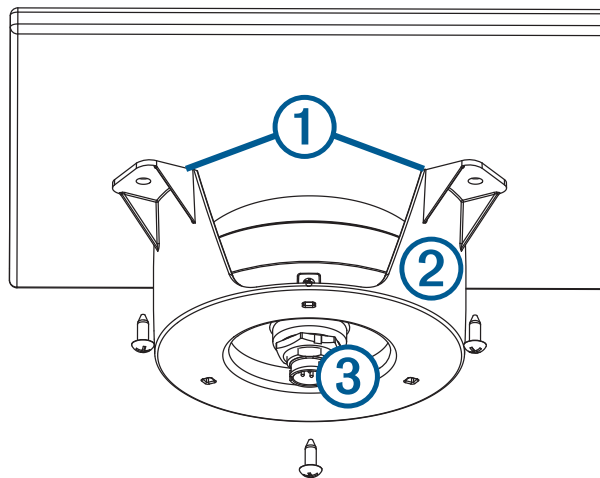

- 2 Place the antenna in the under-deck mounting bracket.  
3 Adhere the under-deck mounting bracket to the mounting surface.  
4 Secure the under-deck mounting bracket to the mounting surface with screws.  
5 Connect the cable to the antenna ③.  
6 Route the cable away from sources of electronic interference.

## Connecting the Antenna

### NMEA 2000 Network Connection

If you do not have an existing NMEA 2000 network, you must install a NMEA 2000 network on your boat. For more information on NMEA 2000, go to [garmin.com/manuals/nmea\\_2000](http://garmin.com/manuals/nmea_2000).

The antenna is packaged with a NMEA 2000 T-connector and a NMEA 2000 drop cable. You will use these two components to connect the antenna to your existing NMEA 2000 network.

A 6 m (20 ft.) drop cable is included. If more cable is needed, add an extension to your NMEA 2000 backbone, based on the NMEA 2000 guidelines. A shorter drop cable can be installed if desired.

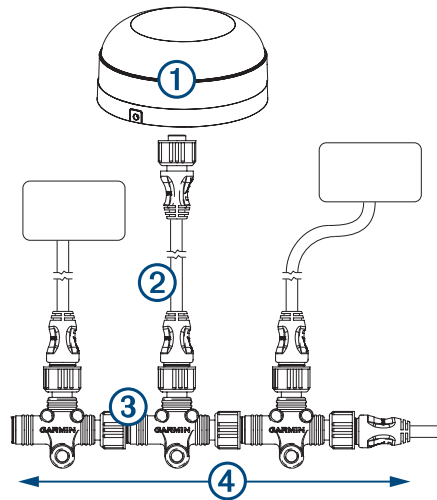

①	GPS 24xd antenna
②	NMEA 2000 drop cable
③	NMEA 2000 T-connector
④	NMEA 2000 backbone

### Heading Calibration

After installation is complete, you must calibrate the heading and perform the auto heading alignment to receive magnetic heading data.

Depending on the types of devices connected to the NMEA 2000 network, you can calibrate the antenna using either a menu-based method or a basic method.

If you connect the antenna to a NMEA 2000 network with a compatible Garmin chartplotter, you can perform either the basic calibration or the menu-based calibration (*Performing Menu-Based Calibration, page 8*).

If you connect the antenna to a NMEA 2000 network without a compatible Garmin chartplotter or with a third-party device, you must perform basic calibration instead of menu-based calibration.

## Performing Menu-Based Calibration

Before you can perform menu-based calibration, you must connect the antenna to the same NMEA 2000 network as a compatible Garmin chartplotter.

- 1 Select **Menu > Settings > Communications > NMEA 2000 Setup > Device List**.
- 2 Select the GPS 24xd NMEA 2000 from the device list.
- 3 Select **Review > Compass Cal. > Begin**.
- 4 Follow the on-screen instructions until the compass calibration is complete, taking care to keep the boat as steady and level as possible.

The boat should not list during calibration.

When the compass calibration is complete, a value appears near the Compass Cal. setting. A value near 100 indicates the antenna was installed in a perfect magnetic environment and calibrated correctly. If the heading performance is unacceptable, and the value is closer to 0 than it is to 100, you might need to relocate the antenna and calibrate the compass again.

**NOTE:** The antenna compass must be calibrated successfully and maintain a valid GPS position, which requires the antenna to have a clear, unobstructed view of the sky in all directions, before you proceed to Auto Heading Alignment.

- 5 Select **Auto Heading Alignment**.
- 6 Select **Begin**.
- 7 Follow the on-screen instructions until the magnetic heading alignment is complete.

## Disabling the Magnetic Heading Data

If you cannot mount the antenna in an ideal location for magnetic heading and GPS performance, you can disable the magnetic heading data.

Perform a factory reset ([Antenna Configuration, page 11](#)).

The device still outputs GPS Course over Ground.

## Adjusting the Fine Heading Alignment

You can adjust the Fine Heading Alignment in conjunction with Auto Heading Alignment to fine-tune the heading output (optional).

**NOTE:** Fine heading alignment must be completed under open skies to ensure proper calibration.

- 1 Select **Settings > Communications > NMEA 2000 Setup > Device List**.
- 2 Select the GPS 24xd device.
- 3 Select **Review > Fine Heading Alignment**.
- 4 Using a landmark or a known good compass, determine the heading of your boat.
- 5 Adjust the heading until it matches your measurement.
- 6 Select **Done**.



## Performing Basic Calibration

If you connect the antenna to a NMEA 2000 network without a compatible Garmin chartplotter or with a third-party device, you must perform basic calibration instead of menu-based calibration.

Before you can perform basic calibration, you must be able to view heading data from the NMEA 2000 network on a connected device. To perform basic calibration, you must remove from the network all sources of heading data other than the antenna.

When performing basic calibration, you first calibrate the compass and then align the heading in one continuous procedure.

**NOTE:** The boat must be able to reach a cruising speed of at least 6.4 km/h (4 mph) to perform the heading alignment.

- 1 Drive the boat to a location with calm, open water.
- 2 Set the display to view heading data from the connected antenna.  
**NOTE:** You must not use GPS Course Over Ground (COG) to perform basic calibration.
- 3 Disconnect the antenna from the NMEA 2000 network or turn off the power to the NMEA 2000 network.
- 4 Wait while the boat becomes level and stationary.
- 5 Turn on power to the antenna, and wait until the heading data appears on the display ①.

**NOTE:** If you are performing the first basic calibration after a factory reset, the heading is blank.

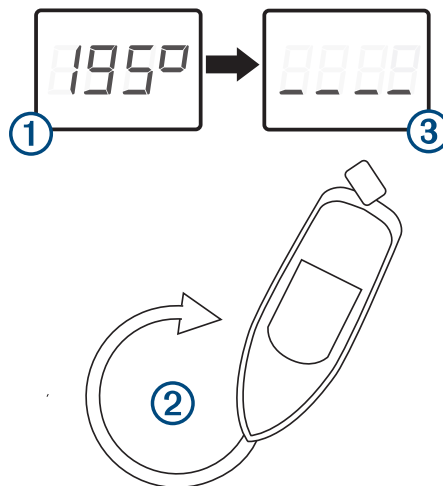

- 6 Within three minutes, complete two full, slow, tight circles ②, taking care to keep the boat as steady and level as possible.

The boat should not list during calibration.

When the antenna is prepared to calibrate the compass, the heading data disappears from the display ③.

You may receive an error message that the heading was lost. You can ignore this message.

- 7 Continue turning in the same direction at the same speed ④ for approximately 1 1/2 rotations until the heading data appears ⑤.

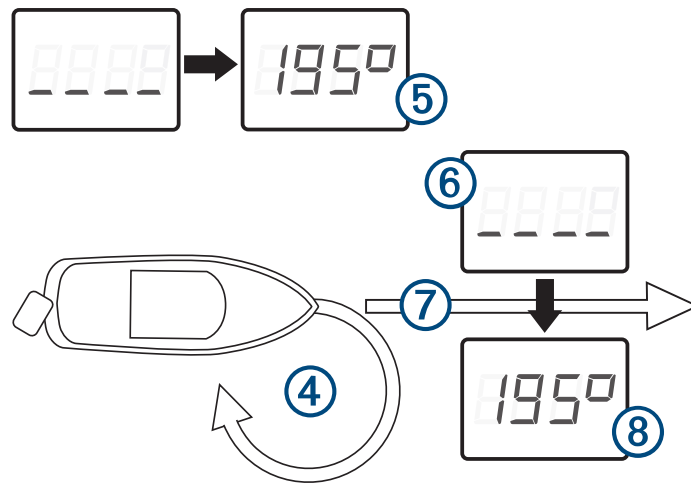

When the heading data appears, the compass has been calibrated successfully, and you can align the heading (optional).

- 8 Select an option.
- If you want to align the heading to match the front of the boat, proceed to the next step.
  - If you do not want to align the heading, stop turning and wait, keeping the boat stationary. Over the next two minutes the heading data should disappear and then reappear. When the heading data reappears, the compass should be calibrated and no heading offset should be applied.
- 9 Continue turning in the same direction at the same speed for approximately ten seconds, until the heading data disappears from the display ⑥.
- 10 When it is safe, straighten the boat and drive in a straight line ⑦ at cruising speed (must be at least 6.4 km/h (4 mph)) until the heading data appears ⑧.
- When the heading appears, the compass has been calibrated, and the heading has been aligned on the antenna.
- 11 Test the results of the calibration, and repeat this procedure if necessary.

## Disabling the Magnetic Heading Data

If you cannot mount the antenna in an ideal location for magnetic heading and GPS performance, you can disable the magnetic heading data.

- 1 Drive the boat to a location with calm, open water.
- 2 Set the display to view heading data from the antenna.
- 3 Disconnect the antenna from the NMEA 2000 network or turn off the power to the NMEA 2000 network.
- 4 Wait while the boat becomes level and stationary.
- 5 Turn on power to the antenna, and wait until the heading data appears on the display ①.

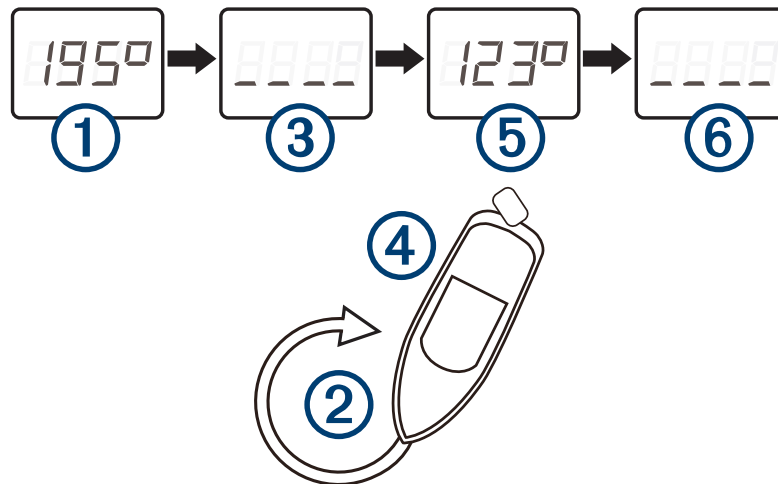

- 6 Within three minutes, complete two full, slow, tight circles ②, taking care to keep the boat as steady and level as possible.  
Heading data disappears to indicate that the antenna has detected the start of the procedure ③.  
You may receive an error message that the heading was lost. You can ignore this message.
- 7 Bring the boat to a complete stop ④, and remain stationary for two minutes.  
After two minutes, the heading data reappears with a fixed value of 123 degrees ⑤ to indicate heading will be disabled on the next power cycle.  
**NOTE:** If the magnetic heading is displayed, the fixed value is 123 degrees. If the true heading is displayed, the fixed value may deviate because of corrections from magnetic variation.
- 8 Disconnect the antenna from the NMEA 2000 network or turn off the power to the NMEA 2000 network.
- 9 Turn on power to the antenna, and verify that heading has been disabled ⑥.

## Antenna Configuration

Your antenna is pre-configured, but you may customize your antenna configuration as needed. From the NMEA 2000 device list, select the GPS 24xd, and select Review.

**Auto Locate:** Allows you to clear existing satellite data and force the antenna to acquire new data. This option is only available when the antenna has no position fix.

**Factory Defaults:** Allows you to reset the antenna settings to the factory default value. You will lose all custom configuration settings.

## Cleaning the Outer Casing

### NOTICE

Avoid chemical cleaners and solvents that can damage plastic components.

- 1 Clean the outer casing of the device using a cloth dampened with a mild detergent solution.
- 2 Wipe the device dry.

## Appendix

### Software Update

You must update the Garmin chartplotter software when you install this device. For instructions on updating the software, see your chartplotter owner's manual at [support.garmin.com](http://support.garmin.com).

### Specifications

Dimensions (diameter x height)	3 <sup>19</sup> / <sub>32</sub> × 1 <sup>15</sup> / <sub>16</sub> in. (91.6 × 49.5 mm)
Weight	201 g (7.1 oz.)
NMEA 2000 drop cable length	19 ft., 8 in. (6 m)
Temperature range	White model: From -30° to 80°C (-22° to 176°F) Black model: From -30° to 65°C (-22° to 149°F)
Case material	Fully gasketed, high-impact plastic alloy
Water rating	IEC 60529 IPX6 and IPX7 <sup>1</sup>
Compass-safe distance	12.7 mm (0.5 in.)
Input voltage	From 9 to 32 Vdc
Max. input current	200 mA @ 12 Vdc
Typical input current	150 mA @ 12 Vdc
NMEA 2000 LEN @ 9 Vdc	3
NMEA 2000 draw	150 mA

<sup>1</sup> The device withstands incidental exposure to water of up to 1 m for up to 30 min, and is protected against powerful jets of water. For more information, go to [www.garmin.com/waterrating](http://www.garmin.com/waterrating).

## NMEA 2000 PGN Information

### Transmit

Sentence	Description
059392	ISO acknowledgment
059904	ISO request
060928	ISO address claim
126208	NMEA® - Request group function
126464	Transmit PGN's group function
126992	System time
126993	Heartbeat
126996	Product information
126998	Configuration information
127250	Vessel heading
127257	Attitude data
127258	Magnetic variation
129025	Position, rapid update
129026	COG and SOG, rapid update
129029	GNSS position data
129539	GNSS DOPs
129540	GNSS sats in view

### Receive

Sentence	Description
059392	ISO acknowledgment
059904	ISO request
060928	ISO address claim
126208	NMEA - Request group function
126993	Heartbeat
126996	Product information

### Declaration of Conformity

Hereby, Garmin declares that this product is in compliance with the Directive 2014/53/EU. The full text of the EU declaration of conformity is available at the following internet address: [garmin.com/compliance](http://garmin.com/compliance).

### UK Declaration of Conformity

Hereby, Garmin declares that this product is in compliance with the relevant statutory requirements. The full text of the declaration of conformity is available at the following internet address: [garmin.com/compliance](http://garmin.com/compliance).

## **Innovation, Science and Economic Development Canada Compliance**

This device contains licence-exempt transmitter(s)/receiver(s) that comply with Innovation, Science and Economic Development Canada's licence-exempt RSS(s). Operation is subject to the following two conditions: (1) this device may not cause interference, and (2) this device must accept any interference, including interference that may cause undesired operation of the device.

## **FCC Compliance**

This device complies with part 15 of the FCC Rules. Operation is subject to the following two conditions: (1) this device may not cause harmful interference, and (2) this device must accept any interference received, including interference that may cause undesired operation.

This equipment has been tested and found to comply with the limits for a Class B digital device, pursuant to part 15 of the FCC rules. These limits are designed to provide reasonable protection against harmful interference in a residential installation. This equipment generates, uses, and can radiate radio frequency energy and may cause harmful interference to radio communications if not installed and used in accordance with the instructions. However, there is no guarantee that interference will not occur in a particular installation. If this equipment does cause harmful interference to radio or television reception, which can be determined by turning the equipment off and on, the user is encouraged to try to correct the interference by one of the following measures:

- Reorient or relocate the receiving antenna.
- Increase the separation between the equipment and the receiver.
- Connect the equipment into an outlet on a circuit different from that to which the receiver is connected.
- Consult the dealer or an experienced radio/TV technician for help.

This product does not contain any user-serviceable parts. Repairs should only be made by an authorized Garmin service center. Unauthorized repairs or modifications could result in permanent damage to the equipment, and void your warranty and your authority to operate this device under Part 15 regulations.

## **Limited Warranty**

The Garmin standard limited warranty applies to this accessory. For more information, go to [garmin.com/support/warranty](https://garmin.com/support/warranty).

**Australian Purchases:** Our goods come with guarantees that cannot be excluded under the Australian Consumer Law. You are entitled to a replacement or refund for a major failure and for compensation for any other reasonably foreseeable loss or damage. You are also entitled to have the goods repaired or replaced if the goods fail to be of acceptable quality and the failure does not amount to a major failure. The benefits under our Limited Warranty are in addition to other rights and remedies under applicable law in relation to the products. Garmin Australasia, 30 Clay Place, Eastern Creek, NSW 2766, Australia. Phone: 1800 235 822.

## 物質宣言

部件名称	有毒有害物质或元素									
	铅	汞	镉	六价铬	多溴联苯	多溴二苯醚	邻苯二甲酸二(2-乙基己)酯	邻苯二甲酸丁苄酯	邻苯二甲酸二丁酯	邻苯二甲酸二异丁酯
印刷电路板组件	×	○	○	○	○	○	○	○	○	○
金属零件	×	○	○	○	○	○	○	○	○	○
电缆 电缆组件 连接器	×	○	○	○	○	○	○	○	○	○
塑料和橡胶零件	○	○	○	○	○	○	○	○	○	○

本表格依据 SJ/T11364 的规定编制。

○: 代表此种部件的所有均质材料中所含的该种有害物质均低于 (GB/T26572) 规定的限量

×: 代表此种部件所用的均质材料中, 至少有一类材料其所含的有害物质高于 (GB/T26572) 规定的限量

\* 该产品说明书应提供在环保使用期限和特殊标记的部分详细讲解产品的担保使用条件。



产品

## 連絡地址

製造銷售:台灣國際航電股份有限公司

聯絡地址:新北市汐止區樟樹二路 68 號

電話:(02)2642-8999

客服專線:(02)2642-9199

© 2020 Garmin Ltd. or its subsidiaries

Garmin® and the Garmin logo are trademarks of Garmin Ltd. or its subsidiaries, registered in the USA and other countries. These trademarks may not be used without the express permission of Garmin.

NMEA 2000® and the NMEA 2000 logo are registered trademarks of the National Marine Electronics Association.

Garmin Corporation

