

# GARMIN®

## REACTOR™ 40 FOR SMARTPUMP INSTALLATION INSTRUCTIONS

### Important Safety Information

#### WARNING

See the *Important Safety and Product Information* guide in the product box for product warnings and other important information.

To avoid possible personal injury and damage to your boat, the autopilot system should be installed by a qualified marine installer. Specific knowledge of marine steering and electrical systems is required for proper installation.

You are responsible for the safe and prudent operation of your vessel. The autopilot is a tool that enhances your capability to operate your boat. It does not relieve you of the responsibility of safely operating your boat. Avoid navigational hazards and never leave the helm unattended.

Always be prepared to promptly regain manual control of your boat.

Learn to operate the autopilot on calm and hazard-free open water.

Use caution when operating the autopilot near hazards in the water, such as docks, pilings, and other boats.

#### CAUTION

Failure to install and maintain this equipment in accordance with these instructions could result in damage or injury.

When in use, beware of hot surfaces on the heat-sink, motor, and solenoid components.

When in use, beware the risk of entrapment or pinching from moving parts.

### Installation Preparation

The autopilot system consists of multiple components. You should familiarize yourself with all of the component mounting and connection considerations before beginning installation. You must know how the components operate together in order to correctly plan the installation on your boat.

You can consult the layout diagrams to help understand the mounting and connection considerations.

You should lay out all of the components on the boat as you plan the installation to make sure your cables will reach each component. If needed, extension cables (sold separately) for various components are available from your Garmin® dealer or from [garmin.com](http://garmin.com).

You should record the serial number of each component for registration and warranty purposes.



## Tools and Supplies Needed

- Safety glasses
- Drill and drill bits
- Jigsaw or a rotary cutting tool (for installing an optional helm control)
- Wire cutters/strippers
- Phillips and flat screwdrivers
- Cable ties
- Solder and water-tight heat shrink tubing or water-tight, heat-shrink, butt-splice connectors
- Dielectric grease
- Marine sealant
- Portable or handheld compass (to test for magnetic interference)

**NOTE:** Mounting screws are provided for the main components of the autopilot system. If the provided screws are not appropriate for the mounting surface, you must provide the correct types of screws.

## Power and Data Layout

### ⚠ WARNING

When connecting the power cable, do not remove the in-line fuse holder. To prevent the possibility of injury or product damage caused by fire or overheating, the appropriate fuse must be in place as indicated in the product specifications. In addition, connecting the power cable without the appropriate fuse in place voids the product warranty.

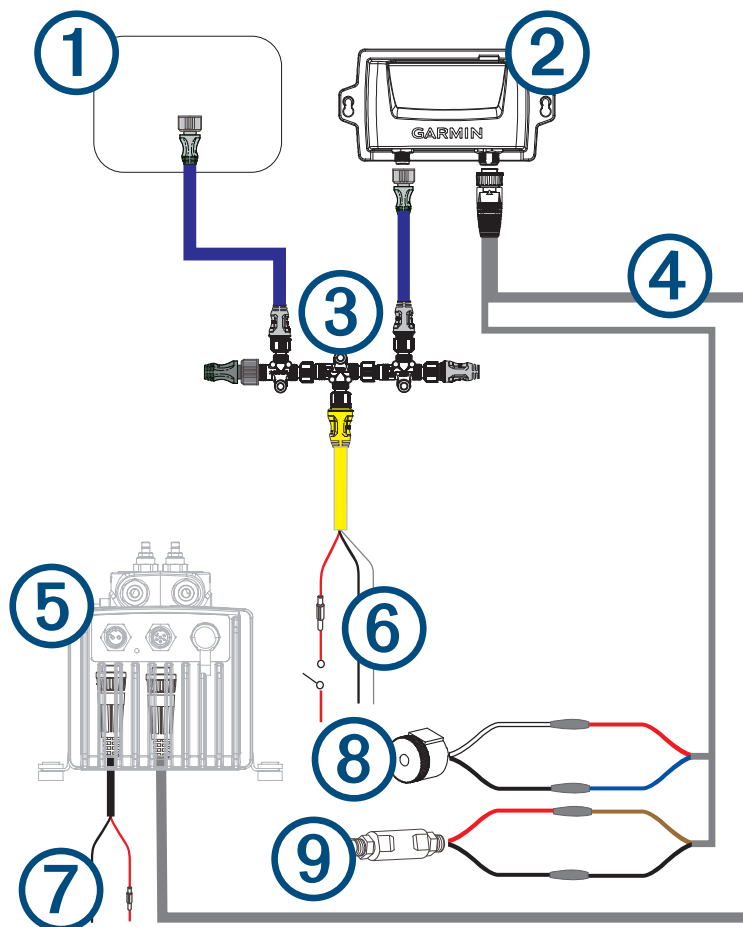

Item	Description	Important Considerations
①	Helm control	A dedicated helm control is not included in all autopilot packages. If you install the autopilot without a dedicated helm control, the autopilot CCU must be connected to the same NMEA 2000® network as a compatible Garmin chartplotter to configure and control the autopilot system.
②	CCU	You can mount the CCU in a non-submerged location near the center of the boat, in any orientation ( <i>CCU Mounting and Connection Considerations, page 6</i> ). Mount the CCU away from sources of magnetic interference.
③	NMEA 2000 network	You must connect the helm control or compatible Garmin chartplotter and the CCU to a NMEA 2000 network using the included T-connectors ( <i>NMEA 2000 Connection Considerations, page 7</i> ). If there is not an existing NMEA 2000 network on your boat, you can build one using the supplied cables and connectors ( <i>Building a Basic NMEA 2000 Network for the Autopilot System, page 12</i> ).
④	CCU cable	To extend this cable to reach the ECU, you may need to use cable extensions (sold separately) ( <i>CCU Mounting and Connection Considerations, page 6</i> ). You must connect this cable to the alarm and the Shadow Drive™ sensor.
⑤	SmartPump	This diagram shows only the electrical connections for the SmartPump. Installation details are included in the <i>SmartPump Installation Instructions</i> .
⑥	NMEA 2000 power cable	You should install this cable only if you are building a NMEA 2000 network. Do not install this cable if there is an existing NMEA 2000 network on your boat. You must connect the NMEA 2000 power cable to a 9 to 16 Vdc power source.
⑦	Pump power cable	The pump must be connected to a 12 to 24 Vdc power source. To extend this cable, use the correct wire gauge ( <i>Power Cable Extensions, page 8</i> ).
⑧	Alarm	The alarm provides audible alerts from the autopilot system, and you should install it near the primary helm station ( <i>Installing the Alarm, page 11</i> ).
⑨	Shadow Drive sensor	You must install the Shadow Drive sensor properly in the hydraulic steering line, and connect it to the CCU cable ( <i>Installing the Shadow Drive Sensor, page 11</i> ).

## Component Layout

### Single-Helm Layout

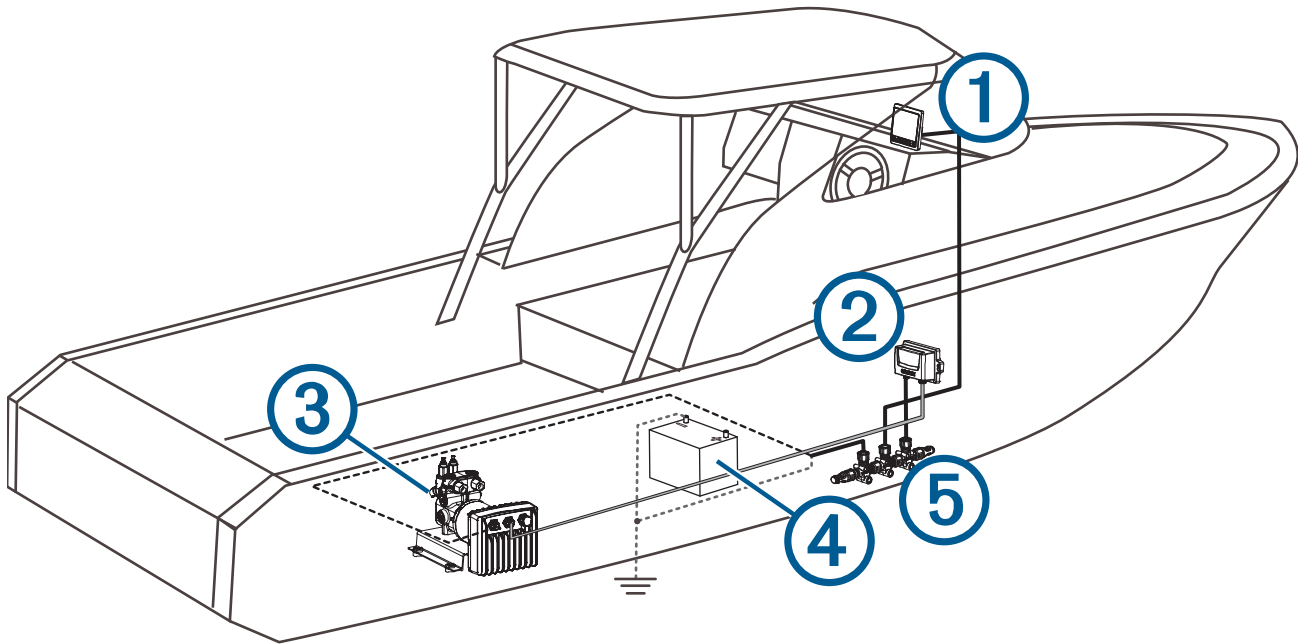

**NOTE:** This diagram is for planning purposes only. If needed, specific connection diagrams are included in the detailed installation instructions for each component.

Hydraulic connections are not shown in this diagram.

Item	Description	Important Considerations
①	Helm control	A dedicated helm control is not included in all autopilot packages. If you install the autopilot without a dedicated helm control, the autopilot CCU must be connected to the same NMEA 2000 network as a compatible Garmin chartplotter to configure and control the autopilot system.
②	CCU	You can mount the CCU in a non-submerged location near the center of the boat, in any orientation ( <a href="#">CCU Mounting and Connection Considerations, page 6</a> ). Mount the CCU away from sources of magnetic interference.
③	SmartPump	
④	12 to 24 Vdc battery	The pump must be connected to a 12 to 24 Vdc power source. To extend this cable, use the correct wire gauge ( <a href="#">Power Cable Extensions, page 8</a> ). You must connect the NMEA 2000 power cable to a 9 to 16 Vdc power source.
⑤	NMEA 2000 network	You must connect the helm control or compatible Garmin chartplotter and the CCU to a NMEA 2000 network using the included T-connectors ( <a href="#">NMEA 2000 Connection Considerations, page 7</a> ). If there is not an existing NMEA 2000 network on your boat, you can build one using the supplied cables and connectors ( <a href="#">Building a Basic NMEA 2000 Network for the Autopilot System, page 12</a> ).

## Dual-Helm Layout Guidelines

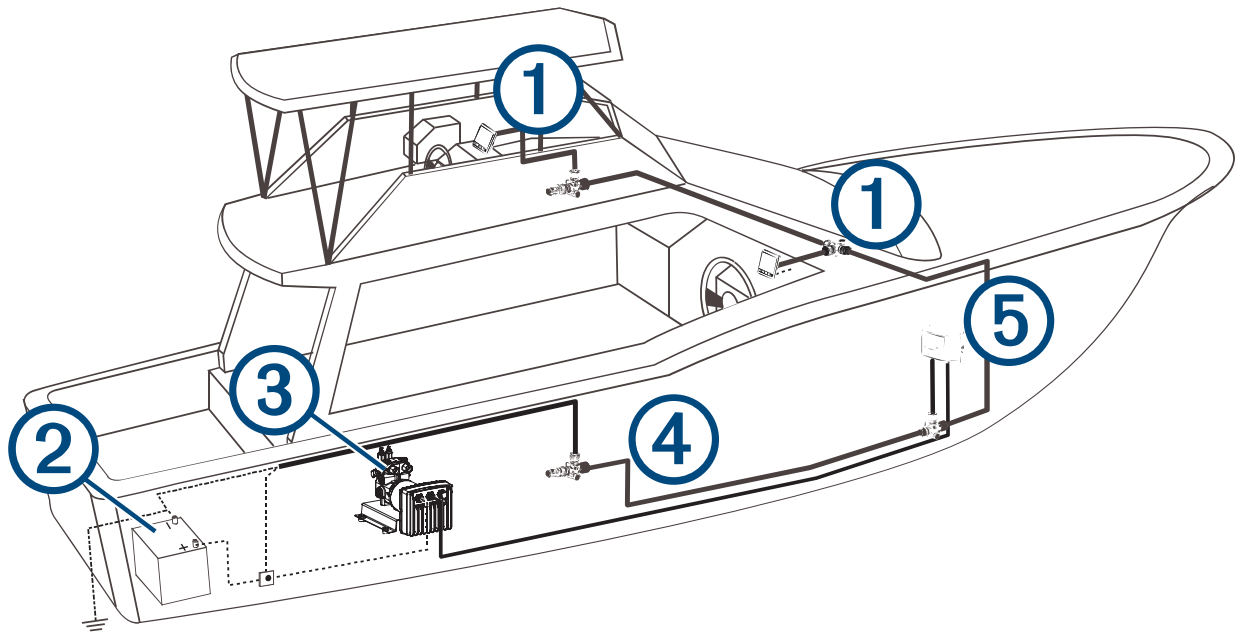

**NOTE:** This diagram is for planning purposes only. If needed, specific connection diagrams are included in the detailed installation instructions for each component.

Hydraulic connections are not shown in this diagram.

Item	Description	Important Considerations
①	Helm control	A dedicated helm control is not included in all autopilot packages. If you install the autopilot without a dedicated helm control, the autopilot CCU must be connected to the same NMEA 2000 network as a compatible Garmin chartplotter to configure and control the autopilot system.
②	12 to 24 Vdc battery	The pump must be connected to a 12 to 24 Vdc power source. To extend this cable, use the correct wire gauge ( <a href="#">Power Cable Extensions, page 8</a> ). You must connect the NMEA 2000 power cable to a 9 to 16 Vdc power source.
③	SmartPump	
④	NMEA 2000 network	You must connect the helm control or compatible Garmin chartplotter and the CCU to a NMEA 2000 network using the included T-connectors ( <a href="#">NMEA 2000 Connection Considerations, page 7</a> ). If there is not an existing NMEA 2000 network on your boat, you can build one using the supplied cables and connectors ( <a href="#">Building a Basic NMEA 2000 Network for the Autopilot System, page 12</a> ).
⑤	CCU	You can mount the CCU in a non-submerged location near the center of the boat, in any orientation ( <a href="#">CCU Mounting and Connection Considerations, page 6</a> ). Mount the CCU away from sources of magnetic interference.

### Mounting and Connection Considerations

The autopilot components connect to each other and to power using the included cables. Ensure that the correct cables reach each component and that each component is in an acceptable location before mounting or wiring any components.

## CCU Mounting and Connection Considerations

- The CCU is the primary sensor of the Reactor 40 for SmartPump autopilot system. For best performance, observe these considerations when selecting a mounting location.
  - A handheld compass should be used to test for magnetic interference in the area where the CCU is to be mounted (*Testing a Location for Magnetic Interference, page 6*).
  - The CCU should be mounted on a rigid surface for best performance.
- Mounting screws are provided with the CCU. If you use mounting hardware other than the provided screws, the hardware must be quality stainless or brass material to avoid magnetic interference with the CCU. Test any mounting hardware with a handheld compass to make sure no magnetic fields are present in the hardware.
- The CCU cable connects the CCU to the SmartPump and is 5 m (16 ft.) long.
  - If the CCU cannot be mounted within 5 m (16 ft.) of the SmartPump, extension cables are available from your local Garmin dealer or at [garmin.com](http://garmin.com).
  - This cable must not be cut.

## Finding the Best Mounting Location

- 1 Create a list of all suitable mounting locations for the CCU.  
Suitable mounting locations should not be within 60 cm (2 ft.) of the following:
  - Iron
  - Magnets
  - High-current wires
  - Intermittently-running pumps, such as head pumps and live well pumpsA large magnet, such as a subwoofer-speaker magnet, should be no closer than 1.5 m (5 ft.) to any of the mounting locations.
- 2 Locate the center of rotation of the boat, and measure the distance between the center of rotation and each of the suitable mounting locations you listed in step 1.
- 3 Select the location closest to the center of rotation.  
If more than one location is approximately the same distance from the center of rotation, you should select the location that best meets these considerations.
  - The best location is closest to the centerline of the boat.
  - The best location is lower in the boat.
  - The best location is slightly forward in the boat.

## Testing a Location for Magnetic Interference

You can use a handheld compass to test a mounting location for magnetic interference.

- 1 Hold a handheld compass in the CCU mounting location.
- 2 Move the compass six inches to the left of the location, then six inches to the right, observe the needle, and select an action:
  - If the compass needle moves more than three degrees during this step, magnetic interference is present. Select a new mounting location and repeat the test.
  - If the compass needle does not move, or moves less than three degrees, proceed to the next step.
- 3 Repeat this process while moving the compass above and below the mounting location.
- 4 Repeat this process while moving the compass in front of and behind the mounting location.

## Shadow Drive Sensor Mounting Considerations

**NOTE:** The Shadow Drive sensor is a device you install in the hydraulic steering lines of your boat. It detects when you manually take control of the helm and suspends autopilot control of the boat.

- The Shadow Drive sensor must be mounted horizontally and as level as possible, with cable ties firmly securing it in place.
- The Shadow Drive sensor must be mounted at least 305 mm (12 in.) away from magnetic materials or devices, such as speakers or electric motors.
- The Shadow Drive sensor should be mounted closer to the helm than to the pump.
- The Shadow Drive sensor should be mounted lower than the lowest helm, but higher than the pump.
- The Shadow Drive sensor must not be connected directly to the fitting at the back of the helm. There must be a length of hose between the fitting at the helm and the Shadow Drive sensor.
- The Shadow Drive sensor must not be connected directly to a hydraulic T-connector in the hydraulic line. There must be a length of hose between a T-connector and the Shadow Drive sensor.
- In a single-helm installation, there must not be a T-connector between the helm and the Shadow Drive sensor.
- In a dual-helm installation, the Shadow Drive sensor should be installed between the pump and the hydraulic T-connector that leads to the upper and lower helm, closer to the T-connector than to the pump.
- The Shadow Drive sensor must be installed in either the starboard steering line or the port steering line. The Shadow Drive sensor must not be installed in either the return line or the high-pressure line, if applicable.

## Alarm Mounting and Connection Considerations

- The alarm should be mounted near the primary helm station.
- The alarm can be mounted under the dashboard.
- If needed, the alarm wires can be extended with 28 AWG (0.08 mm<sup>2</sup>) wire.

## NMEA 2000 Connection Considerations

- The CCU and the helm control must connect to a NMEA 2000 network.
- If your boat does not already have a NMEA 2000 network, one can be built using the included NMEA 2000 cables and connectors (*Building a Basic NMEA 2000 Network for the Autopilot System, page 12*).
- To use the advanced features of the autopilot, optional NMEA 2000 devices, such as a wind sensor, a water-speed sensor, or a GPS device, can be connected to the NMEA 2000 network.

## Installation Procedures

### CAUTION

To avoid possible personal injury, always wear safety goggles, ear protection, and a dust mask when drilling, cutting, or sanding.

### NOTICE

When drilling or cutting, always check what is on the opposite side of the surface to avoid damaging the vessel.

After you have planned the autopilot installation on your boat and satisfied all of the mounting and wiring considerations for your particular installation, you can begin mounting and connecting the components.

## Helm Control Installation

A dedicated helm control is not included in all autopilot packages. If you install the autopilot without a dedicated helm control, the autopilot CCU must be connected to the same NMEA 2000 network as a compatible Garmin chartplotter to configure and control the autopilot system.

Detailed mounting instructions are included in the helm control box.

## Mounting the CCU

- 1 Determine the mounting location.
- 2 Using the CCU as a template, mark the two pilot hole locations on the mounting surface.
- 3 Using a 3 mm ( $\frac{1}{8}$  in.) bit, drill the pilot holes.
- 4 Use the included screws to attach the CCU to the mounting surface.

**NOTE:** If you use mounting hardware other than the provided screws, the hardware must be quality stainless or brass material to avoid magnetic interference with the CCU.

Test any mounting hardware with a handheld compass to make sure no magnetic fields are present in the hardware.

## Installing the Pump

The SmartPump must be installed in your hydraulic steering lines so the Reactor 40 for SmartPump autopilot can steer your boat. The package containing the SmartPump will have the correct cables, connectors, and instructions.

Follow the installation instructions provided with your pump to mount it and connect it to your hydraulic steering system correctly.

## Power Cable Extensions

If necessary, you can extend the power cable using the appropriate wire gauge for the length of the extension.

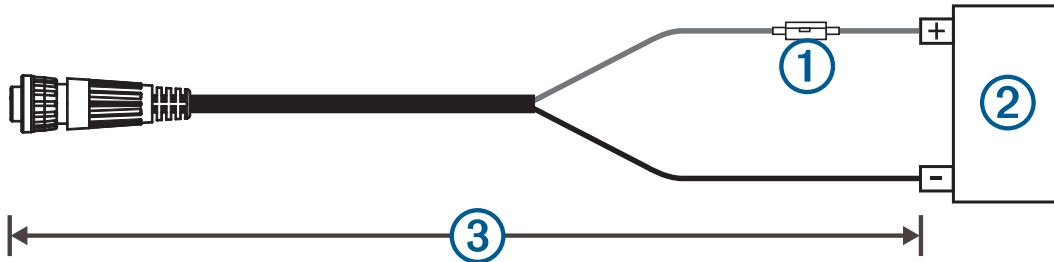

Item	Description
①	Fuse
②	Battery
③	9 ft. (2.7 m) no extension

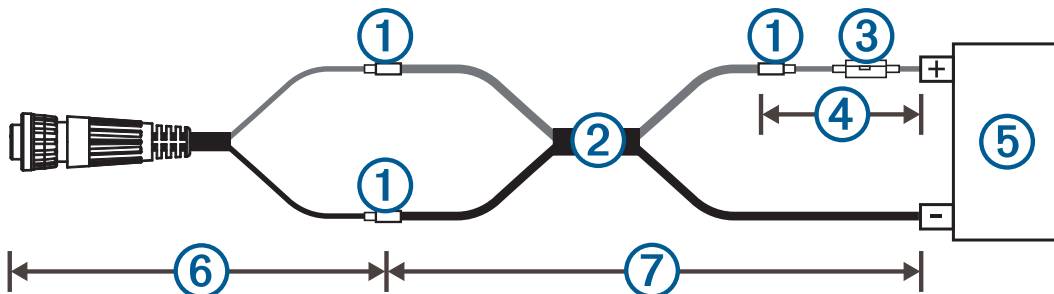



Item	Description
①	Splice
②	10 AWG (5.26 mm <sup>2</sup> ) extension wire
③	Fuse
④	8 in. (20.3 cm)
⑤	Battery
⑥	8 in. (20.3 cm)
⑦	Up to 15 ft. (4.6 m)

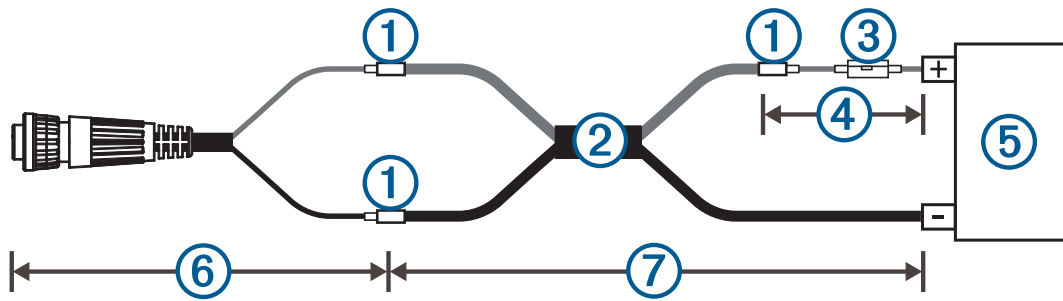

Item	Description
①	Splice
②	8 AWG (8.36 mm <sup>2</sup> ) extension wire
③	Fuse
④	8 in. (20.3 cm)
⑤	Battery
⑥	8 in. (20.3 cm)
⑦	Up to 23 ft. (7 m)

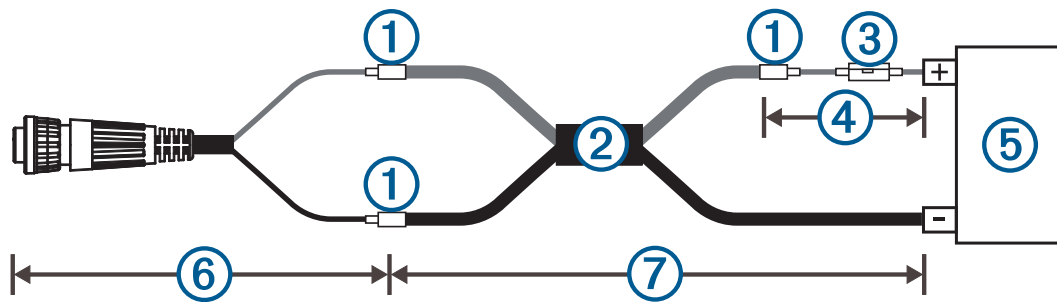

Item	Description
①	Splice
②	6 AWG (13.29 mm <sup>2</sup> ) extension wire
③	Fuse
④	8 in. (20.3 cm)
⑤	Battery
⑥	8 in. (20.3 cm)
⑦	Up to 36 ft. (11 m)

### Installing a Garmin Rudder Feedback Sensor

Installing a rudder feedback sensor, such as the GRF™ 10 (sold separately), is not necessary for the autopilot to function correctly, but doing so will increase performance, provide an on-screen rudder indication, and extend the life of the SmartPump.

Follow the installation instructions provided with your GRF rudder feedback sensor to connect it to your rudder control and autopilot system.

### Connecting the CCU

- 1 Route the connector end of the CCU cable to the SmartPump and make the connection.

#### NOTICE

You should apply dielectric grease to the pin holes on the cable connector to prevent corrosion, especially if you are using the autopilot system in saltwater.

- 2 Route the orange and blue wires from the bare-wire portion of the CCU cable to the location where you plan to install the alarm ([Installing the Alarm, page 11](#)).  
If the cable is not long enough, extend the appropriate wires with 28 AWG (0.08 mm<sup>2</sup>) wire.
- 3 Route the brown and black wires from the bare-wire portion of the CCU cable to the location where you plan to install the Shadow Drive sensor ([Installing the Shadow Drive Sensor, page 11](#)).  
If the cable is not long enough, extend the appropriate wires with 28 AWG (0.08 mm<sup>2</sup>) wire.

## Installing the Shadow Drive Sensor

### Connecting the Shadow Drive Sensor to the Hydraulic System

Before you can install the Shadow Drive sensor, you must select a location at which to connect the Shadow Drive sensor to the hydraulic steering of your boat (*Shadow Drive Sensor Mounting Considerations, page 7*).

For further assistance, consult the hydraulic-layout diagrams included with your pump.

Use hydraulic connectors (not included) to install the Shadow Drive sensor in the appropriate hydraulic line.

### Connecting the Shadow Drive Sensor to the CCU

- 1 Route the bare-wire end of the CCU cable to the Shadow Drive sensor.

If the cable is not long enough, extend the appropriate wires using 28 AWG (0.08 mm<sup>2</sup>) wire.

- 2 Using a water-tight connection method, connect the cables based on this table.

Shadow Drive Sensor Wire Color	CCU Cable Wire Color
Red (+)	Brown (+)
Black (-)	Black (-)

## Installing the Alarm

Before you can mount the alarm, you must select a mounting location (*Alarm Mounting and Connection Considerations, page 7*).

- 1 Route the alarm cable to the bare-wire end of the CCU cable.

If the cable is not long enough, extend the appropriate wires with 28 AWG (0.08 mm<sup>2</sup>) wire.

- 2 Using a water-tight connection method, connect the cables based on this table.

Alarm Wire Color	CCU Cable Wire Color
White (+)	Orange (+)
Black (-)	Blue (-)

- 3 Secure the alarm with cable ties or other mounting hardware (not included).

## NMEA 2000 and the Autopilot Components

A dedicated helm control is not included in all autopilot packages. If you install the autopilot without a dedicated helm control, the autopilot CCU must be connected to the same NMEA 2000 network as a compatible Garmin chartplotter to configure and control the autopilot system.

### NOTICE

If you are connecting to an **existing** NMEA 2000 network, identify the NMEA 2000 power cable. Only one NMEA 2000 power cable is required for the NMEA 2000 network to operate properly.

A NMEA 2000 Power Isolator (010-11580-00) should be used in installations where the existing NMEA 2000 network manufacturer is unknown.

You can connect the CCU and the optional helm control through an existing NMEA 2000 network. If you do not have an existing NMEA 2000 network on your boat, all the parts needed to build one are supplied in the autopilot package (*Building a Basic NMEA 2000 Network for the Autopilot System, page 12*).

To use the advanced features of the autopilot, optional NMEA 2000 devices, such as a GPS device, can be connected to the NMEA 2000 network.

If you are unfamiliar with NMEA 2000, you should read the *Technical Reference for NMEA 2000 Products* at [garmin.com/manuals/nmea\\_2000](http://garmin.com/manuals/nmea_2000).

## Building a Basic NMEA 2000 Network for the Autopilot System

### NOTICE

If you are installing a NMEA 2000 power cable, you must connect it to the boat ignition switch or through another in-line switch. NMEA 2000 devices will drain your battery if the NMEA 2000 power cable is connected to the battery directly.

A dedicated helm control is not included in all autopilot packages. If you install the autopilot without a dedicated helm control, the autopilot CCU must be connected to the same NMEA 2000 network as a compatible Garmin chartplotter to configure and control the autopilot system.

- 1 Connect the three T-connectors ① together side-by-side.

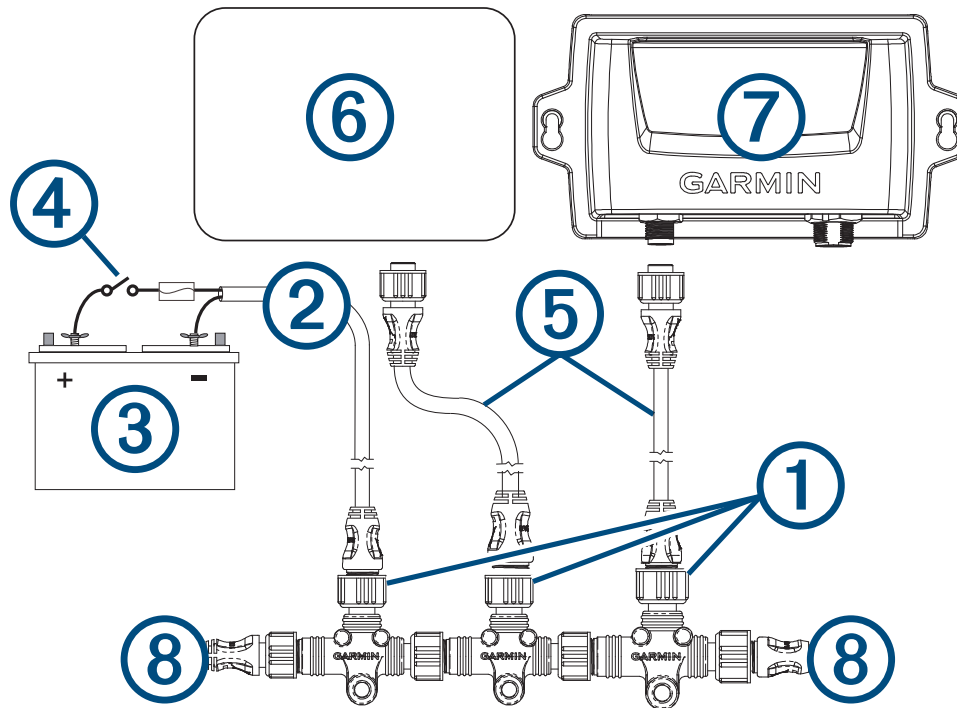

- 2 Connect the included NMEA 2000 power cable ② to a 9 to 12 Vdc power source ③ through a switch ④. You should connect the power cable to the ignition switch of the boat if possible, or route it through an inline switch (not included).  
**NOTE:** The braided drain wire (bare) on the NMEA 2000 power cable must be connected to the same ground as the black wire on the NMEA 2000 power cable.
- 3 Connect the NMEA 2000 power cable to one of the T-connectors.
- 4 Connect one of the included NMEA 2000 drop cables ⑤ to one of the T-connectors and to the helm control (optional) or to a compatible Garmin chartplotter ⑥.
- 5 Connect the other included NMEA 2000 drop cable to the other T-connector and to the CCU ⑦.
- 6 Connect the male and female terminators ⑧ to each end of the combined T-connectors.

## Connecting the Autopilot Components to an Existing NMEA 2000 Network

A dedicated helm control is not included in all autopilot packages. If you install the autopilot without a dedicated helm control, the autopilot CCU must be connected to the same NMEA 2000 network as a compatible Garmin chartplotter to configure and control the autopilot system.

### NOTICE

You should apply dielectric grease to the pin holes on the cable connectors to prevent corrosion, especially if you are using the autopilot system in saltwater.

- 1 Determine where to connect the CCU ① and the helm control (optional) ② to your existing NMEA 2000 backbone ③.

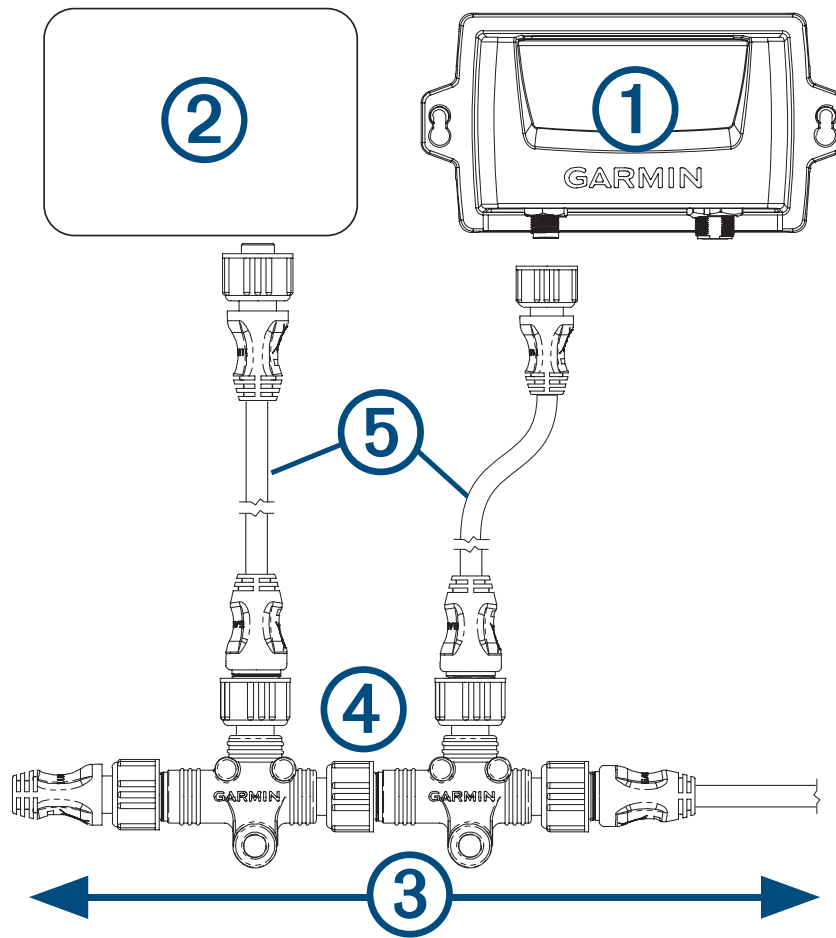

- 2 In the location where you plan to connect the CCU, disconnect one side of a NMEA 2000 T-connector ④ from the network.
- 3 If necessary, connect a NMEA 2000 backbone extension cable (not included) to the side of the disconnected T-connector to extend the NMEA 2000 network backbone.
- 4 Add an included T-connector for the CCU to the NMEA 2000 backbone by connecting it to the side of the disconnected T-connector or backbone extension cable.
- 5 Route the included drop cable ⑤ to the CCU and to the bottom of the T-connector added in step 4.  
If the included drop cable is not long enough, you can use a drop cable up to 6 m (20 ft.) long (not included).
- 6 Connect the drop cable to the CCU and the T-connector.
- 7 If needed, repeat steps 2 through 6 for the helm control (optional) or a compatible Garmin chartplotter.

## Connecting Optional NMEA 2000 Devices to the Autopilot System

You can use advanced features of the autopilot system by connecting optional NMEA 2000 compatible devices, such as a GPS device, to the NMEA 2000 network.

- 1 Add an additional T-connector (not included) to the NMEA 2000 network backbone.
- 2 Connect the optional NMEA 2000 device to the T-connector by following the instructions provided with the device.

## Bleeding the Hydraulics

### NOTICE

This is a general procedure for bleeding a hydraulic steering system. Refer to the instructions provided by the manufacturer of the steering system for more-specific information about bleeding the system.

Before you bleed the hydraulic system, you should verify that all hose connections are complete and fully tightened.

- 1 Select an option:
  - If the helm reservoir contains insufficient fluid, fill it as needed.
  - If the helm reservoir contains excess fluid, remove the excess to avoid fluid overflow during the bleeding process.
- 2 Insert a bypass hose between the cylinder bleed ports.  
**TIP:** If you use a clear plastic hose for this bypass, you can observe air bubbles during the bleeding processes.
- 3 Manually steer the helm fully to port.
- 4 Open both bypass valves at the cylinder fittings.
- 5 Open the bypass valve on the pump manifold.
- 6 Manually turn the helm slowly to port over three minutes.  
**TIP:** You can stop turning when you no longer see air moving through the bypass hose.
- 7 Turn on the autopilot system and disable the Shadow Drive sensor.  
You can refer to the owner's manual for your helm control or chartplotter for more information on disabling the Shadow Drive.
- 8 Hold  $<1^\circ$  (port) on the helm control or chartplotter for at least 10 seconds.  
**TIP:** You can stop holding  $<1^\circ$  when you no longer see air moving through the bypass hose.
- 9 Close both bypass valves at the cylinder fittings.
- 10 Close the bypass valve on the pump manifold.
- 11 If necessary, add fluid to the helm reservoir.
- 12 Repeat steps 3 through 11 for the starboard side.
- 13 Hold  $<1^\circ$  (port) on the helm control or chartplotter until steering stops and **Hydraulic Pump Stall** appears.
- 14 Hold  $1^\circ >$  (starboard) on the helm control or chartplotter until steering stops and **Hydraulic Pump Stall** appears.
- 15 Select an option:
  - If **Hydraulic Pump Stall** does not appear within 2 to 3 seconds after the cylinder stops, repeat steps 1-15 to bleed the system again.
  - If **Hydraulic Pump Stall** appears within 2 to 3 seconds after the cylinder stops, the system bleed completed successfully.

After hydraulic bleeding is complete, you can re-enable the Shadow Drive sensor.

## Configuration

The autopilot must be configured and tuned to your boat dynamics. You can use the Dockside Wizard and the Sea Trial Wizard on the helm control or a compatible Garmin chartplotter to configure the autopilot.

See the included configuration guide for more information on configuring the autopilot.

## Maintenance

### Corrosion Blocker

#### NOTICE

To ensure the long life of all parts, apply corrosion blocker to the pump at least twice yearly.

A marine-rated corrosion blocker should be applied to the pump after all hydraulic and electrical connections are made and the hydraulic system has been bled.

## Appendix

### Specifications

#### CCU

Dimensions (L × W × H)	170 × 90 × 50 mm (6.7 × 3.5 × 2 in.)
Weight	200 g (7 oz.)
Temperature range	From -15° to 70°C (from 5° to 158°F)
Material	Fully gasketed, high-impact plastic
Water rating	IEC 60529 IPX7*
CCU cable length	5 m (16 ft.)
NMEA 2000 input voltage	From 9 to 16 Vdc
NMEA 2000 LEN	4 (200 mA)

The device withstands incidental exposure to water of up to 1 m for up to 30 min. For more information, go to [www.garmin.com/waterrating](http://www.garmin.com/waterrating).

#### Alarm

Specification	Measurement
Dimensions (L×diameter)	$29/32 \times 1$ in. (23 × 25 mm)
Weight	2.4 oz. (68 g)
Temperature range	From 5°F to 140°F (from -15°C to 60°C)
Cable length	10 ft. (3.0 m)

## NMEA 2000 PGN Information

### CCU

Type	PGN	Description
Transmit and receive	059392	ISO acknowledgment
	059904	ISO request
	060928	ISO address claim
	126208	NMEA®: Command/Request/Acknowledge group function
	126464	Transmit/Receive PGN list group function
	126996	Product information
	127257	Transmit/Receive attitude data
	127251	Transmit/Receive rate of turn
Transmit only	127250	Vessel heading
Receive only	127258	Magnetic variation
	127488	Engine parameters: Rapid update
	128259	Water speed
	129025	Position: Rapid update
	129026	COG & SOG: Rapid update
	129283	Cross track error
	129284	Navigation data
	130306	Wind data

### Helm Control

A dedicated helm control is not included in all autopilot packages. To view the PGN information for a helm control device, see the product owner's manual available for download at [garmin.com/manuals/ghc50](http://garmin.com/manuals/ghc50).



## Error and Warning Messages

Error Message	Cause	Autopilot Action
Autopilot ECU Voltage is Low	The pump supply voltage has fallen below 10 Vdc for longer than 6 seconds.	Alarm sounds for 5 seconds Continues in normal operation
Autopilot is not receiving navigation data. Autopilot will hold the current heading.	The autopilot is no longer receiving valid navigation data while performing a Route To maneuver. This message also appears if navigation is stopped on a chartplotter before the autopilot is disengaged.	Alarm sounds for 5 seconds Autopilot transitions to heading hold
Connection with Autopilot Lost	The helm control has lost connection with the CCU.	N/A
Autopilot Lost Wind Data (sailboat only)	The autopilot is no longer receiving valid wind data.	Alarm sounds for 5 seconds Autopilot transitions to heading hold
Autopilot ECU High Voltage	The pump supply voltage has risen above 33.5 Vdc.	Alarm sounds for 5 seconds The ECU shuts down
Autopilot ECU Voltage has Dropped Rapidly	The SmartPump voltage has dropped quickly below 7.0 Vdc.	Alarm sounds for 5 seconds The error is cleared when the ECU voltage rises above 7.3 Vdc.
Autopilot ECU High Temperature	The SmartPump temperature has risen above 100°C (212°F).	Alarm sounds for 5 seconds The ECU shuts down
Error: Lost communication between ECU and CCU (when the autopilot is engaged)	Communication between the CCU and the SmartPump has timed out.	The helm control or chartplotter beeps, and the autopilot transitions to standby.

## Contacting Garmin Support

- Go to [support.garmin.com](https://support.garmin.com) for help and information, such as product manuals, frequently asked questions, videos, and customer support.
- In the USA, call 913-397-8200 or 1-800-800-1020.
- In the UK, call 0808 238 0000.
- In Europe, call +44 (0) 870 850 1241.

© 2022 Garmin Ltd. or its subsidiaries

Garmin® and the Garmin logo are trademarks of Garmin Ltd. or its subsidiaries, registered in the USA and other countries. Reactor™ and Shadow Drive™ are trademarks of Garmin Ltd. or its subsidiaries. These trademarks may not be used without the express permission of Garmin.

NMEA 2000® and the NMEA 2000 logo are trademarks of the National Marine Electronics Association.

