

GARMIN®

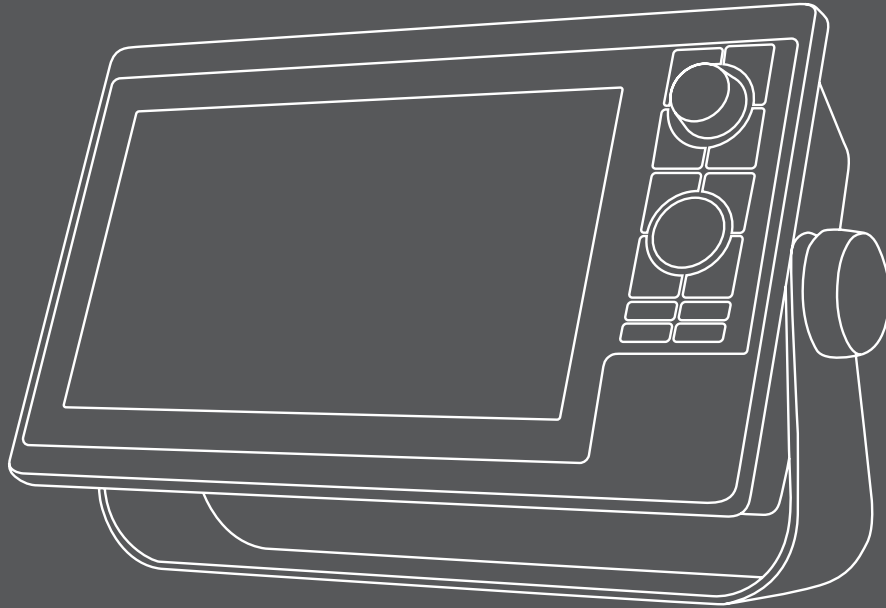

# AQUAMAP™ 10x2/12x2 SERIES

Owner's Manual

© 2017 Garmin Ltd. or its subsidiaries

All rights reserved. Under the copyright laws, this manual may not be copied, in whole or in part, without the written consent of Garmin. Garmin reserves the right to change or improve its products and to make changes in the content of this manual without obligation to notify any person or organization of such changes or improvements. Go to [Garmin.com](http://Garmin.com) for current updates and supplemental information concerning the use of this product.

Garmin®, the Garmin logo, AQUAMAP™, BlueChart®, FUSION®, g2 Vision®, MapSource®, Ultrascroll®, and VIRB® are trademarks of Garmin Ltd. or its subsidiaries, registered in the USA and other countries. Fantom™, FUSION-Link™, Garmin ClearVü™, Garmin Connect™, Garmin Helm™, Garmin LakeVü™, Garmin Quickdraw™, GCV™, GMR™, GRID™, GXM™, HomePort™, Motion-Scope™, Panoptix™, Shadow Drive™, and SmartMode™ and are trademarks of Garmin Ltd. or its subsidiaries. These trademarks may not be used without the express permission of Garmin.

The Bluetooth® word mark and logos are owned by the Bluetooth SIG, Inc. and any use of such marks by Garmin is under license. CZone™ is a trademark of Power Products, LLC. FLIR® is a registered trademark of FLIR Systems, Inc. iOS® is a registered trademark of Cisco Systems, Inc. used under license by Apple Inc. microSD® and the microSDHC logo are trademarks of SD-3C, LLC. NMEA®, NMEA 2000®, and the NMEA 2000 logo are registered trademarks of the National Marine Electronics Association. SiriusXM® is a registered trademark of SiriusXM Radio Inc. Wi-Fi® is a registered mark of Wi-Fi Alliance Corporation. Windows® is a registered trademark of Microsoft Corporation in the United States and other countries. All other trademarks and copyrights are the property of their respective owners. Other trademarks and trade names are those of their respective owners.

# Table of Contents

<b>Introduction .....</b>	<b>1</b>
AQUAMAP Dimensions .....	1
Device Overview .....	1
Keys .....	1
Protective Cover .....	2
Garmin® Support Center .....	2
Inserting Memory Cards .....	2
Software Update .....	2
Loading the New Software on a Memory Card .....	3
Updating the Device Software .....	3
GPS Satellite Signals .....	3
Selecting the GPS Source .....	3
<b>Customizing AQUAMAP .....</b>	<b>4</b>
Home Screen .....	4
Customizing Pages .....	4
Adding an Item to the Favorites Screen .....	4
Customizing the Favorites Screen .....	4
Adding a Custom Combination Screen .....	4
Editing a Combination Screen .....	4
Customizing the Combos Screen .....	5
Customizing the Data Overlays .....	5
Resetting the Station Layouts .....	5
Presets .....	5
Saving a New Preset .....	5
Managing Presets .....	5

Data Fields .....	6
Setting the Vessel Type .....	6
Adjusting the Backlight .....	6
Adjusting the Color Mode .....	6
Setting the Beeper .....	6

## **Charts and 3D Chart Views .....**

<b>Nav. Chart and Offshore Fishing Chart .....</b>	<b>7</b>
Selecting an Item on the Map Using the Device Keys .....	8
Chart Symbols .....	8
Measuring a Distance on the Chart .....	8
Creating a Waypoint on the Chart .....	8
Navigating to a Point on the Chart .....	8
Viewing Location and Object Information on a Chart .....	8
Viewing Details about Nav aids .....	9
Premium Charts .....	9
Viewing Tide Station Information .....	9
Selecting a Map .....	10
Automatic Identification System .....	10
AIS Targeting Symbols .....	10
Heading and Projected Course of Activated AIS Targets .....	11
Showing AIS and MARPA Vessels .....	11
Activating a Target for an AIS Vessel .....	12
Viewing a List of AIS and MARPA Threats .....	12
AIS Distress Signals .....	12
Turning Off AIS Reception .....	13
Chart and 3D Chart View Settings .....	13
Marks, Wpts & Tracks Settings on the Charts and Chart Views .....	13

Other Vessels Settings on the Charts and Chart Views .....	13	Deleting All Waypoints.....	22
Navigation and Fishing Chart Setup .....	13	Setting and Following a Direct Course Using Go To .....	22
Chart Appearance Settings .....	14	Tracks.....	22
Laylines Settings .....	15	Recording Tracks.....	22
Fish Eye 3D Settings.....	15	Managing the Track Log Memory During Recording.....	22
Garmin Quickdraw Contours Mapping .....	15	Configuring the Recording Interval of the Track Log .....	22
Mapping a Body of Water Using the Garmin Quickdraw Contours .....	16	Setting the Color of the Active Track.....	23
Adding a Label to a Garmin Quickdraw Contours Map.....	16	Saving the Active Track .....	23
Garmin Quickdraw Community .....	16	Clearing the Active Track.....	23
Garmin Quickdraw Contours Settings.....	18	Retracing the Active Track.....	23
<b>Navigation with AQUAMAP.....</b>	<b>19</b>	Viewing a List of Saved Tracks .....	23
Basic Navigation Questions.....	19	Editing a Saved Track .....	23
Destinations .....	19	Saving a Track as a Route .....	23
Searching for a Destination by Name .....	19	Browsing for and Navigating a Recorded Track .....	23
Selecting a Destination Using the Nav. chart.....	20	Deleting a Saved Track .....	24
Searching for a Marine Services Destination.....	20	Deleting All Saved Tracks.....	24
Stopping Navigation .....	20	Routes .....	24
Marks and Waypoints .....	20	Creating and Navigating a Route from Your Present Location.....	24
Marking Your Current Location as a Waypoint .....	20	Creating and Saving a Route .....	24
Creating a Waypoint at a Different Location .....	20	Viewing a List of Routes and Auto Guidance Paths .....	24
Creating a Waypoint on the Sonar Screen .....	20	Editing a Saved Route.....	25
Creating a Waypoint on the Chart.....	20	Browsing for and Navigating a Saved Route .....	25
Marking an SOS Location .....	20	Browsing for and Navigating Parallel to a Saved Route.....	25
Viewing a List of all Waypoints.....	21	Deleting a Saved Route .....	26
Editing a Saved Waypoint .....	21	Deleting All Saved Routes.....	26
Moving a Saved Waypoint.....	21	Auto Guidance .....	26
Browsing for and Navigating to a Saved Waypoint.....	21	Setting and Following an Auto Guidance Path .....	26
Deleting a Waypoint or an MOB.....	22	Creating and Saving an Auto Guidance Path .....	26
		Adjusting a Saved Auto Guidance Path.....	27

Canceling an Auto Guidance Calculation in Progress .....	27
Setting a Timed Arrival .....	27
Auto Guidance Path Configurations.....	27
<b>Boundaries .....</b>	<b>28</b>
Creating a Boundary .....	29
Converting a Route to a Boundary.....	29
Converting a Track to a Boundary .....	29
Editing a Boundary .....	29
Setting a Boundary Alarm .....	29
Deleting a Boundary.....	29
Synchronizing User Data Across the Garmin Marine Network .....	29
Deleting All Saved Waypoints, Routes, and Tracks .....	30
<b>Sailing Features .....</b>	<b>30</b>
Setting the Vessel Type .....	30
Sail Racing.....	30
Starting Line Guidance.....	30
Starting the Race Timer.....	31
Stopping the Race Timer.....	31
Setting the Distance between the Bow and the GPS Antenna.....	31
Laylines Settings.....	31
Setting the Keel Offset.....	32
Sailboat Autopilot Operation .....	32
Wind Hold .....	32
Tack and Gybe.....	33
Heading Line and Angle Markers .....	33
Setting the Heading and Course Over Ground Lines.....	34
Turning on Angle Markers .....	34

<b>Sonar Fishfinder .....</b>	<b>34</b>
Traditional Sonar View .....	35
Split-Zoom Sonar View.....	35
Split-Frequency Sonar View.....	35
Traditional 50/77/200 kHz Sonar.....	35
CHIRP Sonar.....	36
Garmin ClearVü Sonar View.....	36
ClearVü Scanning Sonar.....	37
SideVü Sonar View .....	37
SideVü Scanning Technology .....	38
Measuring Distance on the Sonar Screen .....	38
Panoptix Sonar Views.....	38
LiveVü Down Sonar View.....	38
LiveVü Forward Sonar View.....	39
RealVü 3D Historical Sonar View.....	39
RealVü 3D Down Sonar View .....	40
RealVü 3D Forward Sonar View .....	40
FrontVü Sonar View .....	40
Changing the Sonar View .....	40
Selecting the Transducer Type .....	40
Calibrating the Compass .....	41
Pausing the Sonar Display .....	41
Creating a Waypoint on the Sonar Screen.....	41
Viewing Sonar History.....	41
Stopping the Transmission of Sonar Signals .....	41
Sonar Sharing .....	41
Selecting a Sonar Source .....	42
Renaming a Sonar Source.....	42

Adjusting the Level of Detail .....	42	LiveVü and FrontVü Appearance Settings .....	52
Adjusting the Color Intensity .....	42	RealVü Appearance Settings .....	52
Sonar Frequencies .....	43	Panoptix Transducer Installation Settings.....	52
Selecting Frequencies.....	43	<b>Radar .....</b>	<b>54</b>
Creating a Frequency Preset .....	43	Transmitting Radar Signals.....	54
Adjusting the Zoom on the Sonar Screen .....	44	Stopping the Transmission of Radar Signals .....	54
Auto .....	44	Setting Up the Timed Transmit Mode .....	54
Bottom Lock.....	44	Enabling and Adjusting a Radar No Transmit Zone.....	54
Shift Zoom .....	44	Adjusting the Radar Range.....	55
Target Expansion .....	44	Tips for Selecting a Radar Range.....	55
Adjusting the Range of the Depth or Width Scale .....	44	Marking a Waypoint on the Radar Screen .....	55
Traditional, Garmin ClearVü, and SideVü Sonar Setup.....	45	MotionScope™ Doppler Radar Technology .....	55
Setting the Scroll Speed.....	45	Enabling a Guard Zone.....	56
Sonar Noise Rejection Settings .....	45	Defining a Circular Guard Zone .....	56
Sonar Appearance Settings .....	47	Defining a Partial Guard Zone.....	56
Sonar Alarms .....	48	Disabling a Guard Zone .....	56
Advanced Sonar Settings.....	48	MARPA.....	56
Transducer Installation Settings .....	49	MARPA Targeting Symbols .....	57
Sonar Recordings .....	49	Assigning a MARPA Tag to an Object.....	57
Recording the Sonar Display .....	49	Removing a MARPA Tag from a Targeted Object.....	57
Stopping the Sonar Recording.....	49	Viewing Information about a MARPA-tagged Object .....	57
Deleting a Sonar Recording .....	49	Viewing a List of AIS and MARPA Threats.....	57
Playing Sonar Recordings.....	50	Showing AIS Vessels on the Radar Screen.....	57
Panoptix Sonar Setup.....	50	VRM and EBL.....	58
Adjusting the RealVü Viewing Angle and Zoom Level.....	50	Professional Mode .....	58
RealVü Sonar Settings.....	50	Radar Overlay .....	58
LiveVü and FrontVü Sonar Settings.....	51	Radar Overlay and Chart Data Alignment .....	58
RealVü Appearance Settings .....	52		

Echo Trails .....	59	Sharing and Managing User Data .....	65
Turning on Echo Trails.....	59	Copying Waypoints, Routes, and Tracks from HomePort to AQUAMAP ..	65
Adjusting the Length of the Echo Trails .....	59	Selecting a File Type for Third-Party Waypoints and Routes .....	65
Clearing the Echo Trails .....	59	Copying Data from a Memory Card .....	65
Optimizing the Radar Display .....	59	Copying Waypoints, Routes, and Tracks to a Memory Card.....	65
Adjusting Gain on the Radar Screen Automatically .....	59	Copying Built-In Maps to a Memory Card.....	65
Adjusting Gain on the Radar Screen Manually.....	60	Backing Up Data to a Computer .....	65
Minimizing Nearby Large-Object Interference .....	60	Restoring Backup Data to AQUAMAP .....	66
Minimizing Side-Lobe Interference on the Radar Screen.....	60	Saving System Information to a Memory Card .....	66
Adjusting Sea Clutter on the Radar Screen Automatically .....	60	Digital Selective Calling .....	66
Adjusting Sea Clutter on the Radar Screen Manually .....	61	Networked AQUAMAP and VHF Radio Functionality.....	66
Adjusting Rain Clutter on the Radar Screen.....	61	Turning On DSC .....	66
Reducing Cross Talk Clutter on the Radar Screen .....	61	DSC List.....	66
Radar Options Menu.....	62	Incoming Distress Calls.....	67
Radar Setup Menu.....	62	Position Tracking .....	67
Radar Appearance Settings .....	62	Individual Routine Calls.....	68
Radar Installation Settings .....	63	Warning Manager .....	69
Selecting a Different Radar Source .....	63	Viewing Messages .....	69
<b>Nav Info .....</b>	<b>64</b>	Sorting and Filtering Messages.....	69
Tide, Current, and Celestial Information.....	64	Saving Messages to a Memory Card.....	69
Tide Station Information .....	64	Clearing all of the Messages .....	69
Current Station Information .....	64	<b>Gauges and Graphs.....</b>	<b>69</b>
Celestial Information.....	64	Viewing the Gauges.....	69
Viewing Tide Station, Current Station, or Celestial Information for a Different		Changing the Data Shown in a Gauge .....	69
Date .....	64	Customizing the Gauges .....	69
Viewing Information for a Different Tide or Current Station.....	64	Customizing Engine Gauge and Fuel Gauge Limits .....	70
Viewing Almanac Information from the Nav. chart .....	65	Viewing Engine and Fuel Gauges .....	70
		Selecting the Number of Engines Shown in Gauges .....	70

Customizing the Engines Shown in Gauges .....	70	Enabling and Disabling Zones .....	75
Enabling Status Alarms for Engine Gauges .....	71	Muting the Media Volume.....	75
Enabling Some Engine Gauge Status Alarms.....	71	VHF Radio.....	75
Setting the Fuel Alarm.....	71	Scanning VHF Channels.....	75
Setting the Fuel Capacity of the Vessel.....	71	Adjusting the VHF Squelch .....	75
Synchronizing the Fuel Data with the Actual Vessel Fuel.....	71	Radio.....	75
Viewing the Wind Gauges .....	71	Setting the Tuner Region.....	76
Configuring the Sailing Wind Gauge.....	72	Changing the Radio Station .....	76
Configuring the Speed Source.....	72	Changing the Tuning Mode .....	76
Configuring the Heading Source of the Wind Gauge .....	72	Presets.....	76
Customizing the Close-Hauled Wind Gauge .....	72	DAB Playback .....	76
Viewing Trip Gauges.....	72	Setting the DAB Tuner Region.....	76
Resetting Trip Gauges.....	72	Scanning for DAB Stations.....	76
Viewing Graphs.....	73	Changing DAB Stations .....	77
Setting the Graph Range and Time Scales .....	73	DAB Presets .....	77
Setting Weather Alarm .....	73	Setting the Device Name.....	77
Battery Management .....	73	Updating the Media Player Software.....	77
Setting Up the Battery Management Page .....	73	<b>Viewing Video.....</b>	<b>78</b>
<b>Media Player.....</b>	<b>74</b>	Selecting a Video Source .....	78
Opening the Media Player .....	74	Alternating Among Multiple Video Sources.....	78
Buttons.....	74	Networked Video Devices.....	78
Selecting the Media Source.....	74	Using Video Presets on Networked Video Cameras .....	78
Playing Music.....	75	Camera Settings.....	79
Browsing for Music.....	75	Video Settings.....	79
Setting a Song to Repeat .....	75	Associating the Camera to a Video Source .....	79
Setting All Songs to Repeat .....	75	Video Camera Movement Control.....	79
Setting Songs to Shuffle.....	75	Creating a Combination with Video Functions .....	80
Adjusting the Volume .....	75	Configuring the Video Appearance.....	80

<b>Autopilot .....</b>	<b>81</b>	Preferences Settings.....	86
Opening the Autopilot Screen .....	81	Units Settings .....	86
Engaging the Autopilot.....	81	Navigation Settings.....	86
Adjusting the Heading with the AQUAMAP in Step Steering Mode .....	81	Communications Settings.....	88
Autopilot Bar.....	82	NMEA 0183 Settings .....	88
Adjusting the Step Steering Increment .....	82	NMEA 2000 Settings .....	89
Setting the Power Saver.....	82	Marine Network .....	89
Enabling Shadow Drive™ .....	82	Setting Alarms .....	89
Steering Patterns .....	82	Navigation Alarms.....	89
Following the U-Turn Pattern .....	82	System Alarms.....	89
Setting Up and Following the Circles Pattern .....	82	Collision Alarm.....	89
Setting Up and Following the Zigzag Pattern .....	83	Sonar Alarms .....	90
Following the Williamson Turn Pattern.....	83	Weather Alarms .....	90
Cancelling a Steering Pattern .....	83	Fuel Alarm.....	90
Controlling the VIRB® Action Camera with the AQUAMAP.....	83	My Vessel Settings.....	90
VIRB Action Camera Settings .....	83	Setting the Keel Offset.....	91
VIRB Action Camera Video Setup Settings .....	83	Setting the Water Temperature Offset.....	91
Adding the VIRB Action Camera Controls to Other Screens.....	84	Calibrating a Water Speed Device .....	92
Controlling the VIRB Action Camera Video Playback.....	84	Other Vessels Settings .....	92
Starting a VIRB Video Slideshow.....	84	Restoring the Original AQUAMAP Factory Settings.....	92
<b>Communication with Wireless Devices .....</b>	<b>85</b>	<b>Appendix.....</b>	<b>93</b>
Using the Garmin Helm Application with the AQUAMAP.....	85	Registering Your Device .....	93
<b>Device Configuration.....</b>	<b>85</b>	Digital Switching.....	93
Turning On the AQUAMAP Automatically .....	85	Pairing the GRID Remote Input Device with the AQUAMAP .....	93
System Settings .....	85	Pairing the GRID Device with the AQUAMAP from the AQUAMAP.....	93
Viewing System Software Information .....	85	Pairing the GRID Device with the AQUAMAP from the GRID Device .....	93
Station Settings .....	86	Rotating the GRID Joystick .....	94

Cleaning the Screen .....	94
Viewing Images on a Memory card .....	94
Screenshots .....	94
Capturing Screenshots.....	94
Copying Screenshots to a Computer.....	94
Troubleshooting .....	94
My device will not acquire GPS signals .....	94
My device will not turn on or keeps turning off.....	95
My device is not creating waypoints in the correct location.....	95
Specifications .....	95
Specifications .....	95
NMEA 2000 PGN Information .....	96
NMEA 0183 Information .....	97
物質宣言 .....	98
Software License Agreement.....	98

# Introduction

## ⚠ WARNING

See the *Important Safety and Product Information* guide in the product box for product warnings and other important information.

Not all features are available on all models.

## AQUAMAP Dimensions

AQUAMAP 10x2 Series

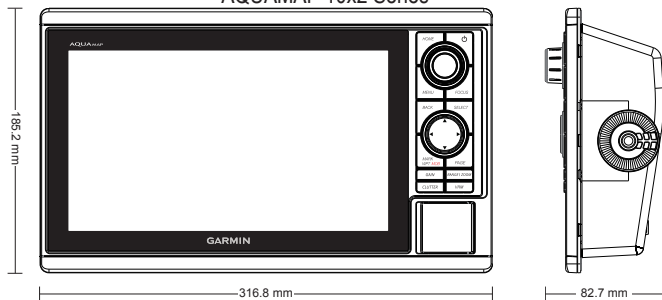

AQUAMAP 12x2 Series

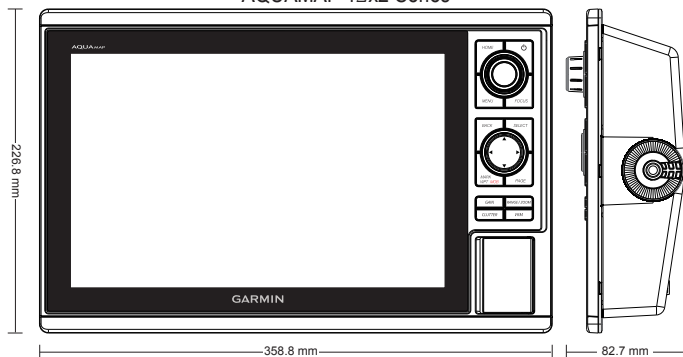

# Device Overview

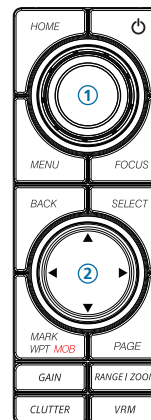

## Keys

	Hold to turn the device on or off. Press to adjust the backlight, adjust the color mode, configure colors, and enable and disable sonar transmission.
HOME	Press to return to the home screen.
MENU	Press to open or close the options menu for each page.
FOCUS	Press to move the highlight to a different section of a page. Press to move the highlight to a different function or window on a combination page.
① Knob	Rotate to zoom in or out of a view. Rotate to highlight options in menus. Press to select a highlighted option.
SELECT	Press to select options and acknowledge messages.
BACK	Press to return to the previous screen.

MARK WPT MOB	From a 2D chart or sonar page with the sonar paused, press to mark your cursor position as a mark. From a 2D chart with the cursor invisible and no menu shown, press to mark your boat position as a mark. From any other page, press to mark your boat position as a mark. From a 2D chart or sonar page with the sonar paused, hold to mark your cursor position as a waypoint. From a 2D chart with the cursor invisible and no menu shown, hold to mark your boat position as a waypoint. From any other page, hold to mark your boat position as a waypoint. Hold to open the man overboard (MOB) option.
PAGE	Press to switch through Favorites screens.
② Arrows	Press to scroll, highlight options, and move the cursor.
RANGE / ZOOM	On a sonar screen, press to open the range menu. On a sonar screen, hold to open the zoom menu.
GAIN	On a sonar or radar screen, press to open the gain menu.
CLUTTER	On a sonar or radar screen, press to open the clutter menu.
VRM	On a sonar screen, press to show or hide the depth line. On a radar screen, press to open the VRM menu.

## Protective Cover

The protective cover protects the screen when the device is not in use.

To remove the cover, hold the cover at the tab ①, and pull forward.



## Garmin® Support Center

Go to [support.garmin.com](https://support.garmin.com) for help and information, such as product manuals, frequently asked questions, videos, software updates, and customer support.

## Inserting Memory Cards

You can use optional memory cards with AQUAMAP. Map cards allow you to view high-resolution satellite imagery and aerial reference photos of ports, harbors, marinas, and other points of interest. You can use blank memory cards to record Garmin Quickdraw™ Contours mapping, record sonar (with a compatible transducer), and transfer data such as waypoints and routes to another compatible AQUAMAP or a computer.

This device supports FAT32 memory cards of up to 32 GB of storage.

- 1 Open the access flap or door ① on the front of AQUAMAP.

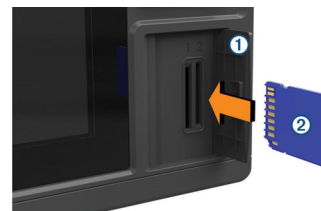

- 2 Insert the memory card ②.
- 3 Press the card in until it clicks.
- 4 Close the door.

## Software Update

You may need to update the device software when you install the device or add an accessory to the device.

Before you update the software, you can check the software version installed on your device. Then, you can go to [Garmin.com/support/software/marine](https://Garmin.com/support/software/marine).

[html](#), select See All Devices in this Bundle, and compare the installed software version to the software version listed for your product.

If the software on your device is older than the one listed on the website, follow the steps to load the software on a memory card, and then update the device software.

## Loading the New Software on a Memory Card

You must copy the software update to a memory card using a computer that is running Windows® software.

**NOTE:** You can contact Garmin customer support to order a preloaded software update card if you do not have a computer with Windows software.

- 1 Insert a memory card into the card slot on the computer.
- 2 Go to [Garmin.com/support/software/marine.html](http://Garmin.com/support/software/marine.html).

**TIP:** You can also download updated owner's manuals to load on the AQUAMAP from this web page.

- 3 Select **GPSMAP Series with SD Card**.
- 4 Select **Download** next to **GPSMAP Series with SD Card**.
- 5 Read and agree to the terms.
- 6 Select **Download**.
- 7 Choose a location, and select **Save**.
- 8 Double-click the downloaded file.

A Garmin folder containing the software update is created in the selected location. A dialog box opens to assist in transferring the software update to a memory card.

- 9 Select **Next**.
- 10 Select the drive associated with the memory card, and select **Next > Finish**.

A Garmin folder containing the software update is created on the memory card. The software update can take several minutes to load onto the memory

card.

## Updating the Device Software



- 1 Turn on AQUAMAP.
- 2 After the home screen appears, insert the memory card into the card slot.  
**NOTE:** In order for the software update instructions to appear, the device must be fully booted before the card is inserted.
- 3 Follow the on-screen instructions.
- 4 Wait several minutes while the software update process completes.
- 5 When prompted, leave the memory card in place and restart AQUAMAP manually.

- 6 Remove the memory card.

**NOTE:** If the memory card is removed before the device restarts fully, the software update is not complete.

## GPS Satellite Signals

When you turn on AQUAMAP, the GPS receiver must collect satellite data and establish the current location.

When AQUAMAP acquires satellite signals,  appears at the top of the Home screen. When AQUAMAP loses satellite signals,  disappears and a flashing question mark appears over  on the chart.

For more information about GPS, go to [Garmin.com/aboutGPS](http://Garmin.com/aboutGPS).

## Selecting the GPS Source

You can select your preferred source for GPS data, if you have more than one GPS source.

- 1 Select **Settings > System > GPS > Source**.
- 2 Select the source for GPS data.

# Customizing AQUAMAP

## Home Screen

The home screen provides access to all of the features in the device. The features are dependent on the accessories you have connected to the device.

When viewing another screen, you can return to the home screen by pressing **HOME**. You can customize the layout of the screens and the items shown on the home screen.

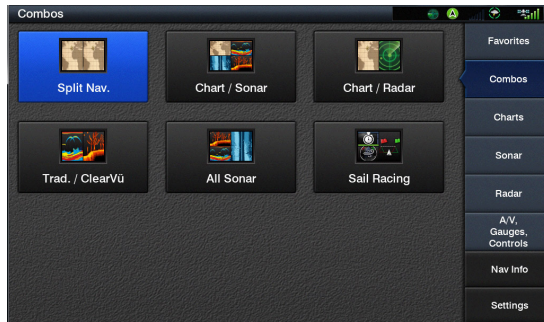

Item	Description
Favorites	Shortcuts such as chart, combination screen, or gauge.
Combos	Combination screens for simultaneous views.
Charts	Chart views such as navigation, fishing, or forecast.
Sonar	Sonar views such as ClearVü, SideVü, or LiveVü.
Radar	Radar views such as Single Range or Dual Overlay.
A/V, Gauges, Controls	Functions such as wind monitor, media playback, or control switches.
Settings	System settings and preferences.

## Customizing Pages

### Adding an Item to the Favorites Screen

From the Home screen, highlight an item, and hold **SELECT** to add it to your Favorites screen.

### Customizing the Favorites Screen

You can rearrange or remove items on the Favorites screen.

- 1 From the Favorites screen, press **MENU**.
- 2 Select an option:
  - To rearrange an item, select **Rearrange**, select an item, and use the arrow keys to select the new location.
  - To remove an item, select **Remove Favorite**, and select the item to remove.  
**TIP:** You can also remove an item by highlighting an item on your Favorites screen, and holding **SELECT**.

### Adding a Custom Combination Screen

You can create a custom combination screen to suit your needs.

- 1 From the Combos screen, press **MENU**.
- 2 Select **Add Combo**, and follow the on-screen instructions.

### Editing a Combination Screen

- 1 From the Combos screen, press **MENU**.
- 2 Select **Edit Combo**, and select one of the combination screen.
- 3 Select an option:
  - To change the name, select **Name**, and enter a new name.
  - To change the arrangement of the information on the screen, select **Layout**, and select a new layout.

- To customize the data shown on the screen, select **Overlays**, and select an option.
- To resize the information areas shown on the screen, use the arrow keys, and press **FOCUS** to exit.

## Customizing the Combos Screen

You can rearrange or remove items on the Combos screen.

- 1 From the Combos screen, press **MENU**.
- 2 Select an option:
  - To rearrange an item, select **Rearrange**, select an item, and use the arrow keys to select the new location.
  - To remove an item, select **Delete Combo**, and select the item to remove.

## Customizing the Data Overlays

You can customize additional data shown on a screen.

- 1 Select an option based on the type of screen you are viewing:
  - From a full screen view, press **MENU**, and select **Edit Overlays**.
  - From the Combos screen, press **MENU**, select **Edit Combo**, select a combination view, and select **Overlays**.

**TIP:** To quickly change the data shown in an overlay box, hold the overlay box.
- 2 Select an item to customize the data and data bar:
  - To change the data shown in an overlay box, select the overlay box, select the new data to show, and select **BACK**.
  - To select the location and layout of the data overlay bar, select **Data**, and select an option.
  - To customize the information shown when navigating, select **Navigation**, and select an option.

- To turn on other data bars, like the media controls, select **Top Bar** or **Bottom Bar**, and select the necessary options.

### 3 Select **Done**.

## Resetting the Station Layouts

You can restore the factory default layouts for all stations.

Select **Settings > System > Station Information > Reset Stations**.

## Presets

A preset is a collection of settings that optimize the screen or view. You can use particular presets to optimize groups of settings for your activity. For example, some settings might be optimal for when you are fishing, and others might be optimal for when you are cruising. Presets are available on some screens, such as charts, sonar views, and radar views.

To select a preset for a compatible screen, select **MENU > ⚙️★**, and select the preset.

When you are using a preset and you make changes to the settings or view, you can save the changes to the preset or create a new preset based on the new customizations.

## Saving a New Preset

After you have customized the settings and view of a screen, you can save the customization as a new preset.

- 1 From a compatible screen, change the settings and view.
- 2 Select **MENU > ⚙️★ > Save > New**.
- 3 Enter a name, and select **Done**.

## Managing Presets

You can customize the pre-loaded presets and edit presets you created.

- 1 From a compatible screen, select **MENU > ⚙️★ > Manage**.

- 2 Select a preset.
- 3 Select an option:
  - To rename the preset, select **Rename**, enter a name, and select **Done**.
  - To edit the preset, select **Edit**, and update the preset.
  - To delete the preset, select **Delete**.
  - To reset all presets to factory settings, select **Reset All**.

## Data Fields

Data fields display multiple types of information in one area, such as depth, heading, and bearing. Some data fields require you to be navigating or require a connection to sensors to display data. For example, a temperature sensor must be connected to the AQUAMAP to display the temperature data field.

The data fields on a page depend on the type of data associated with that page. For example, a sonar page automatically displays sonar-related information such as Depth.

You can configure the data fields that display on a page. Select **MENU > Edit Overlays**.

GPS Speed <b>0.00</b> k h	GPS Heading <b>004</b> ° M	Depth <b>23.5</b> m
Dist. to Dest. <b>1305</b> k m	Arrival -- : --	Bearing <b>004</b> ° M

## Setting the Vessel Type

You can select your boat type to configure AQUAMAP settings and to use features customized for your boat type.

- 1 Select **Settings > My Vessel > Vessel Type**.
- 2 Select an option.

## Adjusting the Backlight

- 1 Select **Settings > System > Sounds and Display > Backlight**.  
**TIP:** Press  from any screen to open the backlight settings.
- 2 Adjust the backlight.

## Adjusting the Color Mode

- 1 Select **Settings > System > Sounds and Display > Color Mode**.  
**TIP:** Select  > **Color Mode** from any screen to access the color settings.
- 2 Select an option.

## Setting the Beeper

You can set when the device makes sounds.

- 1 Select **Settings > System > Beeper**.
- 2 Select an option:
  - To have the device beep when you select an item and when an alarm is triggered, select **Key and Alarm**.
  - To have the device beep only when alarms are triggered, select **Alarms Only**.

# Charts and 3D Chart Views

The charts and 3D chart views that are available depend on the map data and accessories used.

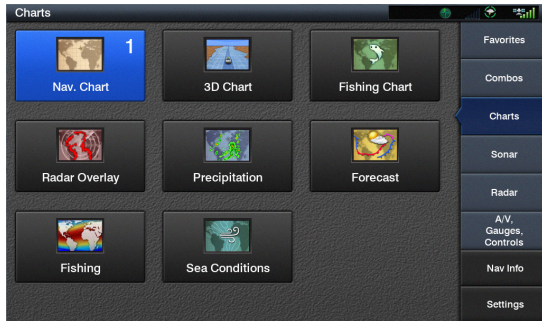

You can access the charts and 3D chart views by selecting Charts.

**Nav. Chart:** Shows navigation data available on your pre-loaded maps and from supplemental maps, if available. The data includes buoys, lights, cables, depth soundings, marinas, and tide stations in an overhead view.

**3D Chart:** Provides a view from above and behind the boat (according to your course) and provides a visual navigation aid. This view is helpful when navigating tricky shoals, reefs, bridges, or channels, and is beneficial when trying to identify entry and exit routes in unfamiliar harbors or anchorages.

**Fish Eye 3D:** Provides an underwater view that visually represents the sea floor according to the chart information. When a sonar transducer is connected, suspended targets (such as fish) are indicated by red, green, and yellow spheres. Red indicates the largest targets and green indicates the smallest.

**Fishing Chart:** Provides a detailed view of the bottom contours and depth soundings on the chart. This chart removes navigational data from the chart, provides detailed bathymetric data, and enhances bottom contours

for depth recognition. This chart is best for offshore deep-sea fishing.

**NOTE:** The offshore Fishing chart is available with premium charts, in some areas.

**Radar Overlay:** Superimposes radar information on the Nav. chart or the Fishing chart, when AQUAMAP is connected to a radar. This feature is not available with all models.

**Precipitation:** Precipitation ranging from very light rain and snow, up to strong thunderstorms, is indicated in varying shades and colors. Precipitation is shown either independently or with other weather information.

**Forecast:** The Forecast chart shows city forecasts, marine forecasts, warnings, hurricane warnings, METARS, county warnings, weather fronts and pressure centers, surface pressure, and weather buoys.

**Fishing:** The weather Fishing chart shows present water temperature, present surface pressure conditions, and fishing forecasts.

**Sea Conditions:** The Sea Conditions feature shows information about surface conditions, including winds, wave height, wave period, and wave direction.

## Nav. Chart and Offshore Fishing Chart

**NOTE:** The offshore Fishing chart is available with premium charts, in some areas.

The Navigation and Fishing charts allow you to plan your course, view map information, and follow a route. The Fishing chart is for offshore fishing.

To open the Nav. chart, select **Charts > Nav. Chart**.

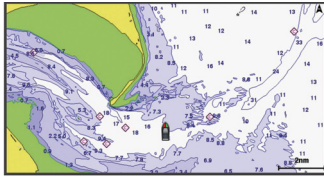

To open the Fishing chart, select **Charts > Fishing**.

### Selecting an Item on the Map Using the Device Keys

- 1 From a chart or 3D chart view, use the arrow keys to move the cursor.
- 2 Press **SELECT**.

### Chart Symbols

This table contains some of the common symbols you might see on the detailed charts.

Icon	Description
	Buoy
	Information
	Marine services
	Tide station
	Current station
	Overhead photo available
	Perspective photo available

Other features common to most charts include depth contour lines, intertidal zones, spot soundings (as depicted on the original paper chart), navigational aids and symbols, obstructions, and cable areas.

### Measuring a Distance on the Chart

- 1 From a chart or the Radar overlay, select a location.
- 2 Press **SELECT > Measure Distance**.

A push pin appears on the screen at your present location. The distance and angle from the pin is listed in the corner.

**TIP:** To reset the pin and measure from the current location of the cursor, press **SELECT**.

### Creating a Waypoint on the Chart

- 1 From a chart or a 3D chart view, select a location or object.
- 2 Press **SELECT > Create Waypoint**.

### Navigating to a Point on the Chart

- 1 From the Nav. chart or Fishing chart, select a location.
- 2 Press **SELECT > Navigate To**.

### Viewing Location and Object Information on a Chart

You can view information about a location or an object on the Nav. chart or the Fishing chart.

**NOTE:** The offshore Fishing chart is available with premium charts, in some areas.

- 1 From the Nav. chart or Fishing chart, select a location or object.
 

A list of options appears along the right side of the chart. The options that appear vary based on the location or object you selected.
- 2 Select an option:
  - To navigate to the selected location, select **Navigate To**.
  - To mark a waypoint at the cursor location, select **Create Waypoint**.
  - To view the distance and bearing of the object from your current location, select **Measure Distance**.

The distance and bearing appear on the screen. Press **SELECT** to measure from a location other than your current location.

- To view tide, current, celestial, chart notes, or local services information near the cursor, select **Information**.

## Viewing Details about Nav aids

From the Nav. chart, 3D chart, Fish Eye 3D chart, or Fishing chart, you can view details about various types of navigation aids, including beacons, lights, and obstructions.

**NOTE:** The offshore Fishing chart is available with premium charts, in some areas.

**NOTE:** Mariner's Eye 3D and Fish Eye 3D chart views are available with premium charts, in some areas.

- 1 From a chart or 3D chart view, select a nav aid.
- 2 Select the name of the nav aid.

## Premium Charts

### CAUTION

The Auto Guidance feature is based on electronic chart information. That data does not ensure obstacle and bottom clearance. Carefully compare the course to all visual sightings, and avoid any land, shallow water, or other obstacles that may be in your path.

**NOTE:** Not all models support all charts.

Optional premium charts, such as BlueChart® g2 Vision®, allow you to get the most out of your AQUAMAP. In addition to detailed marine charting, premium charts may contain these features, which are available in some areas.

**Mariner's Eye 3D:** Provides a view from above and behind the boat for a three-dimensional navigation aid.

**Fish Eye 3D:** Provides an underwater, three-dimensional view that visually

represents the sea floor according to the information on the chart.

**Fishing Charts:** Shows the chart with enhanced bottom contours and without navigational data. This chart works well for offshore deep-sea fishing.

**High Resolution Satellite Imagery:** Provides high-resolution satellite images for a realistic view of the land and water on the Nav. chart.

**Aerial Photos:** Shows marinas and other navigationally significant aerial photos to help you visualize your surroundings.

**Detailed Roads and POI data:** Shows detailed road and point of interest (POI) data, which includes highly detailed coastal roads and POIs such as restaurants, lodging, and local attractions.

**Auto Guidance:** Uses specified information about your vessel and chart data to determine the best path to your destination.

## Viewing Tide Station Information

 on a chart indicates a tide station. You can view a detailed graph for a tide station to help predict the tide level at different times or on different days.

**NOTE:** This feature is available with premium charts, in some areas.

- 1 From the Nav. chart or Fishing chart, select a tide station.  
Tide direction and tide level information appear near .
- 2 Select the station name.

## Animated Tide and Current Indicators

**NOTE:** This feature is available with premium charts, in some areas.

You can view indicators for animated tide station and current direction on the Nav. chart or the Fishing chart. You must also enable animated icons in the chart settings.

An indicator for a tide station appears on the chart as a vertical bar graph with an arrow. A red arrow pointing downward indicates a falling tide, and a blue arrow pointing upward indicates a rising tide. When you move the cursor over the tide station indicator, the height of the tide at the station appears above

the station indicator.

Current direction indicators appear as arrows on the chart. The direction of each arrow indicates the direction of the current at a specific location on the chart. The color of the current arrow indicates the range of speed for the current at that location. When you move the cursor over the current direction indicator, the specific current speed at the location appears above the direction indicator.

Color	Current Speed Range
Yellow	0 to 1 knot
Orange	1 to 2 knots
Red	2 or more knots

### Showing Tides and Current Indicators

**NOTE:** This feature is available with premium charts, in some areas.

You can show static or animated tide and current station indicators on the Nav. chart or Fishing chart.

- 1 From the Nav. or Fishing chart, select **MENU > Chart Setup > Tides & Currents**.
- 2 Select an option:
  - To show current station indicators and tide station indicators on the chart, select **On**.
  - To show animated tide station indicators and animated current direction indicators on the chart, select **Animated**.

### Selecting a Map

If your product has both BlueChart g2 and Garmin LakeVü™ HD built-in maps, you can select which map to use. Not all models have both types of built-in maps.

- 1 From the Nav. chart, select **MENU > Built-in Map**.

- 2 Select an option:

- When you are on an inland lake, select **LakeVü™ HD**.
- When you are offshore, select **BlueChart® g2**.



## Automatic Identification System





The Automatic Identification System (AIS) enables you to identify and track other vessels, and alerts you to area traffic. When connected to an external AIS device, AQUAMAP can show some AIS information about other vessels that are within range, that are equipped with a transponder, and that are actively transmitting AIS information.

The information reported for each vessel includes the Maritime Mobile Service Identity (MMSI), location, GPS speed, GPS heading, time that has elapsed since the last position of the vessel was reported, nearest approach, and time to the nearest approach.

Some AQUAMAP models also support Blue Force Tracking. Vessels being tracked with Blue Force Tracking are indicated with a blue-green color.

### AIS Targeting Symbols

Symbol	Description
	AIS vessel. The vessel is reporting AIS information. The direction in which the triangle is pointing indicates the direction in which the AIS vessel is moving.
	Target is selected.
	Target is activated. The target appears larger on the chart. A green line attached to the target indicates the heading of the target. The MMSI, speed, and direction of the vessel appear beneath the target, if the details setting has been set to Show. If the AIS transmission from the vessel is lost, a message banner appears.

	<p>Target is lost. A green X indicates that the AIS transmission from the vessel is lost, and the AQUAMAP displays a message banner asking whether the vessel should continue to be tracked. If you discontinue vessel tracking, the lost target symbol disappears from the chart or the 3D chart view.</p>
	<p>Dangerous target in range. The target flashes while an alarm sounds and a message banner appears. After the alarm has been acknowledged, a solid red triangle with a red line attached to it indicates the location and the heading of the target. If the safe-zone collision alarm has been set to Off, the target flashes, but the audible alarm does not sound and the alarm banner does not appear. If the AIS transmission from the vessel is lost, a message banner appears.</p>
	<p>Dangerous target is lost. A red X indicates that the AIS transmission from the vessel is lost, and the AQUAMAP displays a message banner asking whether the vessel should continue to be tracked. If you discontinue vessel tracking, the lost dangerous target symbol disappears from the chart or the 3D chart view.</p>
	<p>The location of this symbol indicates the closest point of approach to a dangerous target, and the numbers near the symbol indicate the time to the closest point of approach to that target.</p>

**NOTE:** Vessels being tracked with the Blue Force Tracking feature are indicated with a blue-green color regardless of their status.

## Heading and Projected Course of Activated AIS Targets

When heading and course over ground information are provided by an activated AIS target, the heading of the target appears on a chart as a solid line attached to the AIS target symbol. A heading line does not appear on a 3D chart view.

The projected course of an activated AIS target appears as a dashed line on a chart or a 3D chart view. The length of the projected course line is based on the value of the projected heading setting. If an activated AIS target is not transmitting speed information, or if the vessel is not moving, a projected

course line does not appear. Changes in the speed, course over ground, or rate of turn information transmitted by the vessel can impact the calculation of the projected course line.

When course over ground, heading, and rate of turn information are provided by an activated AIS target, the projected course of the target is calculated based on the course over ground and the rate of turn information. The direction in which the target is turning, which is also based on the rate of turn information, is indicated by the direction of the barb at the end of the heading line. The length of the barb does not change.



When course over ground and heading information are provided by an activated AIS target, but rate of turn information is not provided, the projected course of the target is calculated based on the course over ground information.

## Showing AIS and MARPA Vessels

Before you can show AIS vessels on a chart, you must have an external AIS device and active transponder signals from other vessels. Mini Automatic Radar Plotting Aid (MARPA) functionality works with radar.

You can configure how other vessels appear on a chart or on a 3D chart view. The display range and MARPA settings configured for one chart or one 3D chart view are applied only to that chart or to that 3D chart view. The details, projected heading, and trails settings configured for one chart or one 3D chart view are applied to all charts and to all 3D chart views.

- 1 From a chart or a 3D chart view, select **MENU > Other Vessels > Display Setup**.
- 2 Select an option:
  - To indicate the distance from your location in which AIS vessels appear, select **Display Range**, and select a distance.

- To show MARPA-tagged vessels, select **MARPA > Show**.
- To show details about AIS-activated and MARPA- tagged vessels, select **MARPA > Show**.
- To set the projected heading time for AIS-activated and MARPA-tagged vessels, select **Proj. Heading**, and enter the time.
- To show the tracks of AIS vessels, and the length of the track using a trail, select **Trails**, and select the length.

### Activating a Target for an AIS Vessel

- 1 From a chart or a 3D chart view, select an AIS vessel.
- 2 Select **AIS Vessel > Activate Target**.

### Viewing Information about a Targeted AIS Vessel

You can view the AIS signal status, MMSI, GPS speed, GPS heading, and other information that is reported about a targeted AIS vessel.

- 1 From a chart or a 3D chart view, select an AIS vessel.
- 2 Select **AIS Vessel**.

### Deactivating a Target for an AIS Vessel

- 1 From a chart or a 3D chart view, select an AIS vessel.
- 2 Select **AIS Vessel > Deactivate**.

### Viewing a List of AIS and MARPA Threats

- 1 From a chart or a 3D chart view, select **MENU > Other Vessels > List > Show**.
- 2 Select the type of threats to include in the list.

### AIS Distress Signals

Self-contained AIS distress signal devices transmit emergency position reports when activated. The AQUAMAP can receive signals from Search and

Rescue Transmitters (SART), Emergency Position Indicating Radio Beacons (EPIRB), and other man overboard signals.





Distress signal transmissions are different than standard AIS transmissions, so they appear differently on the AQUAMAP. Instead of tracking a distress signal transmission for collision avoidance, you track a distress signal transmission to locate and assist a vessel or person.

### Navigating to a Distress Signal Transmission

When you receive a distress signal transmission, a distress signal alarm appears.

Select **Review > Go To** to begin navigation to the transmission.

### AIS Distress Signal Device Targeting Symbols

Symbol	Description
	AIS distress signal device transmission. Select to see more information about the transmission and begin navigation.
	Transmission lost.
	Transmission test. Appears when a vessel initiates a test of their distress signal device, and does not represent a true emergency.
	Transmission test lost.

### Enabling AIS Transmission Test Alerts

To avoid a large number of test alerts and symbols in crowded areas such as marinas, you can select to receive or ignore AIS test messages. To test an AIS emergency device, you must enable the AQUAMAP to receive test alerts.

- 1 Select **Settings > Alarms > AIS**.
- 2 Select an option:
  - To receive or ignore Emergency Position Indicating Radio Beacon (EPRIB) test signals, select **AIS- EPIRB Test**.

- To receive or ignore Man Overboard (MOB) test signals, select **AIS-MOB Test**.
- To receive or ignore Search and Rescue Transponder (SART) test signals, select **AIS-SART Test**.

## Turning Off AIS Reception

AIS signal reception is turned on by default.

Select **Settings > Other Vessels > AIS > Off**.

All AIS functionality on all charts and 3D chart views is disabled. This includes AIS vessel targeting and tracking, collision alarms that result from AIS vessel targeting and tracking, and the display of information about AIS vessels.

## Chart and 3D Chart View Settings

**NOTE:** Not all settings apply to all charts and 3D chart views. Some options require premium maps or connected accessories, such as radar.

These settings apply to the charts and 3D chart views, except the radar overlay and Fish Eye 3D.

From a chart or a 3D chart view, press MENU, and select an option:

**Marks, Wpts & Tracks:** Opens waypoint and tracks lists.

**Other Vessels:** Adjusts how other vessels are shown.

**Surface Radar:** Shows surface radar details on the Perspective 3D or Mariner's Eye 3D chart views.

**Weather Radar:** Shows weather radar imaging on the Perspective 3D or Mariner's Eye 3D chart views.

**Nav aids:** Shows navigational aids on the Fishing chart.

**Quickdraw Contours:** Turns on bottom contour drawing, and allows you to create fishing map labels.

**Chart Setup:** Adjusts the components to appear on the charts.

**Chart Appearance:** Adjusts the appearance of the different charts and 3D chart views. This may appear in the Chart Setup menu.

**Edit Overlays:** Adjusts the data shown on the screen. This may appear in the Chart Setup menu.

## Marks, Wpts & Tracks Settings on the Charts and Chart Views

From a chart or a 3D chart view, select **MENU > Marks, Wpts & Tracks**.

**Tracks:** Shows tracks on the chart or 3D chart view.

**Marks & Waypoints:** Shows the list of waypoints.

**New Waypoint:** Creates a new waypoint.

**Waypoint Display:** Sets how to display waypoints on the chart.

**Active Tracks:** Shows the active track options menu.

**Saved Tracks:** Shows the list of saved tracks.

**Tracks Display:** Sets which tracks to display on the chart based on track color.

**Routes & Auto Guidance:** Shows routes and guidance on the chart.

## Other Vessels Settings on the Charts and Chart Views

**NOTE:** These options require connected accessories, such as an AIS receiver or VHF radio.

From a chart or a 3D chart view, select **MENU > Other Vessels**.

**List:** Shows a list of AIS and MARPA vessels.

**AIS Group:** Manages AIS groups.

**DSC:** Shows the DSC list and sets the DSC trails on the chart.

**Collision Alarm:** Sets the safe-zone collision alarm.

**Display Setup:** Sets how AIS and MARPA vessels are displayed.

## Navigation and Fishing Chart Setup

**NOTE:** Not all settings apply to all charts and 3D chart views. Some settings

require external accessories or applicable premium charts.

From the Nav. chart or Fishing chart, select **MENU > Chart Setup**.

**Photos:** Shows high-resolution satellite images on the land or on both land and sea portions of the Nav. chart, when certain premium maps are used.

**Water Overlay:** Enables relief shading, which shows the gradient of the bottom with shading, or sonar imagery, which helps identify the density of the bottom. This feature is available only with some premium maps.

**Custom Maps:** Shows custom maps on the chart or 3D chart view. You can view KMZ files exported from Google Maps or Google Earth.

**Tides & Currents:** Shows current station indicators and tide station indicators on the chart and enables the tides and current slider, which sets the time for which tides and currents are reported on the map.

**Roses:** Shows a compass rose around your boat, indicating compass direction oriented to the heading of the boat. A true wind direction or apparent wind direction indicator appears if the AQUAMAP is connected to a compatible marine wind sensor.

**Lake Level:** Sets the present water level of the lake. This feature is available only with some premium maps.

**Inset Map:** Shows a small map centered on your present location.

**Weather:** Sets which weather items are shown on the chart, when the AQUAMAP is connected to a compatible weather receiver with an active subscription. Requires a compatible, connected antenna and an active subscription.

**Chart Appearance:** Sets the appearance of the different charts views.

## Chart Appearance Settings

You can adjust the appearance of the different charts and 3D chart views. Each setting is specific to the chart or chart view being used.

**NOTE:** Not all settings apply to all charts and 3D chart views and AQUAMAP models. Some options require premium maps or connected accessories.

From a chart or 3D chart view, select **MENU > Chart Appearance** or **MENU > Chart Setup > Chart Appearance**.

**Orientation:** Sets the perspective of the map.

**Detail:** Adjusts the amount of detail shown on the map, at different zoom levels.

**Heading Line:** Shows and adjusts the heading line, which is a line drawn on the map from the bow of the boat in the direction of travel, and sets the data source for the heading line.

**Panoptix Area:** Shows and hides the area being scanned by the Panoptix™ transducer. The attitude and heading reference system (AHRS) must be calibrated use this feature.

**World Map:** Uses either a basic world map or a shaded relief map on the chart. These differences are visible only when zoomed out too far to see the detailed charts.

**Shallow Shading:** Sets the shades from the shoreline to the specified depth.

**Depth Shading:** Specifies an upper and lower depth to shade between.

**Spot Depths:** Turns on spot soundings and sets a dangerous depth. Spot depths that are equal to or more shallow than the dangerous depth are indicated by red text.

**Symbols:** Shows and configures the appearance of various symbols on the chart, such as the vessel icon, navaid symbols, land POIs, and light sectors.

**Inset Map:** Shows a map zoomed in on the vessel's location in the corner of the main map.

**Style:** Sets how the chart appears over 3D terrain.

**Hazard Colors:** Shows shallow water and land with a color scale. Blue indicates deep water, yellow is shallow water, and red is very shallow water.

**Preferred Depth:** Sets the appearance of a safe depth for the Mariner's Eye 3D chart view.

**NOTE:** This setting affects only the appearance of hazard colors for the Mariner's Eye 3D chart view. It does not affect the safe water depth Auto Guidance setting or the sonar shallow water alarm setting.

**Range Rings:** Shows and configures the appearance of range rings, which help you to visualize distances in some chart views.

**Lane Width:** Specifies the width of the navigation lane, which is the magenta line in some chart views that indicates the course to your destination.

## Laylines Settings

To use the laylines features, you must connect a wind sensor to the AQUAMAP.

When in sailing mode, you can display laylines on the Nav. chart. Laylines can be very helpful when racing.

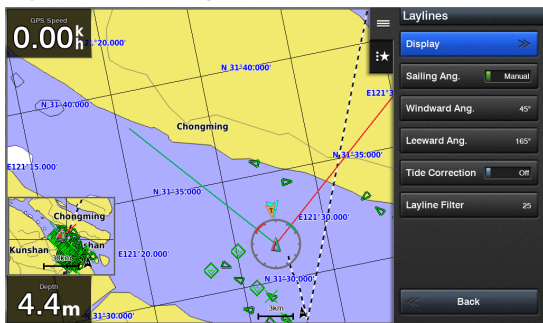

From the Nav. chart, select **MENU > Sailing > Laylines**.

**Display:** Sets how the laylines and vessel appear on the chart, and sets the length of the laylines.

**Sailing Ang.:** Allows you to select how the device calculates laylines. The Actual option calculates the laylines using the measured wind angle from the wind sensor. The Manual option calculates the laylines using manually entered windward and leeward angles.

**Windward Ang.:** Allows you to set a layline based on the windward sailing angle.

**Leeward Ang.:** Allows you to set a layline based on the leeward sailing angle.

**Tide Correction:** Corrects the laylines based on the tide.

**Layline Filter:** Filters the layline data based on the time interval entered.

For a smoother layline that filters out some of the changes in the boat's heading or true wind angle, enter a higher number. For laylines that display a higher sensitivity to changes in the boat's heading or true wind angle, enter a lower number.

## Fish Eye 3D Settings

**NOTE:** This feature is available with premium charts, in some areas.

From the Fish Eye 3D chart view, select **MENU**.

**View:** Sets the perspective of the 3D chart view.

**Tracks:** Shows tracks.

**Sonar Cone:** Shows a cone that indicates the area covered by the transducer.

**Fish Symbols:** Shows suspended targets.

## Garmin Quickdraw Contours Mapping



The Garmin Quickdraw Contours mapping feature allows users to generate maps. Garmin makes no representations about the accuracy, reliability, completeness or timeliness of the maps generated by third parties. Any use or reliance on the maps generated by third parties is at your own risk.

The Garmin Quickdraw Contours mapping feature allows you to instantly create maps with contours and depth labels for any body of water.

When Garmin Quickdraw Contours records data, a colored circle surrounds

the vessel icon. This circle represents the approximate area of the map that is scanned by each pass.



A green circle indicates good depth and GPS position, and a speed under 16 km/h (10 mph). A yellow circle indicates good depth and GPS position, and a speed between 16 and 32 km/h (10 and 20 mph). A red circle indicates poor depth or GPS position, and a speed above 32 km/h (20 mph).

You can view Garmin Quickdraw Contours in a combination screen or as a single view on the map.

The amount of saved data depends on the size of your memory card, your sonar source, and the speed of your boat as you record data. You can record longer when you use a single-beam sonar. It is estimated that you might be able to record about 1,500 hours of data onto a 2 GB memory card.

When you record data on a memory card in your AQUAMAP, the new data is added to your existing Garmin Quickdraw Contours map, and is saved on the memory card. When you insert a new memory card, the existing data does not transfer onto the new card.

## Mapping a Body of Water Using the Garmin Quickdraw Contours

Before you can use the Garmin Quickdraw Contours feature, you must have a supported AQUAMAP with upgraded software, sonar depth, your GPS position, and a memory card with free space.



**NOTE:** This feature is not available on all models.

- 1 From a chart view, select **MENU > Quickdraw Contours > Start Recording**.
- 2 When recording is complete, select **Stop Recording**.
- 3 Select **Manage > Name**, and enter a name for the map.

## Adding a Label to a Garmin Quickdraw Contours Map

You can add labels to a Garmin Quickdraw Contours map to mark hazards or points of interest.

- 1 From the Nav. chart, select a location.
- 2 Select **Add Quickdraw Label**.
- 3 Enter text for the label, and select **Done**.

## Garmin Quickdraw Community

The Garmin Quickdraw Community is a free, public, online community that enables you to share your Garmin Quickdraw Contours maps with others. You can also download maps other users have created.

To access the Garmin Quickdraw Community, sign in to your Garmin Connect™ account, and then you can upload and download maps using a

memory card.

### ***Accessing the Garmin Quickdraw Community***

You can access the Garmin Quickdraw Community using Garmin Connect website.

- 1 Go to [connect.garmin.com](https://connect.garmin.com).
- 2 Select **Get Started > Quickdraw Community > Get Started**.
- 3 If you do not have a Garmin Connect account, create one.
- 4 Sign in to your Garmin Connect account.
- 5 Select **Marine** in the upper-right to open the Garmin Quickdraw widget.

**TIP:** Make sure you have a memory card in your computer to share Garmin Quickdraw Contours maps.

### ***Sharing Your Garmin Quickdraw Contours Maps with the Garmin Quickdraw Community***

You can share Garmin Quickdraw Contours maps that you have created with others in the Garmin Quickdraw Community.

When you share a contour map, only the contour map is shared. Your waypoints are not shared.

- 1 Remove the memory card from the AQUAMAP.
- 2 Insert the memory card into your computer.
- 3 Access the Garmin Quickdraw Community.
- 4 Select **Share Your Contours**.
- 5 Browse to your memory card, and select the /Garmin folder.
- 6 Open the Quickdraw folder, and select the file named ContoursLog.svy.

After the file is uploaded, delete the ContoursLog.svy file from your memory card to avoid issues with future uploads. Your data will not be lost.

### ***Downloading Garmin Quickdraw Community Maps***

You can download Garmin Quickdraw Contours maps that other users have created and shared with the Garmin Quickdraw Community.

- 1 Insert the memory card into your computer.
- 2 Access the Garmin Quickdraw Community.
- 3 Select **Search for Contours**.
- 4 Use the map and search features to locate an area to download.  
The red dots represent Garmin Quickdraw Contours maps that have been shared for that region.
- 5 Select **Select an Area to Download**.
- 6 Drag the edges of the box to select the area to download.
- 7 Select **Start Download**.
- 8 Save the file to your memory card.  
**TIP:** If you cannot find the file, look in the "Downloads" folder. The browser may have saved the file there.
- 9 Remove the memory card from your computer.
- 10 Insert the memory card in the AQUAMAP.

The AQUAMAP automatically recognizes the contours maps. The AQUAMAP may take a few minutes to load the maps.

## Garmin Quickdraw Contours Settings

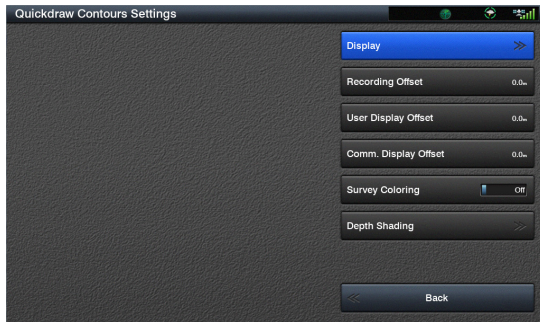

From a chart, select **MENU > Quickdraw Contours > Settings**.

**Display:** Displays Garmin Quickdraw Contours. The User Contours option shows your own Garmin Quickdraw Contours maps. The Community Contours option shows the maps you have downloaded from the Garmin Quickdraw Community.

**Recording Offset:** Sets the distance between the sonar depth and the contour recording depth. If the water level has changed since your last recording, adjust this setting so the recording depth is the same for both recordings.

For example, if the last time you recorded had a sonar depth of 3.1 m (10.5 ft.), and today's sonar depth is 3.6 m (12 ft.), enter -0.5 m (-1.5 ft.) for the a Recording Offset value.

**User Display Offset:** Sets differences in contour depths and depth labels on your own contours maps to compensate for changes in the water level of a body of water, or for depth errors in recorded maps.

**Comm. Display Offset:** Sets differences in contour depths and depth labels on the community contours maps to compensate for changes in the water level of a body of water, or for depth errors in recorded maps.

**Survey Coloring:** Sets the color of the Garmin Quickdraw Contours display.

When this setting is turned on, the colors indicate the quality of the recording. When this setting is turned off, the contour areas use standard map colors.

Green indicates good depth and GPS position, and a speed under 16 km/h (10 mph). Yellow indicates good depth and GPS position, and a speed between 16 and 32 km/h (10 and 20 mph). Red indicates poor depth or GPS position, and a speed above 32 km/h (20 mph).

**Depth Shading:** Specifies the upper and lower limits of a depth range and a color for that depth range.

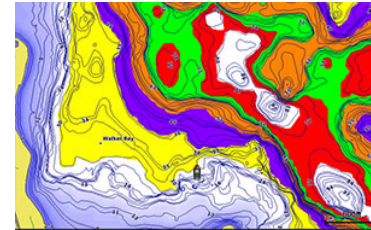

# Navigation with AQUAMAP

## ⚠ CAUTION

If your vessel has an autopilot system, a dedicated autopilot control display must be installed at each steering helm in order to disable the autopilot system.

The Auto Guidance feature is based on electronic chart information. That data does not ensure obstacle and bottom clearance. Carefully compare the course to all visual sightings, and avoid any land, shallow water, or other obstacles that may be in your path.

When using Go To, a direct course and a corrected course may pass over land or shallow water. Use visual sightings, and steer to avoid land, shallow water, and other dangerous objects.

**NOTE:** Some chart views are available with premium charts, in some areas.

To navigate, you must choose a destination, set a course or create a route, and follow the course or route. You can follow the course or the route on the Nav. chart, Fishing chart, or 3D chart view.

You can set and follow a course to a destination using one of three methods:

**Go To:** Takes you directly to the destination. This is the standard option for navigating to a destination. The AQUAMAP creates a straight-line course or navigation line to the destination. The path may run over land and other obstacles.

**Route To:** Creates a route from your location to a destination, allowing you to add turns along the way. This option provides a straight-line course to the destination, but allows you to add turns into the route to avoid land and other obstacles.

**Auto Guidance:** Uses the specified information about your vessel and chart data to determine the best path to your destination. This option is available only when using a compatible premium chart in a compatible AQUAMAP. It provides a turn-by-turn navigation path to the destination, avoiding land

and other obstacles.

When you are using a compatible Garmin autopilot connected to the AQUAMAP using NMEA 2000®, the autopilot follows the Auto Guidance route.

**NOTE:** Auto Guidance is available with premium charts, in some areas.

## Basic Navigation Questions

Question	Answer
How do I make the device guide me to a location while avoiding charted obstacles?	Build a multi-leg route and navigate it using Route To.
How do I make the device steer my automatic pilot?	Navigate using Route To.
Can the device create a path for me?	If you have premium maps that support Auto Guidance and are in an area covered by Auto Guidance, navigate using Auto Guidance.

## Destinations

You can select destinations using various charts and 3D chart views or using the lists.

### Searching for a Destination by Name

You can search for saved waypoints, saved routes, saved tracks, and marine services destinations by name.

- 1 Select **NAV INFO > Services > Search by Name**.
- 2 Enter at least a portion of the name of your destination.
- 3 If necessary, select **Done**.

The 50 nearest destinations that contain your search criteria appear.

- 4 Select the destination.

## Selecting a Destination Using the Nav. chart

From the Nav. chart, select a destination.

## Searching for a Marine Services Destination

**NOTE:** This feature is available with premium charts, in some areas.

The AQUAMAP contains information for thousands of destinations offering marine services.

- 1 Select **NAV INFO > Services**.
- 2 Select **Offshore Services** or **Inland Services**.
- 3 If necessary, select the marine service category. The AQUAMAP shows a list of the nearest locations and the distance and bearing to each.
- 4 Select a destination. You can select **Next Page** or **Previous Page** to view additional information or to show the location on a chart.

## Stopping Navigation

While navigating, from the Nav. chart or Fishing chart, select an option:

- Select **MENU > Stop Navigation**.
- When navigating with Auto Guidance, select **MENU > Navigation Options > Stop Navigation**.

## Marks and Waypoints

Waypoints are locations you record and store in the device.

### Marking Your Current Location as a Waypoint

From any screen, press **MARK WPT MOB**.

### Creating a Waypoint at a Different Location

- 1 From a Nav. chart or 3D chart view, select **MENU > Marks, Wpts &**

### Tracks > Marks & Waypoints.

**NOTE:** The Marks & Waypoints menu can also be accessed from any screen by selecting **NAV INFO > User Data > Marks & Waypoints**.

- 2 Select **New Waypoint** and select an option:
  - To create the waypoint by entering position coordinates, select **Enter Coordinates**, and enter the coordinates.
  - To create the waypoint using a chart, select **Use Chart**, select the location, and press **SELECT**.

### Creating a Waypoint on the Sonar Screen

- 1 From a sonar view, use the arrow keys to select a location.
- 2 Press **SELECT**.
- 3 If necessary, edit the waypoint information.

### Creating a Waypoint on the Chart

- 1 From a chart or a 3D chart view, select a location or object.
- 2 Select **Create Waypoint** or press **MARK WPT MOB**.

### Marking an SOS Location

You can mark an SOS location. When a Garmin VHF radio is connected using NMEA 2000, you can select different SOS types, such as Man-Overboard and Piracy.

- 1 Hold **MARK WPT MOB** for one second.
- 2 Select the SOS type.
- 3 If necessary, select **OK** to navigate to the man overboard location.

If you selected OK, the AQUAMAP sets a direct course back to the location. If you selected another type of SOS, the call details are sent to the VHF radio. You must send the call using the radio.

## Viewing a List of all Waypoints

From a Nav. chart or 3D chart view, select **MENU > Marks, Wpts & Tracks > Marks & Waypoints**.

## Editing a Saved Waypoint

- 1 From a Nav. chart or 3D chart view, select **MENU > Marks, Wpts & Tracks > Marks & Waypoints**.
- 2 Select a waypoint.
- 3 Select **Review > Edit**.
- 4 Select an option:
  - To add a name, select **Name**, and enter a name.
  - To change the symbol, select **Symbol**.
  - To change the depth, select **Depth**.
  - To change the water temperature, select **Water Temp.**
  - To change the comment, select **Comment**.

## Moving a Saved Waypoint

- 1 From a Nav. chart or 3D chart view, select **MENU > Marks, Wpts & Tracks > Marks & Waypoints**.
- 2 Select a waypoint.
- 3 Select **Review > Position**.
- 4 Indicate a new location for the waypoint:
  - To move the waypoint while using the chart, select **Use Chart**, select a new location on the chart, and select **Move Waypoint**.
  - To move the waypoint using coordinates, select **Enter Coordinates**, and enter the new coordinates.

## Browsing for and Navigating to a Saved Waypoint

### CAUTION

The Auto Guidance feature is based on electronic chart information. That data does not ensure obstacle and bottom clearance. Carefully compare the course to all visual sightings, and avoid any land, shallow water, or other obstacles that may be in your path.

When using Go To, a direct course and a corrected course may pass over land or shallow water. Use visual sightings, and steer to avoid land, shallow water, and other dangerous objects.

**NOTE:** Auto Guidance is available with premium charts, in some areas.

Before you can navigate to a waypoint, you must create a waypoint.

- 1 From a Nav. chart or 3D chart view, select **MENU > Marks, Wpts & Tracks > Marks & Waypoints**.
- 2 Select a waypoint.
- 3 Select **Navigate To**.
- 4 Select an option:
  - To use Auto Guidance, select **Auto Guidance**.
  - To navigate directly to the location, select **Go To**.
  - To create a route to the location, including turns, select **Route To**.
- 5 Review the course indicated by the magenta line.

**NOTE:** When using Auto Guidance, a gray segment within any part of the magenta line indicates that Auto Guidance cannot calculate part of the Auto Guidance line. This is due to the settings for minimum safe water depth and minimum safe obstacle height.
- 6 Follow the magenta line, steering to avoid land, shallow water, and other obstacles.

## Deleting a Waypoint or an MOB

- 1 From a Nav. chart or 3D chart view, select **MENU > Marks, Wpts & Tracks > Marks & Waypoints**.
- 2 Select a waypoint or an MOB.
- 3 Select **Review > Delete**.

## Deleting All Waypoints

Select **NAV INFO > User Data > Clear User Data > Marks & Waypoints > All**.

## Setting and Following a Direct Course Using Go To



When using Go To, a direct course and a corrected course may pass over land or shallow water. Use visual sightings, and steer to avoid land, shallow water, and other dangerous objects.

You can set and follow a direct course from your current location to a selected destination.

- 1 Select a destination.
- 2 Select **Navigate To > Go To**.

A magenta line appears. In the center of the magenta line is a thinner purple line that represents the corrected course from your current location to the destination. The corrected course is dynamic, and it moves with your boat when you are off course.

- 3 Follow the magenta line, steering to avoid land, shallow water, and other obstacles.
- 4 If you are off course, follow the purple line (corrected course) to go to your destination, or steer back to the magenta line (direct course).

## Tracks

A track is a recording of the path of your boat. The track currently being recorded is called the active track, and it can be saved. You can show tracks in each chart or 3D chart view.

### Recording Tracks

From a chart or a 3D chart view, select **MENU > Marks, Wpts & Tracks > Tracks > On**.

A trailing line on the chart indicates your track.

### Managing the Track Log Memory During Recording

- 1 From a chart or a 3D chart view, select **MENU > Marks, Wpts & Tracks > Active Tracks > Active Track Options > Record Mode**.

**NOTE:** The Tracks menu can also be accessed from any screen by selecting **NAV INFO > User Data > Tracks**.

- 2 Select an option:
  - To record a track log until the track memory is full, select **Fill**.
  - To continuously record a track log, replacing the oldest track data with new data, select **Wrap**.

### Configuring the Recording Interval of the Track Log

You can indicate the frequency at which the track plot is recorded. Recording more frequent plots is more accurate but fills the track log faster. The resolution interval is recommended for the most efficient use of memory.

- 1 From a chart or a 3D chart view, select **MENU > Marks, Wpts & Tracks > Active Tracks > Active Track Options**.
- 2 Select an option:
  - To record the track based on a distance between points, select **Distance > Change**, and enter the distance.
  - To record the track based on a time interval, select **Time > Change**,

and enter the time interval.

- To record the track plot based on a variance from your course, select **Resolution > Change**, and enter the maximum error allowed from the true course before recording a track point. This is the recommended recording option.

## Setting the Color of the Active Track

- 1 From a chart or a 3D chart view, select **MENU > Marks, Wpts & Tracks > Active Tracks > Active Track Options > Track Color**.
- 2 Select a track color.

## Saving the Active Track

The track currently being recorded is called the active track.

- 1 From a chart or a 3D chart view, select **MENU > Marks, Wpts & Tracks > Active Tracks > Save Active Track**.
- 2 Select an option:
  - Select the time the active track began.
  - Select **Entire Log**.
- 3 Select **Save**.

## Clearing the Active Track

From a chart or a 3D chart view, select **MENU > Marks, Wpts & Tracks > Active Tracks > Clear Active Track**.

The track memory is cleared, and the active track continues to be recorded.

## Retracing the Active Track

The track currently being recorded is called the active track.

- 1 From a chart or a 3D chart view, select **MENU > Marks, Wpts & Tracks > Active Tracks > Follow Active Track**.

- 2 Select an option:
  - Select the time the active track began.
  - Select **Entire Log**.
- 3 Review the course indicated by the colored line.
- 4 Follow the colored line, steering to avoid land, shallow water, and other obstacles.

## Viewing a List of Saved Tracks

From a chart or a 3D chart view, select **MENU > Marks, Wpts & Tracks > Saved Tracks**.

## Editing a Saved Track

- 1 From a chart or a 3D chart view, select **MENU > Marks, Wpts & Tracks > Saved Tracks**.
- 2 Select a track.
- 3 Select **Edit Track**.
- 4 Select an option:
  - Select **Name**, and enter the new name.
  - Select **Track Color**, and select a color.

## Saving a Track as a Route

- 1 From a chart or a 3D chart view, select **MENU > Marks, Wpts & Tracks > Saved Tracks**.
- 2 Select a track.
- 3 Select **SELECT > Edit Track > Save Route**.

## Browsing for and Navigating a Recorded Track

Before you can browse a list of tracks and navigate to them, you must record and save at least one track.

- 1 From a chart or a 3D chart view, select **MENU > Marks, Wpts & Tracks > Saved Tracks**.
- 2 Select a track.
- 3 Select **Follow Track**.
- 4 Select an option:
  - To navigate the track from the starting point used when the track was created, select **Forward**.
  - To navigate the track from the destination point used when the track was created, select **Backward**.
- 5 Review the course indicated by the colored line.
- 6 Follow the line along each leg in the route, steering to avoid land, shallow water, and other obstacles.

### Deleting a Saved Track

- 1 From a chart or a 3D chart view, select **MENU > Marks, Wpts & Tracks > Saved Tracks**.
- 2 Select a track.
- 3 Select **SELECT > Delete**.

### Deleting All Saved Tracks

Select **NAV INFO > User Data > Clear User Data > Saved Tracks**.

## Routes

### Creating and Navigating a Route from Your Present Location

You can create and immediately navigate a route on the Nav. chart or the Fishing chart. This procedure does not save the route or the waypoint data.

**NOTE:** The offshore Fishing chart is available with premium charts, in some areas.

- 1 From the Nav. chart or Fishing chart, select a destination.

- 2 Select **SELECT > Navigate To > Route To**.
- 3 Select the location of the last turn before the destination.
- 4 Select **SELECT > Add Turn**.
- 5 If necessary, repeat step 3 and 4 to add additional turns, working backward from the destination to the present location of your vessel.  
The last turn you add should be the first turn you make, starting from your present location. It should be the turn closest to your vessel.
- 6 Select **SELECT > Done**.
- 7 Review the course indicated by the magenta line.
- 8 Follow the magenta line, steering to avoid land, shallow water, and other obstacles.

### Creating and Saving a Route

This procedure saves the route and all the waypoints in it. The starting point can be your present location or another location.

- 1 Select **NAV INFO > User Data > Routes & Auto Guidance > New > Route Using Chart**.
- 2 Select the starting location of the route.
- 3 Select **SELECT > Add Turn**.
- 4 Select the location of the next turn on the chart.
- 5 Select **SELECT > Add Turn**.  
The AQUAMAP marks the location of the turn with a waypoint.
- 6 If necessary, repeat steps 4 and 5 to add more turns.
- 7 Select **SELECT > Done**.

### Viewing a List of Routes and Auto Guidance Paths

- 1 Select **NAV INFO > User Data > Routes & Auto Guidance**.
- 2 If necessary, select **Filter** to see routes only or Auto Guidance paths only.

## Editing a Saved Route

You can change the name of a route or change the turns the route contains.

- 1 Select **NAV INFO > User Data > Routes & Auto Guidance**.
- 2 Select a route.
- 3 Select **Review > Edit Route**.
- 4 Select an option:
  - To change the name, select **Name**, and enter the name.
  - To select a waypoint from the turn list, select **Edit Turns > Use Turn List**, and select a waypoint from the list.
  - To select a turn using the chart, select **Edit Turns > Use Chart**, and select a location on the chart.

## Browsing for and Navigating a Saved Route

Before you can browse a list of routes and navigate to one of them, you must create and save at least one route.

- 1 Select **NAV INFO > User Data > Routes & Auto Guidance**.
- 2 Select a route.
- 3 Select **Navigate To**.
- 4 Select an option:
  - To navigate the route from the starting point used when the route was created, select **Forward**.
  - To navigate the route from the destination point used when the route was created, select **Backward**.

A magenta line appears. In the center of the magenta line is a thinner purple line that represents the corrected course from your present location to the destination. The corrected course is dynamic, and it moves with your boat when you are off course.

- 5 Review the course indicated by the magenta line.

- 6 Follow the magenta line along each leg in the route, steering to avoid land, shallow water, and other obstacles.
- 7 If you are off course, follow the purple line (corrected course) to go to your destination, or steer back to the magenta line (direct course).

## Browsing for and Navigating Parallel to a Saved Route

Before you can browse a list of routes and navigate to one of them, you must create and save at least one route.

- 1 Select **NAV INFO > User Data > Routes & Auto Guidance**.
- 2 Select a route.
- 3 Select **Navigate To**.
- 4 Select **Offset** to navigate parallel to the route, offset from it by a specific distance.
- 5 Indicate how to navigate the route:
  - To navigate the route from the starting point used when the route was created, to the left of the original route, select **Forward - Port**.
  - To navigate the route from the starting point used when the route was created, to the right of the original route, select **Forward - Starboard**.
  - To navigate the route from the destination point used when the route was created, to the left of the original route, select **Backward - Port**.
  - To navigate the route from the destination point used when the route was created, to the right of the original route, select **Backward - Starboard**.
- 6 If necessary, select **Done**.

A magenta line appears. In the center of the magenta line is a thinner purple line that represents the corrected course from your present location to the destination. The corrected course is dynamic, and it moves with your boat when you are off course.

- 7 Review the course indicated by the magenta line.

- Follow the magenta line along each leg in the route, steering to avoid land, shallow water, and other obstacles.
- If you are off course, follow the purple line (corrected course) to go to your destination, or steer back to the magenta line (direct course).

### Deleting a Saved Route

- Select **NAV INFO > User Data > Routes & Auto Guidance**.
- Select a route.
- Select **Review > Delete**.

### Deleting All Saved Routes

Select **NAV INFO > User Data > Clear User Data > Routes & Auto Guidance**.

## Auto Guidance



The Auto Guidance feature is based on electronic chart information. That data does not ensure obstacle and bottom clearance. Carefully compare the course to all visual sightings, and avoid any land, shallow water, or other obstacles that may be in your path.

**NOTE:** Auto Guidance is available with premium charts, in some areas.

You can use Auto Guidance to plot the best path to your destination. Auto Guidance uses your AQUAMAP to scan chart data, such as water depth and known obstacles, to calculate a suggested path. You can adjust the path during navigation.

### Setting and Following an Auto Guidance Path

- Select a destination.
- Select **Navigate To > Auto Guidance**.
- Review the path, indicated by the magenta line.

- Select **Start Navigation**.
- Follow the magenta line, steering to avoid land, shallow water, and other obstacles.

**NOTE:** When using Auto Guidance, a gray segment within any part of the magenta line indicates that Auto Guidance cannot calculate part of the Auto Guidance line. This is due to the settings for minimum safe water depth and minimum safe obstacle height.

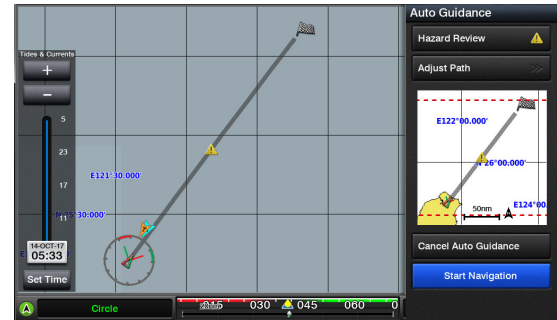

### Creating and Saving an Auto Guidance Path

- Select **NAV INFO > User Data > Routes & Auto Guidance > New > Auto Guidance**.
- Select a starting point, and select **Next**.
- Select a destination, and select **Next**.
- Select an option:
  - To view a hazard and adjust the path near a hazard, select **Hazard Review**.
  - To adjust the path, select **Adjust Path**, and follow the on-screen instructions.
  - To delete the path, select **Cancel Auto Guidance**.

- To save the path, select **Done**.

## Adjusting a Saved Auto Guidance Path

1 Select **NAV INFO > User Data > Routes & Auto Guidance**.

2 Select a path, and select **Review > Edit > Adjust Path**.

**TIP:** When navigating an Auto Guidance path, select the path on the Nav. chart, and select Adjust Path.

3 Select a location on the path.

4 Use the arrow keys to select a new location, and select **Remove**.

5 Select **Done**.

## Canceling an Auto Guidance Calculation in Progress

From the Nav. chart, select **MENU > Cancel**.

**TIP:** You can select BACK to quickly cancel the calculation.

## Setting a Timed Arrival

You can use this feature on a route or an Auto Guidance path to get feedback about when you should arrive at a selected point. This allows you to time your arrival at a location, such as a bridge opening or a race starting line.

1 From the Nav. chart, press **MENU**.

2 If necessary, select **Navigation Options**.

3 Select **Timed Arrival**.

**TIP:** You can quickly open the Timed Arrival menu by selecting a point on the path or route.

## Auto Guidance Path Configurations



The Preferred Depth and Vertical Clearance settings influence how the AQUAMAP calculates an Auto Guidance path. If an area has an unknown

water depth or an unknown obstacle height, the Auto Guidance path is not calculated in that area. If an area at the beginning or the end of an Auto Guidance path is shallower than the Preferred Depth or lower than the Vertical Clearance settings, the Auto Guidance path may not be calculated in that area, depending on the map data. On the chart, the course through those areas appears as a gray line or a magenta and gray striped line. When your boat enters one of those areas, a warning message appears.

**NOTE:** Auto Guidance is available with premium charts, in some areas.

**NOTE:** Not all settings apply to all maps.

You can set the parameters the AQUAMAP uses when calculating an Auto Guidance path.

**Preferred Depth:** Sets the minimum water depth, based on chart depth data, that your boat can safely travel over.

Select **Settings > Preferences > Navigation > Auto Guidance > Preferred Depth** and select a depth.

**NOTE:** The minimum water depth for the premium charts (made before 2016) is 3 feet. If you enter a value of less than 3 feet, the charts only use depths of 3 feet for Auto Guidance path calculations.

**Vertical Clearance:** Sets the minimum height of a bridge or obstacle, based on chart data, that your boat can safely travel under.

Select **Settings > Preferences > Navigation > Auto Guidance > Vertical Clearance** and enter a height.

**Shoreline Distance:** Sets how close to the shore you want the Auto Guidance path to be placed. The Auto Guidance path may move if you change this setting while navigating. The available values for this setting are relative, not absolute. To ensure that the Auto Guidance line is placed the appropriate distance from shore, you can assess the placement of the Auto Guidance path using one or more familiar destinations that require navigation through a narrow waterway.

## Adjusting the Distance from Shore

The Shoreline Distance setting indicates how close to the shore you want the Auto Guidance line to be placed. The Auto Guidance line may move if you change this setting while navigating. The available values for the Shoreline Distance setting are relative, not absolute. To ensure the Auto Guidance line is placed the appropriate distance from shore, you can assess the placement of the Auto Guidance line using one or more familiar destinations that require navigation through a narrow waterway.

- 1 Dock your vessel or drop the anchor.
- 2 Select **Settings > Preferences > Navigation > Auto Guidance > Shoreline Distance > Normal**.
- 3 Select a destination that you have navigated to previously.
- 4 Select **Navigate To > Auto Guidance**.
- 5 Review the placement of the Auto Guidance line, and determine whether the line safely avoids known obstacles and the turns enable efficient travel.
- 6 Select an option:
  - If the placement of the Auto Guidance line is satisfactory, select **MENU > Navigation Options > Stop Navigation**, and proceed to step 10.
  - If the Auto Guidance line is too close to known obstacles, select **Settings > Preferences > Navigation > Auto Guidance > Shoreline Distance > Far**.
  - If the turns in the Auto Guidance line are too wide, select **Settings > Preferences > Navigation > Auto Guidance > Shoreline Distance > Near**.
- 7 If you selected **Near** or **Far** in step 6, review the placement of the Auto Guidance line, and determine whether the line safely avoids known obstacles and the turns enable efficient travel.

Auto Guidance maintains a wide clearance from obstacles in open water, even if you set the Shoreline Distance setting to Near or Nearest. As a

result, the AQUAMAP may not reposition the Auto Guidance line, unless the destination selected requires navigation through a narrow waterway.

- 8 Select an option:
  - If the placement of the Auto Guidance line is satisfactory, select **MENU > Navigation Options > Stop Navigation**, and proceed to step 10.
  - If the Auto Guidance line is too close to known obstacles, select **Settings > Preferences > Navigation > Auto Guidance > Shoreline Distance > Farthest**.
  - If the turns in the Auto Guidance line are too wide, select **Settings > Preferences > Navigation > Auto Guidance > Shoreline Distance > Nearest**.
- 9 If you selected **Nearest** or **Farthest** in step 8, review the placement of the **Auto Guidance** line, and determine whether the line safely avoids known obstacles and the turns enable efficient travel.

Auto Guidance maintains a wide clearance from obstacles in open water, even if you set the Shoreline Distance setting to Near or Nearest. As a result, the AQUAMAP may not reposition the Auto Guidance line, unless the destination selected requires navigation through a narrow waterway.
- 10 Repeat steps 3 through 9 at least once more, using a different destination each time, until you are familiar with the functionality of the Shoreline Distance setting.

## Boundaries

Boundaries allow you to avoid or remain in designated areas in a body of water. You can set an alarm to alert you when you enter or exit a boundary.

You can create boundary areas, lines, and circles using the map. You can also convert saved tracks and routes into boundary lines. You can create a boundary area using waypoints by creating a route from the waypoints, and converting the route into a boundary line.

You can select a boundary to act as the active boundary. You can add the

active boundary data to the data fields on the chart.

## Creating a Boundary

- 1 Select **NAV INFO > User Data > Boundaries > New**.
- 2 Select a boundary shape.
- 3 Follow the on-screen instructions.

## Converting a Route to a Boundary

Before you can convert a route to a boundary, you must create and save at least one route.

- 1 Select **NAV INFO > User Data > Routes**.
- 2 Select a route.
- 3 Select **Review > Edit Route > Save as Boundary**.

## Converting a Track to a Boundary

Before you can convert a track to a boundary, you must record and save at least one track.

- 1 Select **NAV INFO > User Data > Tracks > Saved Tracks**.
- 2 Select a track.
- 3 Select **SELECT > Edit Track > Save as Boundary**.

## Editing a Boundary

- 1 Select **NAV INFO > User Data > Boundaries**.
- 2 Select a boundary.
- 3 Select **Review > Edit Boundary**.
- 4 Select an option:
  - To edit the appearance of the boundary on the chart, select **Display Options**.
  - To change the boundary lines or name, select **Edit Boundary**.

- To edit the boundary alarm, select **Alarm**.

## Setting a Boundary Alarm

Boundary alarms alert you when you are within a specified distance of a set boundary.

- 1 Select **NAV INFO > User Data > Boundaries**.
- 2 Select a boundary.
- 3 Select **Alarm > On**.
- 4 Enter a distance.

## Deleting a Boundary

- 1 Select **NAV INFO > User Data > Boundaries**.
- 2 Select a boundary.
- 3 Select **Review > Edit Boundary > Delete**.

## Synchronizing User Data Across the Garmin Marine Network

### NOTICE

Before you synchronize the user data across the network, you should backup your user data to prevent possible data loss.

You can share waypoints, tracks, and routes with all compatible devices connected to the Garmin Marine Network (Ethernet) automatically.

**NOTE:** This feature is not available on all models.

Select **Settings > Preferences > User Data Sharing > On**.

If a change is made to a waypoint, track, or route on one AQUAMAP, that data is synchronized automatically across all AQUAMAPs on the Ethernet network.

## Deleting All Saved Waypoints, Routes, and Tracks

Select **NAV INFO > User Data > Clear User Data > All > OK**.

## Sailing Features

### Setting the Vessel Type

You can select your boat type to configure the AQUAMAP settings and to use features customized for your boat type.

- 1 Select **Settings > My Vessel > Vessel Type**.
- 2 Select an option.

### Sail Racing

You can use the device to increase the likelihood that your boat will cross the start line of a race exactly when the race begins. When you synchronize the race timer with the official race countdown timer, you are alerted at one-minute intervals as the race start approaches. When you combine the race timer with the virtual start line, the device measures your speed, bearing, and remaining time on the countdown timer. The device uses this data to indicate whether your boat will cross the start line before, after, or at the correct time to start the race.

### Starting Line Guidance

Sailing start line guidance is a visual representation of the information you need to cross the start line at the optimal time and speed.

After you set the starboard and port start line pins, and the target speed and time, and after you start the race timer, a predictor line appears. The predictor line extends from your current location toward the start line and the laylines that extend from each pin.

The end point and color of the predictor line indicate where the boat will be when the timer expires, based on your current boat speed.

When the end point is before the start line, the line is white. This indicates the boat must increase speed to reach the start line on time.

When the end point is past the start line, the line is red. This indicates the

boat must reduce speed to avoid a penalty for reaching the start line before the timer expires.

When the end point is on the start line, the line is white. This indicates the boat is moving at an optimal speed to reach the start line when the timer expires.

By default, the start line guidance window and the race timer window appear in the Sail Racing combination screen.

### **Setting the Starting Line**

- 1 From the Start Line Guidance gauge, select **MENU > Sailing > Start Line**.
- 2 Select an option:
  - To mark the port and starboard starting line marks as you sail past them, select **Ping Marks**.
  - To mark the port and starboard starting line marks by entering their coordinates, select **Enter Coordinates**.
  - To switch the position of the port and starboard marks after you have set them, select **Swap Port & Starbd. Marks**.

### **Using the Starting Line Guidance**

You can use the starting line guidance feature to help get you cross the start line, at the optimal speed during a sailing race.

- 1 Mark the starting line.
- 2 From the Sail Racing combination screen, select **MENU > Start Line > Target Speed**, and select your target speed when crossing the starting line.
- 3 Select **Target Time**, and select the target time to cross the starting line.
- 4 Select **BACK**.
- 5 Start the racing timer.

### **Starting the Race Timer**

The race timer is added to the Sail Racing combination screen by default.

- 1 From the Sail Racing combination screen, select **Start**.

**NOTE:** You can also access this from the Sailing SmartMode screen and the Nav. chart.

- 2 When necessary, select **Sync** to synchronize with the official race timer.

### **Stopping the Race Timer**

From the starting line guidance gauge, select **Stop**.

### **Setting the Distance between the Bow and the GPS Antenna**

You can enter the distance between the bow of your boat and the location of your GPS antenna. This helps ensure the bow of your boat crosses the starting line at the precise start time.

- 1 From a Nav. chart, select **MENU > Sailing > Start Line > GPS Bow Offset**.
- 2 Enter the distance.
- 3 Select **Done**.

## **Laylines Settings**

To use the laylines features, you must connect a wind sensor to the AQUAMAP.

When in sailing mode, you can display laylines on the Nav. chart. Laylines can be very helpful when racing.

From the Nav. chart, select **MENU > Sailing > Laylines**.

**Display:** Sets how the laylines and vessel appear on the chart, and sets the length of the laylines.

**Sailing Ang.:** Allows you to select how the device calculates laylines. The Actual option calculates the laylines using the measured wind angle from

the wind sensor. The Manual option calculates the laylines using manually entered windward and leeward angles.

**Windward Ang.:** Allows you to set a layline based on the windward sailing angle.

**Leeward Ang.:** Allows you to set a layline based on the leeward sailing angle.

**Tide Correction:** Corrects the laylines based on the tide.

**Layline Filter:** Filters the layline data based on the time interval entered.

For a smoother layline that filters out some of the changes in the boat's heading or true wind angle, enter a higher number. For laylines that display a higher sensitivity to changes in the boat's heading or true wind angle, enter a lower number.

## Setting the Keel Offset

You can enter a keel offset to compensate the water depth reading for the transducer installation location. This allows you to view the depth of the water below the keel or the true depth of the water, depending on your needs.

**NOTE:** This option is only available when you have valid depth data.

1 Measure the distance:

- If the transducer is installed at the water line ① or anywhere above the end of the keel, measure the distance from the transducer location to the keel of the boat. Enter this value as a positive number.
- If the transducer is installed at the bottom of the keel ② and you want to know the true depth of the water, measure the distance from the transducer to the water line. Enter this value in as a negative number.

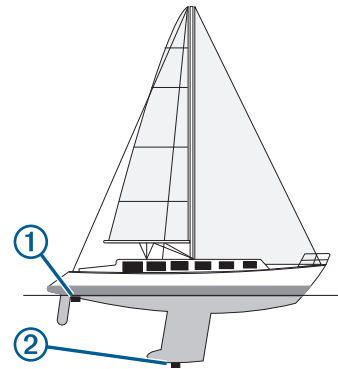

- 2 Select **Settings > My Vessel > Depth and Anchoring > Keel Offset**.
- 3 Select **+** if the transducer is installed at the water line, or select **-** if the transducer is installed at the bottom of the keel.
- 4 Use the arrow keys to enter the keel offset measured in step 1.

## Sailboat Autopilot Operation

### ⚠ CAUTION

When engaged, the autopilot controls only the rudder. You and your crew remain responsible for the sails while the autopilot is engaged.

In addition to heading hold, you can use the autopilot to maintain a wind hold. You can also use the autopilot to control the rudder while tacking and gybing.

### Wind Hold

You can set the autopilot to maintain a specific bearing relative to the current wind angle. Your device must be connected to a NMEA 2000 or NMEA® 0183 compatible wind sensor to perform a wind hold or a wind-based tack or gybe.

**NOTE:** Before you can enable the wind hold type, you must connect a NMEA

2000 or NMEA 0183 wind sensor to the autopilot.

### **Setting the Wind Hold Type**

For advanced autopilot configuration, see the installation instructions included with your autopilot.

- 1 From the autopilot screen, select **MENU > Autopilot Setup > Wind Hold Type**.
- 2 Select **Apparent** or **True**.

### **Engaging Wind Hold**

When the autopilot is in standby mode, select **Wind Hold**.

### **Engaging Wind Hold from Heading Hold**

With heading hold engaged, select **MENU > Wind Hold**.

### **Adjusting the Wind Hold Angle with the Autopilot**

You can adjust the wind hold angle on the autopilot when wind hold is engaged.

- To adjust the wind hold angle in increments of 1°, select ◀ or ▶.
- To adjust the wind hold angle in increments of 10°, hold ◀ or ▶.

### **Tack and Gybe**

You can set the autopilot to perform a tack or gybe while heading hold or wind hold is engaged.

### **Tacking and Gybing from Heading Hold**

- 1 Engage heading hold.
- 2 Press **MENU**.
- 3 Select an option.

The autopilot steers your boat through a tack or gybe.

### **Tacking and Gybing from Wind Hold**

Before you can engage wind hold, you must have a wind sensor installed.

- 1 Engage wind hold.
- 2 Press **MENU**.
- 3 Select an option.

The autopilot steers your boat through a tack or gybe, and information about the progress of the tack or gybe appears on the screen.

### **Setting a Tack and Gybe Delay**

The tack and gybe delay allows you to delay steering a tack and gybe after you initiate the maneuver.

- 1 From the autopilot screen, select **MENU > Autopilot Setup > Sailing Setup > Tack Delay**.
- 2 Select the length of the delay.
- 3 If necessary, select **Done**.

### **Enabling the Gybe Inhibitor**

**NOTE:** The gybe inhibitor does not prevent you from manually performing a gybe using the helm or step steering.

The gybe inhibitor prevents the autopilot from performing a gybe.

- 1 From the autopilot screen, select **MENU > Autopilot Setup > Sailing Setup > Gybe Inhibitor**.
- 2 Select **Enabled**.

## **Heading Line and Angle Markers**

The heading line is an extension drawn on the map from the bow of the boat in the direction of travel. Angle markers indicate relative position from the heading or course over ground, which are helpful for casting or finding reference points.

## Setting the Heading and Course Over Ground Lines

You can show the heading line and the course over ground (COG) line on the chart.

COG is your direction of movement. Heading is the direction the bow of the boat is pointed, when a heading sensor is connected.

- 1 From a chart view, select **MENU > Chart Setup > Chart Appearance > Heading Line**.
- 2 If necessary, select **Source**, and select an option:
  - To automatically use the source available, select **Auto**.
  - To use the GPS antenna heading for COG, select **GPS Heading (COG)**.
  - To use data from a connected heading sensor, select **Heading**.
  - To use data from both a connected heading sensor and the GPS antenna, select **COG and Heading**.  
This displays both the heading line and the COG line on the chart.
- 3 Select **Display**, and select an option:
  - Select **Distance > Distance**, and enter the length of the line shown on the chart.
  - Select **Time > Time**, and enter the time used to calculate the distance your boat will travel in the specified time at your present speed.

## Turning on Angle Markers

You can add angle markers to the map along the heading line. Angle markers can be helpful for casting when fishing.

- 1 Set the heading line.
- 2 Select **Angle Markers**.

## Sonar Fishfinder

When properly connected to a transducer, your compatible AQUAMAP can be used as a fishfinder. AQUAMAP models without an xsv or xs in their names require a Garmin sounder module and transducer to display sonar information.

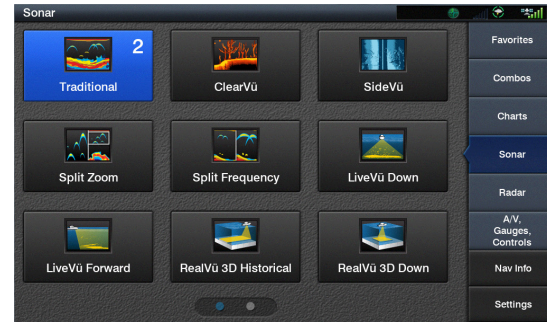

For more information about which transducer is best for your needs, go to [Garmin.com/transducers](http://Garmin.com/transducers).

Different sonar views can help you view the fish in the area. The sonar views available vary depending on the type of transducer and sounder module connected to the AQUAMAP. For example, you can view certain Panoptix sonar screens only if you have a compatible Panoptix transducer connected.

There are four basic styles of sonar views available: a full-screen view, a split-screen view that combines two or more views, a split-zoom view, and a split-frequency view that displays two different frequencies. You can customize the settings for each view in the screen. For example, if you are viewing the split-frequency view, you can separately adjust the gain for each frequency.

If you do not see an arrangement of sonar views to suit your needs, you can create a custom combination screen.

## Traditional Sonar View

There are several full-screen views available, depending on the equipment connected.

The full-screen Traditional sonar view show a large image of the sonar readings from a transducer. The range scale along the right side of the screen shows the depth of detected objects as the screen scrolls from the right to the left.

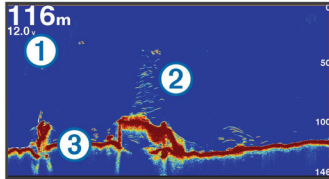

①	Depth and temperature information
②	Suspended targets or fish
③	Bottom of the body of water

## Split-Zoom Sonar View

The split-zoom sonar view shows a full-view graph of sonar readings, and a magnified portion of that graph, on the same screen.

## Split-Frequency Sonar View

In the split-frequency sonar view, one side of the screen shows a full-view graph of high frequency sonar data, and the other side of the screen shows a full-view graph of lower frequency sonar data.

**NOTE:** The split-frequency sonar view requires the use of a dual-frequency transducer.

## Traditional 50/77/200 kHz Sonar

Fishfinder uses ultrasonic signals to detect the bottom of the ocean. Traditional 50/77/200 kHz sonar sends only one frequency at a time. Since the only feedback is from this one single frequency, there is limited information to work with, restricting the clarity and resolution. Lower frequencies with wider sonar beam angle would result in a broader and deeper detectable area. Conversely, higher frequencies with narrower beam angle would result in higher resolution images with better target separation.



## CHIRP Sonar

CHIRP sonar is one of the most sophisticated sonar technologies available for the fishing and boating public. The word is an acronym for Compressed High-Intensity Radiated Pulse (C-H-I-R-P). CHIRP sonar provides amazingly clear target separation and definition because it puts more energy onto the target than traditional sonars.

Instead of sending just one single frequency, CHIRP sonar sends a continuous sweep of frequencies ranging from low to high. Garmin CHIRP sonar technology then interprets each frequency individually upon its return. This provides much more information, from which CHIRP sonar is able to construct a much clearer, higher resolution image with greater target separation and crisper fish arches.

For example, 80-160 kHz sonar sweeps through the entire range from 80 kHz all the way up to 160 kHz, hitting every single frequency in between.

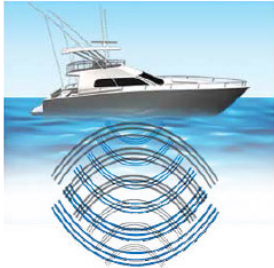

## Garmin ClearVü Sonar View

**NOTE:** To receive Garmin ClearVü scanning sonar, you need a compatible transducer.

Garmin ClearVü high-frequency sonar provides a detailed picture of the fishing environment around the boat in a detailed representation of structures the boat is passing over.

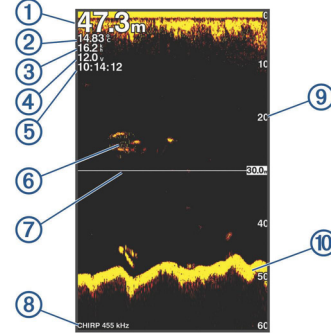

①	Bottom depth
②	Water temperature
③	GPS speed
④	Device voltage
⑤	Time
⑥	Suspended targets (fish)
⑦	Depth line
⑧	Transducer type and frequency, and zoom type
⑨	Depth indicator as the sonar data screen scrolls from right to left
⑩	Bottom echo

## ClearVü Scanning Sonar

The Garmin ClearVü scanning sonar technology emits two narrow beams with CHIRP technology, similar to the shape of the beam in a copying machine.

This Garmin high-frequency scanning sonar (260/455/800 kHz) provides a much clearer, picture-like image of what lies under the water by producing a more detailed representation of objects, structures and fish under your boat.

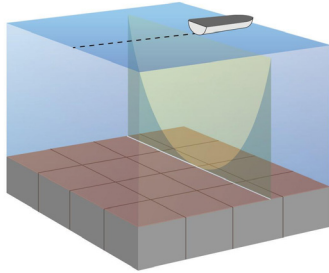

## SideVü Sonar View

**NOTE:** Not all models provide built-in SideVü sonar support. If your model does not provide built-in SideVü sonar, you need a compatible sounder module and compatible SideVü transducer. If your model does provide built-in SideVü sonar, you need a compatible SideVü transducer.

SideVü scanning sonar technology shows you a picture of what lies to the sides of the boat. You can use this as a search tool to find structures and fish.

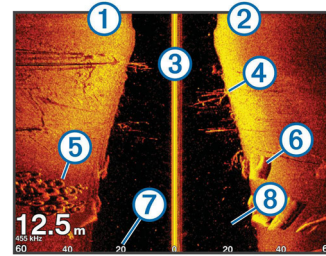

①	Left side of the boat
②	Right side of the boat
③	The transducer on your vessel
④	Trees
⑤	Old tires
⑥	Logs
⑦	Distance from the side of the boat
⑧	Water between the vessel and the bottom

## SideVü Scanning Technology

Instead of a more common conical beam, the SideVü transducer uses a flat beam to scan the water and bottom to the sides of your boat.

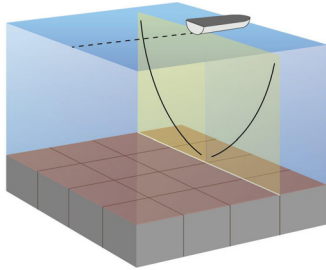

## Measuring Distance on the Sonar Screen

You can measure the distance between two points on the SideVü sonar view.

1 From the SideVü sonar view, select a location on the screen.

2 Select **Measure Distance**.

A push pin appears on the screen at the selected location.

3 Select another location.

The distance and angle from the pin is listed in the upper-left corner.

**TIP:** To reset the pin and measure from the current location of the pin, select **Measure Distance**.

## Panoptix Sonar Views

**NOTE:** Not all models support Panoptix transducers.

To receive Panoptix sonar, you need a compatible AQUAMAP and a compatible transducer.

The Panoptix sonar views allow you to see all around the boat in real time. You can also watch your bait underwater and bait schools in front of or below

your boat.

The LiveVü sonar views provide you a view of the live movement either in front of or below your boat. The screen updates very quickly, producing sonar views that look more like live video.

The RealVü 3D sonar views provide three-dimensional views of either what is in front of or below your boat. The screen updates with each sweep of the transducer.

To see all five Panoptix sonar views, you need one transducer to show the down views and a second transducer to show the forward views.

## LiveVü Down Sonar View

This sonar view shows a two-dimensional view of what is below the boat and can be used to see a bait ball and fish.

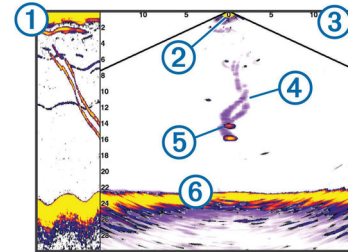

①	Panoptix down view history in a scrolling sonar view
②	Boat
③	Range
④	Trails
⑤	Drop shot rig
⑥	Bottom

## LiveVü Forward Sonar View

This sonar view shows a two-dimensional view of what is in front of the boat and can be used to see a bait ball and fish.

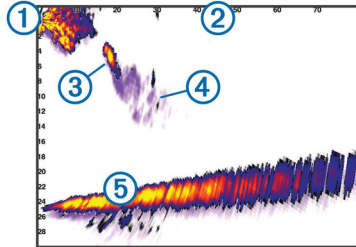

①	Boat
②	Range
③	Fish
④	Trails
⑤	Bottom

## RealVü 3D Historical Sonar View

This sonar view provides a three-dimensional view of what is behind your boat as you are moving and shows the entire water column in 3D, from the bottom to the top of the water. This view is used for finding fish.

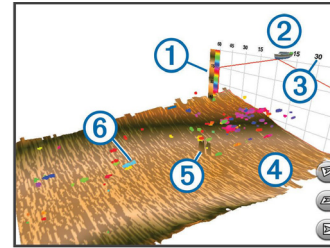

①	Color legend
②	Boat
③	Range
④	Bottom
⑤	Structure
⑥	Fish

## RealVü 3D Down Sonar View

This sonar view shows a three-dimensional view of what is below the transducer and can be used when you are stationary and want to see what is around your boat.

## RealVü 3D Forward Sonar View

This sonar view shows a three-dimensional view of what is in front of the transducer. This view can be used when you are stationary and you need to see the bottom and the fish approaching the boat.

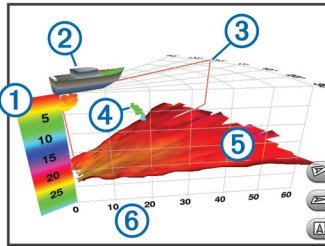

①	Color legend
②	Boat
③	Ping indicator
④	Fish
⑤	Bottom
⑥	Range

## FrontVü Sonar View

The Panoptix FrontVü sonar view increases your situational awareness by showing obstructions under the water, up to 91 meters (300 feet) in front of the boat.

The ability to effectively avoid forward collisions with FrontVü sonar decreases as your speed rises above 8 knots.

To see the FrontVü sonar view, you must install and connect a compatible transducer, such as a PS21 transducer. You may need to update the transducer software.

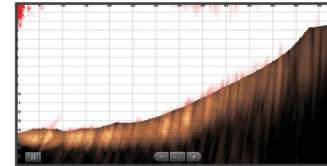

## Changing the Sonar View

- 1 From a combination screen with sonar, select the window to change.
- 2 Select **MENU > Edit Combo**.
- 3 Select a sonar view.

## Selecting the Transducer Type

Before you can select the transducer type, you must know what kind of transducer you have.

This AQUAMAP is compatible with the Garmin ClearVü™ transducer as well as a range of accessory transducers including Garmin GT transducers, which are available at [Garmin.com](http://Garmin.com). For information about compatible transducers, go to [Garmin.com/transducers](http://Garmin.com/transducers).

If you are connecting a transducer that was not included with the AQUAMAP, you may need to set the transducer type to make the sonar function properly.

If the device automatically detected your transducer, this option does not appear.

- 1 From a sonar view, select **MENU > Sonar Setup > Installation > Transducer Type**.
- 2 Select an option:
  - If you have a 200/77 kHz, dual-beam transducer, select **Dual Beam (200/77 kHz)**.
  - If you have a 200/50 kHz, dual-frequency transducer, select **Dual Frequency (200/50 kHz)**.
  - If you have another type of transducer, select it from the list.

## Calibrating the Compass

Before you can calibrate the compass, the transducer must be installed on the shaft far enough away from the trolling motor to avoid magnetic interference, and deployed in the water. Calibration must be of sufficient quality to enable the internal compass.

**NOTE:** To use the compass, you must mount the transducer on the shaft. The compass does not work when you mount the transducer on the motor.

**NOTE:** Compass calibration is available only for transducers with an internal compass, such as the PS21-TR transducer.

You can begin turning your boat before calibrating, but you must fully rotate your boat 1.5 times during calibration.

- 1 From an applicable sonar view, select **MENU > Sonar Setup > Installation**.
- 2 If necessary, select **Use AHRS** to turn on the AHRS sensor.
- 3 Select **Calibrate Compass**.
- 4 Follow the on-screen instructions.

## Pausing the Sonar Display

Use the arrow key to move the cursor and pause the display.

## Creating a Waypoint on the Sonar Screen

- 1 From a sonar view, select a location.
- 2 Select **New Wpt**.
- 3 If necessary, edit the waypoint information.

## Viewing Sonar History

You can scroll the sonar display to view historical sonar data.

**NOTE:** Not all transducers save historical sonar data.

- 1 From a sonar view, hold  to scroll through the history.
- 2 Select **BACK** to exit history.

## Stopping the Transmission of Sonar Signals

From a sonar screen, select **MENU > Transmit**.

## Sonar Sharing

This feature may not be available on all AQUAMAP models.

You can view the sonar data from all compatible sources on the Garmin Marine Network. You can view sonar data from a compatible external sonar module, such as a GCV™ sonar module. In addition, you can view the sonar data from other AQUAMAPs that have a built-in sonar module.

Each AQUAMAP on the network can display sonar data from every compatible sonar module and transducer on the network, no matter where the AQUAMAPs and transducers are mounted on your boat. For example, from a transducer with Garmin ClearVü mounted at the back of the boat, you can view the sonar data using the 922 mounted at the front of your boat.

When sharing sonar data, the values of some sonar settings, such as

Range and Gain, are synchronized across the devices on the network. The values of other sonar settings, such as the Appearance settings, are not synchronized and should be configured on each individual device. In addition, the scroll rates of the various traditional and Garmin ClearVü sonar views are synchronized to make the split views more cohesive.

**NOTE:** Using multiple transducers simultaneously can create cross talk, which can be removed by adjusting the Interference sonar setting.

## Selecting a Sonar Source

This feature may not be available with all models.

When you are using more than one sonar data source for a particular sonar view, you can select the source to use for that sonar view. For example, if you have two sources for Garmin ClearVü, you can select the source to use from the Garmin ClearVü sonar view.

- 1 Open the sonar view for which you will change the source.
- 2 Select **MENU > Sonar Setup > Source**.
- 3 Select the source for this sonar view.

## Renaming a Sonar Source

You can rename a sonar source to easily identify that source. For example, you use “Bow” as the name of the transducer on the bow of your boat.

The source is renamed for the present view only. For example, to rename the Garmin ClearVü sonar source, you must open the Garmin ClearVü sonar view.

- 1 From the sonar view, select **MENU > Sonar Setup > Source > Rename Sources**.
- 2 Enter the name.

## Adjusting the Level of Detail

You can control the level of detail and noise shown on the sonar screen either

by adjusting the gain for traditional transducers or by adjusting the brightness for Garmin ClearVü transducers.

If you want to see the highest intensity signal returns on the screen, you can lower the gain or brightness to remove lower intensity returns and noise. If you want to see all return information, you can increase the gain or brightness to see more information on the screen. This also increases noise, and can make it more difficult to recognize actual returns.

- 1 From a sonar view, press **MENU**.
- 2 Select **Gain** or **Brightness**.
- 3 Select an option:
  - To increase or decrease the gain or brightness manually, turn the knob.
  - To allow the AQUAMAP to adjust the gain or brightness automatically, select an automatic option.

## Adjusting the Color Intensity

You can adjust the intensity of colors and highlight areas of interest on the sonar screen by adjusting the color gain for traditional transducers or the contrast for Garmin ClearVü and SideVü/ClearVü transducers. This setting works best after you have adjusted the level of detail shown on the screen using the gain or brightness settings.

If you want to highlight smaller fish targets or create a higher intensity display of a target, you can increase the color gain or contrast setting. This causes a loss in the differentiation of the high intensity returns at the bottom. If you want to reduce the intensity of the return, you can reduce the color gain or contrast.

- 1 From a sonar view, press **MENU**.
- 2 Select **Gain** or **Contrast**.
- 3 Select an option:
  - To increase or decrease the color intensity manually, turn the knob.
  - To use the default setting, select **Default**.

## Sonar Frequencies

**NOTE:** The frequencies available depend on the AQUAMAP, sounder modules, and transducer being used.

Adjusting the frequency helps adapt the sonar for your particular goals and the present depth of the water.

Higher frequencies use narrow beam widths, and are better for high-speed operation and rough sea conditions. Bottom definition and thermocline definition can be better when using a higher frequency.

Lower frequencies use wider beam widths, which can let the fisherman see more targets, but could also generate more surface noise and reduce bottom signal continuity during rough sea conditions. Wider beam widths generate larger arches for fish target returns, making them ideal for locating fish. Wider beam widths also perform better in deep water, because the lower frequency has better deep water penetration.

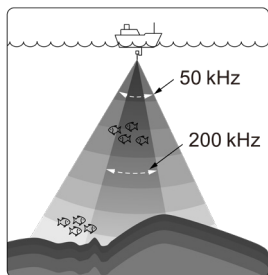

*Frequency and coverage area*

CHIRP frequencies allow you to sweep each pulse through a range of frequencies, resulting in better target separation in deep water. CHIRP can be used to distinctly identify targets, like individual fish in a school, and for deep water applications. CHIRP generally performs better than single frequency applications. Because some fish targets may show up better using a fixed

frequency, you should consider your goals and water conditions when using CHIRP frequencies.

Some sonar black boxes and transducers also provide the ability to customize preset frequencies for each transducer element, which enables you to change the frequency quickly using the presets as the water and your goals change.

Viewing two frequencies concurrently using the split-frequency view allows you to see deeper with the lower frequency return and, at the same time, see more detail from the higher frequency return.

### Selecting Frequencies

**NOTE:** You cannot adjust the frequency for all sonar views and transducers.

You can indicate which frequencies appear on the sonar screen.

- 1 From a sonar view, select **MENU > Frequency**.
- 2 Select an option:
  - To use CHIRP frequencies, select **Chirp**.
  - To detect and judge the bottom condition, select **50.0 kHz**.
  - To detect schools of fish at the bottom on the edges, select **95.0 kHz**.
  - For detailed observations, select **200.0 kHz**.

### Creating a Frequency Preset

**NOTE:** Not available with all transducers.

You can create a preset to save a specific sonar frequency, which allows you to change frequencies quickly.

- 1 From a sonar view, select **MENU > Frequency**.
- 2 Select **Manage Frequencies > New Preset**.
- 3 Enter a frequency.

## Adjusting the Zoom on the Sonar Screen

- 1 From an applicable sonar view, select **MENU > Zoom**.
- 2 Select an option:
  - To set the depth range of the magnified area manually, select **Set Zoom**, turn the knob to set the depth range of the magnified area, select **Zoom In** or **Zoom Out** to increase or decrease the magnification of the magnified area,
  - To set the zoom range automatically, select **Set Zoom > Auto**.
  - To lock the screen to the water bottom, select **Bottom Lock**.
  - To lock the screen to a specific depth and range, select **Shift Zoom**.
  - To cancel the zoom, select **No Zoom**.

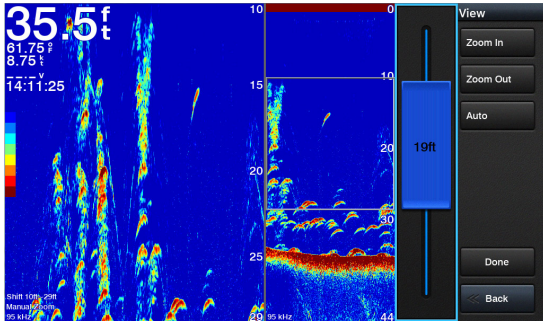

### Auto

Auto zoom is similar to Bottom Lock but displays a magnified view of the bottom and bottom fish in the set zoom range. The Auto mode is good for determining the bottom contour. It allows you to change the depth range above the bottom and the zoom ratio while always showing the water bottom.

From a sonar screen select **MENU > ZOOM > Set Zoom > Auto**.

### Bottom Lock

You can lock the screen to the water bottom. For example, if you select a span of 20 meters, the device shows an area from the water bottom to 20 meters above the bottom. It is useful for detecting fish close to the bottom. The span appears on the right side.

- 1 From a sonar view, select **MENU > ZOOM > Bottom Lock**.
- 2 Select **▲** or **▼** to adjust the span above the bottom.
- 3 Select **Adjust > Bottom** and select **▲** or **▼** to manually adjust the bottom level.

### Shift Zoom

This is a unique sonar zoom technology from Garmin. It displays the selected depth and range of sonar to fill the screen in more accuracy and detail. In the Shift Zoom mode the fishfinder CPU only processes the sonar signals received from the selected depth range. You can set the zoom manually.

- 1 From a sonar screen select **MENU > ZOOM > Shift Zoom**.
- 2 Select **▲** or **▼** to adjust the shift, AQUAMAP automatically zooms in or out to fill the screen.
- 3 Select **Off** to set shift to 0 m.

### Target Expansion

In a traditional, ClearVü, or SideVü sonar view, you can manually zoom in and out to an area of interest using the arrow keys and the knob.

- 1 From a traditional, ClearVü, or SideVü sonar view, move the cursor to the target area using the arrow keys.
- 2 Zoom in and out on the cursor by turning the knob.

### Adjusting the Range of the Depth or Width Scale

You can adjust the range of the depth scale traditional and ClearVü sonar views and the range of the width scale for the SideVü sonar view.

Allowing the device to adjust the range automatically keeps the bottom within the lower or outer third of the sonar screen, and can be useful for tracking a bottom that has minimal or moderate terrain changes.

Manually adjusting the range enables you to view a specified range, which can be useful for tracking a bottom that has large terrain changes, such as drop-offs or cliffs. The bottom can appear on the screen as long as it appears within the range you have set.

- 1 From an applicable sonar view, select **MENU > Range**.
- 2 Select an option:
  - To allow the AQUAMAP to adjust the range automatically, select **Auto**.
  - To increase or decrease the range manually, use the knob.

**TIP:** From the sonar screen, you can turn the knob to manually adjust the range.

**TIP:** When viewing multiple sonar screens, you can press **SELECT** to choose the active screen.

## Traditional, Garmin ClearVü, and SideVü Sonar Setup

**NOTE:** Not all options and settings apply to all models, sounder modules, and transducers.

**NOTE:** These settings do not apply to Panoptix transducers.

From an applicable sonar view, select **MENU > Sonar Setup / ClearVü Setup / SideVü Setup**.

**Scroll Speed:** Sets the rate at which the sonar scrolls from right to left. In shallow water, you can select a slower scroll speed to extend the length of time the information is displayed on screen. In deeper water, you can select a faster scroll speed. Automatic scroll speed adjusts the scrolling speed to the speed the boat is traveling.

**Noise Reject:** Reduces the interference and the amount of clutter shown on the sonar screen.

**Appearance:** Configures the appearance of the sonar screen.

**Alarms:** Sets sonar alarms.

**Advanced:** Configures various sonar display and data source settings. Not applicable to Garmin ClearVü or SideVü sonar views.

**Installation:** Configures the transducer.

## Setting the Scroll Speed

You can set the rate at which the sonar image moves across the screen. A higher scroll speed shows more detail, especially while moving or trolling. A lower scroll speed displays sonar information on the screen longer. Setting the scroll speed on one sonar view applies to all the sonar views.

- 1 From an applicable sonar view, select **MENU > Sonar Setup / ClearVü Setup / SideVü Setup > Scroll Speed**.
- 2 Select an option:
  - To use a very fast scroll speed, select **Ultrasroll**<sup>®</sup>. The Ultrasroll option quickly scrolls new sonar data, but with a reduced image quality. For most situations, the Fast option provides a good balance between a quickly scrolling image and targets that are less distorted.
  - Select **Fast**, **Medium**, or **Slow** to set the scroll speed manually.
  - To adjust the scroll speed automatically using speed-over-ground or water speed data, select **Auto**. The Auto setting selects a scroll rate to match the boat speed, so targets in the water are drawn with the correct aspect ratio and appear less distorted. When viewing Garmin ClearVü or SideVü sonar views, it is recommend to use the Auto setting.

## Sonar Noise Rejection Settings

From an applicable sonar view, select **MENU > Sonar Setup / ClearVü Setup / SideVü Setup > Noise Reject**.

**Interference:** Adjusts the sensitivity to reduce the effects of interference from nearby sources of noise.

The lowest interference setting that achieves the desired improvement should be used to remove interference from the screen. Correcting

installation issues that cause noise is the best way to eliminate interference.

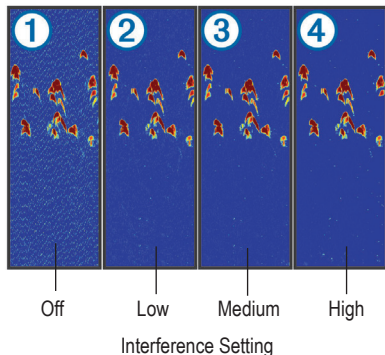

Interference from other acoustic equipment operating nearby or other electronic equipment on your boat may appear on the display as shown in the figures below. You may reduce the effect with a noise limiter. There are varying degrees of interference. Minor interference or noise can be stray signals that can look like actual targets. Severe noise can completely fill the screen and make depth readings impossible. To counter interference, you have to first identify the type of interference. Although most noises can be eliminated with fairly simple techniques, some interferences can only be reduced to a more acceptable level.

**Sonar Cross-Talk interference:** caused by nearby sonar of similar transmit frequency. It will appear as the diagonal lines across the screen. When two sonar's transducer cones intersect, the units will not be able to tell the signals apart. See figure (A) below.

**Electromagnetic Interference (EMI):** caused by powerful electromagnetic waves radiated from electric equipment and wirings. The electromagnetic waves are then absorbed by the transducer cable and appear as vertical lines on the screen. See figure (B) below.

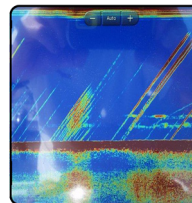

(A) Interference from other sonar

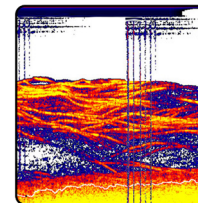

(B) Electrical interference

**Color Limit:** Hides part of the color palette to help eliminate fields of weak clutter.

By setting the color limit to the color of the undesired returns, you can eliminate the display of undesired returns on the screen.

**Smoothing:** Removes noise that is not part of a normal sonar return, and adjusts the appearance of returns, such as the bottom.

When smoothing is set to high, more of the low-level noise remains than when using the interference control, but the noise is more subdued because of averaging. Smoothing can remove speckle from the bottom. Smoothing and interference work well together to eliminate low-level noise. You can adjust the interference and smoothing settings incrementally to remove undesirable noise from the display.

**Surface Noise:** Hides surface noise to help reduce clutter. Wider beam widths (lower frequencies) can show more targets, but can generate more surface noise.

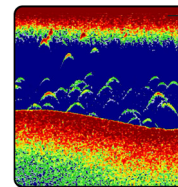

Surface noise

**TVG:** The TVG (Time Variable Gain) compensates for propagation loss

of sound, so that the echoes from fish schools of the same size are displayed in the same color. Avoid excessive TVG; weak echoes may not be displayed. The TVG is also useful for reducing surface noise. TVG is intended to compensate for the fact that close-in returns provide a louder echo than further-away ones by using a lower gain level in the period immediately after the sounder stops transmitting its ping (echoes from nearby objects) and then ramping up the gain level over time as the ping travels into deeper water, attenuating as it goes.

Adjusts the appearance of returns to compensate for weakened sonar signals in deeper water, and reduces the appearance of noise near the surface. When the value of this setting is increased, the colors associated with low-level noise and fish targets appear more consistent through various water depths. The ideal end result of using TVG appropriately is that if you increase Gain until you see a lot of clutter on the screen, the amount of clutter should spread evenly throughout the depth of the water column.

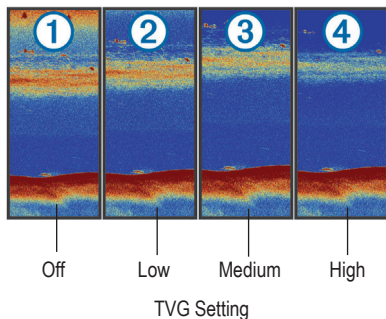

**Color Filter:** Shows or hides individual colors to customize the appearance of sonar returns.

**Color Bar:** Shows or hides the color legend.

## Sonar Appearance Settings

From an applicable sonar view, select **MENU > Sonar Setup / ClearVü Setup / SideVü Setup > Appearance**.

**Color Scheme:** Sets the color palette.

**Color Gain:** Adjusts the intensity of colors shown on the screen. You can select a higher color gain value to see targets higher in the water column. A higher color gain value also allow you to differentiate low intensity returns higher in the water column, but this causes a loss in the differentiation of the returns at the bottom. You can select a lower color gain value when targets are near the bottom, to help you distinguish between targets and high intensity returns such as sand, rock, and mud.

**Overlay Data:** Sets the data shown on the sonar screen.

**A-Scope:** Displays a vertical flasher along the right side of the screen that shows instantaneously the range to targets along a scale.

**Depth Line:** Shows a quick-reference depth line.

**Whiteline:** Highlights the strongest signal from the bottom to help define the hardness or softness of the signal.

**Pic. Advance:** Allows the sonar picture to advance faster by drawing more than one column of data on the screen for each column of sounder data received. This is especially helpful when you are using the sounder in deep water, because the sonar signal takes longer to travel to the water bottom and back to the transducer.

The 1/1 setting draws one column of information on the screen per sounder return. The 2/1 setting draws two columns of information on the screen per sounder return, and so on for the 4/1 and 8/1 settings.

**Fish Symbols:** Shows the position and size of schools of fish using symbols and numbers.

### Turning On the A-Scope

**NOTE:** This feature is available in the Traditional sonar views.

The a-scope is a vertical flasher along the right side of the view, showing you what is underneath the transducer right now. You can use the a-scope to identify target returns that may be missed when the sonar data is quickly scrolling across the screen, such as when your boat is moving at high speeds. It can also be helpful for detecting fish that are close to the bottom.



The a-scope above shows fish returns ① and a soft bottom return ②.

1 From a sonar view, select **MENU > Sonar Setup > Appearance > A-Scope > On**.

2 Select a hold time.

You can increase the hold time to increase the length of time the sonar returns are displayed.

## Sonar Alarms

**NOTE:** Not all options are available on all transducers.

From an applicable sonar view, select **MENU > Sonar Setup / ClearVü Setup / SideVü Setup > Alarms**.

You can also open the sonar alarms by selecting **Settings > Alarms > Sonar**.

**Shallow Water:** Sets an alarm to sound when the depth is less than the specified value.

**Deep Water:** Sets an alarm to sound when the depth is greater than the specified value.

**FrontVü Alarm:** Sets an alarm to sound when the depth in front of the

vessel is less than the specified value, which can help you avoid running aground. This alarm is available only with Panoptix FrontVü transducers.

**Water Temp.:** Sets an alarm to sound when the transducer reports a temperature that is 2°F (1.1°C) above or below the specified temperature.

**Contour:** Sets an alarm to sound when the transducer detects a suspended target within the specified depth from the surface of the water and from the bottom.

**Fish:** Sets an alarm to sound when the device detects a suspended target.

- sets the alarm to sound when fish of all sizes are detected.
- sets the alarm to sound only when medium or large fish are detected.
- sets the alarm to sound only when large fish are detected.

## Advanced Sonar Settings

From a Traditional sonar view, select **MENU > Sonar Setup > Advanced**.

**Shift:** Allows you to set the depth range on which the sonar is focused. This allows you to zoom in a higher resolution in the focused depth. When using shift, bottom tracking may not work effectively, because the sonar looks for data within the depth range of the focused area, which may not include the bottom. Using shift also can impact the scroll speed, because data outside the depth range of the focused area is not processed, which reduces the time required to receive and display the data. You can zoom in to the focused area, which enables you to evaluate target returns more closely at a higher resolution than just zooming alone.

**Echo Stretch:** Adjusts the size of the echoes on the screen to make it easier to see separate returns on the screen.

When targets are difficult to see ①, echo stretch makes the target returns more pronounced and easier to see on the screen. If the echo stretch value is too high, the targets blend together. If the value is too low ②, the targets are small and more difficult to see.

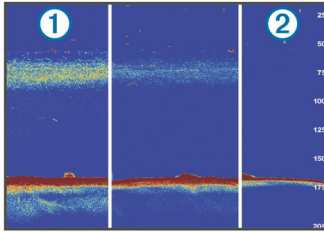

You can use echo stretch and filter width together to obtain the preferable resolution and noise reduction. With echo stretch and filter width set to low, the display has the highest resolution, but is the most susceptible to noise. With echo stretch set to high and filter width set to low, the display has a lower resolution, but has wider targets. With echo stretch and filter width set to high, the display has the lowest resolution, but is the least susceptible to noise. It is not recommended to set echo stretch to low and filter width to high.

### Transducer Installation Settings

From an applicable sonar view, select **MENU > Sonar Setup / ClearVü Setup / SideVü Setup > Installation.**

**Transmit Rate:** Sets the length of time between sonar pings. Increasing the transmit rate increases the scroll speed, but it may also increase self-interference.

Reducing the transmit rate increases the spacing between transmit pulses and can resolve self-interference. This option is available on the Traditional sonar view only.

**Transmit Power:** Reduces transducer ringing near the surface. A lower transmit power value reduces transducer ringing, but can also reduce the strength of the returns. This option is available on the Traditional sonar view only.

**Filter Width:** Defines the edges of the target. A shorter filter more clearly

defines the edges of the targets but may allow more noise. A longer filter creates softer target edges and may also reduce noise. This option is available on the Traditional sonar view only.

**Flip Left/Right:** Switches the SideVü view orientation from left to right. This option is available on the SideVü sonar view only.

**Restore Sonar Defaults:** Restores the sonar settings to the factory default values.

**Transducer Diagnostics:** Shows details about the transducer.

## Sonar Recordings

### Recording the Sonar Display

**NOTE:** Not all models support sonar recording.

- 1 Insert a memory card into the card slot.
- 2 From a sonar view, select **MENU > Sonar Setup > Sonar Recording > Record Sonar.**

15 minutes of sonar recording uses approximately 200 MB of space of the inserted memory card. You can record sonar until the card reaches capacity.

### Stopping the Sonar Recording

Before you can stop recording sonar, you must begin recording it.

From a sonar view, select **MENU > Sonar Setup > Sonar Recording > Stop Recording.**

### Deleting a Sonar Recording

- 1 Insert a memory card into the card slot.
- 2 From a sonar view, select **MENU > Sonar Setup > Sonar Recordings > View Recordings.**
- 3 Select a recording.

#### 4 Select Delete.

### Playing Sonar Recordings

Before you can play back the sonar recordings, you must download and install the HomePort™ application and record sonar data onto a memory card.

- 1 Remove the memory card from the device.
- 2 Insert the memory card into a card reader attached to a computer.
- 3 Open the HomePort application.
- 4 Select a sonar recording from your device list.
- 5 Right-click the sonar recording in the lower pane.
- 6 Select **Playback**.

### Panoptix Sonar Setup

#### Adjusting the RealVü Viewing Angle and Zoom Level

You can change the viewing angle of the RealVü sonar views. You can also zoom in and out of the view.

From a RealVü sonar view, select an option:

- Press **SELECT** to switch between top, 45 degrees, and side views.
- To adjust the viewing angle manually, use the arrow keys.
- To zoom in and out, turn the knob.

#### RealVü Sonar Settings

From the RealVü 3D sonar view, press **MENU**.

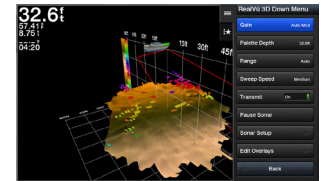
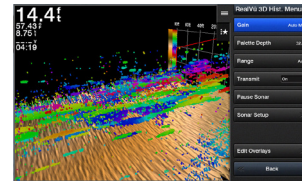

**Gain:** Controls the level of detail and noise shown on the sonar screen.

If you want to see the highest intensity signal returns on the screen, you can lower the gain to remove lower intensity returns and noise. If you want to see all return information, you can increase the gain to see more information on the screen. This also increases noise, and can make it more difficult to recognize actual returns.

**Palette Depth:** Adjusts the depth of the color key on the side of the 3D view. The color key allows a visual reference of the depth of detected objects using different colors.

**Range:** Adjusts the range of the depth scale.

Allowing the device to adjust the range automatically keeps the bottom within the lower portion of the sonar screen, and can be useful for tracking a bottom that has minimal or moderate terrain changes.

Manually adjusting the range enables you to view a specified range, which can be useful for tracking a bottom that has large terrain changes, such as a drop-offs or cliffs. The bottom can appear on the screen as long as it appears within the range you have set.

**Sweep Speed:** Adjusts how quickly the transducer sweeps back and forth.

A faster sweep rate creates a less detailed image, but the screen refreshes faster. A slower sweep rate creates a more detailed image, but the screen refreshes more slowly.

**NOTE:** This feature is not available for the RealVü 3D Historical sonar view.

**Transmit:** Stops the transducer from transmitting.

**Pause Sonar:** Pauses the sonar view.

Press **BACK** to resume.

**Sonar Setup:** Adjusts the setup of the transducer and the appearance of the sonar returns.

**Edit Overlays:** Adjusts the data shown on the screen.

## LiveVü and FrontVü Sonar Settings

From the LiveVü or FrontVü sonar view, press **MENU**.

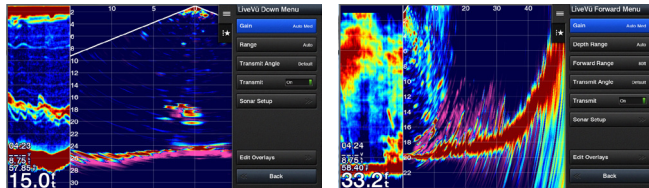

**Gain:** Controls the level of detail and noise shown on the sonar screen.

If you want to see the highest intensity signal returns on the screen, you can lower the gain to remove lower intensity returns and noise. If you want to see all return information, you can increase the gain to see more information on the screen. This also increases noise, and can make it more difficult to recognize actual returns.

**Range / Depth Range:** Adjusts the range of the depth scale.

Allowing the device to adjust the range automatically keeps the bottom within the lower portion of the sonar screen, and can be useful for tracking a bottom that has minimal or moderate terrain changes.

Manually adjusting the range enables you to view a specified range, which can be useful for tracking a bottom that has large terrain changes, such as a drop-offs or cliffs. The bottom can appear on the screen as long as it appears within the range you have set.

**Forward Range:** Adjusts the range of the forward scale.

Allowing the device to adjust the range automatically adjusts the forward scale in relation to the depth.

Manually adjusting the range enables you to view a specified range. The

bottom can appear on the screen as long as it appears within the range you have set. Manually reducing this option can reduce the effectiveness of the FrontVü Alarm, reducing your reaction time to low depth readings.

**Transmit Angle:** Adjusts the focus of the transducer to the port or starboard side. This is available only with RealVü capable Panoptix FrontVü transducers, such as the PS30, PS31, and PS60.

**Transmit:** Stops the transducer from transmitting.

**FrontVü Alarm:** Sets an alarm to sound when the depth in front of the vessel is less than the specified value. This is available only with Panoptix FrontVü transducers.

**Sonar Setup:** Adjusts the setup of the transducer and the appearance of the sonar returns.

**Edit Overlays:** Adjusts the data shown on the screen.

### **Setting the LiveVü and FrontVü Transducer Transmit Angle**

This feature is available only with Panoptix LiveVü and FrontVü transducers.

You can change the transducer transmit angle to aim the transducer at a particular area of interest. For example, you might aim the transducer to follow a bait ball or focus on a tree as you pass it.

- 1 From a LiveVü or FrontVü sonar view, select **MENU > Transmit Angle**.
- 2 Select an option.

### **Setting the FrontVü Depth Alarm**



The FrontVü depth alarm is a tool for situational awareness only, and may not prevent groundings in all circumstances. It is the obligation of the vessel operator to ensure safe operation of the vessel.

This alarm is available only with Panoptix FrontVü transducers.

You can set an alarm to sound when the depth is below a specified level. For best results, you should set the bow offset when using the front collision

alarm.

- 1 From the FrontVü sonar view, select **MENU > FrontVü Alarm**.
- 2 Select **On**.
- 3 Enter the depth at which the alarm is triggered, and select **Done**.

On the FrontVü screen, a depth line shows the depth at which the alarm is set. The line is green when you are in a safe depth. The line turns yellow when you are going faster than the forward range gives you time to react (10 seconds). It turns red and sounds an alarm when the system detects an obstruction or the depth is less than the entered value.

### CAUTION

The ability to effectively avoid running aground with FrontVü sonar decreases as your speed rises above 8 knots.

## RealVü Appearance Settings

From a RealVü sonar view, select **MENU > Sonar Setup > Appearance**.

**Point Colors:** Selects the color palette.

**Bottom Colors:** Sets the color of the bottom to either one of the color palette, or a brown color.

**Bottom Style:** Sets the style for the bottom. When you are in deep water, you can select the Points option and manually set the range to a shallower value.

**Color Key:** Shows a legend of the depths the colors represent.

## LiveVü and FrontVü Appearance Settings

From a LiveVü or FrontVü Panoptix sonar view, select **MENU > Sonar Setup > Appearance**.

**Color Scheme:** Sets the color palette.

**Color Gain:** Adjusts the intensity of colors shown on the screen. You can select a higher color gain value to see targets higher in the water

column. A higher color gain value also allow you to differentiate low intensity returns higher in the water column, but this causes a loss in the differentiation of the returns at the bottom. You can select a lower color gain value when targets are near the bottom, to help you distinguish between targets and high intensity returns such as sand, rock, and mud.

**Trails:** Sets the how long the trails appear on the screen. The trails show the movement of the target.

**Bottom Fill:** Colors the bottom brown to distinguish it from the water returns.

**Grid Overlay:** Shows a grid of range lines.

**Scroll History:** Shows the sonar history in a traditional sonar view.

## RealVü Appearance Settings

From a RealVü sonar view, select **MENU > Sonar Setup > Appearance**.

**Point Colors:** Sets a different color palette for the sonar return points.

**Bottom Colors:** Sets the color scheme for the bottom.

**Bottom Style:** Sets the style for the bottom. When you are in deep water, you can select the Points option and manually set the range to a shallower value.

**Color Key:** Shows a legend of the depths the colors represent.

## Panoptix Transducer Installation Settings

From a Panoptix sonar view, select **MENU > Sonar Setup > Installation**.

**Install Depth:** Sets the depth below the water line where the Panoptix transducer is mounted. Entering the actual depth at which the transducer is mounted results in a more accurate visual presentation of what is in the water.

**Bow Offset:** Sets the distance between the bow and the forward view Panoptix transducer installation location. This allows you to view the forward distance from the bow instead of the transducer location. This applies to Panoptix transducers in the FrontVü, LiveVü Forward, and

RealVü 3D Forward sonar views.

**Beam Width:** Sets the width of the down view Panoptix transducer beam. Narrow beam widths allow you to see deeper and farther. Wider beam widths allow you to see more coverage area. This applies to Panoptix transducers in the FrontVü, LiveVü Down, and LiveVü Forward sonar views.

**Use AHRS:** Enables the internal attitude heading and reference system (AHRS) sensors to detect the installation angle of the Panoptix transducer automatically. When this setting is turned off, you can enter the specific installation angle for the transducer using the Pitch Angle setting. Many forward view transducers are installed at a 45-degree angle and down view transducers are installed at a zero-degree angle.

**Flipped:** Sets the orientation of the Panoptix sonar view when the down view transducer is installed with the cables pointing toward the port side of the boat.

This applies to Panoptix transducers in the LiveVü Down, RealVü 3D Down, and RealVü 3D Historical sonar views.

**Calibrate Compass:** Calibrates the internal compass in the Panoptix transducer.

This applies to Panoptix transducers with an internal compass, such as the PS21-TR transducer.

**Restore Sonar Defaults:** Restores the sonar settings to the factory default values.

### **Setting the Bow Offset**

For forward view Panoptix transducers, you can enter a bow offset to compensate the forward distance readings for the transducer installation location. This allows you to view the forward distance from the bow instead of the transducer installation location.

This feature applies to Panoptix transducers in the FrontVü, LiveVü Forward, and RealVü 3D Forward sonar views.

1 Measure the horizontal distance ① from the transducer to the bow.

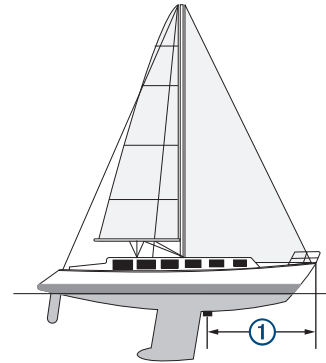

2 From an applicable sonar view, select **MENU > Sonar Setup > Installation > Bow Offset**.

3 Enter the distance measured, and select **Done**.

On the applicable sonar view, the forward range shifts by the distance you entered.

# Radar

## ⚠ WARNING

The marine radar transmits microwave energy that has the potential to be harmful to humans and animals. Before beginning radar transmission, verify that the area around the radar is clear. The radar transmits a beam approximately 12° above and below a line extending horizontally from the center of the radar.

When the radar is transmitting, do not look directly at the antenna at close range; eyes are the most sensitive part of the body to electromagnetic energy.

When you connect your compatible AQUAMAP to an optional Garmin marine radar, such as a GMR™ Fantom™ 6 radar or a GMR 24 xHD, you can view more information about your surroundings.

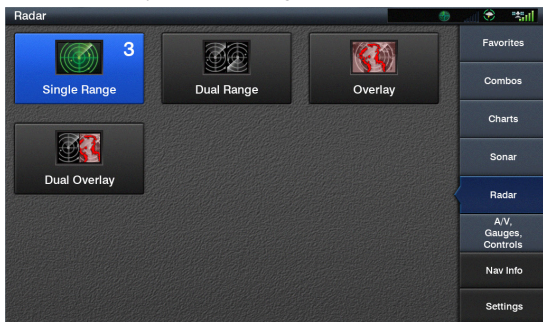

The radar transmits a narrow beam of microwave energy as it rotates to a 360° pattern. When the transmitted energy contacts a target, some of that energy is reflected back to the radar.

## Transmitting Radar Signals

**NOTE:** As a safety feature, the radar enters standby mode after it warms

up. This gives you an opportunity to verify the area around the radar is clear before beginning radar transmission.

- 1 With the AQUAMAP off, connect your radar as described in the radar installation instructions.
- 2 Turn on the AQUAMAP.  
If necessary, the radar warms up and a countdown alerts you when the radar is ready.
- 3 Select **Radar**.
- 4 A countdown message appears while the radar is starting up.
- 5 Select **MENU > Transmit Radar**.

## Stopping the Transmission of Radar Signals

From a radar screen, select **MENU > Radar to Standby**.

**TIP:** Select  **> Radar to Standby** from any screen to quickly stop radar transmission.

## Setting Up the Timed Transmit Mode

To help conserve power, you can set up time intervals in which the radar will transmit and not transmit (standby) signal transmissions.

**NOTE:** This feature is not available in dual radar modes.

- 1 From a radar screen, select **MENU > Radar Options > Timed Transmit**.
- 2 Select **Timed Transmit** to enable the option.
- 3 Select **Stdbby Time**, enter the time interval between radar signal transmissions, and select **Done**.
- 4 Select **Transmit Time**, enter the duration of each radar signal transmission, and select **Done**.

## Enabling and Adjusting a Radar No Transmit Zone

You can indicate areas within which the radar scanner does not transmit

signals.

**NOTE:** GMR Fantom and xHD2 radar models support two no-transmit zones. Other GMR radar models support one no-transmit zone.

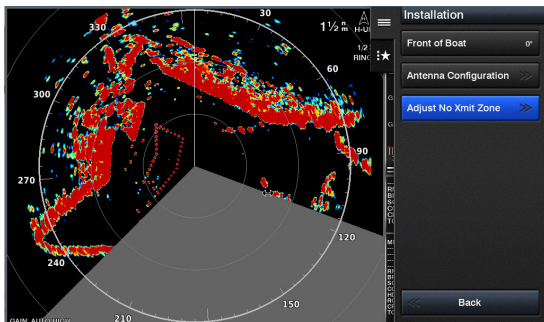

- 1 From a radar screen, select **MENU > Radar Setup > Installation > Enable No Xmit Zone.**

The no-transmit zone is indicated by a shaded area on the radar screen.

- 2 Select **Adjust No Transmit Zone > Move No Transmit Zone.**
- 3 Select **Angle 1**, and select the new location for the first angle.
- 4 Select **Angle 2**, and select the new location for the second angle.
- 5 Select **Done.**

## Adjusting the Radar Range

The range of the radar signal indicates the length of the pulsed signal transmitted and received by the radar. As the range increases, the radar transmits longer pulses in order to reach distant targets. Closer targets, especially rain and waves, also reflect the longer pulses, which can add noise to the radar screen. Viewing information about longer-range targets can also decrease the amount of space available on the radar screen for viewing information about shorter-range targets.

- 1 From a radar screen, press the knob.
- 2 If necessary, press **FOCUS** to select a radar view.
- 3 Turn the knob to increase or decrease the range.

## Tips for Selecting a Radar Range

- Determine what information you need to see on the Radar screen. For example, do you need information about nearby weather conditions or targets and traffic, or are you more concerned about distant weather conditions?
- Assess the environmental conditions where the radar is being used. Especially in inclement weather, longer-range radar signals can increase the clutter on the Radar screen and make it more difficult to view information about shorter-range targets. In rain, shorter-range radar signals can enable you to view information about nearby objects more effectively, if the rain clutter setting is configured optimally.
- Select the shortest effective range, given your reason for using radar and the present environmental conditions.

## Marking a Waypoint on the Radar Screen

- 1 From a radar screen, select a location.
- 2 Select **New Waypoint.**

## MotionScope™ Doppler Radar Technology

The GMR Fantom radar uses the Doppler effect to detect and highlight moving targets to help you avoid potential collisions, find flocks of birds, and track weather formations. The Doppler effect is the frequency shift in the radar echo due to the relative motion of the target. This allows for instant detection of any targets moving toward or away from the radar.

The MotionScope feature highlights the moving targets on the radar display so you can navigate around other boats or severe weather, or toward fishing spots where birds are feeding at the surface.

The moving targets are color-coded so you can tell at a glance which targets are heading your way and which are heading away from you. On most color schemes, green indicates the target is moving away from you and red indicates the target is moving toward you.

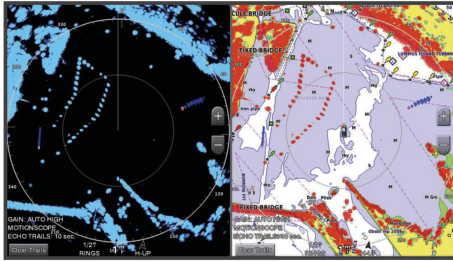

## Enabling a Guard Zone

You can enable a guard zone to alert you when anything comes within a specified area around your boat.

**NOTE:** This feature is not available in dual radar modes.

From a radar screen, select **MENU > Radar Options > Enable Guard Zone**.

## Defining a Circular Guard Zone

Before you can define the boundaries of the guard zone, you must enable a guard zone.

You can define a circular guard zone that completely surrounds your boat.

- 1 From a radar screen, select **MENU > Radar Options > Adjust Guard Zone > Adjust Guard Zone > Circle**.
- 2 Select the location of the outer guard zone circle.
- 3 Select the location of the inner guard zone circle to define the width of the guard zone.

## Defining a Partial Guard Zone

You can define the boundaries of a guard zone that does not completely surround your boat.

- 1 From a radar screen, select **MENU > Radar Options > Adjust Guard Zone > Adjust Guard Zone > Corner 1**.
- 2 Select the location of guard-zone corner ①.

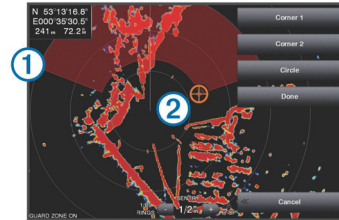

- 3 Select **Corner 2**.
- 4 Select the location of guard-zone corner ② to define the width of the guard zone.
- 5 Select **Done**.

## Disabling a Guard Zone

You can disable a guard zone.

From a radar screen, select **MENU > Radar Options > Adjust Guard Zone > Disable Guard Zone**.





The guard zone configuration is saved, so you can enable it again when needed.

## MARPA

Mini-automatic radar plotting aid (MARPA) enables you to identify and track targets and is primarily used for collision avoidance. To use MARPA, you assign a MARPA tag to a target. The radar system automatically tracks the

tagged object and provides you with information about the object, including the range, bearing, speed, GPS heading, nearest approach, and time to nearest approach. MARPA indicates the status of each tagged object (acquiring, lost, tracking, or dangerous), and the AQUAMAP can sound a collision alarm if the object enters your safe zone.

## MARPA Targeting Symbols

	Acquiring a target. Concentric, dashed green rings radiate from the target while the radar is locking onto it.
	Target has been acquired. A solid green ring indicates the location of a target that the radar has locked onto. A dashed green line attached to the circle indicates the projected course over ground or the GPS heading of the target.
	Dangerous target is in range. A red ring flashes from the target while an alarm sounds and a message banner appears. After the alarm has been acknowledged, a solid red dot with a dashed red line attached to it indicates the location and the projected course over ground or the GPS heading of the target. If the safe- zone collision alarm has been set to Off, the target flashes, but the audible alarm does not sound and the alarm banner does not appear.
	Target has been lost. A solid green ring with an X through it indicates that the radar could not lock onto the target.
	Closest point of approach and time to closest point of approach to a dangerous target.

## Assigning a MARPA Tag to an Object

Before you can use MARPA, you must have a heading sensor connected and an active GPS signal. The heading sensor must provide the NMEA 2000 parameter group number (PGN) 127250 or the NMEA 0183 HDM or HDG output sentence.

- 1 From a radar screen, select an object or location.
- 2 Select **Acquire Target > MARPA Target**.

## Removing a MARPA Tag from a Targeted Object

- 1 From a radar screen, select a MARPA target.
- 2 Select **MARPA Target > Remove**.

## Viewing Information about a MARPA-tagged Object

You can view the range, bearing, speed, and other information about a MARPA-tagged object.

- 1 From a radar screen, select a targeted object.
- 2 Select **MARPA Target**.

## Viewing a List of AIS and MARPA Threats

From any radar screen or the radar overlay, you can view and customize the appearance of a list of AIS and MARPA threats.

- 1 From a radar screen, select **MENU > Other Vessels > List > Show**.
- 2 Select the type of threats to include in the list.

## Showing AIS Vessels on the Radar Screen

AIS requires the use of an external AIS device and active transponder signals from other vessels.

You can configure how other vessels appear on the Radar screen. If any setting (except the AIS display range) is configured for one radar mode, the setting is applied to every other radar mode. The details and projected heading settings configured for one radar mode are applied to every other radar mode and to the Radar overlay.

- 1 From a radar screen or the radar overlay, select **MENU > Other Vessels > Display Setup**.
- 2 Select an option:
  - To set the distance from your location within which AIS vessels appear, select **Display Range**, and select a distance.
  - To set the relative speed within which AIS vessels appear, select

**Display Speed**, and select a speed.

- To show details about AIS-activated vessels, set **Details** to **Show**.
- To set the projected heading time for AIS-activated vessels, select **Proj. Heading**, and enter the time.
- To show outlines of vessels, set **Vessel Outline** to **Show**.

## VRM and EBL

The variable range marker (VRM) and the electronic bearing line (EBL) measure the distance and bearing from your boat to a target object. On the Radar screen, the VRM appears as a circle that is centered on the present location of your boat, and the EBL appears as a line that begins at the present location of your boat and intersects the VRM. The point of intersection is the target of the VRM and the EBL.

### Showing the VRM and the EBL

From a radar screen, select **MENU > Radar Options > Show VRM/EBL**.

### Adjusting the VRM and the EBL

Before you can adjust the VRM and the EBL, you must show them on the Radar screen.

You can adjust the diameter of the VRM and the angle of the EBL, which moves the intersection point of the VRM and the EBL. The VRM and the EBL configured for one mode are applied to all other radar modes.

- 1 From a radar screen, use the knob to adjust the VRM.
- 2 Use the arrow keys to adjust the cursor.
- 3 Select **SELECT > Drop VRM/EBL** to set the VRM and EML.

### Measuring the Range and Bearing to a Target Object

- 1 From a radar screen, select the target location.
- 2 Select **Measure Distance**.

The range and the bearing to the target location appear in the upper-left corner of the screen.

## Professional Mode

Professional mode provides additional advanced data on the screen and allows you to track two MARPA targets and two AIS targets simultaneously on the lower right corner of the screen.

- 1 From a radar screen, select **MENU > Edit Overlays**.
- 2 Select **Prof. Mode > On**.

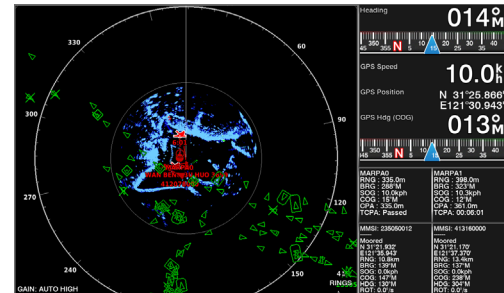

## Radar Overlay

When you connect your AQUAMAP to an optional Garmin marine radar, you can use overlay radar information on the Nav. chart or on the Fishing chart.

Data appears on the radar overlay based on the most recently used radar mode and all settings configurations applied to the radar overlay are also applied to the last-used radar mode.

### Radar Overlay and Chart Data Alignment

When using the Radar overlay, the AQUAMAP aligns radar data with chart data based on the boat heading, which is based by default on data from a magnetic heading sensor connected using a NMEA 0183 or NMEA 2000

network. If a heading sensor is not available, the boat heading is based on GPS tracking data.

GPS tracking data indicates the direction in which the boat is moving, not the direction in which the boat is pointing. If the boat is drifting backward or sideways due to a current or wind, the Radar overlay may not perfectly align with the chart data. This situation should be avoided by using boat- heading data from an electronic compass.

If the boat heading is based on data from a magnetic heading sensor or an automatic pilot, the heading data could be compromised due to incorrect setup, mechanical malfunction, magnetic interference, or other factors. If the heading data is compromised, the Radar overlay may not align perfectly with the chart data.

## Echo Trails

The echo trails feature enables you to track the movement of vessels on the radar display. As a vessel moves, you can see a faint trail ① of the vessel's wake. You can change the length of time the trail is displayed

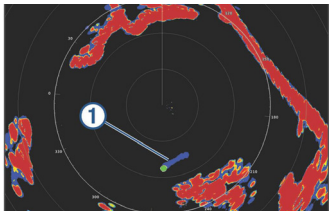

**NOTE:** Depending on the radar in use, the settings configured for use in one radar mode may or may not be applied to other radar modes or to the radar overlay.

**NOTE:** This feature is not available on xHD open array or HD/HD+ radome models.

## Turning on Echo Trails

From a radar screen, select **MENU > Radar Options > Echo Trails > Display**.

## Adjusting the Length of the Echo Trails

- 1 From a radar screen or the radar overlay, select **MENU > Radar Options > Echo Trails > Time**.
- 2 Select the length of the trail.

## Clearing the Echo Trails

You can remove the echo trails from the radar screen to reduce the clutter on the screen.

From a radar screen, select **MENU > Radar Options > Echo Trails > Clear Trails**.

## Optimizing the Radar Display

You can adjust the radar display settings for reduced clutter and increased accuracy.

**NOTE:** You can optimize the radar display for each radar mode.

**NOTE:** Depending on the radar in use, the setting configured for use in one radar mode may or may not be applied to other radar modes or to the Radar overlay.

## Adjusting Gain on the Radar Screen Automatically

The automatic gain setting for each radar mode is optimized for that mode, and may differ from the automatic gain setting used for another mode.

**NOTE:** Not all options are available on all radar models.

- 1 From a radar screen or the radar overlay, select **MENU > Gain**.
- 2 Select an option:
  - To adjust the gain automatically for changing conditions, select **Auto**

## Low or Auto High.

- To adjust the gain automatically to show birds over the surface of the water, select **Auto Bird**.

**NOTE:** This option is not available on xHD open array or HD/HD+ radome models.

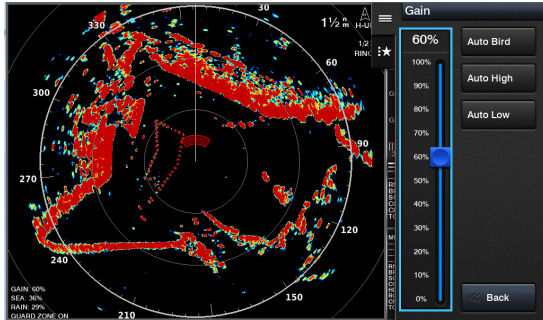

## Adjusting Gain on the Radar Screen Manually

For optimal radar performance, you can manually adjust the gain.

- From a radar screen or the radar overlay, select **MENU > Gain**.
- Turn the knob clockwise to raise the gain, until light speckles appear across the Radar screen.

Data on the Radar screen is refreshed every few seconds. As a result, the effects of manually adjusting the gain may not appear instantly. Adjust the gain slowly.

- Turn the knob counterclockwise to lower the gain until the speckles disappear.
- If boats, land, or other targets are within range, turn the knob counterclockwise to lower the gain until the targets begin to blink.
- Turn the knob clockwise to raise the gain until the boats, land, or other targets appear steadily lit on the Radar screen.

6 Minimize the appearance of nearby large objects, if necessary.

7 Minimize the appearance of side-lobe echoes, if necessary.

## Minimizing Nearby Large-Object Interference

Nearby targets of significant size, such as jetty walls, can cause a very bright image of the target to appear on the Radar screen. This image can obscure smaller targets located near it.

- From a radar screen or the radar overlay, select **MENU > Gain**.
- Select **Down** to lower the gain until the smaller targets are clearly visible on the Radar screen.

Reducing the gain to eliminate nearby large-object interference may cause smaller or distant targets to blink or disappear from the Radar screen.

## Minimizing Side-Lobe Interference on the Radar Screen

Side-lobe interference may appear to streak outward from a target in a semi-circular pattern. Side-lobe effects can be avoided by reducing the gain or reducing the radar range.

- From a radar screen or the radar overlay, select **MENU > Gain**.
- Select **Down** to lower the gain until the semi-circular, streaked pattern disappears from the Radar screen.

Reducing the gain to eliminate side-lobe interference may cause smaller or distant targets to blink or disappear from the Radar screen.

## Adjusting Sea Clutter on the Radar Screen Automatically

Radar echos reflected from the sea waves could disturb the true targets, and showing on the central area of the radar screen with a lot of random echo signals which known as "sea clutter". The higher sea waves or the higher the radar antenna installing on the vessel above the water, the more clutter will extend. Sea Clutter appears on the screen as many small echoes which might affect the radar performance.

You can set the AQUAMAP to automatically adjust the appearance of Sea

Clutter caused by choppy sea conditions.

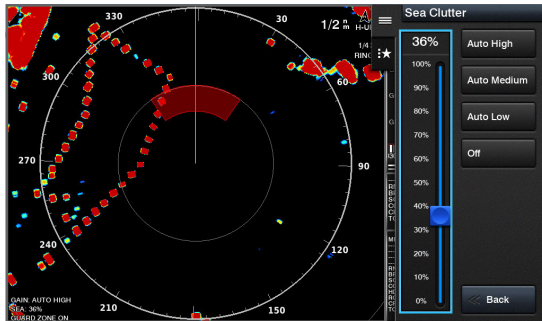

**NOTE:** Not all options and settings are available on all radar and AQUAMAP models.

- 1 From a radar screen or the radar overlay, select **MENU > Sea Clutter**.
- 2 Select **Presets** or **Auto**.
- 3 Select a setting that reflects the present sea conditions.

When using a compatible radar model, the AQUAMAP adjusts the sea clutter based on the sea conditions automatically.

### Adjusting Sea Clutter on the Radar Screen Manually

You can adjust the appearance of clutter caused by choppy sea conditions. The sea clutter setting affects the appearance of nearby clutter and targets more than it affects the appearance of distant clutter and targets. A higher sea clutter setting reduces the appearance of clutter caused by nearby waves, but it can also reduce or eliminate the appearance of nearby targets.

- 1 From a radar screen or the radar overlay, select **MENU > Sea Clutter**.
- 2 Turn the knob to adjust the appearance of sea clutter until other targets are clearly visible on the radar screen.

Clutter caused by sea conditions may still be visible.

### Adjusting Rain Clutter on the Radar Screen

The radar antenna's vertical beamwidth is designed to see the water surface's targets even during the vessel is rolling. By this design the radar also will detect the rain clutter such as rain, snow and hail etc in the same manner as the normal targets.

You can adjust the appearance of Rain Clutter caused by rain. Reducing the radar range also can minimize rain clutter.

The rain clutter setting affects the appearance of nearby rain clutter and targets more than it affects the appearance of distant rain clutter and targets. A higher rain clutter setting reduces the appearance of clutter caused by nearby rain, but it can also reduce or eliminate the appearance of nearby targets.

- 1 From a radar screen, select **MENU > Radar Options > Rain Clutter**.
- 2 Turn the knob to decrease or increase the appearance of nearby rain clutter until other targets are clearly visible on the radar screen.

Clutter caused by rain may still be visible.

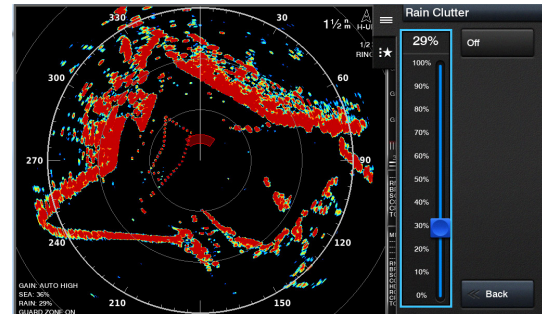

### Reducing Cross Talk Clutter on the Radar Screen

You can reduce the appearance of clutter caused by interference from another nearby radar source, when the cross talk reject setting is on.

From a Radar screen or the Radar overlay, select **MENU > Radar Setup > Crosstalk Rej.**

## Radar Options Menu

From a radar screen, select **MENU > Radar Options.**

**MotionScope™:** Uses the Doppler effect to detect and highlight moving targets to help you avoid potential collisions, find flocks of birds, and track weather formations. This option is only available on Fantom models.

**Pulse Exp.:** Increases the duration of the transmit pulse, which helps maximize the energy directed toward targets. This helps to enhance the detection and identification of targets. This option is not available on xHD open array or HD/HD+ radome models.

**Target Size:** Adjusts the size of targets, by adjusting the pulse compression processing. Select smaller targets for a sharp, high resolution radar image. Select larger targets to display larger echos for point targets, like boats and buoys. This option is only available on Fantom models.

**Echo Trails:** Enables you to track the movement of vessels on the radar screen. This option is not available on xHD open array or HD/HD+ radome models.

**Rain Clutter:** Reduces the clutter caused by rain.

**Show VRM/EBL:** Shows the variable range marker (VRM) circle and the electronic bearing line (EBL) to allow you to measure the distance and bearing from your boat to a target object.

**Enable Guard Zone:** Sets a safe zone around your boat and sounds an alarm when anything enters the zone.

**Timed Transmit:** Helps conserve power by transmitting radar signals at set intervals.

## Radar Setup Menu

From a radar screen, select **MENU > Radar Setup.**

**Source:** Selects the radar source when more than one radar is connected to the network.

**Chart Display:** Shows the chart under the radar image. When enabled, the Chart Setup menu appears.

**Orientation:** Sets the perspective of the radar display.

**Crosstalk Rej.:** Reduces the appearance of clutter caused by interference from another nearby radar source.

**Rotation Spd.:** Sets the preferred speed at which the radar rotates. The High Speed option can be used to increase the refresh rate. In some situations, the radar automatically rotates at the normal speed to improve detection, for example, when a longer range is selected or when MotionScope or Dual range is used.

**Appearance:** Sets the color scheme, look-ahead speed, and navigation appearance.

**Installation:** Allows you to configure the radar for the installation, such as setting the front of the boat and the antenna park position.

## Radar Appearance Settings

From a radar screen, select **MENU > Radar Setup > Appearance.**

**NOTE:** These settings do not apply to the radar overlay.

**Bkgd. Color:** Sets the color for the background.

**Foreground Clr.:** Sets the color scheme for the radar returns.

**Look-Ahd. Spd.:** Shifts your present location toward the bottom of the screen automatically as your speed increases. Enter your top speed for the best results.

**Heading Line:** Shows an extension from the bow of the boat in the direction of travel on the radar screen.

**Range Rings:** Shows the range rings that help you to visualize distances on the radar screen.

**Bearing Ring:** Shows a bearing relative to your heading or based on a north

reference, to help you determine the bearing to an object shown on the radar screen.

**Nav Lines:** Shows the navigation lines that indicate the course you have set using Route To, Auto Guidance, or Go To.

**Marks & Waypo:** Shows marks and waypoints on the radar screen.

## Radar Installation Settings

**Front of Boat:** Compensates for the physical location of the radar when it is not on the boat axis.

**Antenna Configuration:** Sets the radar antenna size and sets the position in which the radar stops.

**Enable No Xmit Zone:** Sets the area in which the radar does not transmit signals.

### *Front-of-Boat Offset*

The front-of-boat offset compensates for the physical location of the radar scanner on a boat, if the radar scanner does not align with the bow-stern axis.

### *Measuring the Potential Front-of-Boat Offset*

The front-of-boat offset compensates for the physical location of the radar scanner on a boat, if the radar scanner does not align with the bow-stern axis.

- 1 Using a magnetic compass, take an optical bearing of a stationary target located within viewable range.
- 2 Measure the target bearing on the radar.
- 3 If the bearing deviation is more than +/- 1°, set the front-of-boat offset.

### *Setting the Front-of-Boat Offset*

Before you can set the front-of-boat offset, you must measure the potential front-of-boat offset.

The front-of-boat offset setting configured for use in one radar mode is applied to every other radar mode and to the Radar overlay.

- 1 From a Radar screen or the Radar overlay, select **MENU > Radar Setup > Installation > Front of Boat**.
- 2 Turn the knob to adjust the offset.

### *Setting a Custom Park Position*

If you have more than one radar on your boat, you must be viewing the radar screen for the radar you want to adjust.

By default, the antenna is stopped perpendicular to the pedestal when it is not spinning. You can adjust this position.

- 1 From the radar screen, select **MENU > Radar Setup > Installation > Antenna Configuration > Park Position**.
- 2 Use the slider bar to adjust the position of the antenna when stopped, and select **BACK**.

## Selecting a Different Radar Source

- 1 Select an option:
  - From a radar screen or the radar overlay, select **MENU > Radar Setup > Source**.
  - Select **Settings > Communications > Preferred Sources > Radar**.
- 2 Select the radar source.

# Nav Info

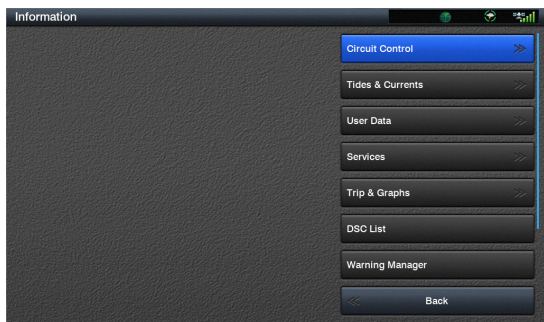

## Tide, Current, and Celestial Information

### Tide Station Information

You can view information about a tide station for a specific date and time, including the tide height, and when the next high and low tides will occur. By default, the AQUAMAP shows tide information for the most recently viewed tide station, present date, and past hour.

Select **NAV INFO > Tides & Currents > Tides**.

### Current Station Information

**NOTE:** Current station information is available with certain detailed maps.

You can view information about a current station for a specific date and time, including the current speed and level of the current. By default, the AQUAMAP shows current information for the most recently viewed current station and for the present date and time.

Select **NAV INFO > Tides & Currents > Currents**.

### Celestial Information

You can view information about sunrise, sunset, moonrise, moonset, moon phase, and the approximate sky view location of the sun and moon. The center of the screen represents the sky overhead, and the outermost rings represent the horizon. By default, the AQUAMAP shows celestial information for the present date and time.

Select **NAV INFO > Tides & Currents > Celestial**.

### Viewing Tide Station, Current Station, or Celestial Information for a Different Date

- 1 Select **NAV INFO > Tides & Currents**.
- 2 Select **Tides, Currents, or Celestial**.
- 3 Select an option.
  - To view information for a different date, select **Change Date > Manual**, and enter a date.
  - To view information for today, select **Change Date > Current Date and Time**.
  - If available, to view information for the day after the date shown, select **Next Day**.
  - If available, to view information for the day before the date shown, select **Previous Day**.

### Viewing Information for a Different Tide or Current Station

- 1 Select **NAV INFO > Tides & Currents**.
- 2 Select **Tides** or **Currents**.
- 3 Select **Nearby Stations**.
- 4 Select a station.

## Viewing Almanac Information from the Nav. chart

- 1 From a chart or 3D chart view, select a location.
- 2 Select **Information**.
- 3 Select **Tides, Currents, or Celestial**.

## Sharing and Managing User Data

Before you can share and manage user data, you must have a memory card installed in the AQUAMAP. This device supports up to a 32 GB memory card, formatted to FAT32.

### Copying Waypoints, Routes, and Tracks from HomePort to AQUAMAP

Before you can copy data to the AQUAMAP, you must have the latest version of the HomePort software program loaded on your computer and a memory card installed in the AQUAMAP.

Copy the data from HomePort to the prepared memory card.

For more information, see the HomePort help file.

### Selecting a File Type for Third-Party Waypoints and Routes

You can import and export waypoints and routes from third-party devices.

- 1 Insert a memory card into the card slot.
- 2 Select **NAV INFO > User Data > Data Transfer > File Type**.
- 3 Select **GPX**.

To transfer data with Garmin devices again, select the ADM file type.

### Copying Data from a Memory Card

- 1 Insert a memory card into a card slot.
- 2 Select **NAV INFO > User Data > Data Transfer**.
- 3 If necessary, select the memory card to copy data to.

- 4 Select an option:
  - To transfer data from the memory card to the AQUAMAP and combine it with existing user data, select **Merge from Card**.
  - To transfer data from the memory card to the AQUAMAP and overwrite existing user data, select **Replace from Card**.
- 5 Select the file name.

### Copying Waypoints, Routes, and Tracks to a Memory Card

- 1 Insert a memory card into the card slot.
- 2 Select **NAV INFO > User Data > Data Transfer > Save to Card**.
- 3 If necessary, select the memory card to copy data to.
- 4 Select an option:
  - To create a new file, select **Add New File**, and enter a name.
  - To add the information to an existing file, select the file from the list.

### Copying Built-In Maps to a Memory Card

You can copy maps from the AQUAMAP to a memory card for use with HomePort.

- 1 Insert a memory card into the card slot.
- 2 Select **NAV INFO > User Data > Data Transfer**.
- 3 Select **Copy Built-In Map**.

### Backing Up Data to a Computer

- 1 Insert a memory card into the card slot.
- 2 Select **NAV INFO > User Data > Data Transfer > Save to Card**.
- 3 Select a file name from the list, or select **Add New File**.
- 4 Select **Save to Card**.
- 5 Remove the memory card, and insert it into a card reader attached to a computer.

- 6 Open the Garmin\UserData folder on the memory card.
- 7 Copy the backup file on the card and paste it to any location on the computer.

## Restoring Backup Data to AQUAMAP

- 1 Insert a memory card into a card reader that is attached to the computer.
- 2 Copy a backup file from the computer to the memory card, into a folder named Garmin\UserData.
- 3 Insert a memory card into the card slot.
- 4 Select **NAV INFO > User Data > Data Transfer > Replace from Card**.

## Saving System Information to a Memory Card

You can save system information to a memory card as a troubleshooting tool. A product support representative may ask you to use this information to retrieve data about the network.

- 1 Insert a memory card into the card slot.
- 2 Select **Settings > System > System Information > Garmin Devices > Save to Card**.
- 3 If necessary, select the memory card to save system information to.
- 4 Remove the memory card.

## Digital Selective Calling

### Networked AQUAMAP and VHF Radio Functionality

If you have a NMEA 0183 VHF radio or a NMEA 2000 VHF radio connected to your AQUAMAP, these features are enabled.

- The AQUAMAP can transfer your GPS position to your radio. If your radio is capable, GPS position information is transmitted with DSC calls.
- The AQUAMAP can receive digital selective calling (DSC) distress and position information from the radio.

• The AQUAMAP can track the positions of vessels sending position reports. If you have a Garmin NMEA 2000 VHF radio connected to your AQUAMAP, these features are also enabled.

- The AQUAMAP allows you to quickly set up and send individual routine call details to your Garmin VHF radio.
- When you initiate a man-overboard distress call from your radio, the AQUAMAP shows the man-overboard screen and prompts you to navigate to the man-overboard point.
- When you initiate a man-overboard distress call from your AQUAMAP, the radio shows the Distress Call page to initiate a man-overboard distress call.

## Turning On DSC

Select **Settings > Other Vessels > DSC**.

## DSC List

The DSC list is a log of the most recent DSC calls and other DSC contacts you have entered. The DSC list can contain up to 100 entries. The DSC list shows the most recent call from a boat. If a second call is received from the same boat, it replaces the first call in the call list.

### Viewing the DSC List

Before you can view the DSC list, the AQUAMAP must be connected to a VHF radio that supports DSC.

Select **NAV INFO > DSC List**.

### Adding a DSC Contact

You can add a vessel to your DSC list. You can make calls to a DSC contact from the AQUAMAP.

- 1 Select **NAV INFO > DSC List > Add Contact**.
- 2 Enter the Maritime Mobile Service Identity (MMSI) of the vessel.

3 Enter the name of the vessel.

### Incoming Distress Calls

If your compatible AQUAMAP and VHF radio are connected using NMEA 0183 or NMEA 2000, your AQUAMAP alerts you when your VHF radio receives a DSC distress call. If position information was sent with the distress call, that information is also available and recorded with the call.

 designates a distress call in the DSC list and marks the position of the vessel on the Nav. chart at the time of the DSC distress call.

#### *Navigating to a Vessel in Distress*

 designates a distress call in the DSC list and marks the position of a vessel on the Nav. chart at the time of the DSC distress call.

- 1 Select **NAV INFO > DSC List**.
- 2 Select a position-report call.
- 3 Select **Review > Navigate To**.
- 4 Select **Go To** or **Route To**.

#### *Man-Overboard Distress Calls Initiated from a VHF Radio*

When the AQUAMAP is connected to a compatible VHF radio with NMEA 2000, and you initiate a man-overboard DSC distress call from the radio, the AQUAMAP shows the man-overboard screen and prompts you to navigate to the man-overboard point. If you have a compatible autopilot system connected to the network, the AQUAMAP prompts you to start a Williamson's turn to the man-overboard point.

If you cancel the man-overboard distress call on the radio, the AQUAMAP screen prompting you to activate navigation to the man-overboard location disappears.

#### *Man-Overboard and SOS Distress Calls Initiated from the AQUAMAP*

When your AQUAMAP is connected to a Garmin NMEA 2000 compatible

radio and you mark an SOS or man-overboard location, the radio shows the Distress Call page so you can quickly initiate a distress call.

For information on placing distress calls from your radio, see the VHF radio owner's manual.

### Position Tracking

When you connect the AQUAMAP to a VHF radio using NMEA 0183, you can track vessels that send position reports.

This feature is also available with NMEA 2000, when the vessel sends the correct PGN data (PGN 129808; DSC Call Information).

Every position report call received is logged in the DSC list.

#### *Viewing a Position Report*

- 1 Select **NAV INFO > DSC List**.
- 2 Select a position-report call.
- 3 Select **Review**.
- 4 Select an option:
  - To switch to a Nav. chart marking the location, select **Next Page**.
  - To view the position report details, select **Previous Page**.

#### *Navigating to a Tracked Vessel*

- 1 Select **NAV INFO > DSC List**.
- 2 Select a position-report call.
- 3 Select **Review > Navigate To**.
- 4 Select **Go To** or **Route To**.

#### *Creating a Waypoint at the Position of a Tracked Vessel*

- 1 Select **NAV INFO > DSC List**.
- 2 Select a position-report call.

### 3 Select **Review** > **New Waypoint**.

#### *Editing Information in a Position Report*

##### 1 Select **NAV INFO** > **DSC List**.

##### 2 Select a position-report call.

##### 3 Select **Review** > **Edit**.

- To enter the name of the vessel, select **Name**.
- To select a new symbol, select **Symbol**, if available.
- To enter a comment, select **Comment**.
- To show a trail line for the vessel if your radio is tracking the position of the vessel, select **Trail**.
- To select a color for the trail line, select **Trail Line**.

#### *Deleting a Position-Report Call*

##### 1 Select **NAV INFO** > **DSC List**.

##### 2 Select a position-report call.

##### 3 Select **Review** > **Clear Report**.

#### *Viewing Vessel Trails on the Chart*

You can view trails for all tracked vessels on some chart views. By default, a black line indicates the path of the vessel, a black dot indicates each previously reported position of a tracked vessel, and a blue flag indicates the last reported position of the vessel.

##### 1 From a chart or 3D chart view, select **MENU** > **Chart Setup** > **Other Vessels** > **DSC** > **Display Setup**.

##### 2 Select the number of hours to show tracked vessels on the chart.

For example, if you select 4 Hours, all trail points that are less than four hours old appear for all tracked vessels.

#### **Individual Routine Calls**

When you connect the AQUAMAP to a Garmin VHF radio, you can use the AQUAMAP interface to set up an individual routine call.

When setting up an individual routine call from your AQUAMAP, you can select the DSC channel on which you want to communicate. The radio transmits this request with your call.

#### *Selecting a DSC Channel*

**NOTE:** The selection of a DSC channel is limited to those channels that are available in all frequency bands. The default channel is 72. If you select a different channel, the AQUAMAP uses that channel for subsequent calls until you call using another channel.

##### 1 Select **NAV INFO** > **DSC List**.

##### 2 Select a vessel or a station to call.

##### 3 Select **Review** > **Call with Radio** > **Channel**.

##### 4 Select an available channel.

#### *Making an Individual Routine Call*

**NOTE:** When initiating a call from the AQUAMAP, if the radio does not have an MMSI number programmed, the radio will not receive call information.

##### 1 Select **NAV INFO** > **DSC List**.

##### 2 Select a vessel or a station to call.

##### 3 Select **Review** > **Call with Radio**.

##### 4 If necessary, select **Channel**, and select a new channel.

##### 5 Select **Send**.

The AQUAMAP sends information about the call to the radio.

##### 6 On your Garmin VHF radio, select **Call**.

## Making an Individual Routine Call to an AIS Target

- 1 From a chart or 3D chart view, select an AIS target.
- 2 Select **AIS Vessel > Call with Radio**.
- 3 If necessary, select **Channel**, and select a new channel.
- 4 Select **Send**.

The AQUAMAP sends information about the call to the radio.

- 5 On your Garmin VHF radio, select **Call**.

## Warning Manager

### Viewing Messages

- 1 Select **NAV INFO > Warning Manager**.
- 2 Select a message.
- 3 Select **Review**.

### Sorting and Filtering Messages

- 1 Select **NAV INFO > Warning Manager > Sort/Filter**.
- 2 Select an option to sort or filter the message list.

### Saving Messages to a Memory Card

- 1 Insert a memory card into the card slot.
- 2 Select **NAV INFO > Warning Manager > Save to Card**.

### Clearing all of the Messages

Select **NAV INFO > Warning Manager > Clear Warning Manager**.

## Gauges and Graphs

The gauges and graphs provide various information about the engine and environment. To view the information, a compatible transducer or sensor must be connected to the network.

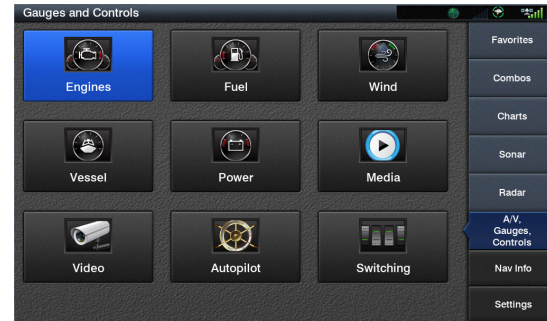

### Viewing the Gauges

- 1 Select **A/V, Gauges, Controls**.
- 2 Select a gauge.
- 3 Select ◀ or ▶ to view a different gauge page.

### Changing the Data Shown in a Gauge

- 1 From a gauges screen, hold a gauge.
- 2 Select **Replace Data**.
- 3 Select a data type.
- 4 Select the data to display.

### Customizing the Gauges

You can change the layout of the gauge pages, how the gauges pages are displayed, and the data in each gauge.

- 1 From an applicable gauges screen, select **MENU > Edit Gauge Pages**.
- 2 Select an option:
  - To change the data shown in a gauge, select the gauge.
  - To change the layout of the gauges on the page, select **Change Layout**.
  - To add a page to this set of gauge pages, select **Add Page**.
  - To remove a page from this set of gauge pages, select **Remove Page**.
  - To change the order of this page in the set of gauge pages, select **Move Page Left** or **Move Page Right**.
  - To restore this page to the original view, select **Restore Default View**.

### Customizing Engine Gauge and Fuel Gauge Limits

You can configure the upper and lower limits and the range of desired standard operation of a gauge.

**NOTE:** Not all options are available for all gauges.

- 1 From an applicable gauges screen, select **MENU > Set Gauge Limits**.
- 2 Select a gauge to customize.
- 3 Select an option:
  - To set the minimum value of the standard operating range, select **Rated Min.**
  - To set the maximum value of the standard operating range, select **Rated Max.**
  - To set the lower limit of the gauge lower than the rated minimum, select **Scale Min.**
  - To set the upper limit of the gauge higher than the rated maximum, select **Scale Max.**
- 4 Select the limit value.
- 5 Repeat steps 2 to 4 to set additional gauge limits.

## Viewing Engine and Fuel Gauges

Before you can view engine and fuel gauges, you must be connected to a NMEA 2000 network capable of sensing engine and fuel data. See the installation instructions for details.

Select **A/V, Gauges, Controls > Engines**.



### Selecting the Number of Engines Shown in Gauges

You can show information for up to four engines.

- 1 From the engine gauges screen, select **MENU > Installation > Engine Selection > Num. Engines**.
- 2 Select an option:
  - Select the number of engines.
  - Select **Auto Configure** to automatically detect the number of engines.

### Customizing the Engines Shown in Gauges

Before you can customize how the engines are shown in the gauges, you must manually select the number of engines.

- 1 From the engine gauges screen, select **MENU > Installation > Engine Selection > Edit Engines**.

- 2 Select **First Engine**.
- 3 Select the engine to display in the first gauge.
- 4 Repeat for the remaining engine bars.

## Enabling Status Alarms for Engine Gauges

You can enable the AQUAMAP to display engine status alarms.

From the engine gauges screen, select **MENU > Installation > Status Alarms > On**.

When an engine alarm is triggered, a gauge status alarm message appears and the gauge may become red depending on the type of alarm.

## Enabling Some Engine Gauge Status Alarms

- 1 From the engine gauges screen, select **MENU > Installation > Status Alarms > Custom**.
- 2 Select one or more engine gauge alarms to turn on or off.

## Setting the Fuel Alarm

Before you can set a fuel level alarm, a compatible fuel flow sensor must be connected to the AQUAMAP.

You can set an alarm to sound when the total amount of remaining onboard fuel reaches the level you specify.

- 1 Select **Settings > Alarms > Fuel > Total Fuel Onboard > On**.
- 2 Enter the remaining amount of fuel that triggers the alarm, and select **Done**.

## Setting the Fuel Capacity of the Vessel

- 1 Select **Settings > My Vessel > Fuel Capacity**.
- 2 Enter the combined total capacity of the fuel tanks.

## Synchronizing the Fuel Data with the Actual Vessel Fuel

You can synchronize the fuel levels in the AQUAMAP with the actual fuel in the vessel when you add fuel to your vessel.

- 1 Select **A/V, Gauges, Controls > Engines > MENU**.
- 2 Select an option:
  - After you have filled up all the fuel tanks on the vessel, select **Fill Up All Tanks**. The fuel level is reset to maximum capacity.
  - After you have added less than a full tank of fuel, select **Add Fuel to Boat**, and enter the amount added.
  - To specify the total fuel in the vessel tanks, select **Set Total Fuel Onboard**, and enter the total amount of fuel in the tanks.
  - To set the odometer reading to zero, select **Reset Odometer**.

## Viewing the Wind Gauges

Before you can view wind information, you must have a wind sensor connected to the AQUAMAP.

Select **A/V, Gauges, Controls > Wind**.

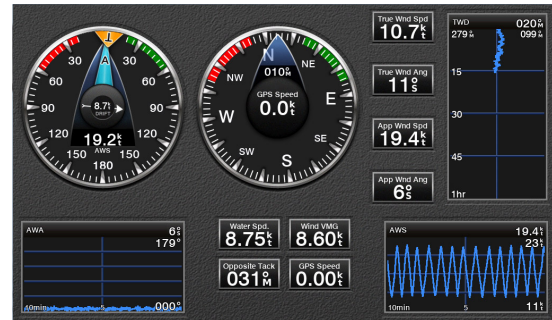

## Configuring the Sailing Wind Gauge

You can configure the sailing wind gauge to show true or apparent wind speed and angle.

- 1 From the wind gauge, select **MENU > Sailing Wind Gauge**.
- 2 Select an option:
  - To show true or apparent wind angle, select **Needle**, and select an option.
  - To show true or apparent wind speed, select **Wind Speed**, and select an option.

## Configuring the Speed Source

You can specify whether the vessel speed data displayed on the gauge and used for wind calculations is based on water speed or GPS speed.

- 1 From the wind gauge, select **MENU > Compass Gauge > Speed Display**.
- 2 Select an option:
  - To calculate the vessel speed based on data from the water-speed sensor, select **Water Speed**.
  - To calculate the vessel speed based on GPS data, select **GPS Speed**.

## Configuring the Heading Source of the Wind Gauge

You can specify the source of the heading displayed on the wind gauge. Magnetic heading is the heading data received from a heading sensor, and GPS heading is calculated by your AQUAMAP GPS (course over ground).

- 1 From the wind gauge, select **MENU > Compass Gauge > Heading Source**.
- 2 Select **GPS Hdg.** or **Magnetic**.

**NOTE:** When moving at low speeds or when stationary, the magnetic compass source is more accurate than the GPS source.

## Customizing the Close-Hauled Wind Gauge

You can specify the range of the close-hauled wind gauge for both the upwind scale and the downwind scale.

- 1 From the wind gauge, select **MENU > Compass Gauge > Gauge Type > Close Hauled Gauge**.
- 2 Select an option:
  - To set the maximum and minimum values that appear when the upwind close-hauled wind gauge appears, select **Change Upwind Scale**, and set the angles.
  - To set the maximum and minimum values that appear when the downwind close-hauled wind gauge appears, select **Change Downwind Scale**, and set the angles.
  - To view true or apparent wind, select **Wind**, and select an option.

## Viewing Trip Gauges

Trip gauges show information for odometer, speed, time, and fuel for your present trip.

Select **NAV INFO > Trip & Graphs > Trip**.

## Resetting Trip Gauges

- 1 Select **NAV INFO > Trip & Graphs > Trip**.
- 2 Select an option:
  - To set all the readings for the present trip to zero, select **Reset Trip**.
  - To set the maximum speed reading to zero, select **Reset Maximum Speed**.
  - To set the odometer reading to zero, select **Reset Odometer**.
  - To set all the readings to zero, select **Reset All**.

## Viewing Graphs

Before you can view graphs of various environmental changes, such as temperature, depth, and wind, you must have an appropriate transducer or sensor connected to the network.

Select **NAV INFO > Trip & Graphs > Graphs**.

### Setting the Graph Range and Time Scales

You can indicate the amount of time and the range of depth that appear in the depth and water temperature graphs.

- 1 From a graph, select **Graph Setup**.
- 2 Select an option:
  - To set a time-elapsed scale, select **Duration**. The default setting is 10 minutes. Increasing the time- elapsed scale allows you to view variations over a longer period of time. Decreasing the time-elapsed scale allows you to view more detail over a shorter period of time.
  - To set the graph scale, select **Scale**. Increasing the scale allows you to view more variation in readings. Decreasing the scale allows you to view more detail in the variation.
  - To set the graph scale to the default scale, select **Reset Scale**.

### Setting Weather Alarm

You can set a weather alarm to warn you when there is an abrupt change in atmospheric pressure.

- 1 From the Atm. Pressure graph, select **Graph Setup**.
- 2 Select **Weather Alarm > On**.
- 3 Select **Monitor Range**, and select a range to monitor.

## Battery Management

You can view the battery and other power sources, and the devices that use those sources.

Batteries are listed along the top of the screen. Other sources of power, such as solar, alternator, converter, and wind generator, are listed along the left side. The items along the right side of the screen are devices that use the batteries and other power sources.

### Setting Up the Battery Management Page

- 1 Select **A/V, Gauges, Controls > Battery Management > MENU > Edit Devices**.
- 2 Select an item.
- 3 Select **Device**, and select an item from the list.
- 4 If necessary, select **Name**, enter a name for this device, and select **Done**.
- 5 If necessary, select **Change Icon**, select a new symbol, and select **Done**.
- 6 Repeat steps 2 through 5 for each device.

# Media Player

**NOTE:** The media player feature is not compatible with all AQUAMAP models.

**NOTE:** Not all features are available on all connected media players.

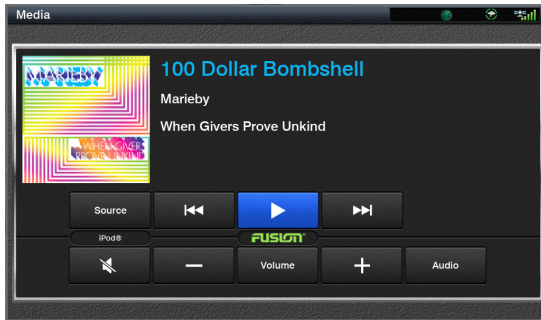

If you have a compatible stereo connected to the NMEA 2000 network, you can control the stereo using the AQUAMAP. The AQUAMAP should automatically detect the media player when it is first connected.

You can play media from sources connected to the media player and sources connected to the NMEA 2000 network.

## Opening the Media Player

Before you can open the media player, you must connect a compatible device to the AQUAMAP.

Select **A/V, Gauges, Controls > Media**.

### Buttons

**NOTE:** Not all devices have these icons.

Button	Description
	Press to select a source, such as a connected iPod or AM radio.
	Press to skip to the previous track or station.
	Press to play.
	Press to pause.
	Press to skip to the next track or station.
	Press to mute.
	Press to unmute.
	Press to decrease the volume.
	Press to open the volume menu.
	Press to increase the volume.
	Press to open the audio menu.

## Selecting the Media Source

When you have multiple media devices connected on a network, such as the NMEA 2000 network, you can select the media source you want to control from your AQUAMAP.

**NOTE:** You can play media only from sources that are connected to the device.

**NOTE:** Not all features are available on all media sources.

- 1 From the media screen, select **Source**.

**NOTE:** The source menu appears only for devices that support multiple media sources.

- 2 Select a source.

## Playing Music

### Browsing for Music

- 1 From the media screen, select **Browse** or **MENU > Browse**.
- 2 Press **SELECT** or select an option.

### Enabling Alphabetical Search

You can enable the alphabetical search feature to find a song or album in a large list.

From the media screen, select **MENU > Installation > Alpha Search**.

### Setting a Song to Repeat

- 1 While playing a song, select **MENU > Media Menu > Repeat**.
- 2 If necessary, select **Single**.

### Setting All Songs to Repeat

From the media screen, select **MENU > Media Menu > Repeat > All**.

### Setting Songs to Shuffle

- 1 From the media screen, select **MENU > Media Menu > Shuffle**.
- 2 If necessary, select an option.

## Adjusting the Volume

### Enabling and Disabling Zones

If you have wired your vessel's speakers into zones, you can enable needed zones and disable unused zones.

- 1 From the media screen, select **MENU > Media Menu > Audio Levels > Enable/Disable Zones**.

- 2 Select a zone.

### Muting the Media Volume

- 1 From the media screen, select .
- 2 If necessary, press **SELECT**.

## VHF Radio

### Scanning VHF Channels

Before you can scan VHF channels, you must set the source to VHF.

You can monitor VHF channels saved as presets for activity and automatically switch to an active channel.

From the VHF media screen, select **Scan**.

### Adjusting the VHF Squelch

**NOTE:** Your media player must support VHF radio to use this feature.

- 1 From the VHF source page, select **MENU > Media Menu > Squelch**.
- 2 Use the slider bar to adjust the VHF squelch.

## Radio

To listen to AM or FM radio, you must have a suitable marine AM/FM antenna properly connected to the stereo and be within range of a broadcasting station. For instructions on connecting an AM/FM antenna, see the stereo installation instructions.

To listen to SiriusXM® radio, you must have the appropriate equipment and subscriptions. For instructions on connecting a SiriusXM Connect Vehicle Tuner, see the stereo installation instructions.

To listen to DAB stations, you must have the appropriate equipment. For

instructions on connecting a DAB adapter and antenna, see the installation instructions provided with your adapter and antenna.

### Setting the Tuner Region

- 1 From the media screen, select **MENU > 8xxx > Installation > Tuner Region**.
- 2 Select an option.

### Changing the Radio Station

- 1 From the media screen, select an applicable source, such as **FM**.
- 2 Select **◀◀** or **▶▶** to tune to a station.

### Changing the Tuning Mode

You can change how you select a station for some media types, such as FM or AM radio.

**NOTE:** Not all tuning modes are available for all media sources.

- 1 From the media screen, select **MENU > Media Menu > Tuning Mode**.
- 2 Select an option.
- 3 If necessary, press **SELECT**.

### Presets

You can save your favorite AM stations and FM stations as presets for easy access.

You can save your favorite SiriusXM channels if you are connected to an optional SiriusXM tuner and antenna.

#### *Saving a Station as a Preset*

- 1 From an applicable media screen, tune to the station to save as a preset.
- 2 Select **Presets > Add Current Channel**.

#### *Selecting a Preset*

- 1 From an applicable media screen, select **Presets**.
- 2 Select a preset from the list.
- 3 Select **Tune to Channel**.

#### *Removing a Preset*

- 1 From an applicable media screen, select **Presets**.
- 2 Select a preset from the list.
- 3 Select **Remove Current Channel**.

## DAB Playback

When you connect a compatible Digital Audio Broadcasting (DAB) module and antenna, such as the FUSION® MS- DAB100A to a compatible stereo, you can tune in to and play DAB stations

To use the DAB source, you must be in a region in which DAB is available, and select the tuner region.

### Setting the DAB Tuner Region

You must select the region you are in to receive DAB stations properly.

- 1 From the media screen, select **MENU > Installation > Tuner Region**.
- 2 Select the region you are in.

### Scanning for DAB Stations

Before you can scan for DAB stations, you must connect a compatible DAB module and antenna (not included) to the stereo. Because DAB signals are broadcast in select countries only, you must also set the tuner region to a location where DAB signals are broadcast.

- 1 Select the **DAB** source.
- 2 Select **Scan** to scan for available DAB stations.

When scanning is complete, the first available station in the first ensemble found begins playing.

**NOTE:** After the first scan is complete, you can select Scan again to re-scan for DAB stations. When the re-scan is complete, the system starts playing the first station in the ensemble you were listening to when you started the re-scan.

## Changing DAB Stations

- 1 Select the **DAB** source.
- 2 If necessary, select **Scan** to scan for local DAB stations.
- 3 Select **◀◀** or **▶▶** to change the station.

When you reach the end of the current ensemble, the stereo automatically changes to the first available station in the next ensemble.

### *Selecting a DAB Station from a List*

- 1 From the DAB media screen, select **Browse > Stations**.
- 2 Select a station from the list.

### *Selecting a DAB Station from a Category*

- 1 From the DAB media screen, select **Browse > Categories**.
- 2 Select a category from the list.
- 3 Select a station from the list.

## DAB Presets

You can save your favorite DAB stations as presets for easy access.

You can save up to 15 DAB-station presets.

### *Saving a DAB Station as a Preset*

- 1 From the DAB media screen, select the station to save as a preset.
- 2 Select **Browse > Presets > Save Current**.

### *Selecting a DAB Preset from a List*

- 1 From the DAB media screen, select **Browse > Presets > View Presets**.
- 2 Select a preset from the list.

### *Removing DAB Presets*

- 1 From the DAB media screen, select **Browse > Presets**.
- 2 Select an option:
  - To remove one preset, select **Remove Preset**, and select the preset.
  - To remove all presets, select **Remove All Presets**.

## Setting the Device Name

- 1 From the media screen, select **MENU > Installation > Set Device Name**.
- 2 Enter a device name.
- 3 Press **SELECT** or select **Done**.

## Updating the Media Player Software

You can update the software on compatible connected stereos and accessories.

- 1 Go to [www.fusionentertainment.com/marine](http://www.fusionentertainment.com/marine), and download the software update onto a USB flash drive.

Software updates and instructions are available on your device product page.

- 2 Insert the USB flash drive into the USB port of the stereo.
- 3 On the AQUAMAP media screen, select **MENU > Installation > Update Software**.
- 4 Select the item to update.

## Viewing Video

Before you can view video, you must connect to a compatible source.

Compatible devices include video devices connected to the ports on the AQUAMAP or to the Garmin Marine Network, as well as supported network (IP-based) video cameras, encoders, and thermal cameras.



Select **A/V, Gauges, Controls > Video**.

### Selecting a Video Source

- 1 From the video screen, select **MENU > Source**.
- 2 Select the source of the video feed.

### Alternating Among Multiple Video Sources

If you have two or more video sources, you can alternate between them using a specific time interval.

- 1 From the video screen, select **MENU > Source > Alternate**.
- 2 Select **Time**, and select the amount of time each video appears.
- 3 Select **Source**, and select the video sources to add to the alternating sequence.

## Networked Video Devices

### NOTICE

A Garmin Power over Ethernet (PoE) Isolation Coupler (P/N 010-10580-10) must be used when connecting a PoE device, such as a FLIR® camera, to a Garmin Marine Network. Connecting a PoE device directly to a Garmin Marine Network AQUAMAP damages the Garmin AQUAMAP and may damage the PoE device.

Before you can view and control video devices such as IP cameras, encoders, and thermal cameras using your AQUAMAP, you must have a compatible video device connected to your AQUAMAP, and you must have a marine network cable Power over Ethernet (PoE) isolation coupler. Go to [Garmin.com](http://Garmin.com) for a list of compatible devices or to purchase a PoE Isolation Coupler.

You can connect multiple supported video cameras and up to two video encoders to the Garmin Marine Network. You can select and view up to four video sources at once.

AQUAMAPs with multiple composite built-in video inputs can display a single built-in video input only. When the cameras are connected, the network detects them automatically and displays them in the source list.

### Using Video Presets on Networked Video Cameras

You can save, name, and activate video presents for each networked video source.

#### Saving Video Presets on a Networked Video Camera

- 1 From a video screen, touch the screen. The video controls appear on the screen.
- 2 Hold a video preset button.  
A green light indicates the setting is stored.

### **Naming Video Presets on a Networked Video Camera**

- 1 From a video screen, select **MENU > Video Setup > Name**.
- 2 Enter preset name.

### **Activating Video Presets on a Networked Video Camera**

You can quickly return networked cameras to preset values.

- 1 From a video screen, touch the screen. The video controls appear on the screen.
- 2 Select a video preset.

The camera restores the video settings saved for that preset.

**TIP:** You can also save and activate presets using the video menu.

## **Camera Settings**

Some cameras provide additional options to control the camera view.

**NOTE:** Not all options are available on all camera models and AQUAMAP models. Refer to the camera manual for a list of available features. You may need to update the camera software to use this feature.

From the infrared video screen, select **MENU**.

**IR/Visible:** Displays an infrared or visible camera image.

**Scan:** Surveys the surrounding area.

**Freeze:** Pauses the camera image.

**Change Colors:** Selects the color scheme of the infrared image.

**Change Scene:** Selects the infrared image mode, such as day, night, MOB, or docking.

**Video Setup:** Opens more video options.

## **Video Settings**

Some cameras provide additional setup options.

**NOTE:** Not all options are available on all camera models and AQUAMAP

models. You may need to update the camera software to use this feature.

From the video screen, select **MENU > Video Setup**.

**Set Input:** Associates the camera with a video source.

**Mirror:** Reverses the image like a rearview mirror.

**Standby:** Places the camera in standby mode to conserve power and protect the lens when not in use.

**Home Position:** Sets the home position of the camera.

**Scan Speed:** Sets how quickly the camera moves during a scan.

**Scan Width:** Sets the width of the image captured by the camera during a scan.

**Name:** Allows you to enter a new name for this camera.

**FLIR™ Menu:** Provides access to the settings for the camera.

## **Associating the Camera to a Video Source**

You may need to associate the camera with a video source.

- 1 From the video screen, select **MENU > Source**.
- 2 Select the camera.
- 3 Select **Video Setup > Set Input**.
- 4 Select the video input.

## **Video Camera Movement Control**

### **NOTICE**

Do not aim the camera at the sun or extremely bright objects. Damage to the lens may occur.

Always use the AQUAMAP controls or buttons to pan and tilt the camera. Do not manually move the camera unit. Manually moving the camera may damage the camera.

**NOTE:** This feature is available only when a compatible camera is connected.

You may need to update the camera software to use this feature.

You can control the movements of the connected video cameras that support panning, tilting, and zooming.

### **Controlling Video Cameras Using On-Screen Controls**

On-screen controls allow you to control pan-tilt-zoom (PTZ) cameras. Refer to the camera manual for a list of available features.

From a video screen, select an option:

- To zoom in and out, turn the knob.
- To pan or tilt the camera, use the arrow keys.

### **Controlling a Video Camera Using Gestures**

When a networked video camera supports gesture responses, you can control pan-tilt-zoom cameras using gestures directly on the AQUAMAP screen. Check your camera user manual for a list of available features.

**TIP:** Using gestures allows video control without displaying the video controls.

- 1 From a video screen, touch the screen.
- 2 Select an option:
  - To zoom in and out with the camera, use pinch and zoom gestures.
  - To pan or tilt the camera, swipe the screen in the desired direction.

## **Creating a Combination with Video Functions**

You can include up to four video functions in a custom combination screen.

If your device has multiple built-in video connections, you can use one built-in source for one function within each combination.

**NOTE:** The video source displays all connected, supported video devices. You can select Show All to see a list of all possible video inputs or video encoder channels that are not connected to a video input source.

- 1 Select **Combos > MENU > Add Combo > Layout**.

- 2 Select a layout.
- 3 Select a panel, select **Video > Show All**, and select a video source.
- 4 Repeat for all video functions in the combination screen.
- 5 If necessary, customize the combination screen.

## **Configuring the Video Appearance**

**NOTE:** Not all options are available on all camera models and AQUAMAP models.

- 1 From the video screen, select **MENU > Video Setup**.
- 2 Select an option:
  - To show the video using a stretched aspect ratio, select **Aspect > Stretch**. The video cannot be stretched beyond the dimensions provided by the connected video device, and it may not fill the entire screen.
  - To show the video using a standard aspect ratio, select **Aspect > Standard**.

# Autopilot

## ⚠️ WARNING

You can use the autopilot feature only at a station installed next to a helm, throttle, and helm control device.

You are responsible for the safe and prudent operation of your vessel. The autopilot is a tool that enhances your capability to operate your boat. It does not relieve you of the responsibility of safely operating your boat. Avoid navigational hazards and never leave the helm unattended.

Always be prepared to promptly regain manual control of your boat.

Learn to operate the autopilot on calm and hazard-free open water.

Use caution when operating the autopilot near hazards in the water, such as docks, pilings, and other boats.

The autopilot system continuously adjusts the steering of your boat to maintain a constant heading (heading hold). The system also allows manual steering and several modes of automatic-steering functions and patterns.

When the AQUAMAP is connected to a compatible Garmin autopilot system, you can engage and control the autopilot from the AQUAMAP.

For information about compatible Garmin autopilot systems, go to [Garmin.com](http://Garmin.com).

## Opening the Autopilot Screen

Before you can open the autopilot screen, you must have a compatible Garmin autopilot installed and configured.

Select **A/V, Gauges, Controls > Autopilot**.

## Engaging the Autopilot

When you engage the autopilot, the autopilot takes control of the helm and steers the boat to maintain your heading.

- 1 From the autopilot screen, select **MENU**.
- 2 Select an option:
  - To steer the boat in a circular pattern, select **Engage Circle**. Your intended heading, direction, and circle time shows in the center of the autopilot screen.
  - To maintain a heading, select **Engage Heading Hold**. Your intended heading shows in the center of the autopilot screen.



## Adjusting the Heading with the AQUAMAP in Step Steering Mode

- Select **<1°** or **1°>** to initiate a single 1° turn.
- Select **<<10°** or **10°>>** to initiate a single 10° turn.
- Hold **<1°** or **1°>** to initiate a rate-controlled turn. The boat continues to turn until you let go of the key.
- Hold **<<10°** or **10°>>** to initiate a sequence of 10° turns.

## Autopilot Bar



①	Actual heading
②	Intended heading (heading the autopilot is steering toward)
③	Actual heading (when in standby mode) Intended heading (when engaged)

### Adjusting the Step Steering Increment

- 1 From the autopilot screen, select **MENU > Autopilot Setup > Step Turn Size**.
- 2 Select an increment.

### Setting the Power Saver

You can adjust the level of rudder activity.

- 1 From the autopilot screen, select **MENU > Autopilot Setup > Power Mode Setup > Power Saver**.
- 2 Select a percentage.

Selecting a higher percentage reduces rudder activity and heading performance. The higher the percentage, the more the course deviates before the autopilot corrects it.

**TIP:** In choppy conditions at low speeds, increasing the Power Saver percentage reduces rudder activity.

### Enabling Shadow Drive™

**NOTE:** The Shadow Drive feature is available only on hydraulic steering systems.

From the autopilot screen, select **MENU > Autopilot Setup > Shadow Drive > Enabled**.

### Adjusting the Heading with the Helm

With the autopilot engaged, manually steer the boat. The autopilot activates Shadow Drive mode.

When you release the helm and manually maintain a specific heading for a few seconds, the autopilot resumes a heading hold at the new heading.

## Steering Patterns

### ⚠ WARNING

You are responsible for the safe operation of your boat. Do not begin a pattern until you are certain that the water is clear of obstacles.

The autopilot can steer the boat in preset patterns for fishing, and it can also perform other specialty maneuvers such as U-turns and Williamson turns.

### Following the U-Turn Pattern

You can use the u-turn pattern to turn the boat around 180 degrees and maintain the new heading.

- 1 From the autopilot screen, select **MENU > Pattern Steering > U-Turn**.
- 2 Select **Engage Port** or **Engage Starboard**.

### Setting Up and Following the Circles Pattern

You can use the circles pattern to steer the boat in a continuous circle, in a specified direction, and at a specified time interval.

- 1 From the autopilot screen, select **MENU > Pattern Steering > Circles**.
- 2 If necessary, select **Time**, and select a time for the autopilot to steer one complete circle.
- 3 Select **Engage Port** or **Engage Starboard**.

## Setting Up and Following the Zigzag Pattern

You can use the zigzag pattern to steer the boat from port to starboard and back, over a specified time and angle, across your present heading.

- 1 From the autopilot screen, select **MENU > Pattern Steering > Zigzag**.
- 2 If necessary, select **Amplitude**, and select a degree.
- 3 If necessary, select **Period**, and select a length of time.
- 4 Select **Engage Zigzag**.

## Following the Williamson Turn Pattern

You can use the Williamson turn pattern to steer the boat around with the intent of running alongside the location where the Williamson turn pattern was initiated. The Williamson turn pattern can be used in man-overboard situations.

- 1 From the autopilot screen, select **MENU > Pattern Steering > Williamson Turn**.
- 2 Select **Engage Port** or **Engage Starboard**.

## Cancelling a Steering Pattern

- Physically steer the boat.  
**NOTE:** Shadow Drive must be enabled to cancel a steering pattern by physically steering the boat.
- Select ◀ or ▶ to cancel a pattern using step steering mode.
- Select **Standby**.





## Controlling the VIRB® Action Camera with the AQUAMAP

Before you can control a VIRB action camera with the AQUAMAP, you must connect the devices using a wireless connection.

You can connect up to five VIRB action cameras to the AQUAMAP.

After you connect the VIRB action camera with the AQUAMAP, a new option is added to **A/V, Gauges, Controls**. You can start and stop recording on the VIRB action camera using the AQUAMAP.

**NOTE:** The VIRB image shown on the AQUAMAP is in a lower resolution than the VIRB action camera records. To view the high-resolution video, view the video on a computer or television.

- 1 Select **A/V, Gauges, Controls > VIRB®**.
- 2 Select an option:
  - To take a still photograph, select .
  - To begin recording, select . When recording, the remaining recording memory is shown.
  - To stop recording, select  again.
  - If you have more than one VIRB action camera connected, use the arrows to select a different action camera to control.
  - To view stored videos or images, select .

## VIRB Action Camera Settings

Select **A/V, Gauges, Controls > VIRB® > MENU**.

**Name:** Allows you to enter a new name for the VIRB action camera.

**Recording:** Starts and stops recording.

**Take Photo:** Takes a still photograph.

**Sleep:** Puts the VIRB action camera into a low power mode to conserve battery power.

## VIRB Action Camera Video Setup Settings

Select **A/V, Gauges, Controls > VIRB® > MENU > Video Setup**.

**Aspect:** Sets the video aspect ratio.

**Video Mode:** Sets the video mode. For example, you can select the **Slow-Mo** option to shoot slow motion videos.

**Video Size:** Sets the size or pixel dimensions of videos.

**Video FPS:** Sets the frames per second.

**Photo Size:** Sets the size or pixel dimensions of photos.

**Field of View:** Sets the zoom level.

## Adding the VIRB Action Camera Controls to Other Screens

Before you can control a VIRB action camera with the AQUAMAP, you must connect the devices using a wireless connection.

You can add the VIRB action camera control bar to other screens. This allows you to start and stop recording from other functions in the AQUAMAP.





- 1 Open the screen to which you want to add the VIRB action camera control bar.
- 2 Select **MENU > Edit Overlays > Bottom Bar > VIRB Bar**.

When viewing a screen that has the VIRB action camera controls, you can select  to open the full screen view of the VIRB action camera.

## Controlling the VIRB Action Camera Video Playback

You can view VIRB action camera video and images using the AQUAMAP.

**NOTE:** The VIRB playback on the AQUAMAP is shown in the same quality as the live view on the AQUAMAP. To view the high-resolution video, view the video on a computer or television.

- 1 From the **VIRB®** screen, select .
- 2 Wait a few seconds for the thumbnail images to load.
- 3 Select a video or image.
- 4 Control the playback using the on-screen buttons or menu options:
  - To stop the video, select .
  - To pause the video, select .
  - To replay the video, select .
  - To play the video, select .

## Deleting a VIRB Video

You can delete a video or image from the VIRB action camera.

- 1 Open the VIRB video or image to delete.
- 2 Select **MENU > Delete File**.

## Starting a VIRB Video Slideshow

You can view a slideshow of the videos and images on the VIRB action camera.

- 1 From the **VIRB®** screen, select .
- 2 Wait a few seconds for the thumbnail images to load.
- 3 Select a video or image.
- 4 Select **MENU > Start Slideshow**.

To stop the slideshow, select **MENU > Stop Slideshow**.

## Communication with Wireless Devices

With a Garmin Marine Wi-Fi Adapter Kit, the AQUAMAPs can create a wireless network to which you can connect wireless devices.

Connecting wireless devices allows you to use Garmin apps, including BlueChart Mobile and Garmin Helm™. See [Garmin.com](http://Garmin.com) for more information.

### Using the Garmin Helm Application with the AQUAMAP

Before you can control the AQUAMAP with the Garmin Helm application, you must download and install the application, and connect the AQUAMAP to a Wi-Fi router.



- 1 Select **Settings > Communications > Wireless Devices > Helm App**.
- 2 Select an option.
- 3 Use the application to view or control the AQUAMAP.

## Device Configuration

### Turning On the AQUAMAP Automatically

You can set the AQUAMAP to turn on automatically when the power is applied. Otherwise, you must turn on the AQUAMAP by pressing .

Select **Settings > System > Auto Power Up**.

**NOTE:** When Auto Power Up is On, and the AQUAMAP is turned off using , and power is removed and reapplied within less than two minutes, you may need to press  to restart the AQUAMAP.

### System Settings

Select **Settings > System**.

**Sounds and Display:** Adjusts the display and audio settings.

**GPS:** Provides information about the GPS satellites and settings.

**System Information:** Provides information about the devices on the network and the software version.

**Station Information:** Adjusts the setup of the station.

**Auto Power Up:** Controls what turns on automatically when power is applied.

**Simulator:** Turns the simulator on or off and allows you to set the time, date, speed, and simulated location.

### Viewing System Software Information

You can view the software version, the basemap version, all supplemental map information (if applicable), the software version for an optional Garmin radar (if applicable), and the unit ID number. You may need this information to update the system software or to purchase additional map data information.

Select **Settings > System > System Information > Software Information**.

## Viewing the Event Log

The event log shows a list of system events.

Select **Settings > System > System Information > Event Log**.

## Station Settings

Select **Settings > System > Station Information**.

**Change Station:** Sets the entire station to a new set of defaults based on the location of this station. You can also select to use this display as a stand-alone, individual display, instead of grouping it with other displays to make a station.

**GRID™ Pairing:** Allows you to pair a GRID™ remote input device with this station.

**Display Order:** Sets the order of the displays, which is important when using a GRID remote input device.

**Autopilot Enabled:** Allows you to control the autopilot from this device.

**Reset Layouts:** Restores the factory default view for the layouts in this station.

**Reset Stations:** Restores the factory default layouts for all displays in the station.

## Preferences Settings

Select **Settings > Preferences**.

**Units:** Sets units of measure.

**Language:** Sets the on-screen text language.

**Navigation:** Sets navigation preferences.

**Keyboard Layout:** Arranges the keys on the on-screen keyboard.

**Screenshot Capture:** Allows the device to save images of the screen.

**User Data Sharing:** Allows you to share waypoints and routes over the Garmin Marine Network. All AQUAMAPs that share waypoints and routes

must have this setting turned on.

## Units Settings

Select **Settings > Preferences > Units**.

**System Units:** Sets the unit format for the device.

**North Reference:** Sets the direction references used in calculating heading information. True sets geographic north as the north reference. Grid sets grid north as the north reference (000°). Magnetic sets the magnetic north as the north reference.

**Variance:** Sets the magnetic declination, the angle between magnetic north and true north, for your present location.

**Position Format:** Sets the position format in which a given location reading appears. Do not change this setting unless you are using a map or chart that specifies a different position format.

**Map Datum:** Sets the coordinate system on which the map is structured. Do not change this setting unless you are using a map or chart that specifies a different map datum.

**Time:** Sets the time format, time zone, and daylight saving time.

## Navigation Settings

**NOTE:** Some settings and options require additional charts or hardware.

Select **Settings > Preferences > Navigation**.

**Route Labels:** Sets the type of labels shown with route turns on the map.

**Turn Transition:** Adjusts how the AQUAMAP transitions to the next turn or leg or the route. You can set the transition to be based on time or distance before the turn. You can increase the time or distance value to help improve the accuracy of the autopilot when navigating a route or an Auto Guidance line with many frequent turns or at higher speeds. For straighter routes or slower speeds, lowering this value can improve autopilot accuracy.

**Speed Sources:** Sets the source for the speed readings.

**Auto Guidance:** Sets the measurements for the Preferred Depth, Vertical Clearance, and Shoreline Distance, when you are using some premium maps.

**Route Start:** Selects a starting point for route navigation.

### Auto Guidance Path Configurations

#### ⚠ CAUTION

The Preferred Depth and Vertical Clearance settings influence how the AQUAMAP calculates an Auto Guidance path. If an area has an unknown water depth or an unknown obstacle height, the Auto Guidance path is not calculated in that area. If an area at the beginning or the end of an Auto Guidance path is shallower than the Preferred Depth or lower than the Vertical Clearance settings, the Auto Guidance path may not be calculated in that area, depending on the map data. On the chart, the course through those areas appears as a gray line or a magenta and gray striped line. When your boat enters one of those areas, a warning message appears.

**NOTE:** Auto Guidance is available with premium charts, in some areas.

**NOTE:** Not all settings apply to all maps.

You can set the parameters the AQUAMAP uses when calculating an Auto Guidance path.

**Preferred Depth:** Sets the minimum water depth, based on chart depth data, that your boat can safely travel over.

**NOTE:** The minimum water depth for the premium charts (made before 2016) is 3 feet. If you enter a value of less than 3 feet, the charts only use depths of 3 feet for Auto Guidance path calculations.

**Vertical Clearance:** Sets the minimum height of a bridge or obstacle, based on chart data, that your boat can safely travel under.

**Shoreline Distance:** Sets how close to the shore you want the Auto Guidance path to be placed. The Auto Guidance path may move if you

change this setting while navigating. The available values for this setting are relative, not absolute. To ensure that the Auto Guidance line is placed the appropriate distance from shore, you can assess the placement of the Auto Guidance path using one or more familiar destinations that require navigation through a narrow waterway.

### Adjusting the Distance from Shore

The Shoreline Distance setting indicates how close to the shore you want the Auto Guidance line to be placed. The Auto Guidance line may move if you change this setting while navigating. The available values for the Shoreline Distance setting are relative, not absolute. To ensure the Auto Guidance line is placed the appropriate distance from shore, you can assess the placement of the Auto Guidance line using one or more familiar destinations that require navigation through a narrow waterway.

- 1 Dock your vessel or drop the anchor.
- 2 Select **Settings > Preferences > Navigation > Auto Guidance > Shoreline Distance > Normal**.
- 3 Select a destination that you have navigated to previously.
- 4 Select **Navigate To > Auto Guidance**.
- 5 Review the placement of the Auto Guidance line, and determine whether the line safely avoids known obstacles and the turns enable efficient travel.
- 6 Select an option:
  - If the placement of the Auto Guidance line is satisfactory, select **MENU > Navigation Options > Stop Navigation**, and proceed to step 10.
  - If the Auto Guidance line is too close to known obstacles, select **Settings > Preferences > Navigation > Auto Guidance > Shoreline Distance > Far**.
  - If the turns in the Auto Guidance line are too wide, select **Settings > Preferences > Navigation > Auto Guidance > Shoreline Distance > Near**.

- 7 If you selected **Near** or **Far** in step 6, review the placement of the Auto Guidance line, and determine whether the line safely avoids known obstacles and the turns enable efficient travel.

Auto Guidance maintains a wide clearance from obstacles in open water, even if you set the Shoreline Distance setting to Near or Nearest. As a result, the AQUAMAP may not reposition the Auto Guidance line, unless the destination selected requires navigation through a narrow waterway.

- 8 Select an option:

- If the placement of the Auto Guidance line is satisfactory, select **MENU > Navigation Options > Stop Navigation**, and proceed to step 10.
- If the Auto Guidance line is too close to known obstacles, select **Settings > Preferences > Navigation > Auto Guidance > Shoreline Distance > Farthest**.
- If the turns in the Auto Guidance line are too wide, select **Settings > Preferences > Navigation > Auto Guidance > Shoreline Distance > Nearest**.

- 9 If you selected **Nearest** or **Farthest** in step 8, review the placement of the **Auto Guidance** line, and determine whether the line safely avoids known obstacles and the turns enable efficient travel.

Auto Guidance maintains a wide clearance from obstacles in open water, even if you set the Shoreline Distance setting to Near or Nearest. As a result, the AQUAMAP may not reposition the Auto Guidance line, unless the destination selected requires navigation through a narrow waterway.

- 10 Repeat steps 3 through 9 at least once more, using a different destination each time, until you are familiar with the functionality of the Shoreline Distance setting.

## Communications Settings

### NMEA 0183 Settings

Select **Settings > Communications > NMEA 0183 Setup**.

**Port Types:** Sets the communication format for each NMEA 018 port.

**Output Sentences:** Configures NMEA 0183 output sentences.

**Position Precision:** Adjusts the number of digits to the right of the decimal point for transmission of NMEA output.

**XTE Precision:** Adjusts the number of digits to the right of the decimal point for NMEA crosstalk error output.

**Waypoint IDs:** Sets the device to transmit waypoint names or numbers via NMEA 0183 while navigating. Using numbers may resolve compatibility issues with older NMEA 0183 autopilots.

**Defaults:** Restores the NMEA 0183 settings to the original factory defaults.

**Diagnostics:** Displays NMEA 0183 diagnostic information.

### *Setting the Communication Format for Each NMEA 0183 Port*

You can configure the communication format for each internal NMEA 0183 port when connecting your AQUAMAP to external NMEA 0183 devices, a computer, or other Garmin devices.

- 1 Select **Settings > Communications > NMEA 0183 Setup > Port Types**.
- 2 Select an input or output port.
- 3 Select a format:
  - To support the input or output of standard NMEA 0183 data, DSC, and sonar NMEA input support for the DPT, MTW, and VHW sentences, select **NMEA Standard**.
  - To support the input or output of standard NMEA 0183 data for most AIS receivers, select **NMEA High Speed**.
  - To support the input or output of Garmin proprietary data for interfacing with Garmin software, select **Garmin**.
- 4 Repeat steps 2–3 to configure additional input or output ports.

### *Configuring NMEA 0183 Output Sentences*

You can enable and disable NMEA 0183 output sentences.

- 1 Select **Settings > Communications > NMEA 0183 Setup > Output Sentences**.
- 2 Select an option.
- 3 Select one or more NMEA 0183 output sentences, and select **BACK**.
- 4 Repeat steps 2 and 3 to enable or disable additional output sentences.

## NMEA 2000 Settings

Select **Settings > Communications > NMEA 2000 Setup**.

**Device List:** Displays the devices connected to the network.

**Label Devices:** Changes the labels for available connected devices.

### *Naming Devices and Sensors on the Network*

You can name devices and sensors connected to the Garmin Marine Network and the NMEA 2000 network.

- 1 Select **Settings > Communications**.
- 2 Select **Marine Network** or **NMEA 2000 Setup > Device List**.
- 3 Select a device from the list on the left.
- 4 Select **Change Name**.
- 5 Enter the name, and select **Done**.

## Marine Network

The Marine Network allows you to share data from Garmin peripheral devices with the AQUAMAP quickly and easily. You can connect the AQUAMAP to the Marine Network to receive data from and share data with other devices and AQUAMAPs that are compatible with the Marine Network.

Select **Settings > Communications > Marine Network**.

## Setting Alarms

### Navigation Alarms

Select **Settings > Alarms > Navigation**.

**Arrival:** Sets an alarm to sound when you are within a specified distance or time from a turn or a destination.

**Anchor Drag:** Sets an alarm to sound when you exceed a specified drift distance while anchored.

**Off Course:** Sets an alarm to sound when you are off course by a specified distance.

### *Setting the Anchor Drag Alarm*

You can set an alarm to sound if you have moved more than an allowable distance. This is very useful when anchoring overnight.

- 1 Select **Settings > Alarms > Navigation > Anchor Drag**.
- 2 Select **Alarm** to turn on the alarm.
- 3 Select **Set Radius**, and select a distance on the chart.
- 4 Select **BACK**.

### System Alarms

**Clock:** Sets an alarm clock.

**Unit Voltage:** Sets an alarm to sound when the battery reaches a specified low voltage.

**GPS Accuracy:** Sets an alarm to sound when the GPS location accuracy falls outside the user-defined value.

### Collision Alarm

Before you can set a collision alarm, you must have a compatible AQUAMAP connected to an AIS device or radar.

The safe-zone collision alarm is used only with AIS and MARPA. MARPA

functionality works with radar. The safe zone is used for collision avoidance and can be customized.

#### 1 Select **Settings > Alarms > Collision Alarm > On.**

A message banner appears and an alarm sounds when a MARPA-tagged object or an AIS-activated vessel enters the safe-zone area around your boat. The object is also labeled as dangerous on the screen. When the alarm is off, the message banner and audible alarm are disabled, but the object is still labeled as dangerous on the screen.

#### 2 Select **Range** and select a distance for the safe-zone radius around your vessel.

#### 3 Select **Time To** and select a time at which the alarm will sound if a target is determined to intersect the safe zone.

For example, to be notified of a pending intersection 10 minutes before it will likely occur, set Time To to 10, and the alarm will sound 10 minutes before the vessel intersects the safe zone.

### Sonar Alarms

**NOTE:** Not all options are available on all transducers.

From an applicable sonar view, select **MENU > Sonar Setup > Alarms.**

You can also open the sonar alarms by selecting **Settings > Alarms > Sonar.**

**Shallow Water:** Sets an alarm to sound when the depth is less than the specified value.



**Deep Water:** Sets an alarm to sound when the depth is greater than the specified value.

**FrontVü Alarm:** Sets an alarm to sound when the depth in front of the vessel is less than the specified value, which can help you avoid running aground. This alarm is available only with Panoptix FrontVü transducers.

**Water Temp.:** Sets an alarm to sound when the transducer reports a temperature that is 2°F (1.1°C) above or below the specified temperature.

**Contour:** Sets an alarm to sound when the transducer detects a suspended target within the specified depth from the surface of the water and from the bottom.

**Fish:** Sets an alarm to sound when the device detects a suspended target.

-  sets the alarm to sound when fish of all sizes are detected.
-  sets the alarm to sound only when medium or large fish are detected.
-  sets the alarm to sound only when large fish are detected.

### Weather Alarms

Before you can set weather alarms, you must have a compatible AQUAMAP connected to a weather device, such as a GXM™ device, and have a valid weather subscription.

#### 1 Select **Settings > Alarms > Weather Alarms.**

#### 2 Turn on alarms for specific weather events.

### Fuel Alarm

Before you can set a fuel level alarm, a compatible fuel flow sensor must be connected to the AQUAMAP.

You can set an alarm to sound when the total amount of remaining onboard fuel reaches the level you specify.

#### 1 Select **Settings > Alarms > Fuel > Total Fuel Onboard > On.**

#### 2 Enter the remaining amount of fuel that triggers the alarm, and select **Done.**

### My Vessel Settings

**NOTE:** Some settings and options require additional charts or hardware.

Select **Settings > My Vessel.**

**Depth and Anchoring:** Allows you to enter information about the keel and the anchor.

**Temp. Offset:** Allows you to set an offset value to compensate for the water temperature reading from a NMEA 0183 water-temperature sensor or a temperature-capable transducer.

**Calibrate Water Speed:** Calibrates the speed-sensing transducer or sensor.

**Fuel Capacity:** Sets the combined fuel capacity of all the fuel tanks on your vessel.

**Vessel Type:** Enables some AQUAMAP features based on the boat type.

**CZone™:** Sets the digital switching circuits.

**System Profiles:** Allows you to save your system profile to a memory card and import system profile settings from a memory card. This can be helpful for charter or fleet vessels, and for sharing your setup information with a friend.

## Setting the Keel Offset

You can enter a keel offset to compensate the water depth reading for the transducer installation location. This allows you to view the depth of the water below the keel or the true depth of the water, depending on your needs.

If you want to know the water depth below the keel or the lowest point of your boat and the transducer is installed at the water line or anywhere above the end of the keel, measure the distance from the transducer location to the keel of the boat.

If you want to know the true water depth and the transducer is installed below the water line, measure the distance from the bottom of the transducer up to the water line.

**NOTE:** This option is only available when you have valid depth data.

1 Measure the distance:

- If the transducer is installed at the water line ① or anywhere above the end of the keel, measure the distance from the transducer location to the keel of the boat. Enter this value as a positive number.
- If the transducer is installed at the bottom of the keel ② and you want

to know the true depth of the water, measure the distance from the transducer to the water line. Enter this value in as a negative number.

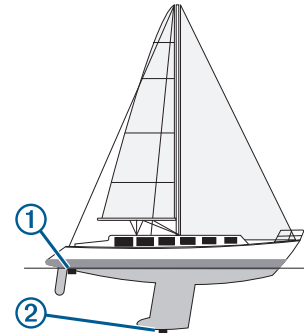

2 Select **Settings > My Vessel > Depth and Anchoring > Keel Offset**.

3 Select **+** if the transducer is installed at the water line, or select **-** if the transducer is installed at the bottom of the keel.

4 Use the arrow keys to enter the keel offset measured in step 1.

## Setting the Water Temperature Offset

Before you can set the water temperature offset, you must have a NMEA 0183 water-temperature sensor or a temperature-capable transducer to measure water temperature.

The temperature offset compensates for the temperature reading from a temperature sensor.

- 1 Measure the water temperature using the temperature sensor or temperature-capable transducer that is connected to the AQUAMAP.
- 2 Measure the water temperature using a different temperature sensor or a thermometer that is known to be accurate.
- 3 Subtract the water temperature measured in step 1 from the water temperature measured in step 2.

This is the temperature offset. Enter this value in step 5 as a positive number if the sensor connected to the AQUAMAP measures the water temperature as being colder than it actually is. Enter this value in step 5 as a negative number if the sensor connected to the AQUAMAP measures the water temperature as being warmer than it actually is.

- 4 Select **Settings > My Vessel > Temp. Offset**.
- 5 Enter the temperature offset calculated in step 3.

## Calibrating a Water Speed Device

If you have a speed-sensing transducer connected to the AQUAMAP, you can calibrate that speed-sensing device to improve the accuracy of water-speed data displayed by the AQUAMAP.

- 1 Select **Settings > My Vessel > Calibrate Water Speed**.
- 2 Follow the on-screen instructions.

If the boat is not moving fast enough or the speed sensor is not registering a speed, a message appears.

- 3 Select **OK**, and safely increase the boat speed.
- 4 If the message appears again, stop the boat, and ensure the speed-sensor wheel is not stuck.
- 5 If the wheel turns freely, check the cable connections.
- 6 If you continue to get the message, contact Garmin product support.

## Other Vessels Settings

When your compatible AQUAMAP is connected to an AIS device or VHF radio, you can set up how other vessels are displayed on the AQUAMAP.

Select **Settings > Other Vessels**.

**AIS:** Enables and disables AIS signal reception.

**DSC:** Enables and disables digital selective calling (DSC).

**Collision Alarm:** Sets the collision alarm.

**AIS-EPIRB Test:** Enables test signals from Emergency Position Indicating Radio Beacons (EPRIB).

**AIS-MOB Test:** Enables test signals from man overboard (MOB) devices.

**AIS-SART Test:** Enables test transmissions from Search and Rescue Transponders (SART).

**AIS Chinese Info.:** Enables AIS Chinese information.

## Restoring the Original AQUAMAP Factory Settings

**NOTE:** This procedure deletes all settings information you have entered.

- 1 Select **Settings > System > System Information > Factory Settings**.
- 2 Select an option.

# Appendix

## Registering Your Device

Help us better support you by completing our online registration today. Keep the original sales receipt, or a photocopy, in a safe place.

- 1 Insert a memory card into the card slot on the AQUAMAP.
- 2 Wait a few moments.  
The AQUAMAP creates a file named GarminDevice.xml in the Garmin folder on the memory card.
- 3 Remove the memory card.
- 4 Insert the memory card into your computer.
- 5 On your computer, go to [Garmin.com/express](http://Garmin.com/express).
- 6 Follow the on-screen instructions to download, install, and open the Garmin Express™ application.
- 7 Select **+** **Add a Device**.
- 8 While the application searches, select **Sign In** next to **Have marine charts or devices?** near the bottom of the screen.
- 9 Create or sign in to your Garmin account.
- 10 Follow the on-screen instructions to set up your vessel.
- 11 Select **+** **Add**.  
The Garmin Express application searches the memory card for the device information.
- 12 Select **Add Device** to register the device.  
When registration is complete, the Garmin Express application searches for additional charts and chart updates for your device.

When you add devices to the AQUAMAP network, repeat these steps to register the new devices.

## Digital Switching

Your AQUAMAP can be used to monitor or control circuits when a compatible system is connected.

For example, you can control the interior lights and navigation lights on the vessel. You can also monitor live well circuits.

To access the digital switching controls, select **NAV INFO > Circuit Control**.

For more information about purchasing and configuring a digital switching system, contact your Garmin dealer.

## Pairing the GRID Remote Input Device with the AQUAMAP

Before you can use a GRID remote input device with the AQUAMAP, you must pair the devices.

You can initiate the pairing of the devices from the AQUAMAP or from the GRID remote input device.

### Pairing the GRID Device with the AQUAMAP from the AQUAMAP

- 1 Select **Settings > System > Station Information > GRID™ Pairing > Add**.
- 2 On the GRID remote input device, press **SELECT**.

### Pairing the GRID Device with the AQUAMAP from the GRID Device

- 1 On the GRID remote input device, press **+** and **HOME** at the same time.  
A selection page opens on all of the AQUAMAPs on the Garmin Marine Network.
- 2 Rotate the wheel on the GRID remote input device to highlight **SELECT** on the AQUAMAP you want to control with the GRID remote input device.
- 3 Press **SELECT**.

## Rotating the GRID Joystick

For certain installation situations, you can rotate the orientation of the GRID joystick.

- 1 Select **Settings > Communications > Marine Network**.
- 2 Select the GRID device.

## Cleaning the Screen

### NOTICE

Cleaners containing ammonia will harm the anti-reflective coating.

The device is coated with a special anti-reflective coating which is very sensitive to waxes and abrasive cleaners.

- 1 Apply an eyeglass lens cleaner specified as safe for anti-reflective coatings to the cloth.
- 2 Gently wipe the screen with a soft, clean, lint-free cloth.

## Viewing Images on a Memory card

You can view images that are saved on a memory card. You can view .jpg, .png, and .bmp files.

- 1 Insert a memory card with image files into the card slot.
- 2 Select **NAV INFO > Image Viewer**.
- 3 Select the folder containing the images.
- 4 Wait a few seconds for the thumbnail images to load.
- 5 Select an image.
- 6 Use the arrows to scroll through the images.
- 7 If necessary, select **MENU > Start Slideshow**.

## Screenshots

You can capture a screenshot of any screen shown on your AQUAMAP as a bitmap (.bmp) file. You can transfer the screenshot to your computer. You can also view the screenshot in the image viewer.

### Capturing Screenshots

- 1 Insert a memory card into the card slot.
- 2 Select **Settings > Preferences > Screenshot Capture > On**.
- 3 Go to a screen you want to capture.
- 4 Hold **HOME** for at least six seconds.

### Copying Screenshots to a Computer

- 1 Remove the memory card from the AQUAMAP, and insert it into a card reader that is attached to a computer.
- 2 From Windows Explorer, open the Garmin\scrn folder on the memory card.
- 3 Copy a .bmp file from the card and paste it to any location on the computer.

## Troubleshooting

### My device will not acquire GPS signals

If the device is not acquiring satellite signals, there could be a few causes. If the device has moved a large distance since the last time it has acquired satellites or has been turned off for longer than a few weeks or months, the device may not be able to acquire the satellites correctly.

- Ensure the device is using the latest software. If not, update the device software.
- Make sure the device has a clear view of the sky so the antenna can receive the GPS signal. If it is mounted inside of a cabin, it should be close

to a window so it can receive the GPS signal.

## My device will not turn on or keeps turning off

Devices erratically turning off or not turning on could indicate an issue with the power supplied to the device. Check these items to attempt to troubleshoot the cause of the power issue.

- Make sure the power source is generating power.  
You can check this several ways. For example, you can check whether other devices powered by the source are functioning.
- Check the fuse in the power cable.  
The fuse should be located in a holder that is part of the red wire of the power cable. Check that the proper size fuse is installed. Refer to the label on the cable or the installation instructions for the exact fuse size needed. Check the fuse to make sure there is still a connection inside of the fuse. You can test the fuse using a multimeter. If the fuse is good, the multimeter reads 0 ohm.
- Check to make sure the device is receiving is at least 10 V, but 12 V is recommended.  
To check the voltage, measure the female power and ground sockets of the power cable for DC voltage. If the voltage is less than 10 V, the device will not turn on.
- If the device is receiving enough power but does not turn on, contact Garmin product support at [support.Garmin.com](http://support.Garmin.com).

## My device is not creating waypoints in the correct location

You can manually enter a waypoint location to transfer and share data from one device to the next. If you have manually entered a waypoint using coordinates, and the location of the point does not appear where the point should be, the map datum and position format of the device may not match the map datum and position format originally used to mark the waypoint.

Position format is the way in which the GPS receiver's position appears on

the screen. This is commonly displayed as latitude/longitude in degrees and minutes, with options for degrees, minutes and second, degrees only, or one of several grid formats.

Map datum is a math model which depicts a part of the surface of the earth. Latitude and longitude lines on a paper map are referenced to a specific map datum.

- 1 Find out which map datum and position format was used when the original waypoint was created.  
If the original waypoint was taken from a map, there should be a legend on the map that lists the map datum and position format used to create that map. Most often this is found near the map key.
- 2 Select **Settings > Preferences > Units**.
- 3 Select the correct map datum and position format settings.
- 4 Create the waypoint again.

## Specifications

### Specifications

Specification	Measurement
Display size (W x H)	AQUAMAP 10x2: 224 x 125 mm (8.8" x 4.9") AQUAMAP 12x2: 262 x 164 mm (10.3" x 6.4")
Display type	AQUAMAP 10x2: WSVGA display AQUAMAP 12x2: WXGA display
Display resolution	AQUAMAP 10x2: 1024 x 600 pixels AQUAMAP 12x2: 1280 x 800 pixels
Max. power usage at 12 Vdc	AQUAMAP 10x2: 32.4 W AQUAMAP 12x2: 43.2 W
Typical current draw at 12 Vdc	AQUAMAP 10x2: 1.9 A AQUAMAP 12x2: 2.2 A
Max. current draw at 12 Vdc	AQUAMAP 10x2: 2.7 A AQUAMAP 12x2: 3.6 A

Frequencies*	Traditional: 50/200, 77/200 kHz Single Channel CHIRP: 40 to 240 kHz Garmin ClearVü CHIRP: 260/455/800 kHz
Transmit power (RMS)**	Traditional 50/200 kHz: max 2 kW Traditional 77/200 kHz: max 500 W CHIRP high/mid/low bands: max 1 kW Garmin ClearVü CHIRP: max 500 W
Depth***	5,000 ft at 2 kW
Temperature range	From -15° to 50°C (from 5° to 122°F)
Material	Polycarbonate plastic and die-cast aluminum
Water rating****	IEC 60529 IPX7
Fuse	8 A, 125 V fast-acting
Input power	From 10 to 32 Vdc
Memory card	2 SD® card slots; 32 GB max. card size
Max. waypoints	30,000
Max. routes	200
Max. active track points	50,000 points, 50 saved tracks
Compass-safe distance	65 cm (25.5 in.)
NMEA 2000 LEN	2
NMEA 2000 draw	75 mA max.

\* Dependent upon transducer.

\*\* Dependent upon transducer rating and depth.

\*\*\* Dependent upon the transducer, water salinity, bottom type, and other water conditions.

\*\*\*\* The device withstands incidental exposure to water of up to 1 m for up to 30 min. For more information, go to [Garmin.com/waterrating](http://Garmin.com/waterrating).

## NMEA 2000 PGN Information

Type	PGN	Description
Transmit and receive	059392	ISO acknowledgment
	059904	ISO request
	060928	ISO address claim
	126208	NMEA: Command, request, and acknowledge group function
	126464	Transmit and receive PGN list group function
	126996	Product information
	127250	Vessel heading
	128259	Speed: Water referenced
	128267	Water depth
	129025	Position: Rapid update
	129026	COG and SOG: Rapid update
	129029	GNSS position data
	129540	GNSS satellites in view
	130306	Wind data
	130312	Temperature
Transmit	127258	Magnetic variance
	129283	Cross track error
	129284	Navigation data
	129285	Navigation route and waypoint info

Receive	065030	Generator average basic AC quantities (GAAC)
	126992	System time
	127488	Engine parameters: Rapid update
	127489	Engine parameters: Dynamic
	127493	Transmission parameters: Dynamic
	127504	AC output status
	127505	Fluid level
	127508	Battery status
	129038	AIS class A position report
	129039	AIS class B position report
	129040	AIS class B extended position report
	129539	GNSS DOPs
	129794	AIS class A static and voyage related data
	129809	AIS class B "CS" static data report, part A
	129810	AIS class B "CS" static data report, part B
	130310	Environmental parameters
	130311	Environmental parameters (obsolete)
	130313	Humidity
	130314	Actual pressure

## NMEA 0183 Information

Type	Sentence	Description
Transmit	GPAPB	APB: Heading or track controller (autopilot) sentence "B"
	GPBOD	BOD: Bearing (origin to destination)
	GPBWC	BWC: Bearing and distance to waypoint
	GPGGA	GGA: Global positioning system fix data
	GPGLL	GLL: Geographic position (latitude and longitude)
	GPGSA	GSA: GNSS DOP and active satellites
	GPGSV	GSV: GNSS satellites in view
	GPRMB	RMB: Recommended minimum navigation information
	GPRMC	RMC: Recommended minimum specific GNSS data
	GP RTE	RTE: Routes
	GPVTG	VTG: Course over ground and ground speed
	GPWPL	WPL: Waypoint location
	GPXTE	XTE: Cross track error
	PGRME	E: Estimated error
	PGRMM	M: Map datum
	PGRMZ	Z: Altitude
	SDDBT	DBT: Depth below transducer
	SDDPT	DPT: Depth
	SDMTW	MTW: Water temperature
	SDVHW	VHW: Water speed and heading

Receive	DPT	Depth
	DBT	Depth below transducer
	MTW	Water temperature
	VHW	Water speed and heading
	WPL	Waypoint location
	DSC	Digital selective calling information
	DSE	Expanded digital selective calling
	HDG	Heading, deviation, and variation
	HDM	Heading, magnetic
	MWD	Wind direction and speed
	MDA	Meteorological composite
	MWW	Wind speed and angle
VDM	AIS VHF data-link message	
You can purchase complete information about National Marine Electronics Association (NMEA) format and sentences from: NMEA, Seven Riggs Avenue, Severna Park, MD 21146 USA ( <a href="http://www.nmea.org">www.nmea.org</a> )		

## Software License Agreement

BY USING THE DEVICE, YOU AGREE TO BE BOUND BY THE TERMS AND CONDITIONS OF THE FOLLOWING SOFTWARE LICENSE AGREEMENT. PLEASE READ THIS AGREEMENT CAREFULLY.

Garmin Ltd. and its subsidiaries (“Garmin”) grant you a limited license to use the software embedded in this device (the “Software”) in binary executable form in the normal operation of the product. Title, ownership rights, and intellectual property rights in and to the Software remain in Garmin and/or its third-party providers.

You acknowledge that the Software is the property of Garmin and/or its third-party providers and is protected under the United States of America copyright

laws and international copyright treaties. You further acknowledge that the structure, organization, and code of the Software, for which source code is not provided, are valuable trade secrets of Garmin and/or its third-party providers and that the Software in source code form remains a valuable trade secret of Garmin and/or its third-party providers. You agree not to decompile, disassemble, modify, reverse assemble, reverse engineer, or reduce to human readable form the Software or any part thereof or create any derivative works based on the Software. You agree not to export or re-export the Software to any country in violation of the export control laws of the United States of America or the export control laws of any other applicable country.

## 物質宣言

部件名称	有毒有害物质或元素					
	铅	汞	镉	六价铬	多溴联苯	多溴二苯醚
印刷电路板组件	X	O	O	O	O	O
屏幕/背光	X	O	O	O	O	O
金属零件	X	O	O	O	O	O
电缆 电缆组件 连接器	X	O	O	O	O	O

本表格依据 SJ/T11364 的规定编制。

O: 代表此种部件的所有均质材料中所含的该种有害产 害物质均低于(GB/T26572) 规定的限量。

X: 代表此种部件所用的均质材料中, 至少有一类材料其所含的有害物质高于(GB/T26572) 规定的限量。

\* 該產品說明書應提供在環保使用期限和特殊標記 的部分詳細講解產品的擔保使用條件。



[support.Garmin.com](http://support.Garmin.com)



December 2017